

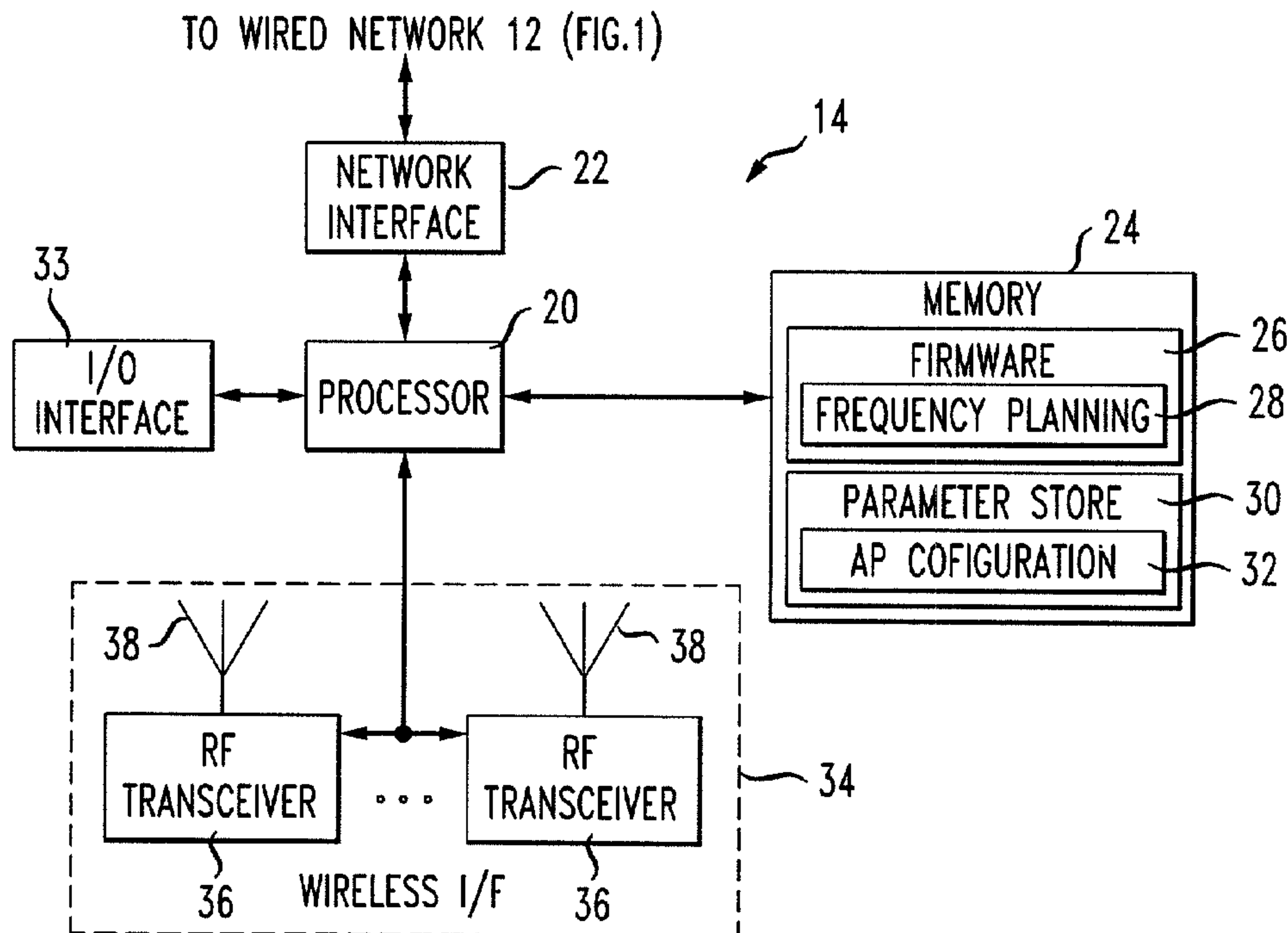

(22) Date de dépôt/Filing Date: 2002/11/07
(41) Mise à la disp. pub./Open to Public Insp.: 2003/05/08
(30) Priorité/Priority: 2001/11/08 (60/337,694) US

(51) Cl.Int.⁷/Int.Cl.⁷ H04Q 7/36, H04L 12/24
(71) Demandeur/Applicant:
AT&T CORP., US
(72) Inventeurs/Inventors:
KIM, BYOUNG-JO J., US;
LEUNG, KIN K., US
(74) Agent: KIRBY EADES GALE BAKER

(54) Titre : ASSIGNATION DE FREQUENCE POUR RESEAUX SANS FIL IEEE 802.11 A PLUSIEURS CELLULES
(54) Title: FREQUENCY ASSIGNMENT FOR MULTI-CELL IEEE 802.11 WIRELESS NETWORKS



(57) **Abrégé/Abstract:**

A frequency planning method for use in an IEEE 802.11 wireless network is described. The frequency planning method obtains traffic load information associated with access points belonging to a multi-cell wireless network and assigns channels to the access points based on the traffic load information.

FREQUENCY ASSIGNMENT FOR MULTI-CELL IEEE 802.11 WIRELESS NETWORKS

ABSTRACT

5 A frequency planning method for use in an IEEE 802.11 wireless network is described. The frequency planning method obtains traffic load information associated with access points belonging to a multi-cell wireless network and assigns channels to the access points based on the traffic load information.

FREQUENCY ASSIGNMENT FOR MULTI-CELL IEEE 802.11 WIRELESS NETWORKS

CROSS REFERENCE TO RELATED APPLICATIONS

5 This application claims the benefit of U.S. Provisional Patent Application Ser. No. 60/337,694 (Attorney Docket No. 2001-0531), filed November 8, 2001, which is incorporated herein by reference in its entirety for all purposes.

BACKGROUND

10 The invention relates to frequency planning for wireless networks.

To meet the growing demand for wireless data services, many companies have started deploying wireless local area networks (WLANs) in airports, hotels, convention centers, coffee shops and other locations in which network access by the public is desirable. Many of these WLANs support the popular IEEE standard for wireless Local Area Network (LAN) protocol, known as the IEEE 802.11 standard. The IEEE 802.11 standard includes a medium access control (MAC) layer and several physical layers, including a frequency-hopping spread spectrum (FHSS) physical layer and a direct sequence spread spectrum (DSSS) physical layer. Versions of the IEEE 802.11 standard include the IEEE 802.11a standard, which describes a physical layer based on orthogonal frequency division multiplexing (OFDM), and the IEEE 802.11b standard, which specifies a high-rate DSSS layer. Because of its maturity and low cost, IEEE 802.11b capability has been included as standard equipment in many laptop computers and hand-held devices. Thus, IEEE 802.11b products make up the bulk of the installed base of IEEE 802.11 systems. The IEEE 802.11 WLANs support data rates up to 11 Mbps, albeit over short ranges, far exceeding that to be offered by the third generation (3G) cellular wireless networks.

25 The IEEE 802.11 WLANs and 3G networks (or conventional cellular wireless networks) have major differences in their design at physical (PHY) and medium access control (MAC) layers to meet different needs. In general, the IEEE 802.11 design is much simpler than that of the 3G network because the IEEE 802.11 standard was devised to

serve a confined area (e.g., a link distance of at most several hundred meters) with stationary and slow-moving users, while the 3G specifications were developed for greater flexibility in terms of geographical coverage and mobility, even providing for users traveling at a high speed. As a result, the IEEE 802.11 network can support data rates higher than those by the 5 3G networks. In addition, the cost of IEEE 802.11 equipment is much lower than that for 3G equipment because of the simple and open design of IEEE 802.11 networks, coupled with competition among WLAN vendors.

In terms of operations, the 3G spectrum (such as the Personal Communications System (PCS) band at 1.9 GHz) is licensed and very expensive. As a 10 result, every effort has been directed toward optimizing the spectral efficiency while maintaining the quality of service in terms of coverage and data rate for a limited spectrum allocation. In contrast, the IEEE 802.11b networks operate in the unlicensed Industrial, Scientific and Medical (ISM) band at 2.4 GHz. Since the frequency band is free, there is 15 apparently no pressing need to optimize the spectral efficiency. Rather, simplicity and achieving low cost for the equipment are more important. Despite the relatively abundant spectrum (i.e., a total of 75 MHz in the 2.4GHz Band) at the ISM band, as IEEE 802.11b networks are deployed widely, they start to interfere with each other. Such interference leads to a degradation in network throughput.

Frequency planning, i.e., allocation of a limited number of frequencies, for an 20 IEEE 802.11b network is different from that for a traditional cellular network. Frequency planning techniques for cellular wireless networks are well known. In typical cellular wireless networks, such as those based on the Global System for Mobile Communications (GSM) and Enhanced Data GSM Evolution (EDGE) standards, two separate radio channels, namely the traffic and control channels, are used to carry user data and control traffic, 25 respectively. For example, terminals access the control channels to send control information via some contention mechanism. After the information is successfully received and processed by a base station (BS), the terminal is assigned with a specific traffic channel for transmitting its data traffic. Existing frequency assignment or radio-resource allocation schemes were devised mainly for such traffic channels. Such schemes seek to avoid mutual

interference among various terminals or BSs using the same frequency. In practical networks, there is no real-time coordination among BSs in the assignment of traffic channels to terminals in different cells. Thus, frequency assignment or radio-resource allocation is based on statistical averages or worst cases, e.g., 90 % chance of acceptable link quality,
5 across multiple co-channel cells. Typically, frequency planning mechanisms for traditional cellular networks tend to assign the same frequency to cells that are a sufficient distance apart.

There is no such distinction between control and traffic channels in the IEEE 802.11b network. Instead, all user data and control information (in both directions between
10 terminals and APs) are carried on the same physical channel. The access to the channel by multiple transmitters is coordinated by the MAC protocol, e.g., the well-known, Carrier Sense Multiple Access (CSMA) protocol with collision avoidance feature. Under that protocol, a transmitter can transmit only if it senses that the channel is currently idle. As a result, even if two closely located APs are allocated with the same frequency channel, much
15 of the mutual (co-channel) interference can still be avoided by the CSMA protocol, and the available bandwidth is shared implicitly between the two cells served by the two APs. In a sense, the MAC protocol provides an effective, distributed mechanism to "coordinate" the channel access among terminals and APs. In the worst case, both APs behave as if they share the same frequency. Nevertheless, the IEEE 802.11 protocol still works properly, thus
20 demonstrating the robustness of its design, at the expense of increased delay (due to backoff when sensing channel busy) and degraded network throughput.

Consequently, existing frequency allocation mechanisms that do not consider the combined effect of physical channel and MAC protocol are not directly applicable to the IEEE 802.11 networks. The MAC CSMA protocol helps to avoid much of co-channel
25 interference in large multi-cell IEEE 802.11 networks, but does so at the potential expense of network performance.

SUMMARY

The invention provides for frequency planning in wireless networks. Traffic

load information is obtained for access points belonging to a multi-cell wireless network. Channels are assigned to the access points based on the traffic load information.

Embodiments of the invention may include one or more of the following features.

5 The channels may be assigned by determining, for each access point, at least one set of interferers from among the other access points relative to the access point. The at least one set of interferers may be determined by determining, for each of the other access points, if any co-channel interference by the other access point is greater than or equal to a detection threshold and, if it is determined that the co-channel interference is greater than or
10 equal to the detection threshold, identifying the other access point as belonging to the set of interferers for the access point. The detection threshold is indicative of a busy channel according to the CSMA protocol.

 The co-channel interference may be derived from values of signal path loss between the access point and the other access point and transmission power of the other access
15 point.

 Particular implementations of the invention may provide one or more of the following advantages. The frequency planning mechanism serves as a valuable tool for frequency planning of large-scale multi-cell IEEE 802.11 WLANs by focusing on interactions among devices such as access points based on their traffic loads and radio propagation. Thus,
20 collision of signals in a frequency band that would otherwise occur among the APs are minimized or avoided while throughput of information is optimized. The frequency planning tool can be deployed in a number of different applications, e.g., as part of managed wireless LAN services for business customers or, alternatively, as part of an access point product for an automatic and adaptive frequency planning.

25 Other features and advantages of the invention will be apparent from the following detailed description and from the claims.

BRIEF DESCRIPTION OF THE DRAWINGS

FIG. 1 is block diagram of a wireless network having multiple access points

(APs).

FIG. 2 is a block diagram showing an internal architecture of an AP configured with a tool for performing a frequency assignment process.

5 FIG. 3 is an illustration of different classes of co-channel interferer APs relative to a given AP.

FIG. 4 is a flow diagram of one exemplary embodiment of the frequency assignment process (of FIG. 2).

FIG. 5 is an illustration of an exemplary frequency assignment produced by the frequency assignment process (of FIG. 4) for a wireless network with 7 cells and 21 APs.

10 FIG. 6 is an illustration of an exemplary frequency assignment produced by the frequency assignment process (of FIG. 4) for a wireless network with 37 cells and 111 APs.

DETAILED DESCRIPTION

Referring to FIG. 1, a wireless network 10 includes a wired network 12 (e.g.,
15 a Local Area Network or "LAN") having multiple wireless access points 14 coupled thereto. The network 10 further includes wireless stations or terminals 16 associated with the different APs 14 to form infrastructure basic service structures (or cells) 18. The AP 14 and terminals 16 served by that AP 14 (collectively referred to as a "cell") in a given infrastructure basic service set (BSS) 18 communicate with each other over a common
20 channel that is assigned to the AP. In the embodiment described herein, the AP 14 and terminals 16 communicate with each other according to the wireless protocol provided by the IEEE 802.11 standard. The IEEE 802.11 standard specifies the medium access control (MAC) and the physical (PHY) characteristics for WLANs. The IEEE 802.11 standard is defined in International Standard ISO/IEC 8802-111, "Information Technology-
25 Telecommunications and Information Exchange Area Networks," 1999 Edition, which is hereby incorporated by reference in its entirety. The APs 14 thus provide for communications between the terminals 16 and any devices that may be connected to the wired network 12.

Adjacent access points (APs) in IEEE 802.11 networks can be assigned with

the same channel or frequency, which is shared by those APs and their associated terminals according to the multiple access protocol (MAC), namely, the Carrier Sensing Multiple Access with Collision Avoidance (CSMA/CA) protocol. Although the CSMA/CA protocol can coordinate the bandwidth sharing of the same radio frequency in IEEE 802.11 networks, traffic load for the APs has to be considered so that there is enough link capacity for the expected traffic load.

In accordance with the present invention, therefore, the network 10 employs a frequency planning mechanism that considers the combined effects of radio propagation, the IEEE 802.11 MAC protocol and traffic load, so as to mitigate the impact of co-channel interference on the performance of an IEEE 802.11 network.

Referring to FIG. 2, an exemplary AP 14 is shown. The AP 14 includes a processor 20, coupled to the network 12 by way of a network interface 22. The network interface 22 permits the processor 20 to send and receive units of data, such as packets, over the network 12 using conventional techniques. The processor 20 is also coupled to memory 24. The memory 24 stores firmware 26 that, when executed by the processor 20, causes the access point 14 to operate as described herein. In particular, when the AP 14 is designated to serve as a "master" AP, the firmware 26 includes a frequency planning (or assignment) process 28 that allows the AP 14 to generate channel assignments for all of the APs 14 in the network 10. In an alternative embodiment, with appropriate synchronization, each AP 14, with its own copy of the frequency assignment software, could perform the process to determine channel assignment in a distributed manner. Also stored in memory 24 is a parameter store 30 which stores, among other information, AP configuration 32, including channel assignment information and possibly AP traffic load information and radio parameter data. The AP 14 can also include an I/O interface 33 to allow the AP to be connected to other peripherals.

It will be appreciated that the functionality of the AP 14 may reside in a computer system such as a PC or workstation, with a user interface for manually configuring the access point with information, e.g., channel assignment, or, in the case of the AP running the channel assignment process 28, parameter data to be used by the channel assignment

process, or can be connected to a management console for such purpose.

Alternatively, the entire channel assignment process can be installed and executed on a separate system such as a network management system. Once the network management system or AP responsible for the channel assignment has generated the assignment information, AP configuration information including the channel assignment can
5 be provided to the APs over the network, or the APs can be configured with the appropriate channel assignment manually.

The process 28 can be implemented as an automated process that is performed when an initial site "layout" is being defined. At such a stage, the process runs
10 after some pre-determined time interval during which initial loading information is collected. Preferably, it can execute whenever an access point joins or is removed from the network, or whenever AP loading conditions have changed.

The AP 14 includes a wireless interface 34 that includes one or more wireless transceivers 36. In the described embodiment, the transceivers 36 are radio frequency (RF)
15 transceivers. Typically, each transceiver 36 includes its own receiver for receiving wireless RF communications from a terminal, a transmitter for transmitting wireless RF communications to a terminal, and a microprocessor to control the transceiver. Wireless communications are received and transmitted by the transceivers 36 via respective antennas 38, which are connected to the transceiver. Each of the transceivers 36 and antennas 38 are
20 conventional in configuration and operation.

Frequency planning for IEEE 802.11 networks has two distinct characteristics. First, according to the spectrum allocation in North America, there are three overlapping channels for allocation in the IEEE 802.11b networks and eight overlapping channels for IEEE 802.11a networks. Thus, one has to adopt a tight frequency reuse
25 strategy for the 802.11 networks.

The original IEEE 802.11 specification allows for several different kinds of physical layers, including direct sequence spread spectrum (DSSS), frequency hopping spread spectrum (FHSS) and infrared (IR). In particular, the DSSS design supports data rates of 1 and 2 Mbps. Subsequently, while maintaining backward compatibility to the DSSS

802.11, the IEEE 802.11b was adopted to support data rates of 5.5 and 11 Mbps, operating in the 2.4 GHz ISM band. As a result, the IEEE 802.11b network can support 1, 2, 5.5 and 11 Mbps, depending on radio conditions. Another extension is IEEE 802.11a, which uses a different physical layer known as orthogonal frequency division multiplexing (OFDM) to support data rates ranging from 6 to 54 Mbps, operating in the 5.5 GHz band (the U-NII band).

Although the channel assignment technique of the process 28 is described with respect to IEEE 802.11b networks, it will be understood that the technique can be applied to other IEEE 802.11-based networks as well. The IEEE 802.11 MAC protocol supports the independent basic service set (IBSS), which has no connection to wired networks (i.e., an ad-hoc wireless network), as well as an infrastructure BSS, which includes an AP connecting to a wired network (as shown in FIG. 1). While the present invention also applies to the IBSS case, only the infrastructure BSS will be considered.

A brief description of the IEEE 802.11 MAC protocol follows. The IEEE 802.11 specification defines five timing intervals for the MAC protocol. Two of them are considered to be basic ones that are determined by the physical layer: the short interframe space (SIFS) and the slot time. The other three intervals are defined based on the two basic intervals: the priority interframe space (PIFS) and the distributed interframe space (DIFS), and the extended interframe space (EIFS). The SIFS is the shortest interval, followed by the slot time. The latter can be viewed as a time unit for the MAC protocol operations, although the IEEE 802.11 channel as a whole does not operate on a slotted-time basis. For IEEE 802.11b networks (i.e., with a DSSS physical layer), the SIFS and slot time are 10 μ s and 20 μ s, respectively. The PIFS is equal to SIFS plus one slot time, while the DIFS is the SIFS plus two slot times. The EIFS is much longer than the other four intervals and is used if a data frame is received in error.

The IEEE 802.11 MAC supports the Point Coordination Function (PCF) and the Distributed Coordination Function (DCF). The PCF provides contention-free access, while the DCF uses the carrier sense multiple access with collision avoidance (CSMA/CA) mechanism for contention-based access. The two modes are used alternately in time.

The DCF operates as follows. An AP (or station) with a new packet ready for transmission senses whether or not the channel is busy. If the channel is detected idle for a DIFS interval (i.e., 50 μ s for IEEE 802.11b networks), the AP starts packet transmission. Otherwise, the AP continues to monitor the channel busy or idle status. After finding the channel idle for a DIFS interval, the AP: a) starts to treat channel time in units of slot time, b) generates a random backoff interval in units of slot time, and c) continues to monitor whether the channel is busy or idle. In the last step, for each slot time where the channel remains idle, the backoff interval is decremented by one. When the interval value reaches zero, the AP starts packet transmission. During this backoff period, if the channel is sensed busy in a slot time, the decrement of the backoff interval stops (i.e., is frozen) and resumes only after the channel is detected idle continuously for the DIFS interval and the following one slot time. Again, packet transmission is started when the backoff interval reaches zero. The backoff mechanism helps avoid collision since the channel has been detected to be busy recently. Further, to avoid channel capture, an AP must wait for a backoff interval between two consecutive new packet transmissions, even if the channel is sensed idle in the DIFS interval.

The IEEE 802.11 standard requires a receiver to send an acknowledge message (ACK) for each packet that is successfully received. Furthermore, to simplify the protocol header, an ACK contains no sequence number and is used to acknowledge receipt of the immediately previous packet sent. That is, APs and stations exchange data based on a stop-and-go protocol. The sender is expected to receive the ACK within the 10 μ s SIFS interval after the packet transmission is completed. If the ACK does not arrive at the sender within a specified ACK - timeout period, or it detects transmission of a different packet on the channel, the original transmission is considered to have failed and is subject to retransmission by the backoff mechanism.

In addition to the physical channel sensing, the IEEE 802.11 MAC protocol implements a network allocation vector (NAV), whose value indicates to each station the amount of time that remains before the channel will become idle. All packets contain a duration field and the NAV is updated according to the field value in each decoded packet,

regardless of the intended recipient of the packet. The NAV is thus referred to as a virtual carrier sensing mechanism. The MAC uses the combined physical and virtual sensing to avoid collision.

The protocol described above is called the two-way handshaking. In addition,
5 the MAC also contains a four-way protocol that requires the transmitter and receiver to exchange Request-to-Send (RTS) and Clear-to-Send (CTS) messages before sending actual data, as a way to resolve the so-called hidden terminal problem.

The available number of non-overlapping channels for IEEE 802.11 WLAN systems depends on the underlying PHY layer. In North America, the ISM band at 2.4 GHz
10 is divided into eleven channels for the IEEE 802.11 network where adjacent channels partially overlap each other. Nevertheless, among these eleven channels, there are three completely non-overlapping ones, separated by 25 MHz at their center frequency. In principle, all eleven channels are available for allocation in a given IEEE 802.11 network. However, it may be that overlapping channels can cause enough interference that it is not
15 beneficial to assign overlapping channels to APs. Therefore, only the assignment of non-overlapping channels is considered. The approach to frequency planning described herein can be extended to the allocation of overlapping channels with proper weighting of the overlapped spectrum, proportional to their overlaps, however.

The frequency assignment process 28 described herein focuses on
20 transmission by the APs because the bandwidth consumption for downlink (i.e., from AP to terminal) transmission is much higher than that for uplink (i.e., from terminal to AP) transmission for typical office environment and Internet applications.

The frequency assignment process 28 takes into account the radio-path signal loss between every pair of APs in the network 10 and uses that information to define sets or
25 classes of interferers for each i -th AP (or " AP_i "). Based on the interferer classification and the expected traffic utilization (load) associated with each AP, the effective channel utilization as seen by each AP can be determined. The effective channel utilization represents the sum of the traffic load of the AP and that "induced" by its interferers because of channel sensing. In one embodiment, the problem of frequency planning is formulated as

a non-linear zero-one integer programming problem, where one of the objective functions is to minimize the effective utilization of the “bottleneck” channel (i.e., the AP with the most highly loaded channel). A heuristic algorithm is used to solve the problem.

For a network having M APs, indexed from 1 to M , and in accordance with the CSMA protocol, an AP with traffic ready for transmission determines if the assigned channel (frequency) is busy or idle. For example, if the AP detects that the received power of co-channel interference is equal to or greater than a channel-busy detection threshold α (in units of mW), which corresponds to about -80 dBm in the IEEE 802.11b standard, the channel is considered to be busy. Otherwise, it is idle.

It is possible that the channel busy status is due to a single transmitting AP or a group of multiple APs transmitting simultaneously. For efficient frequency assignment, the interferers for each AP can be classified as follows. Specifically, for each AP_i , $C_i(1)$ denotes a set of interfering APs where transmission by any one AP in the set can cause enough interference for AP_i to detect channel busy. The APs in the set $C_i(1)$ are called class-1 interferers for AP_i . Likewise, $C_i(2)$ denotes a set of pairs of two interfering APs where transmission by any pair of APs in the set can cause AP_i to sense channel busy. The APs in $C_i(2)$ are referred to herein as class-2 interferers. It can be noted that transmissions by any single AP in $C_i(2)$ are not sufficient to cause AP_i to sense channel busy. Further, the APs in any AP pair in $C_i(2)$ are not class-1 interferers to each other.

Referring to FIG. 3, an example of interferer class definition for a given AP is shown. The $C_i(1)$ and $C_i(2)$ interferers for each AP_i can be determined by measuring or estimating signal path loss between each pair of APs in the network. Letting P_j and h_{ij} denote the transmission power at AP_j and the signal path loss from AP_j to AP_i , respectively, the classification of AP_j as a $C_i(1)$ interferer requires that

$$h_{ij}P_j \geq \alpha. \quad \text{Eq. (1)}$$

where $h_{ij}P_j$ represents, for AP_i , the co-channel interference contributed by AP_j , (indicated in the figure by reference numeral 42a) and α is the power threshold to detect channel busy.

Similarly, where P_m and P_n denote the transmission power at AP_m 16b and AP_n 16c, respectively, and h_{im} and h_{in} denote the signal path loss from AP_m 16b to AP_i 16a and AP_n 16c to AP_i 16a, respectively, the pair AP_m and AP_n belongs to $C_i(2)$ if

$$5 \quad h_{im} P_m + h_{in} P_n \geq \alpha. \quad \text{Eq. (2)}$$

where $h_{im} P_m + h_{in} P_n$ represents the co-channel interference of the AP pair AP_m and AP_n (indicated in the figure by reference numeral 42b).

10 It is assumed the transmission power in Equations (1) and (2) is fixed in this disclosure. However, the channel assignment mechanism could be adapted to support dynamic power control as well.

It is possible to define class-3 or even higher classes of interferers as well. Due to the contention-oriented nature of the CSMA protocol, however, the traffic load on each channel (i.e., the probability of transmission at a given AP) cannot be too high. Thus, 15 the probability of having interferers of class-3, which require simultaneous transmission at all three interfering APs, is much smaller relative to that of the class-1 and class-2 interferers. Hence, for simplicity, only class-1 and class-2 interferers are considered by the process 28. The process 28 also takes into account AP traffic load, denoted generally by ρ .

Measurement of known RF parameters such as transmission power and signal 20 path loss can be carried out by a dedicated hardware device, such as a handheld measurement device, or a site survey software tool running on a network manager console or PC, or even on the AP device itself. Many wireless LAN equipment vendors bundle such tools with their access point hardware. Traffic load can also be measured or modeled by commercially available network management software.

25 Once measured, modeled or estimated, such parameter data (measurements or estimates, as discussed above) is stored in the memory 24 for use by the process 28.

There are a total of N (non-overlapping) channels, indexed by 1 to N , available for allocation. As pointed out above, $N=3$ for the IEEE 802.11b network for non-overlapping channels. With such a small N , it is assumed that each AP is assigned one and

only one channel. An effective channel utilization U_i is defined as the fraction of time at which the channel can be sensed busy or is used for transmission by AP_i . That is,

$$U_i = \rho_i + \sum_{k=1}^N X_{ik} \left[\sum_{j \in C_i(1)} \rho_j X_{jk} + \sum_{(m,n) \in C_i(2)} \rho_m \rho_n X_{mk} X_{nk} \right]. \quad \text{Eq. (3)}$$

where assignment indicator (or weight) X_{ij} is equal to '1' if AP_i is assigned with channel j and is equal to '0' otherwise.

Referring to Equation (3) above, the first term ρ_i is the offered traffic load for AP_i in terms of channel utilization without interference from any source. The first summation term inside the brackets in Equation (3) represents the total traffic load of all class-1 interfering APs that are assigned the same channel as AP_i . As discussed earlier, according to the CSMA protocol and because of the detection threshold α in use, AP_i senses channel busy when any one of its class-1 interferers transmits on the same channel. The last summation term in Equation (3) represents the total traffic load of all class-2 interferers. The interferer classes can be defined to include overlapping channels as well. For example, the transmission power from interferers on overlapping channels can be weighted proportionally to the spectrum overlap. The weight for non-overlapping channels is '0', and for fully overlapping co-channel cases is '1'. Partially overlapping ones are somewhere in between depending on their carrier frequency offset, filter shapes and other factors.

Channel stability is maintained (i.e., all traffic can be sent eventually) by requiring that

$$U_i < S \quad \text{Eq. (4)}$$

for all AP_i where $i = 1$ to M , and a threshold S is equal to a value of 1. The value of S can be made less than 1 to account for overhead of CSMA contention or other source of interference.

One objective function for the channel assignment is to minimize the effective utilization of the "bottleneck" AP, that is,

$$\text{minimize max } \{U_1, U_2, \dots, U_m\} \quad \text{Eq. (5)}$$

over the assignment indicator $\{X_{ij}\}$ subject to the constraints of Equation (4) for all $i = 1$ to
 5 M. Clearly, the objective function in Equation (5) is to assign channels such that the effective utilization of the most heavily loaded AP is minimized. This results in more resources available for the most heavily loaded AP, given offered traffic loads.

In one embodiment, for the channel assignment process 28 with Equation (5) as the objective function, a heuristic algorithm is utilized, as described below with reference
 10 to FIG. 4. Thus, the heuristic algorithm attempts to minimize the effective channel utilization for the bottleneck AP. The heuristic algorithm makes use of the following parameters: offered traffic load p_i and interferer sets $C_i(1)$ and $C_i(2)$ for each AP_i . Preferably, the process 28 is subject to constraints of Equation (4) for all APs.

Referring to FIG. 4, the process 28 begins (step 50) by generating a random
 15 (initial) channel assignment for each AP_i in the network (step 52). This assignment is treated as the best assignment obtained so far. The process 28 determines the effective channel utilization U_i for each AP_i based on the generated channel assignment (step 54). The process 28 identifies the AP (say, the "i-th" AP, or AP_i) with the highest or maximum effective channel utilization (step 56). This AP is referred to as the "bottleneck" AP. The
 20 maximum effective channel utilization, that is, $\max \{U_i\}$, for the assignment is denoted by V (step 58). In case of a tie, one such AP_i is chosen randomly as the "bottleneck." For the bottleneck AP_i , the process 28 identifies its current assigned channel, say channel k (step 60). For each available channel n from 1 to N with $n \neq k$ and each co-channel AP (say j) in $C_i(1)$ (i.e., those APs in the set that have been assigned with channel k), the process 28
 25 temporarily modifies the channel assignment by reassigning only AP_j with channel n , and recomputes the maximum effective channel utilization, denoted by W_{jn} , for the new assignment (step 62). After completing such testing for all such n and j , the process 28 determines the minimum, denoted by W , from among all the W_{jn} 's (step 64). The process 28 compares the values of W and V (step 66). If the process 28 determines that the value of W

is less than that of V, then the process 28 replaces V by W, records the associated new assignment as the “new” best solution (i.e., to finalize the channel change for one AP that minimizes the objective function the most)(step 70), and returns to step 54. If, at step 72, the process 28 determines that W and V are equal, then, with a pre-specified probability δ , preferably in the range $1 > \delta > 0$ (to avoid infinite looping, as discussed later), the process 28 replaces V by W, records the new assignment as the best solution (step 74) and returns to step 54. If the process 28 determines that W is greater than V, the process 28 saves the current assignment and associated V value as the best solution obtained so far (that is, the current assignment is the local suboptimal assignment) (step 76). The process 28 determines if there is another random assignment to be considered (step 78). If so, the process 28 returns to step 52 to repeat the processing for another random assignment. If no further random assignments are to be considered, the process 28 selects a final assignment as the best solution, that is, it is the channel assignment with the lowest value of V, among the local suboptimal assignments reached at step 76 (step 80). The process 28 tests the final solution to determine if constraints of Equation (4) for all APs are satisfied for the final assignment (step 82). If so, the final assignment is feasible. Otherwise, it is considered that no feasible solution exists for the network under consideration. After the feasibility is tested, the process 28 terminates (step 84).

While the process 28 as illustrated in FIG. 4 may not explicitly consider the constraints of Equation (4), minimizing the maximum U_i implicitly enhances the chance of satisfying constraints of Equation (4) for all APs.

There are several characteristics of the heuristic assignment technique that are worth further consideration. First, it can be shown that the heuristic assignment technique has a loop-free property, that is, with $1 > \delta > 0$ in step 74 (FIG. 4), the heuristic algorithm does not have infinite looping. The proof is as follows. Given that the number of AP's M and available channels N in the system are finite, steps of identifying the bottleneck AP and determining W can be completed in a finite amount of time. The only possibility that the algorithm has an infinite loop is that the steps of processing a random assignment are executed repeatedly without stop. Assume, preliminarily, that such looping can occur, that

the V value after the m -th execution (iteration) is denoted by V_m , and that $\delta=0$ in step 74. To form the infinite looping requires that $V_1 > V_2 > \dots > V_m$ with m increasing towards infinity. With both M and N being finite, there are only a finite number of all possible channel assignments. Since each new assignment finalized by step 70 has a unique
 5 maximum effective channel utilization, it is thus impossible that m goes to infinity. That is, step 76 must be reached after a finite amount of processing.

Now assume that infinite looping is possible with $1 > \delta > 0$. Based on the above argument, it is necessary to have $V_1 > \dots > V_i = V_{i+1} > \dots > V_j = V_{j+1} > \dots > V_m$ with m going to infinity for some i and j . Since the argument above has already ruled out the possibility of
 10 having subsequences of V_i 's of infinite length between two '=' signs on this list, it must contain an infinite number of '=' signs. Since each '=' sign corresponds to an execution of the case of $W=V$ with probability δ , the probability of executing this step for an infinite number of times is thus zero. Hence, the infinite looping cannot exist.

Although it is possible to treat the case of $W=V$ as reaching a local optimum
 15 (like the case of $W>V$), numerical experience suggests that the case of $W=V$ helps explore various assignments for enhanced results, especially when there are multiple bottleneck APs for the channel assignment under consideration.

Since heuristics is involved in the process 28 for the exemplary algorithm illustrated in FIG. 4, achieving the optimal solution is not guaranteed. It is possible,
 20 however, to quantify the quality of the suboptimal solution generated by the algorithm. It is observed that the processing - in particular, steps 60, 62 and 64 (FIG. 4) - basically tests out various channel assignments to identify a better solution. As the algorithm is executed for a given initial, random assignment, it is possible to let $Y_0, Y_1, Y_2, \dots, Y_m$, denote the (random) sequence of the maximum effective channel utilization associated with the channel
 25 assignments under testing by step 62, with Y_0 denoting the quantity for the initial, random assignment. Based on the Y_i sequence, another sequence $Z_0, Z_1, Z_2, \dots, Z_n$ is constructed as follows: (i) initialize with $Z_0=Y_0$ and set $i=0$; (ii) for each $j=1, 2, \dots, m$, compare Y_j with Z_i ; and (iii) if $Z_i > Y_j$, then set $i=i+1$ and $Z_i=Y_j$; otherwise, repeat (ii) for the next j value.

In essence, the sequence Z_i is constructed by examining Y_j one by one,

starting with $Z_0=Y_0$ and adding Y_j as the last element in the Z_i sequence only if Y_j is less than Y_i for all $i<j$ (or equivalently, Y_j is less than Z_i , the last element in the current sequence). Clearly, the sequence Z_i is monotonic strictly decreasing. Physically, Z_i represents the sequence of the maximum effective channel utilization for an improved
 5 assignment finalized by step 70, or step 74 (FIG. 4) that yields a maximum utilization lower than any assignments examined by the algorithm so far in the search process.

The algorithm is repeated for a given number (say K) of initial random assignments. For each initial assignment, one such sequence Z_i (as discussed above) can be obtained. It can be noted that the sequences associated with different initial assignments
 10 have different lengths and are mutually independent of each other (although elements in the same sequence are dependent). Furthermore, when the algorithm eventually stops, it is assumed that it has encountered a total of n improved assignments (i.e., improved over those examined earlier and derived from the same initial assignment), which is the sum of lengths of the sequences of Z_i minus K .

15 One can view that the maximum effective channel utilization for all possible assignments for the given network has a probability distribution. Allowing T_π to be the maximum utilization for the top- π -fraction of assignments (e.g., the top 0.001 percentile assignments), a random assignment with its maximum utilization Z_0 , gives

$$20 \quad P[Z_0 \leq T_\pi] = \pi \quad \text{Eq. (6)}$$

It can be proven that, if the algorithm has encountered a total of n improved assignments at the completion of its execution, then

$$25 \quad Q_\pi > 1 - (1 - \pi)^{n+1} \quad \text{Eq. (7)}$$

where Q_π denotes the probability that the final suboptimal solution generated by the algorithm falls within the top- π -fraction of assignments. The proof is as follows.

First, the case of encountering n improved assignments for one initial, random assignment is

examined. By definition,

$$Q_{\pi} = P[\min_i Z_i \leq T_{\pi}] = 1 - P[\min_i Z_i > T_{\pi}]. \quad \text{Eq. (8)}$$

5

The event of $(\min Z_i > T_{\pi})$ in the above is identical to having $Z_0 > T_{\pi}$, $Z_1 > T_{\pi}$, ..., and $Z_n > T_{\pi}$. Given that Z_i is a strictly decreasing (random) sequence, then

10

$$P[Z_0 > T_{\pi} \wedge Z_1 > T_{\pi} \wedge \dots \wedge Z_n > T_{\pi}] < P[Z_0 > T_{\pi} \wedge Z_0^1 > T_{\pi} \wedge \dots \wedge Z_0^n > T_{\pi}] \quad \text{Eq. (9)}$$

15

where Z_0^i is a random variable independently drawn from the same distribution for Z_0 for $i=1$ to n . One can obtain Equation (9) by replacing Z_i on the left hand side by Z_0^i on the right side for one i at a time. Since the Z_0^i variables are independent,

$$P[Z_0 > T_{\pi} \wedge Z_0^1 > T_{\pi} \dots Z_0^n > T_{\pi}] = \{P[Z_0 > T_{\pi}]\}^{n+1} \quad \text{Eq. (10)}$$

20

Using the definition in Equation (6), substituting Equation (10) into Equation (9) and then Equation (9) into Equation (8) yields Equation (7). The case with multiple initial random assignments is proved by exploiting the property that the sequences Z_i associated with different initial assignments are mutually independent.

25

The performance of the process 28 is validated by applying the process 28 to two settings of multi-cell networks using the IEEE 802.11 air interface for which the optimal assignment is known. The settings correspond to settings for a seven (7) cell network and thirty-seven (37) cell network.

30

Referring to FIG. 5, an assignment 90 generated by the process 28 for a setting that corresponds to a network with 7 cells is shown. Three adjacent hexagon-shaped sectors 92a, 92b and 92c form a cell 94. Each sector 92 is served by an AP at the center of the cell.

Each AP antenna has a beamwidth of 60° and points toward an appropriate direction to serve the associated sector. Thus, there are 21 APs in the 7 cell network, with 3 APs for each given cell co-located at the cell center, indicated by reference numeral 96.

Similarly, and referring to FIG. 6, an assignment 100 for a setting that
5 corresponds to a network with 37 cells is shown. Three adjacent hexagon-shaped sectors 102a, 102b and 102c form a cell 104. For this setting, there are 111 APs, with 3 APs for each given cell co-located at the cell center, indicated by reference numeral 106.

The antenna gain has a parabolic shape; that is, a 3 dB drop relative to the front
10 direction occurs at the half beamwidth angle. Any direction beyond a threshold angle in clockwise or anti-clockwise direction suffers a given, fixed attenuation relative to the gain at the front direction, which is called the front-to-back (FTB) ratio. The FTB is set to be 25 dB.

It may be recalled that only the AP-to-AP interference is considered in the current formulation. The radio link between any pair of APs in the network is characterized by a path-loss model with an exponential of 3.5. Cell radius is assumed to be 1 Km and the
15 path loss at 100 m from the cell center is -73 dB. Transmission power for each AP antenna is 30 dBm (or 1 W). All APs have an identical amount of offered traffic. It will be noted that the solution generated by the process 28 in this instance does not depend on the actual traffic load, but the feasibility of the final solution does. In order to ensure that the optimal assignment is known, shadowing and fast fading are not considered. In addition, the
20 channel-busy detection threshold α is set to be $2.5e-3 \mu\text{W}$ (which corresponds to -86 dBm). As pointed out earlier, there are 3 non-overlapping channels available in the ISM band for assignment. Based on the parameter settings for both 7 and 37 cell networks, the optimal assignment is the traditional frequency reuse of 3. That is, no adjacent sectors (APs) use the same channel.

25 When the process 28 is applied to the network with 7 cells and 21 APs, as shown in FIG. 5, it generates the optimal channel assignment based on 50 random assignments. The optimal assignment 90 with channels 1 to 3 assigned to the various sectors 92a, 92b and 92c for each cell 94 is as shown in FIG. 5.

As for the network with 37 cells and 111 APs, the process 28 was unable to

yield the obvious optimal assignment of reuse of 3, that is, without considering the boundary effect of the cell layout (which makes the interference conditions non-uniform). The suboptimal solution for channels 1-3 obtained from the process using 1,000 random assignments is the assignment 100 shown in FIG. 6. It can be seen from the assignment 100 that most of the sectors (APs) use a channel different from those in adjacent sectors. In the worst case, at most two adjacent sectors share the same channel. The process encountered and finalized a total of 505,363 improved assignments. Based on the analysis set forth above, with a probability higher than 99.4%, the suboptimal solution, assignment 100, falls within the top 0.001th percentile. This result is quite acceptable.

The above two examples have uniform traffic load and uniform propagation environments with obvious solutions and are only used to verify the correctness of the algorithm. However, for any wireless network of considerable size, the traffic load and the propagation environment are seldom uniform and are usually without obvious channel assignment solutions. The approach of the frequency planning process 28 can easily produce a good (albeit suboptimal) channel assignment solution in such cases, with provable closeness to the optimal solution. Also, if the traffic load is slowly fluctuating over time, the approach can be used to generate a series of channel assignments over time to best accommodate the changing conditions.

Other objective functions can be used in the channel assignment optimization. For example, another objective function (in addition to objective function of Equation (5)) is to minimize the overall interference, that is,

$$\text{minimize} \quad \sum_{i=1}^M U_i \quad (11)$$

over the assignment indicator $\{X_{ij}\}$ subject to the constraints of Equation (4) for all $i=1$ to M . It can be noted that the sum of all U_i reflects the total effective channel utilization. Minimizing the sum tends to minimize the overall interference in the network while maintaining stability of each channel shared and detectable by multiple neighboring APs.

For the optimization with Equation (11) as the objective function, a linear

integer programming approach can be used. For a given network setting, the offered load p_i and the interferer sets $C_i(1)$ and $C_i(2)$ for each AP_i are known. The programming problem is non-linear due to the cross-products of X_{ij} 's in U_i , as defined in Equation (3). Using known techniques - for example, the technique described in the paper by W.W. Chu entitled

5 "Optimal File Allocation in a Multiple Computer System, *IEEE Trans. On Computers*, C-18, No. 10, pp. 885-889, Oct. 1969 - it is possible to linearize the problem by replacing $X_{ik}X_{mk}X_{nk}$ by a new term Y_{ikmn} . Similarly, the term $X_{ik}X_{jk}$ is replaced by a new term Z_{ikj} . The resultant problem becomes a linear integer programming problem, which has been shown to be NP-complete.

10 Yet another objective function is to maximize network throughput.

Other embodiments are within the scope of the following claims. For example, the above-described approach may be extended to consider one or more of the following: non-uniform transmission power by the APs; upstream traffic; overlapping channels (as discussed earlier); real-time adaptive channel assignment to meet the

15 fluctuation of traffic load at various APs over time; inclusion of path gains for stations; and special frequency constraints for individual AP's (e.g., AP closest to a Microwave, WLANs of other carriers).

What is claimed is:

1. A method for frequency planning in wireless networks comprising:
obtaining traffic load information for access points belonging to a multi-cell wireless
5 network; and
assigning channels to the access points based on the traffic load information.
2. The method of claim 1 wherein the step of assigning comprises:
determining, for each access point, at least one set of interferers from among the
other access points relative to the access point.
- 10 3. The method of claim 2 wherein the step of determining comprises:
determining, for each of the other access points, if any co-channel interference by
the other access point is greater than or equal to a detection threshold, the detection
threshold indicative of a busy channel according to the CSMA protocol; and
if it is determined that the co-channel interference is greater than or equal to the
15 detection threshold, identifying the other access point as belonging to the set of interferers
for the access point.
4. The method of claim 3 wherein the co-channel interference is derived from values of
signal path loss between the access point and the other access point and transmission power
of the other access point.
- 20 5. The method of claim 3 wherein the at least one set of interferers comprises a second
set of interferers, and wherein the step of determining comprises:
determining, for each pair of the other access points, if any combined co-channel
interference by such pair is greater than or equal to a detection threshold, the detection
threshold indicative of a busy channel according to the CSMA protocol; and
25 if it is determined that the combined co-channel interference is greater than or equal
to the detection threshold, identifying the other access points in such pair as belonging to the
second set of interferers for the access point.
6. The method of claim 2 wherein the step of assigning further comprises:
generating random channel assignments for the access points;

determining effective channel utilization values for each access point;
modifying the random channel assignment for interferers in the at least one set of
interferers such that the highest one of the effective channel utilization values is minimized;
repeating such modification until the highest one of the effective channel utilization
5 values cannot be reduced by further modification; and
saving the modified random channel assignment as a final assignment.

7. The method of claim 6 wherein the step of assigning further comprises:
providing the final assignment to the access points.

8. The method of claim 2 wherein the step of assigning further comprises:
10 assigning randomly a channel to each of the access points; and
computing, based on the random channel assignment, an effective channel
utilization value for each access point, the effective channel utilization value representing
the sum of an offered load associated with the access point and total traffic load associated
with each set of interferers.

15 9. The method of claim 8 wherein the step of assigning further comprises:
determining which access point has the highest effective channel utilization value;
identifying which channel is assigned to the access point having the highest effective
channel utilization value; and

20 for each access point in the first set of interferers, modifying the random channel
assignment;

recomputing the effective channel utilization value for the modified random channel
assignment; and

repeating modifying and recomputing for each available channel other than the
channel assigned to the access point having the highest effective channel utilization value;

25 determining a minimum effective channel utilization from among the recomputed
effective utilization values;

comparing the minimum effective channel utilization and the recomputed effective
channel utilization values; and

replacing the highest effective channel utilization with the determined minimum effective channel utilization and saving the modified random channel assignment as a best solution if the determined minimum effective channel utilization is lower than the highest effective channel utilization.

- 5 10. The method of claim 9 wherein the step of assigning further comprises:
with a pre-specified probability, replacing the highest effective channel utilization with the determined minimum effective channel utilization and saving the modified random channel assignment as a best solution if the determined minimum effective channel utilization is equal to the highest effective channel utilization.
- 10 11. The method of claim 6 wherein the step of assigning further comprises:
computing an effective utilization value for each access point based on the final assignment; and
determining if the effective utilization value for each access point is less than a value of one.
- 15 12. The method of claim 1 wherein the channels comprise non-overlapping channels.
13. The method of claim 1 wherein the channels comprise overlapping and non-overlapping channels.
14. The method of claim 1 wherein the access points operate in accordance with the IEEE 802.11 standard.
- 20 15. The method of claim 1 wherein the step of assigning comprises:
seeking to minimize effective channel utilization of a most heavily loaded of the access points.
16. The method of claim 1 wherein the step of assigning comprises:
seeking to minimize total effective channel utilization of all access points.
- 25 17. The method of claim 1 wherein the step of assigning comprises:
seeking to maximize network throughput.
18. An article comprising:

a storage medium having stored thereon instructions that when executed by a machine result in the following:

obtaining traffic load information for access points belonging to a multi-cell wireless network; and

5 assigning channels to the access points based on the traffic load information.

19. An apparatus comprising:

a processor; and

a memory storing a computer program product residing on a computer-readable medium comprising instructions to cause a computer to:

10 obtain traffic load information for access points belonging to a multi-cell wireless network; and

assign channels to the access points based on the traffic load information.

20. An access point for use in a multi-cell wireless network comprising:

15 logic configured to obtain traffic load information for access points belonging to the multi-cell wireless network; and

logic configured to assign channels to the access points based on the traffic load information.

1/4

FIG. 1

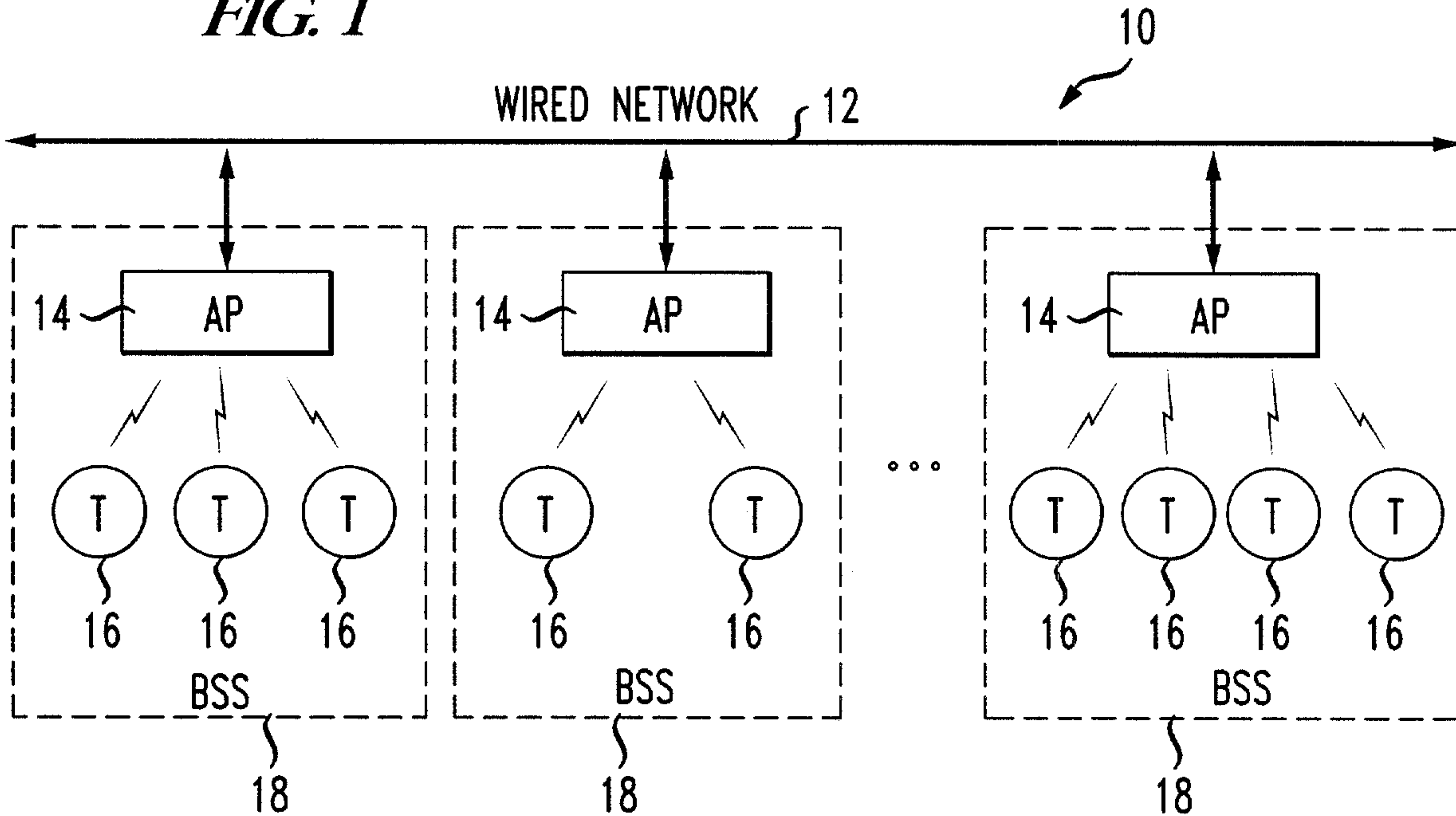
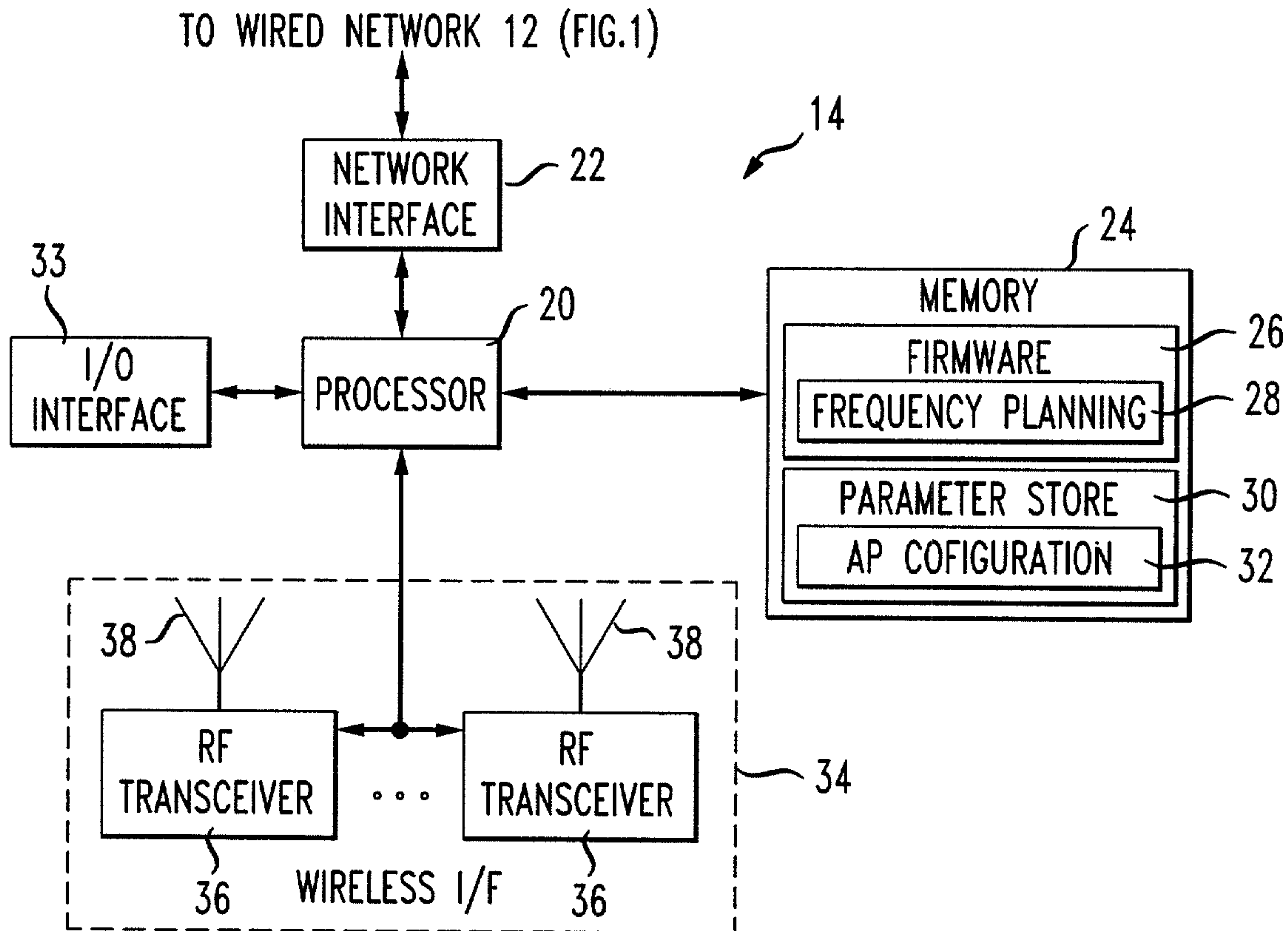

FIG. 2



2/4

FIG. 3

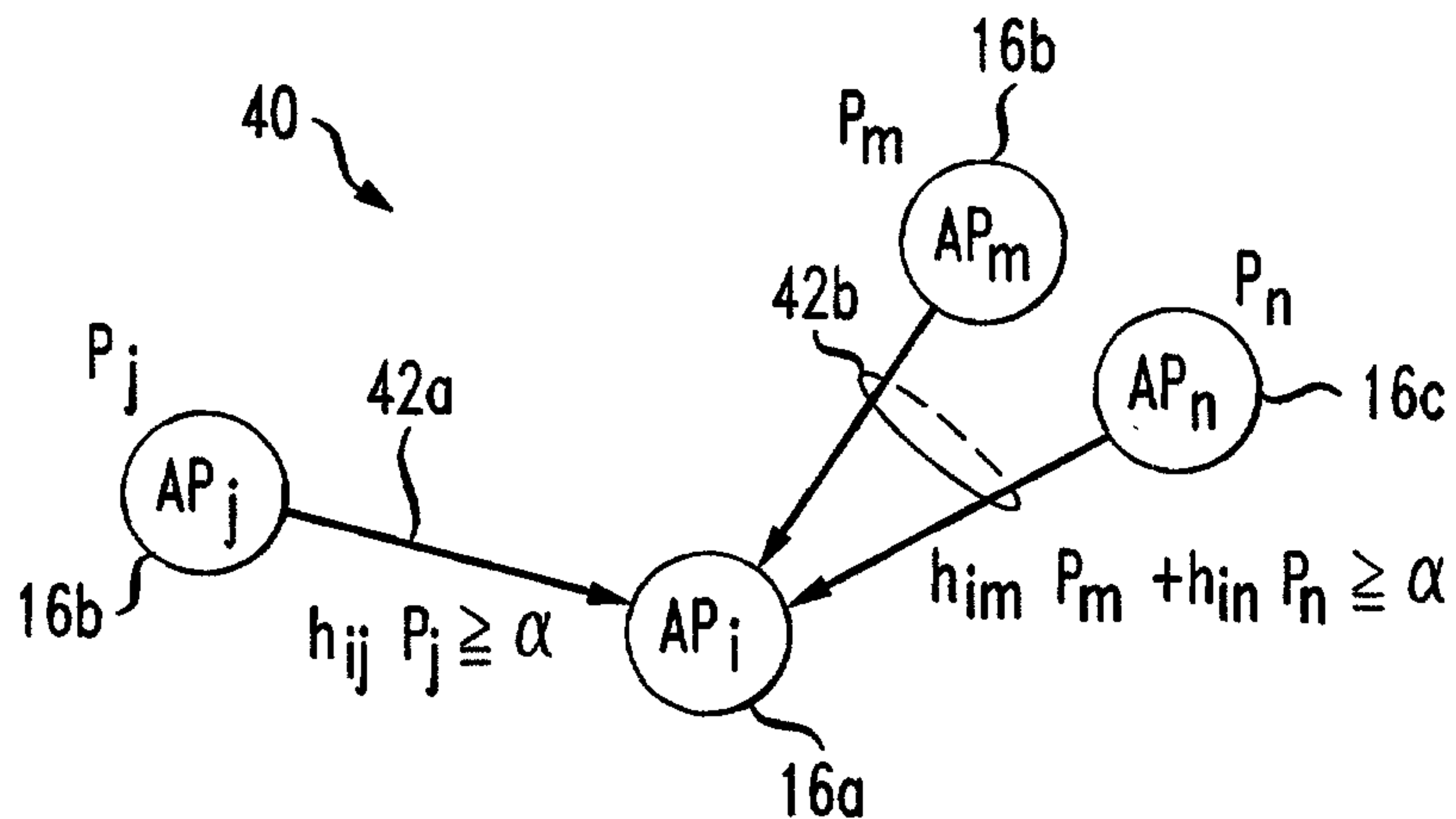
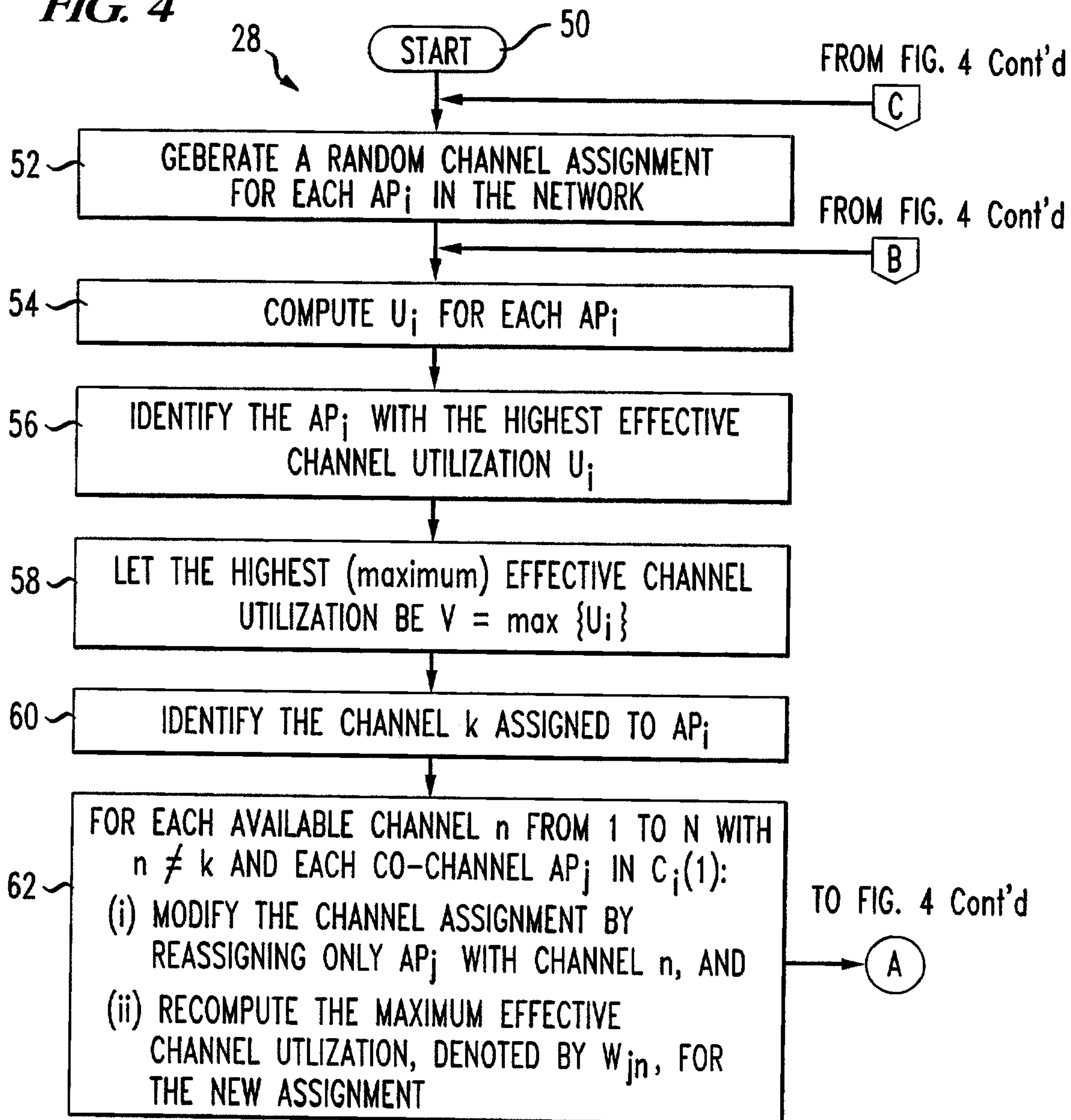
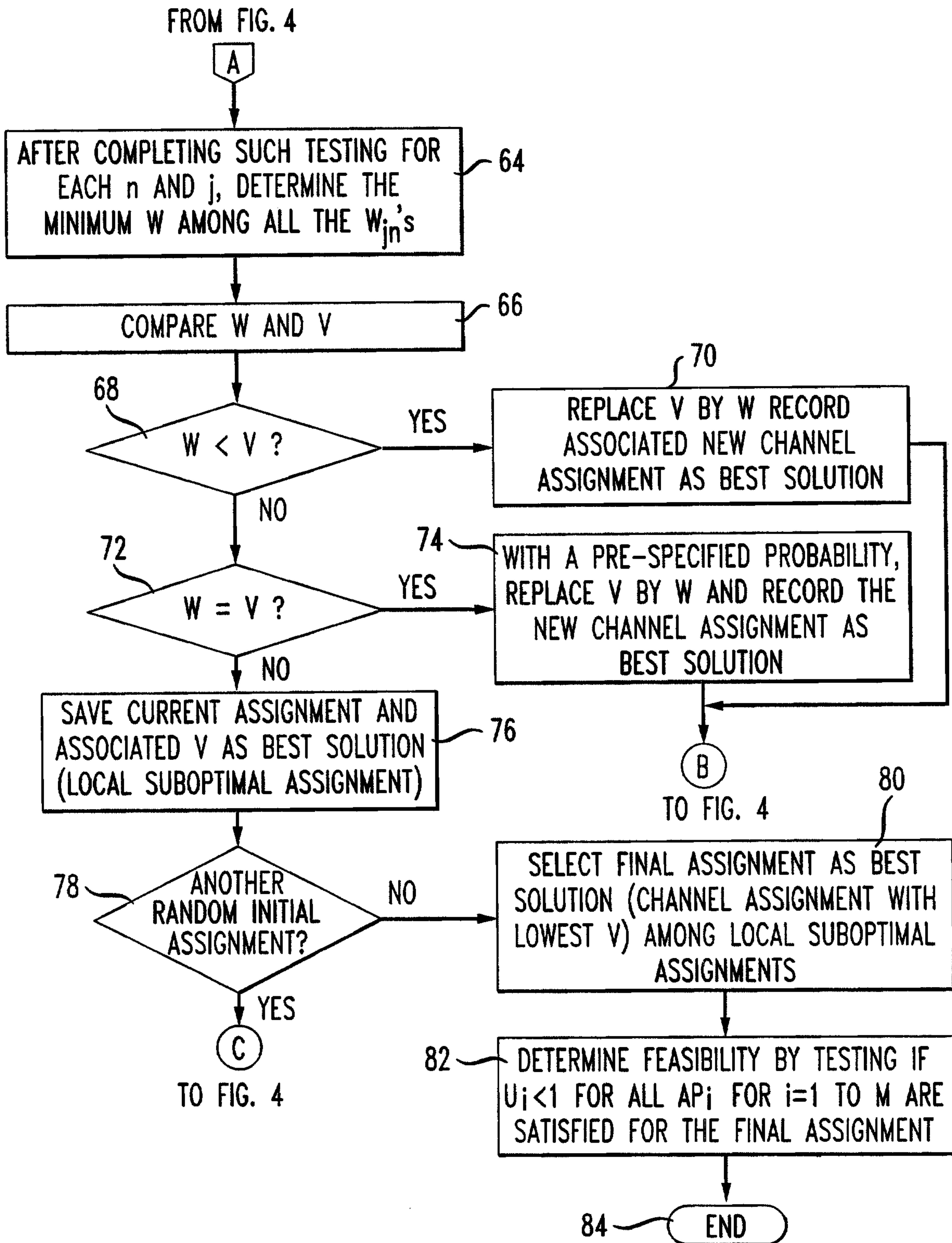

FIG. 4



3/4

FIG. 4 (Cont'd)



4/4

FIG. 5

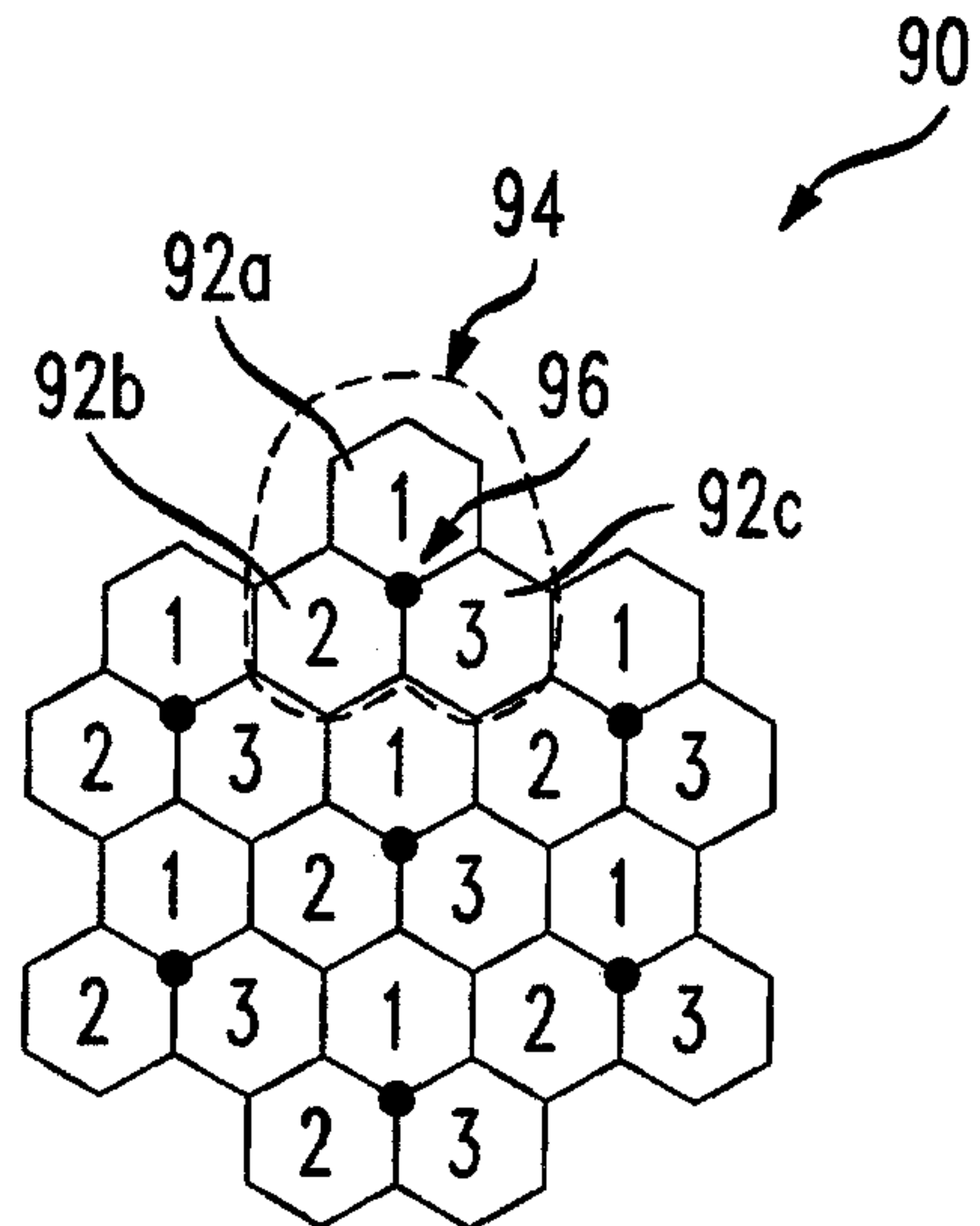
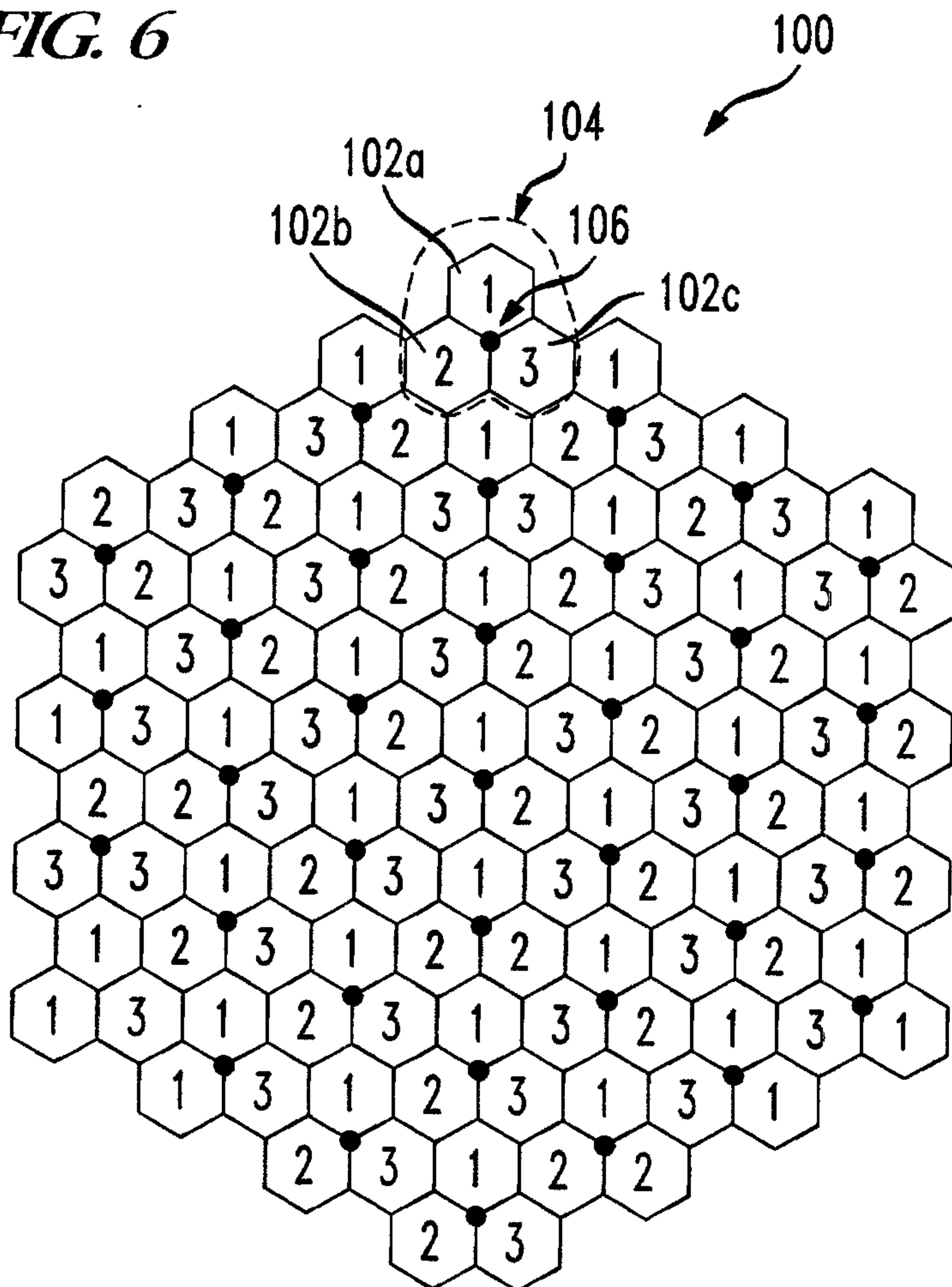

FIG. 6



TO WIRED NETWORK 12 (FIG.1)

