

(19) **DANMARK**

(10) **DK/EP 3762562 T3**



(12) **Oversættelse af
europæisk patentskrift**

Patent- og
Varemærkestyrelsen

-
- (51) Int.Cl.: **E 04 F 13/12 (2006.01)** **E 04 F 13/07 (2006.01)** **E 04 F 13/08 (2006.01)**
E 04 F 13/18 (2006.01)
- (45) Oversættelsen bekendtgjort den: **2023-10-09**
- (80) Dato for Den Europæiske Patentmyndigheds bekendtgørelse om meddelelse af patentet: **2023-09-06**
- (86) Europæisk ansøgning nr.: **18908617.6**
- (86) Europæisk indleveringsdag: **2018-10-16**
- (87) Den europæiske ansøgnings publiceringsdag: **2021-01-13**
- (86) International ansøgning nr.: **US2018056131**
- (87) Internationalt publikationsnr.: **WO2019172963**
- (30) Prioritet: **2018-03-09 US 201815916952**
- (84) Designerede stater: **AL AT BE BG CH CY CZ DE DK EE ES FI FR GB GR HR HU IE IS IT LI LT LU LV MC MK MT NL NO PL PT RO RS SE SI SK SM TR**
- (73) Patenthaver: **Fairview Architectural, LLC, 75 Peters Road, Bloomfield CT 06002, USA**
- (72) Opfinder: **SIMONSEN, David, 13360 Bear Mountain Rd., Redding, CA 96003, USA**
- (74) Fuldmægtig i Danmark: **Plougmann Vingtoft A/S, Strandvejen 70, 2900 Hellerup, Danmark**
- (54) Benævnelse: **DOBBELTRETURPANELSYSTEM**
- (56) Fremdragne publikationer:
EP-A2- 0 531 869
US-A- 5 809 729
US-A1- 2004 123 550
US-A1- 2009 145 071
US-A1- 2009 241 451
US-A1- 2015 345 152
US-A1- 2016 298 338
US-B1- 9 903 123

DESCRIPTION

BACKGROUND OF THE INVENTION

[0001] The present application relates to a novel and useful double return panel system employed to clad or cover a facade .

[0002] In the past, many systems have been proposed to attach panels to a facade. For example, the systems found in United States Patents 9,777,486 and 9,903,123 represent significant advances in the field of panel mounting systems.

[0003] In the construction arts, it is imperative that panel mounting systems allow for efficient installation and reduction in costs associated with materials and labor. It is also important that panel mounting systems be compatible with existing panel mounting apparatuses, while maintaining the advantages of moisture control, thermal contraction and expansion, and aesthetic appearance.

[0004] A panel mounting device or system which minimizes component parts and reduces the intensity of the labor required for installation would be a notable advance in the construction field.

[0005] US 2015/345152 A1 discloses a panel system for covering a building wall using a device according to the preamble of claim 1.

SUMMARY OF THE INVENTION

[0006] In accordance with the present application, a novel and useful device as defined in claim 1 for attaching panels to a facade is herein provided.

[0007] The device of the present application utilizes a support or perimeter extrusion that possesses an arm terminating in an end that is constructed to contact a panel and permit the bending of the same in two directions. Such device may be referred to as perimeter extrusion and does not require screws, rivets, structural tape, or adhesives, such as caulk, for assembling of the same with paneling material.

[0008] Such perimeter extrusion panel is also ideally formed with a surface that possesses a removed portion formed by scoring or routing.

[0009] The perimeter extrusion also is fashioned with a platform that is contiguous with the arm and separates from the arm to form a slot. The slot is configured to capture a portion of

the panel that has been bent by the arm end portion. Also, the slot may be formed by a wall having a serrated surface that permits positive gripping of a bent portion of the panel to fix the same in place.

[0010] According to the invention the end portion of the arm includes a prong that interacts with the removed portion of the panel to affect such bending and placement of a portion of the panel within the slot formed by the perimeter extrusion. It can further include an enlargement.

[0011] In addition, a leg that is contiguous with the platform extends outwardly from the platform.

[0012] A base is also included in the device of the present application and a first fastener holds the same to the facade. The leg of the perimeter extrusion lies closer to the base than to the platform.

[0013] The leg may also be formed with an aperture that accepts a second fastener in order to hold the leg to the base. Said base may take the form of a U-shaped member allowing spacing of adjacent perimeter extrusions and permitting thermal contraction and expansion of the panels in a predetermined direction.

[0014] In addition, the perimeter extrusion may also be provided with a shelf that is positioned outwardly from the slot but lies closer to the base than the slot. The shelf may be used to support a reveal strip used to occupy the space between adjacent perimeter extrusions supporting multiple panels .

[0015] Moreover, the perimeter extrusion may also be constructed with a flange that extends outwardly from the leg in opposition to the shelf. Such flange may be used to aid in the formation of a frame in which such flanges are placed in overlapping configuration for structural integrity. In addition, stiffeners may be employed within such frame in crisscross manner, with or without the use of mechanical fasteners. Such stiffeners also prevent the perimeter extrusions used therein to bend away from or disengage from the facade material. In certain configurations, the device of the present application may be employed to allow the placement of panels in overlapping rather than side-by-side configurations, either on a vertical or horizontal surface.

[0016] It may be apparent that a novel and useful device for the attaching of a panel or panels to a facade has been hereinabove described.

[0017] It is therefore an object of the present application to provide a device for attaching a panel to a facade that provides a double return panel system requiring a minimum of one extrusion to assemble a panel array without screws, rivets, structural tape, or caulk.

[0018] It is another object of the present application to provide a device for attaching a panel to a facade that requires a minimum amount of labor to install the same. Another object of the

present application is to provide a device for attaching a panel to facades of varying compositions .

[0019] Another object of the present application is to provide a device for attaching a panel to a facade resulting in a double return panel system employing a universal perimeter extrusion that can also be used as a stiffener extrusion .

[0020] Another object of the present application is to provide a device for attaching a panel to a facade that can be used on a vertical or horizontal orientation.

[0021] Another object of the present application is to provide a device for attaching a panel to a facade resulting in a double return panel system that utilizes cladding that may be formed of materials such as aluminum composite material (ACM) , metal composite material (MCM) , plate or sheet materials, insulated panels, and the like.

[0022] Another object of the present application is to provide a device for attaching a panel to a facade which is compatible with prior art mounting systems.

[0023] Another object of the present application is to provide a device for attaching a panel to a facade that accommodates the use of a reveal strip that is located immediately adjacent to a portion of a panel, allowing for minimal static friction effects, resulting in better thermal movement of the system.

[0024] Another object of the present application is to provide a device for attaching a panel to a facade that provides a double return panel system utilizing a clevis pin which can be used for both vertical and horizontal mounting.

[0025] Another object of the present application is to provide a device for attaching a panel to a facade that permits the use stiffeners without full length portions of tape or caulk. Another object of the present application is to provide a device for attaching a panel to a facade that permits to assemblage if a frame through the interaction of perimeter extrusions having overlapping corners, saving time and materials in the installation of the same.

[0026] Another object of the present application is to provide a device for attaching a panel to a facade which may include a double return panel system having stiffeners that may be crisscrossed to provide strength to a frame formed from perimeter extrusions.

[0027] Another object of the present application is to provide a device for attaching a panel to a facade in which a perimeter extrusion acts as a folding tool to permit bending of the panel resulting in a double return panel system.

[0028] Another object of the present application is to provide a device for attaching a panel to a facade which anticipates the use of insulated materials held beneath the cladding elements,

without fasteners or adhesives, preventing delamination of certain panels.

[0029] Another object of the present application is to provide a device for attaching a panel to a facade that results in a double return panel system that can be economically fabricated and installed and possesses increased aesthetics due to a shorter reveal depth between adjacent panels .

[0030] Another object of the present application is to provide a device for attaching a panel to a facade that facilitates the connection of a perimeter extrusion to a base member utilizing hook-and-pin style construction.

[0031] Another object of the present application is to provide a device for attaching a panel to a facade in which a perimeter extrusion includes a fishtail end portion which locks into a V-groove formed in the cladding material that eventually sandwiches the cladding material forming a double return panel system.

[0032] Another object of the present application is to provide a device for attaching a panel to a facade that uses a O-shaped base member mounted to the facade and where multiple perimeter extrusions are fastened to the U-shaped member that controls thermal expansion in a predetermined direction.

[0033] Another object of the present application is to provide a device for attaching a panel to a facade that possesses a U-shaped channel as a base member that includes indicia aiding the installer in proper positioning of fasteners utilized to connect the U-shaped member to the facade .

[0034] Another object of the present application is to provide a device for attaching a panel to a facade in which a perimeter extrusion provides a slot having teeth or serrations to hold a portion of the bent panel positively to the perimeter extrusion.

[0035] Yet another object of the present application is to provide a device for attaching a panel to a facade that utilizes a base member confining a perimeter extrusion supporting a panel into thermal contraction and expansion in a predetermined direction.

[0036] The invention is as defined in the appended claims, however it possesses other objects and advantages especially as concerns particular characteristics and features within the scope of these claims which will become apparent as the specification continues.

BRIEF DESCRIPTION OF THE SEVERAL VIEWS OF THE DRAWINGS

[0037]

FIG. 1 is a side elevational view of an example of a perimeter extrusion utilized in the device of the present application . FIG. 2 is a side elevational view of another example of a perimeter extrusion utilized in the present application

FIG. 3 is a side elevational view of another example of a perimeter extrusion utilized in the present application

FIG. 4 is a side elevational view of another example of a perimeter extrusion utilized in the present application

FIG. 5 is a side elevational view of a perimeter extrusion utilized in the present application with an insulated member.

FIG. 6 is a side elevational view of another example of a perimeter extrusion utilized in the present application

FIG. 7 is a side elevational view of another example of a perimeter extrusion utilized in the present application

FIG. 8 is a side elevational view of another example of a perimeter extrusion utilized in the present application

FIGS. 9A-9C illustrate the steps for installation of a panel in conjunction with the perimeter extrusion shown in FIG. 1.

FIG. 10 is a side elevational view of a portion of the perimeter extrusion taken along line 10-10 of FIG. 1.

FIG. 11 is a side elevational view of a pair of perimeter extrusions shown in the embodiment of FIG. 1 with a pair of panels, a base member, and a reveal strip, shown in section . FIG. 12 is a partial top plan view of the illustration depicted in FIG. 11.

FIG. 13 is a right side front top perspective view of a quartet of perimeter extrusions forming a frame.

FIG. 14 is a side elevational view of a multiplicity of perimeter extrusions mounting a panel system on a vertical facade .

[0038] For a better understanding of the application, reference is made to the following detailed description of the preferred embodiments thereof which should be referenced to the prior described drawings.

DETAILED DESCRIPTION OF THE PREFERRED EMBODIMENTS

[0039] Various aspects of the present application will evolve from the following detailed

description of the preferred embodiments which should be taken in conjunction with the prior delineated drawings.

[0040] The extrusion of the panel attaching device according to the invention as a whole is shown in the drawings by reference character 10, with various examples denoted with the addition of an uppercase letter.

[0041] Referring now to FIG. 1, it may be observed that an example 10A of a perimeter extrusion is shown in whole. Example 10A includes an arm 12 terminating in an end portion 14. End portion is formed with prongs, fins, or tips 16 and 18, generally on the form of "fishtail". End portion 14 is employed to engage a panel 20, shown in phantom in FIGS. 1-8. Panel 20 includes removed portions to facilitate bending by end portion 14 of arm 12 of device 10A, which is best illustrated in FIG. 9A. Device 10A is also provided with a platform 22 which is contiguous with arm 12 and spaced therefrom to form a slot 24. Wall portion 26, surrounding slot 24, includes a serrated surface 28, which is used to grip part 30 of panel 20. It should also be noted that end part 32 of panel lies across end portion 14 of device 10, contacting prongs 16 and 18.

[0042] Device 10 further possesses a shelf 34 which is intended to hold a reveal strip 36. Again, reveal strip 36 is shown in FIGS. 1-8 in phantom, and is best shown as a whole in FIG. 9C and FIG. 11. Device 10A is further constructed with a leg 38, which is intended to connect to the facade of the structure via a base member, which will be discussed hereinafter, and is best shown in FIG. 11. Flange 40 projects from device 10 in a direction opposite to shelf 34, the function of which will be discussed as the specification continues. It should be realized that arm 12, platform 22, shelf 34, leg 38, and flange 40 are contiguous in device 10A. Turning now to FIG. 2, example 10B of the perimeter extrusion is depicted. Device 10B is similar to device 10A except that leg 42 includes an end portion 44, which is compatible with prior art fixation mechanisms used to attach example 10B to a facade. For example, end portion 44 may be employed with the fixation mechanism shown in U.S. Patent 9,903,123.

[0043] Also, a shelf 46 is included which extends from embodiment 10B and is slightly tilted upwardly to provide support for reveal strip 36 against end part 30 of panel 20.

[0044] In addition, a spacer 47 extends from slot 24 to maintain frictional engagement between panel 20 and reveal 36.

[0045] FIG. 3 reveals another example 10C of the device of the present application in the form of a perimeter extrusion in which an arm 48 includes an end portion 50 having a corner 52 that, again, allows for the easy bending of panel 20. Elbow 33 also serves to further bend panel 20 to form end part 30. Again, end part 30 of panel 20 lies in a slot 54 and a shelf 56 supports reveal strip 36. Leg 58 is similar to leg 38 of FIG. 1. A fastener 60 is shown as being an option to hold end part 30 of panel 20 within slot 54.

[0046] FIG. 4 shows another example 10D of a perimeter extrusion of the device of the

present application.

[0047] Example 10D possesses an end portion 62, which is similar to end portion 48 of example 10C of FIG. 3. Slot 64 includes a serrated surface 66 and a wall 68 having a turned end 70. Wall 72 extends outwardly from leg 74 and holds reveal strip in place with turned end 70 of wall 68.

[0048] FIG. 5 illustrates another example 10E of the perimeter extrusion of the device of the present application in which a leg 76 terminates in a prong 78 that allows the bending and forming of portions 30 and 32 of panel 20.

[0049] Portion 30 fits within slot 80 having a serrated surface 82.

[0050] An insulated element 84 lies adjacent part 32 of panel 20 and under surface 86 of panel 20. Corner 86 of insulated element 84 aids in the bending of panel 20, although a second prong similar to prong 78 may be extended upwardly to substitute for corner 86 of insulated element 84. Flange 88 projects outwardly from shelf 84. Leg 90, similar to leg 74, FIG. 4, extends downwardly for connection to a base member, to be described hereinafter.

[0051] Viewing now FIG. 6, another example 10F of the perimeter extrusion of the device of the present application is shown. Device 10F shows a leg 92. Leg 92 includes prongs or fins 94 and 96, which are spaced apart from each other a greater distance than the prongs depicted in FIG. 1 with respect to example 10A. Thus, panel section 98 is formed creating a greater depth for the placement of reveal strip 36 on shelf 100. Slot 102 takes a form similar to slot 80 of FIG. 5

[0052] FIG. 7 reveals another example 10G of the perimeter extrusion of the device of the present application in which arm 104 possesses an end portion 106 which is approximately hemispherical. Panel 108 is formed with a removed or relieved portion 110, which is created by any suitable mechanical tool, such as a router. Panel 108 is then bent around end portion 106 to create an end part 114 that fits within slot 112. Directional arrow 116 indicates such bending action while directional arrow 118 shows the downward positioning of panel 108 around leg 104. Leg 120 and flange 122 are similar in structure to such elements shown in FIG. 1 with respect to embodiment 10A.

[0053] Looking at FIG. 8, another example 10H of the perimeter extrusion of the device of the present application is depicted. Device 10H is made with an arm 124 and is used in conjunction with panel 108 of FIG. 7. End portion 126 of arm 124 is approximately T-shaped and allows the bending of panel 108 around arm 124 such that panel and part 112 fits within slot 128.

[0054] FIGS. 9A-9C delineate the steps involved in the operation of the bending and securing of a panel 130 causing a perimeter extrusion similar to the extrusion depicted as example 10A of FIG. 1. Consequently, the elements of the extrusion shown in FIGS. 9A-9C will bear the same reference characters shown in FIG. 1. Panel 130 is formed with an end part 132 which

lies adjacent to a relieved or removed portion 134. Removed portion 134 possesses crevices 136 and 138.

[0055] Initially, end part 132 of panel 130 is placed in slot 124 such that crevice 138 bears against prong 18 of end portion 14 of arm 12, FIG. 9A. Fig. 9B shows the turning, bending, or folding of panel 130 such that channel 136 contacts prong 16 of arm 12. Directional arrow 140 indicates the turning, bending, or folding movement of panel 130. FIG. 9C shows panel 130 in its finished condition after panel 130 has been folded via prong 16 in crevice 136, such that panel part 132 lies within slot 24 and panel part 142 lies against prong end portion 14 of arm 12. Thus, perimeter extrusion 10A serves as a folding tool that remains adjacent panel 130 after employment. It should be noted that an optional double sided tape layer 142 is pictured as lying atop shelf 34, FIGS. 9B and 9C, in order to rest against reveal strip 36 placed on shelf 34, according to directional arrow 144, FIG. 9C. Also, double-sided tape or caulk may be inserted between arm 12 and the underside of panel 130 to stabilize movement therebetween.

[0056] FIG. 10 illustrates the side portion of leg 38 of example 10A of FIG. 1 and other legs of examples 10B-10H that are similar in FIGS. 2-8. Apertures 146 and 148 are shown as well as opening 150 therethrough. Apertures 146 and 148 as well as opening 150 are intended to interact with base 152 shown in FIGS. 11 and 12. Base or channel 152 is held to facade 154 by a positioning fastener 156. Base 152 includes bottom surface 157 and extending walls 159 and 161. A locating groove 158 in surface 157 aids in the placement of fastener 156 at the base 160 of channel 152. Grooves 162 and 164 along walls 159 and 161, respectively, aid in marking the placement of clevis pin 166, which extends through a drilled hole (not shown) through base 152. Clevis pin 166 is exemplary of a multiplicity of clevis pins which may be used along channel 152. It should be noted that the apertures 146 and 148 of FIG. 10 of leg 38 are intended to interact with clevis pin 166 as well as others used therein. It should also be realized that the placement of fastener 156 forms a gap "A", FIG. 12, between leg 38 and channel 152. Thus, leg 168 of device 10A1 is fixed such that the thermal expansion and contraction of panel 201 is confined to directions along arrow 170, since leg 168 is held between channel 152 and positioning fastener 156. In other words, fastener 156 prevents movement of leg 168 outside gap "A". Of course, other positioning fasteners may be used along groove 158 to maintain this confinement of extrusion panel 10A1. The same holds true for other panels used in the system depicted in FIGS. 11 and 12, including, panel 20, which is held to a similar channel to channel 52 (not shown) and is thus allowed to expand according to directional arrow 172.

[0057] A frame 174 may be formed with perimeter extrusions 176, 178, 180, and 182, FIG. 13. Each perimeter extrusion, as shown in FIG. 13, is similar to the example depicted as 10A in FIG. 1. It should be also seen that flanges 184 of perimeter extrusions 176 and 178 overlap each other at the corner 188 of frame 174. Fasteners may be used at such overlay location to hold perimeter extrusions 176 and 178 together (not shown). Such flanges correspond to flange 40 of FIG. 1. Perimeter extrusions 176, 178, 180, and 182 are also depicted without attached panels and apertured side portions of legs for the sake of simplicity. Stiffeners 190 and 192 may also be used with frame 174 and are positioned flat side- to-flat side thereat. An optional fastener 194, may also be employed to fix stiffeners 190 and 192 to each other and to

facade 154. Also, fasteners may be employed to hold stiffeners to perimeter extrusions 176, 178, 180, and 182. Exemplar flange 184 of perimeter extrusion 176 may be used for this purpose.

[0058] Turning to FIG. 14, it may be observed that panels 196, 198, and 200 are positioned in overlapping configuration along a vertical facade 202. Perimeter extrusions 202, 204, and 206 support panels 196, 198, and 200 in this position, and are held to facade 202 by fasteners 208, 210, and 212.

[0059] In operation, any one of the perimeter extrusions 10A-10H of FIGS. 1-8 may be employed with properly routed panels such as panel 20. With reference to FIGS. 9A-9C, it may be observed that a panel 130, similar to panel 120, is used and fits within slot 24. Crevice 138 of panel 130 also bears against prong 18 of end portion 14 of arm 12 of example 10A. Panel 130 is then raised upwardly to effect the first bend such that prong 16 contacts crevice 136 and then is further bent such that the remainder of panel 130 lies atop arm 12 when panel 130 is bent over prong 16. Reveal 36 is then slipped below portion 132 of panel 130 on shelf 134. Double sided tape 142 may be optionally used to further fix panel 130 in place. Once assembled, perimeter extrusions 10A- 10H firmly hold any panels, such as panel 20, in place at facade 154.

REFERENCES CITED IN THE DESCRIPTION

Cited references

This list of references cited by the applicant is for the reader's convenience only. It does not form part of the European patent document. Even though great care has been taken in compiling the references, errors or omissions cannot be excluded and the EPO disclaims all liability in this regard.

Patent documents cited in the description

- [US9777486B \[0002\]](#)
- [US9903123B \[0002\] \[0042\]](#)
- [US2015345152A1 \[0005\]](#)

Patentkrav

1. Indretning (10) til fastgørelse af et panel på en facade, omfattende en ekstrudering med:

5 en arm (12), idet nævnte arm (12) slutter i en ende, idet nævnte ende er konstrueret til at kontakte panelet og tillade bøjning af panelet derover;
en platform (22), idet nævnte platform (22) støder op til nævnte arm (12) og strækker sig fra nævnte arm (12), idet nævnte platform (22) yderligere er anbragt med afstand til nævnte arm (12) for at danne en spalte, idet
10 nævnte spalte (24) er konfigureret til at fange en del af panelet;
et ben (38), idet nævnte ben (38) støder op til nævnte platform (22) og strækker sig udad derfra;
hvor indretningen (10) omfatter:
en base (152); idet nævnte ben (38) ligger tættere på nævnte base end på
15 nævnte platform;
en første fastgørelsesanordning til at holde nævnte base til facaden; og
en anden fastgørelsesanordning til at holde nævnte ben til nævnte base;
kendetegnet ved, at
nævnte endedel (14) af nævnte arm (12) yderligere omfatter en spids (16,
18, 78) til at komme i kontakt med nævnte panel og tillade bøjning af
20 panelet omkring nævnte spids.

2. Indretningen (10) ifølge krav 1, hvor endedelen (14) af armen (12)r omfatter en yderligere spids (16, 18, 78), hvor de to spidser (16, 18, 78) er konfigureret til at komme i kontakt med panelet og tillader en første bøjning af panelet omkring
25 nævnte spids og en anden bøjning af panelet omkring nævnte yderligere spids.

3. Indretningen (10) ifølge krav 1, som yderligere omfatter en hylde (34), idet nævnte hylde (34) er placeret udad fra nævnte spalte (24) og ligger tættere på nævnte base (152) end nævnte spalte (24).

30

4. Indretningen (10) ifølge krav 3, som yderligere omfatter en afdækningsstrimmel monteret på nævnte hylde (34).

5. Indretningen (10) ifølge krav 1, hvor nævnte spalte (24) er dannet af en væg, idet nævnte væg inkluderer en takket overflade, der strækker sig ind i nævnte spalte (24).

5 **6.** Indretningen (10) ifølge krav 1, hvor nævnte ben (38) yderligere omfatter en åbning, der strækker sig derigennem, idet nævnte anden fastgørelsesanordning strækker sig gennem nævnte åbning (146, 148).

7. Indretningen (10) ifølge krav 3, som yderligere omfatter en flange (40), der er
10 forbundet med og strækker sig fra nævnte ben (38) modsat nævnte hylde (34) og en afstandsholder placeret mellem nævnte panel og nævnte afdækningsstrimmel.

8. Indretningen (10) ifølge krav 3, hvor nævnte hylde (34) er orienteret opad fra nævnte base (152) og strækker sig i en retning væk fra nævnte base (152).

15

9. Indretningen (10) ifølge krav 1, som yderligere omfatter et isoleringselement støttet på nævnte arm.

10. Indretningen (10) ifølge krav 1, hvor nævnte base omfatter en overflade
20 (28), idet nævnte overflade (28) inkluderer en markering til at lokalisere nævnte første fastgørelsesanordning.

11. Indretningen (10) ifølge krav 1, hvor nævnte endedel (14) af nævnte arm (12) omfatter en udvidelse, konfigureret til at interagere med en fjernet del af
25 nævnte panel under bøjningen af nævnte panel.

12. Indretningen (10) ifølge krav 1, hvor nævnte panel omfatter en overflade, der har en fjernet del; og
hvor nævnte ende af nævnte arm (12) er konstrueret til at kontakte nævnte
30 paneloverflade ved nævnte fjernede del.

13. Indretningen (10) ifølge krav 1, hvor nævnte base (152) inkluderer en overflade og en basisvæg, der strækker sig fra nævnte overflade, og nævnte første fastgørelsesanordning danner et mellemrum (A) mellem nævnte første
35 fastgørelsesanordning og nævnte basisvæg, idet nævnte mellemrum (A) er

dimensioneret til at begrænse bevægelse af nævnte ben af nævnte ekstrudering inden i nævnte spalte (A).

- 14.** Indretningen ifølge krav 1, hvor nævnte endedel af nævnte arm er
5 konfigureret som et bukkeværktøj.

DRAWINGS

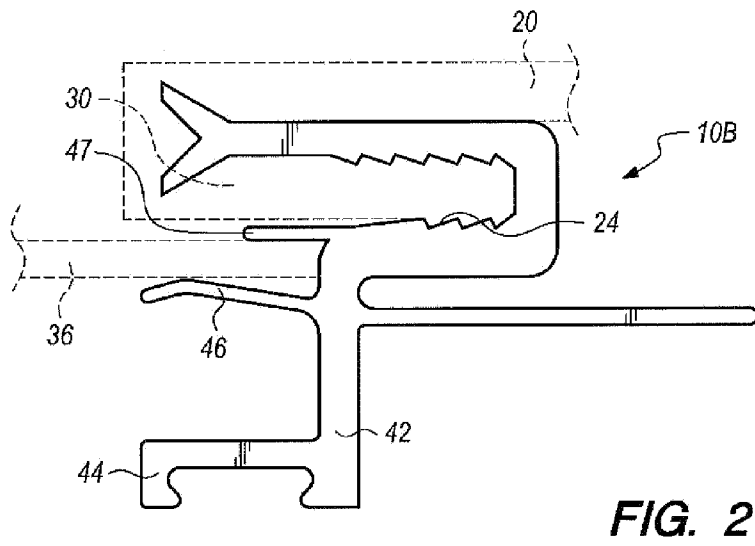
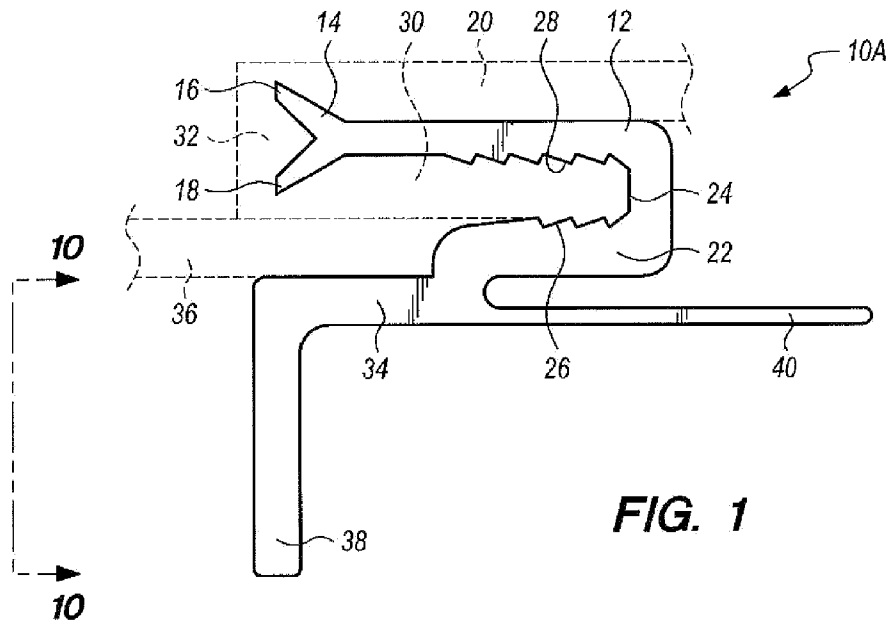

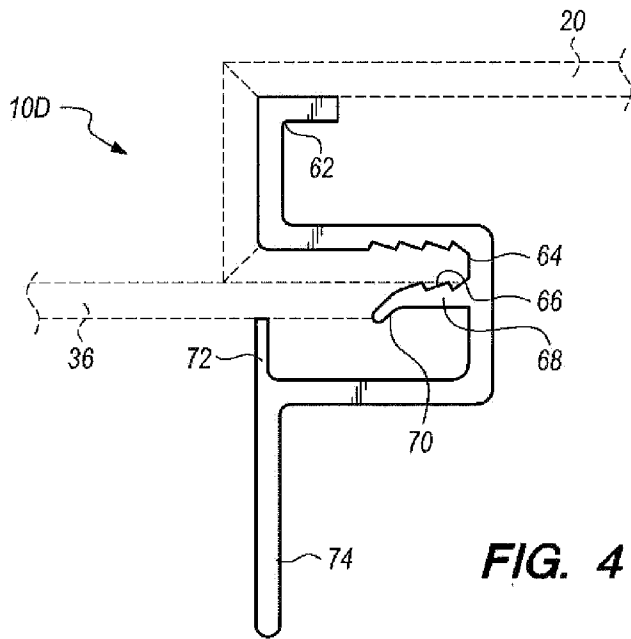
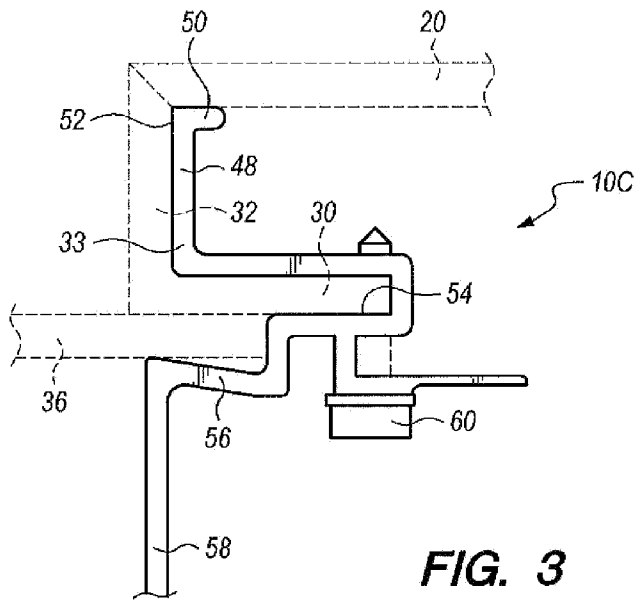

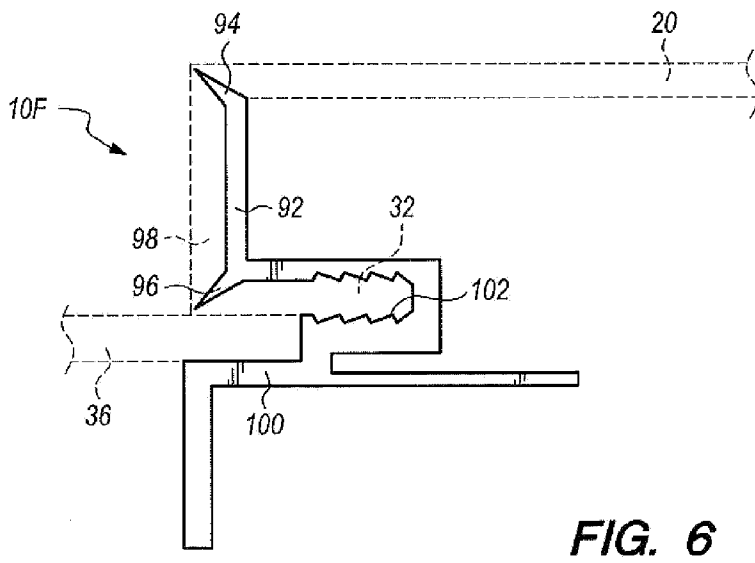
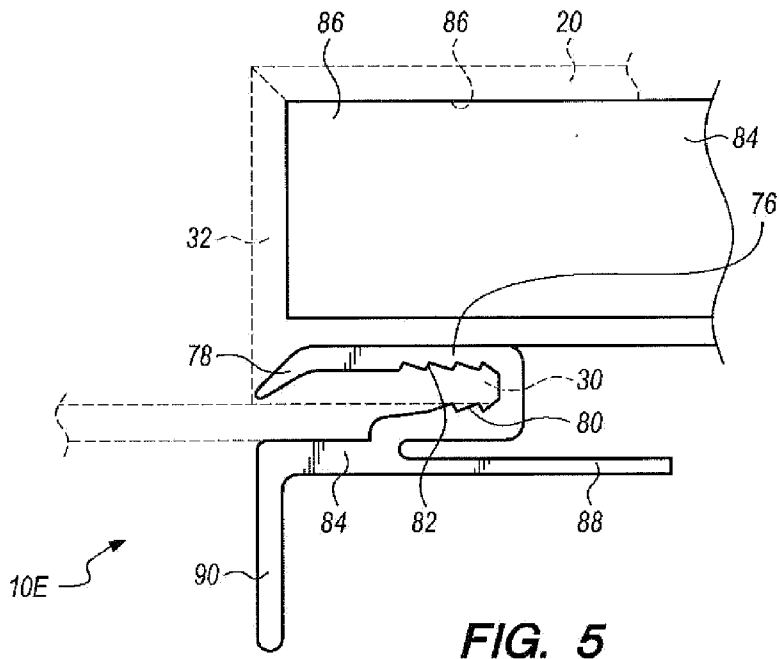

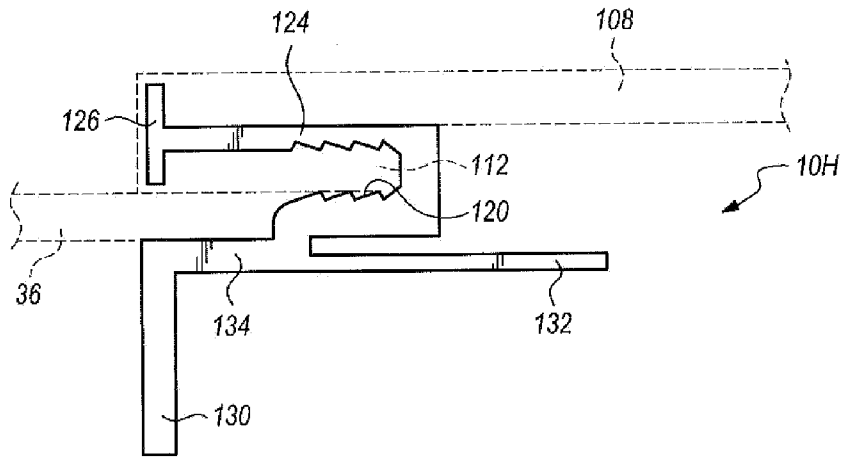
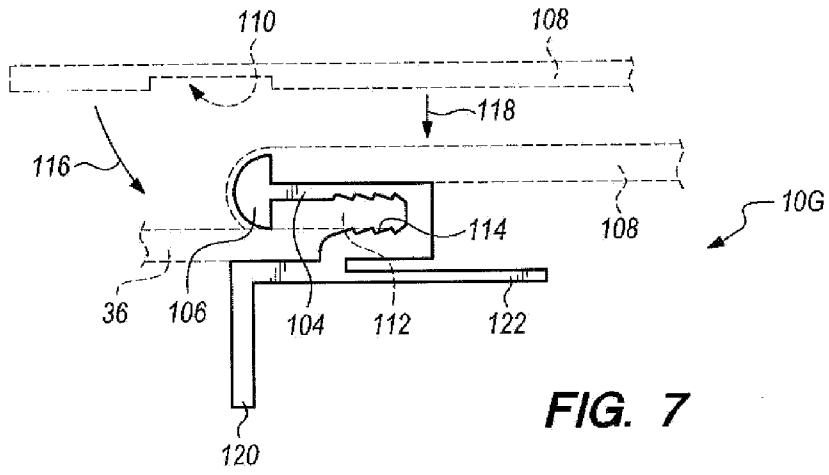

FIG. 9A

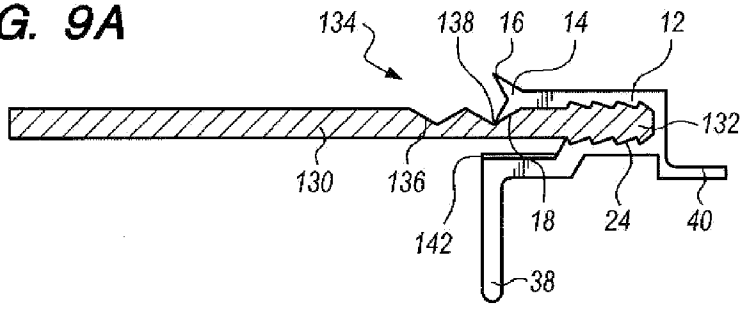
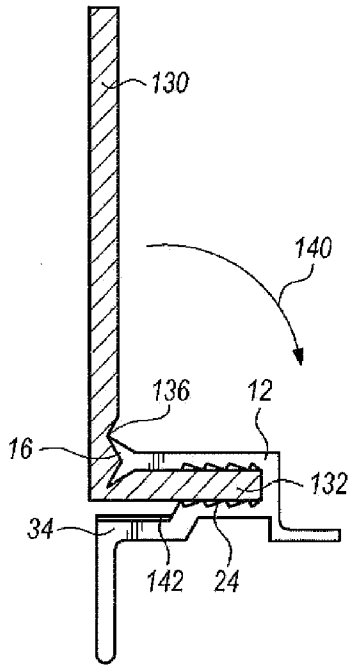

FIG. 9B



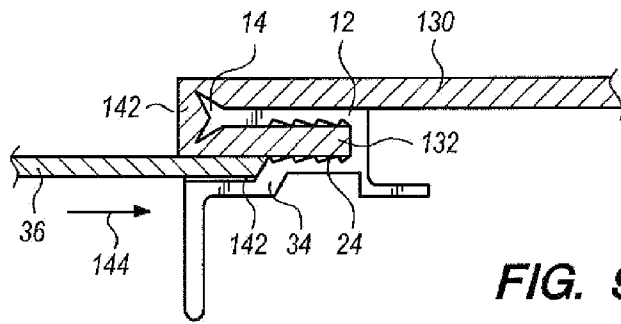

FIG. 9C

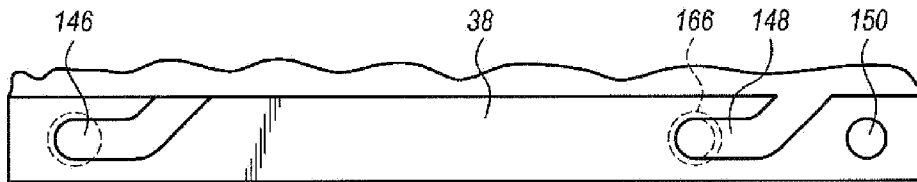
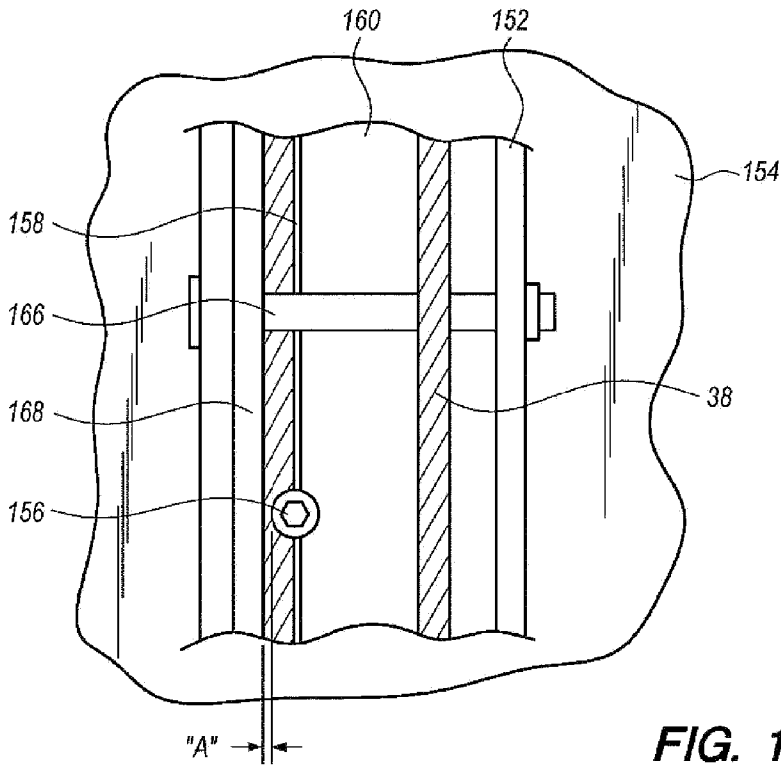
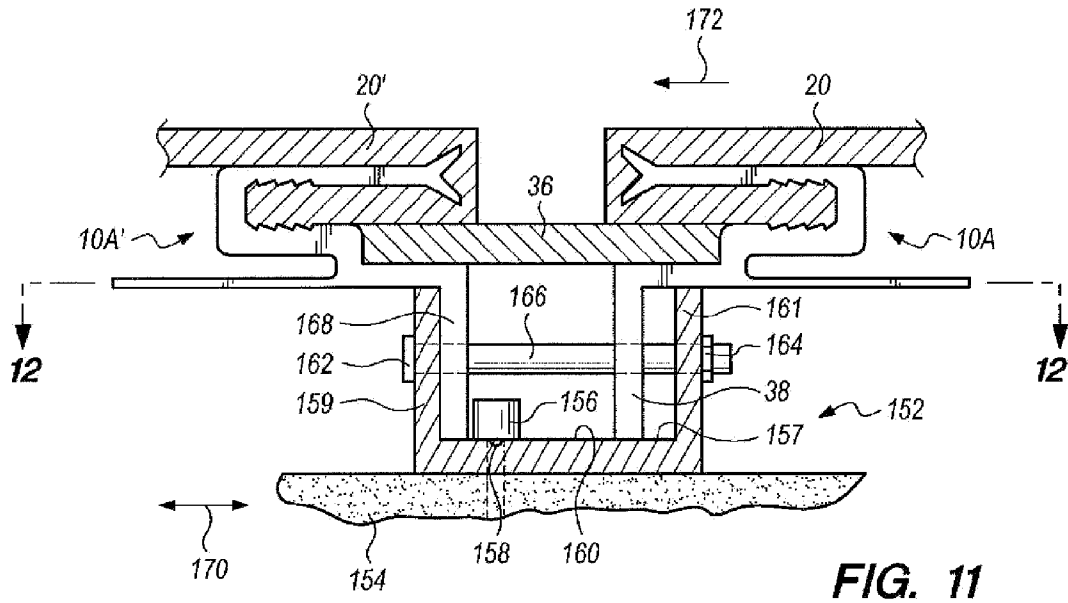

FIG. 10



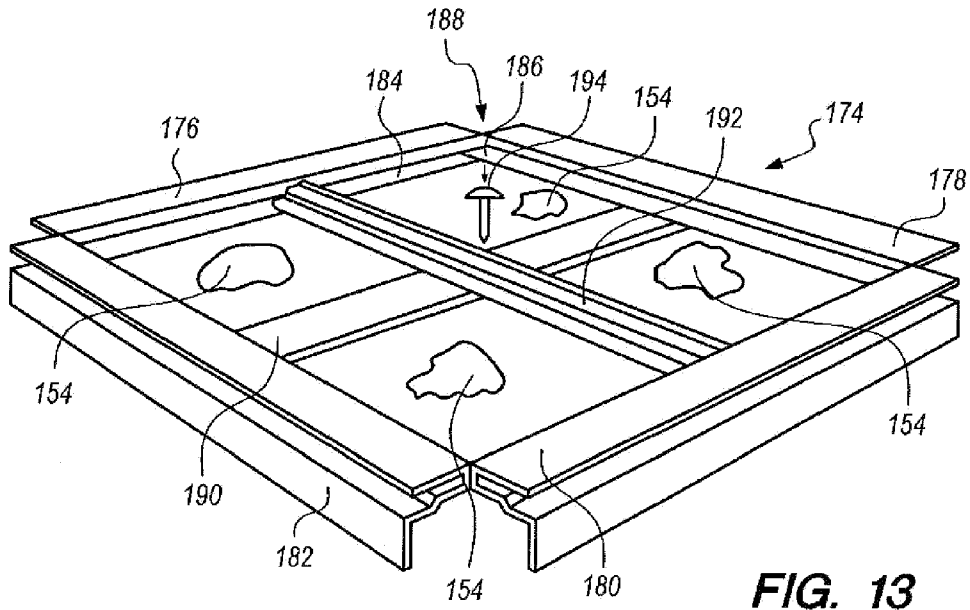

FIG. 13

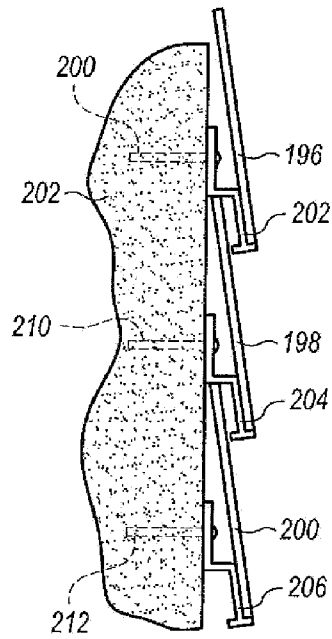

FIG. 14