



(12) **EUROPEAN PATENT APPLICATION**

(43) Date of publication:
11.01.2017 Bulletin 2017/02

(51) Int Cl.:
B65C 9/22 (2006.01)

(21) Application number: **15306138.7**

(22) Date of filing: **10.07.2015**

(84) Designated Contracting States:
AL AT BE BG CH CY CZ DE DK EE ES FI FR GB GR HR HU IE IS IT LI LT LU LV MC MK MT NL NO PL PT RO RS SE SI SK SM TR
 Designated Extension States:
BA ME
 Designated Validation States:
MA

(71) Applicant: **SIDEL PARTICIPATIONS**
76930 Octeville-sur-Mer (FR)

(72) Inventor: **FERRI, Marco**
43126 Parma (IT)

(74) Representative: **Siloret, Patrick et al**
Sidel Participations
Avenue de la Patrouille de France
76930 Octeville-sur-Mer (FR)

(54) **A LABEL APPLICATION APPARATUS AND METHOD**

(57) There is described a label application apparatus (1, 1', 1'') for applying labels (2) on respective articles (3); the apparatus (1, 1', 1'') comprises:

- first conveying means (8), to advance a succession of separate labels (2) along a first path (N) from a first input station (9) to a label application station (10), at which each of the labels (2) is applied on a respective article (3);
- second conveying means (11) to advance a succession of articles (3) along a second path (P) from a second

input station (12) to at least the label application station (10); and

- a glue applicator (15), which is arranged adjacent to the second conveying means (11) and is configured to spread in use a given pattern (G) of glue on a given area of each article (3) advancing along the second path (P) prior to reaching the label application station (10). [Figure 1]

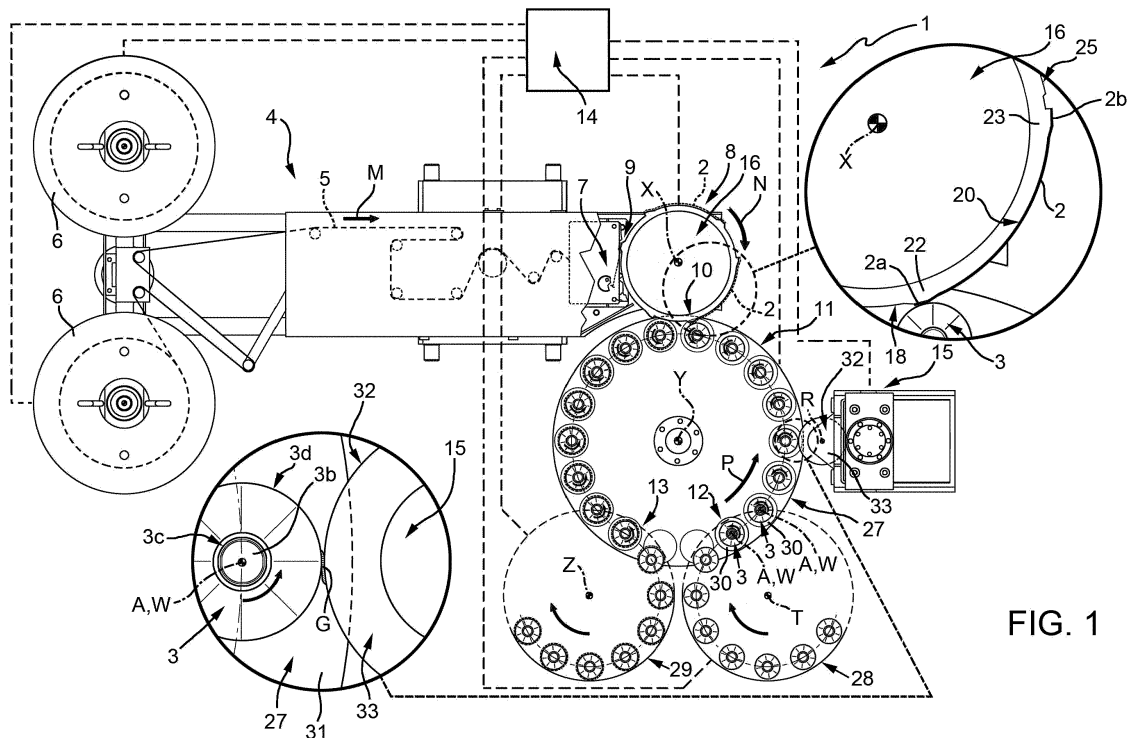

FIG. 1

Description

TECHNICAL FIELD

[0001] The present invention relates to a label application apparatus and method.

[0002] In particular, the present invention relates to an apparatus and a method for applying labels of the type cut off a roll of labelling material at appropriate lengths and then stuck, by means of melted glue, onto the outer surfaces of articles - in particular receptacles, such as bottles, pots, cans or the like - travelling along an article path.

BACKGROUND ART

[0003] As known, according to a widespread technique, labels are attached on the external surfaces of respective articles by means of melted glue previously spread on the back surfaces of the labels themselves.

[0004] In particular, labels are cut from a web at appropriate lengths and then advanced by a transfer drum towards a label application station, at which labels are applied onto the respective articles. Prior to reaching the label application station, each label receives a given amount of melted glue on its back surface by a glue applicator, such as a rotatable glue roller, cooperating tangentially with the transfer drum, or spray or injector systems; in practice, as it is advanced by the transfer drum, each label receives, on the opposite side thereof with respect to the transfer drum, the melted glue by the glue applicator.

[0005] Label application apparatuses and, more in general, labelling machines for automatically performing these operations are well known in the art and their use is widespread in the packaging industry.

[0006] In these machines, the articles are typically carried by a carousel along an article path so as to advance towards the label application station. At the same time, in the known label application apparatuses, a web of labelling material is fed from a roll-feeding unit to the outer lateral surface of the transfer drum, whereby said web is brought into contact with cutting means to be cut into labels of appropriate length.

[0007] In particular, the labels are retained by respective retaining regions of the outer lateral surface of the transfer drum; these retaining regions are equally spaced angularly around the axis of the transfer drum and are separated from each other by respective transition regions, along which labels fed from the roll-feeding unit slide prior to reaching the respective retaining regions.

[0008] Subsequently, glue is spread by the glue applicator on the labels as they are borne by the retaining regions of the outer lateral surface of the transfer drum. Glued labels are finally transferred from the transfer drum to the articles.

[0009] For proper performance of these operations, accurate handling of the labels is pursued through reten-

tion thereof on the outer lateral surface of the transfer drum, i.e. by applying suction or vacuum on the labels in a controlled manner. To this purpose, the outer lateral surface of the transfer drum comprises a plurality of orifices that can be fluidically connected with a suction source.

[0010] During spread of melted glue on the labels, especially when such application is performed by cooperation of the transfer drum with a rotatable glue roller, airborne glue particles may contaminate the transition regions of the outer lateral surface of the transfer drum. This type of contamination may cause failure of the labelling process as friction and drag may hamper slipping of the labels on the transfer drum during feeding from the roll-feeding unit and also may cause distortion and/or breakage of the labels themselves.

[0011] In addition, the operation of spreading the melted glue on the labels must be carried out in a very precise manner so as to prevent the glue from dirtying the bottles in the areas around the labels.

DISCLOSURE OF INVENTION

[0012] It is therefore an object of the present invention to provide a label application apparatus, which is designed to overcome, in a straightforward and low-cost manner, the aforementioned drawbacks.

[0013] According to the present invention, there is provided a label application apparatus as claimed in claim 1.

[0014] The present invention also relates to a label application method as claimed in claim 10.

BRIEF DESCRIPTION OF THE DRAWINGS

[0015] Three non-limiting embodiments of the present invention will be described by way of example with reference to the accompanying drawings, in which:

Figure 1 shows a top plan schematic view of a label application apparatus according to the present invention for applying a succession of labels onto the outer lateral surfaces of articles advancing along an article path;

Figure 2 shows a larger-scale top plan view, partly sectioned and with parts removed for clarity, of a label transfer drum of the Figure 1 apparatus during application of a label on a respective article;

Figure 3 shows a larger-scale detail of Figure 2;

Figures 4 and 5 are analogous to Figure 2 and show further steps of the application of the label on the respective article;

Figures 6 and 7 show perspective views of the article of Figures 2, 4 and 5 during application of the respective label;

Figure 8 shows a larger-scale detail of Figure 5 according to a possible variant in the way in which the label is applied on the respective article;

Figures 9 and 10 are analogous to respective Fig-

ures 6 and 7 and show the application of the label on the respective article according to the variant of Figure 8;

Figure 11 shows a top plan schematic view of a label application apparatus according to a different embodiment of the present invention; and

Figure 12 shows a top plan schematic view of a label application apparatus according to a further different embodiment of the present invention; and

Figure 13 is analogous to Figure 8 and shows a larger-scale detail of the Figure 12 apparatus.

BEST MODES FOR CARRYING OUT THE INVENTION

[0016] Number 1 in Figure 1 indicates as a whole a label application apparatus according to the present invention.

[0017] Apparatus 1 is adapted to be used for handling, transferring and applying labels 2 to respective articles 3 or, more specifically, receptacles, such as bottles, as said articles 3 are advanced along a path P.

[0018] As may be seen in detail in Figures 1 to 7, each article 3 is defined in the example shown by a bottle having a longitudinal axis A, a base 3a and a removable cap 3b, which is applied on an open neck 3c of the bottle itself and defines an end of the latter opposite the base 3a.

[0019] Apparatus 1 comprises:

- a web supplying unit 4, known per se and not further described, to unwind a web 5 of labelling material off a reel 6 and to progressively advance it along a path M;
- a cutting unit 7, also known per se and not further described, arranged at the end of path M and adapted to cut the web 5 into individual labels 2, usually of substantially square or rectangular profile, of the desired sizes;
- first conveying means 8 to receive the separate labels 2 from cutting unit 7 at an input station 9 and to advance such labels 2 in succession along a path N from the input station 9 itself to a label application station 10, at which each of the labels 2 is applied on a respective article 3 in a tubular form;
- second conveying means 11 to advance a succession of articles 3 along path P from an input station 12 to an output station 13 passing through the label application station 10;
- a glue applicator 15 for supplying melted glue to attach each label 2 to a respective article 3; and
- a control unit 14, only schematically shown in Figure 1, to control operation of web supplying unit 4, cutting unit 7, first and second conveying means 8, 11 and glue applicator 15.

[0020] As explained in greater details later on, articles 3 are advanced in vertical positions along path P, i.e. with their axes A vertically oriented and orthogonal to the path

P itself; the same applies to the web 5 and the labels 2, which are in turn advanced along the respective paths M, N in vertical positions, i.e. parallel to the axes A of the articles 3, so that the labels 2 themselves can be applied on outer lateral surfaces 3d of the respective articles 3.

[0021] All paths M, N and P lay horizontally; path M is also parallel to the longitudinal size of the web 5.

[0022] With particular reference to Figures 1 to 5, in the example shown, first conveying means 8 comprise a substantially cylindrical label transfer drum 16 having a vertical central axis X, orthogonal to the plane on which path N lays; transfer drum 16 is configured to retain the labels 2 on its outer lateral surface 18 by suction and to rotate about the axis X to transfer each label 2 from input station 9 to label application station 10 along path N.

[0023] As clearly visible in Figures 1 to 5, label path N is tangential to article path P at the label application station 10. In addition, label application station 10 is arranged at a given angular distance from the input station 9 about the axis X of rotation of transfer drum 16.

[0024] Outer lateral surface 18 of transfer drum 16 comprises one or more label retaining regions 20, three in the example shown, provided with a plurality of through holes (not visible) selectively communicating in a known manner with a suction or vacuum source (known per se and not shown) through internal passages (not visible) of the transfer drum 16 itself. In practice, these internal passages can be connected to the suction or vacuum source by means of suitable orifices or manifolds present on a non-rotating base (known per se and not shown) on which the transfer drum 16 is supported and rotated.

[0025] Retaining regions 20 are adapted to retain the respective labels 2 during transfer thereof from input station 9 to label application station 10.

[0026] It is evident that a different number of retaining regions 20 can be provided on the outer lateral surface 18 of transfer drum 16, depending on the capacity of the apparatus 1 and on the length of the labels 2.

[0027] As shown in details in Figures 1 and 2, each retaining region 20 presents, at its opposite circumferential ends, respective interaction zones 22, 23 designed to engage or interact, in use, with a leading end portion 2a and a trailing end portion 2b of a relative label 2, respectively.

[0028] In particular, the interaction zone 22 defines a front or downstream interaction zone of the relative retaining region 20, whilst the interaction zone 23 defines a back or upstream interaction zone 23 of the retaining region 20 itself with reference to path N, in the sense that the interaction zone 22 comes before the interaction zone 23 by proceeding along the path N itself.

[0029] In the specific embodiment shown in Figures 1 to 5 and 8, these interaction zones 22, 23 are slightly protruding from the outer lateral surface 18.

[0030] As a possible alternative not shown, the interaction zones 22, 23 may be also part of a respective continuous arc-shaped retaining region 20, having a centre different and spaced from axis X of transfer drum 16;

in this way, transfer drum 16 has an approximately cylindrical, lobed configuration.

[0031] In order to retain the labels 2 on the transfer drum 16, the interaction zones 22, 23 also present a plurality of through holes (not visible) selectively communicating with the suction or vacuum source.

[0032] In practice, during transfer of one label 2 from the cutting unit 7 to the transfer drum 16, progressive slide-back of the label 2 itself ensures that the label position at the point of cut corresponds to a specific position whereat the leading end portion 2a of the label 2 is positioned on the front interaction zone 22 and the trailing end portion 2b of the label 2 is positioned on the back interaction zone 23.

[0033] At the interaction zones 22, 23 the label transfer occurs from the relative retaining region 20 to the corresponding article 3.

[0034] Retaining regions 20 of outer lateral surface 18 are equally spaced angularly around axis X of transfer drum 16 and are separated from each other by respective transition regions 25, on which labels 2 fed from cutting unit 7 slide prior to reaching the respective retaining regions 20.

[0035] In practice, by considering the direction of rotation of transfer drum 16 (which direction is indicated in Figures 2, 4 and 5 by the hatched arrow and is clockwise), each transition region 25 extends between the back interaction zone 23 of a downstream retaining region 20 and the front interaction zone 22 of an upstream retaining region 20 and is provided with through holes (not visible), also selectively connectable with the suction or vacuum source.

[0036] In the embodiment illustrated in Figures 1 to 5, three transition regions 25 are present on the transfer drum 16, which are equally spaced angularly from one another about the axis X.

[0037] In other words, considering the direction of rotation of the transfer drum 16, each retaining region 20 extends from the rear edge of a back interaction zone 23 to the front edge of a relative front interaction zone 22, whilst the corresponding transition region 25 extends from this front interaction zone 22 to the next interaction zone 23.

[0038] As commented above with reference to the retaining regions 20, also the overall number of transition regions 25 provided in the outer lateral surface 18 of the transfer drum 16 can vary accordingly, depending on the capacity of the apparatus 1 and, even more so, on the length of the labels 2 to be processed, the minimum number being one.

[0039] As visible in the example of Figures 1 to 5, each transition region 25 has a smaller angular extension or width around axis X than the angular extension or width of the relative retaining region 20 and, in use, can serve the purpose of starting to attract the relative label 2 at input station 9, so that such label 2 is then received on the retaining region 20 directly upstream and on the relative interaction zones 22, 23.

[0040] According to possible alternative solutions, each transition region 25 may also have the same angular extension around axis X as the relative retaining region 20 or even a larger angular extension than that of such retaining region 20, depending on the lengths of the labels 2 to be applied on the articles 3.

[0041] The transfer drum 16 works conventionally by rotating in the direction indicated by the hatched arrow in Figures 2, 4 and 5, so that it first receives, substantially at the input station 9, the web 5 of labelling material, which is then cut to obtain a label 2 of the desired length.

[0042] With reference to Figure 1, conveying means 11 comprise a carousel 27 rotating about an axis Y, parallel to axis X, to transfer the articles 3 along path P.

[0043] More specifically, carousel 27 receives a sequence of articles 3 to be labelled by an inlet star wheel 28, which cooperates with carousel 27 at input station 12 and is mounted to rotate about a longitudinal axis T parallel to axes X, Y.

[0044] Carousel 27 releases a sequence of labelled articles 3 to an outlet star wheel 29, which cooperates with carousel 27 at output station 13 and is mounted to rotate about a longitudinal axis Z parallel to axes X, Y, T.

[0045] Carousel 27 comprises a plurality of support plates 30, which are equally spaced about rotation axis Y, are mounted along a peripheral edge 31 of the carousel 27 itself and are moved by the latter along an annular path. The article path P is defined by an arc-shaped portion of the annular path of the plates 30; as a matter of fact, path P starts from input station 12 and ends at output station 13, both stations being arranged along the annular path of the plates 30.

[0046] Each support plate 30 is rotatable about a respective axis W, parallel to the axis Y of the carousel 27. In particular, each support plate 30 is configured to support the relative article 3 in a vertical position with its axis A coaxial to the axis W of the support plate 30 itself; in this way, rotation of each support plate 30 about its axis W produces a corresponding rotation of the supported article 3 about the relative axis A.

[0047] Rotation of each support plate 30 is activated at label application station 10 by control unit 14 so as to rotate the relative article 3 about its axis A and to produce wrapping of the relative label 2, fed by transfer drum 16, on the outer lateral surface 3d of the article 3 itself up to take a tubular form.

[0048] With reference to Figure 1, glue applicator 15 is advantageously arranged adjacent to carousel 27 and between input station 12 and label application station 10 with reference to path P and is configured to spread in use a given pattern (Figures 1, 3, 5, 6, 8 and 9) of melted glue on a given area of each article 3 advancing along the path P itself.

[0049] In particular, glue applicator 15 comprises glue feeding means 32 configured to apply at least one strip G of glue on the outer lateral surface 3d of each article 3, parallel to the longitudinal axis A of the article 3 itself and to the axes X, Y, T, Z and W.

[0050] In the example shown in Figure 1, glue feeding means 32 preferably comprise a glue roller 33 having an axis R parallel to axes X, Y, T, Z and W and cooperating tangentially with the outer lateral surface 3d of each article 3.

[0051] More specifically, glue roller 33 is mounted to rotate about its axis R and has an outer lateral surface covered by melted glue and cooperating tangentially with the articles 3 advanced along path P. In practice, as it is advanced by carousel 27, each article 3 contacts, on its outer lateral surface 3d, the glue roller 33 to be spread with the strip G of melted glue. In other words, a predetermined glue strip G is applied by the glue roller 33 onto the area of the outer lateral surface 3d of each article 3 where wrapping of the relative label 2 starts and ends (Figures 3, 5 and 8).

[0052] In use, labels 2 are progressively separated from web 5 of labelling material by cutting unit 7 and then fed, one after the other, to transfer drum 16. Here, labels 2 are rotated by the transfer drum 16 along path N from input station 9 to label application station 10.

[0053] During transfer from the cutting unit 7 to the transfer drum 16, the labelling material forming each label 2 slides along a relative transition region 25 prior to reaching the subsequent retaining region 20.

[0054] Along path N, each label 2 is supported by transfer drum 16 along the side destined to define the front surface when the label 2 itself is applied onto the respective article 3.

[0055] In the meantime, articles 3 are fed, one after the other, to respective support plates 30 of carousel 27 by input star wheel 28 at input station 12 and are advanced along path P by the carousel 27 itself towards label application station 10.

[0056] During rotation of carousel 27 about axis Y, each article 3 interacts with glue roller 33 for retaining from the latter a strip G of melted glue on the area of its outer lateral surface 3d destined to receive the leading and trailing end portions 2a, 2b of a relative label 2.

[0057] Glue roller 33 also rotates about its axis R in a direction opposite the one of carousel 27 about axis Y.

[0058] The strip G of melted glue spread by glue roller 33 on the outer lateral surface 3d of each article 3 has the same height as the respective label 2 to be applied on such article 3.

[0059] At label application station 10 (Figures 2, 3 and 6), the leading end portion 2a of one label 2 adheres to a longitudinal region G1 of strip G of glue provided on the respective article 3, namely the one defining the upstream end region of such strip G with reference to the direction of rotation of the article 3 itself about its axis A (counterclockwise direction in Figure 2).

[0060] Further rotation of the article 3 about axis A, produced by a corresponding rotation of the relative support plate 30 about its axis W, produces complete wrapping of the label 2 on the outer lateral surface 3d of the article 3 itself (Figure 4).

[0061] The rotation of the article 3 ends when the trail-

ing end portion 2b of the respective label 2 adheres to the remaining longitudinal region G2 of the strip G of glue (Figures 5 and 7).

[0062] As visible in Figures 3 and 5, longitudinal regions G1 and G2 of the strip G of glue are placed laterally adjacent to one another.

[0063] In the example shown in Figures 2 to 7, no overlap occurs between leading end portion 2a and trailing end portion 2b of each label 2 applied on the respective article 3; in other words, leading end portion 2a and trailing end portion 2b of each label 2 cooperate head-to-head with one another.

[0064] In the alternative embodiment of Figures 8 to 10, the trailing end portion 2b of each label 2 slightly overlaps the leading end portion 2a.

[0065] After application of the labels 2, the articles 3 are advanced by carousel 27 towards the output station 13, where they are released to the output star wheel 29.

[0066] Number 1' in Figure 11 indicates as a whole a different embodiment of a label application apparatus according to the present invention; apparatuses 1 and 1' being similar to one another, the following description is limited to the difference between them, and using the same references, where possible, for identical or corresponding parts.

[0067] In particular, apparatus 1' differs from apparatus 1 in that glue feeding means 32 of glue applicator 15 comprise a spraying or an injecting unit 34 adapted to spread a strip G of melted glue on the outer lateral surface 3d of each article 3.

[0068] The operation of apparatus 1' is completely analogous to that of apparatus 1 and is not repeated for the sake of conciseness.

[0069] Number 1" in Figure 12 indicates as a whole a further different embodiment of a label application apparatus according to the present invention; apparatuses 1" and 1' being similar to one another, the following description is limited to the difference between them, and using the same references, where possible, for identical or corresponding parts.

[0070] In particular, apparatus 1" differs from apparatus 1' by comprising a further glue applicator 35 arranged adjacent to transfer drum 16 and between input station 9 and label application station 10 with reference to path N; control unit 14 is configured to selectively activate glue applicator 35 each time that back interaction zone 23 passes by the glue applicator 35 itself so as to apply a given pattern of melted glue, a further strip H, on the trailing end portion 2b of the relative label 2 engaging such back interaction zone 23 and to allow, during wrapping of each label 2 on the respective article 3, that the trailing end portion 2b overlaps the leading end portion 2a of the same label 2 and adheres thereto (Figure 13).

[0071] As visible in Figure 12, glue applicator 35 preferably comprises a spraying or an injecting unit 36 similar to spraying or injecting unit 34 and adapted to spread a strip H of melted glue on the trailing end portion 2b of each label 2; strip H is parallel to strip G; in addition, strip

G is preferably wider than strip H.

[0072] As a possible alternative not shown, glue applicator 35 may also comprise a glue roller, similar to glue roller 33 and having, on its outer lateral surface, at least one projecting rib covered with melted glue and driven by control unit 14 to contact each label 2 advanced by transfer drum 16 at each back interaction zone 23 - which in this case may be defined by a back pad with a damping action - in order to apply the glue only on the trailing end portion 2b of each label 2.

[0073] The operation of apparatus 1" differs from the ones of apparatuses 1, 1' only in that the trailing end portion 2b of each label 2 receives a strip H of melted glue while the label 2 itself advances along path N from input station 9 to label application station 10.

[0074] In this case, as shown in Figure 13, a further layer of glue, represented by the strip H, is interposed between the overlapped leading and trailing end portions 2a, 2b of each label 2.

[0075] The advantages that the label application apparatuses 1, 1', 1" and method according to the present invention allow to achieve are clear from the foregoing description.

[0076] In particular, in both apparatuses 1, 1', thanks to the fact that the melted glue is applied on the articles 3 only and not on the labels 2, it is completely avoided any risk to contaminate the transfer drum 16 with filaments and deposits of glue, which may hinder the slipping of the labels 2 during feeding to the transfer drum 16 and which may require to stop production in order to clean the transfer drum 16 itself.

[0077] In addition, in the apparatus 1, the construction of the transfer drum 16 is easier than in the prior art, as such transfer drum 16 does not need to be provided with damping pads to allow the leading and trailing end portions 2a, 2b of each label 2 to cooperate with glue roller 33.

[0078] In the apparatus 1", the possible contamination of the transfer drum 16 is limited with respect to the prior art solutions, as the melted glue is only applied on the trailing end portion 2b of each label 2 and not to the opposite end portions thereof.

[0079] In addition, it is not necessary to be extremely precise in the application of the glue on the articles - for instance, the strip G may even be larger than expected - as the labels 2 are then often destined to cover the articles areas of application of the glue.

[0080] Last but not least, since the glue is applied on the articles 3, the overlap of the leading and trailing end portion 2a, 2b of each label 2 is no more necessary to fix the label 2 itself on the respective article 3 and therefore can be taken at the minimum or may even be completely absent. As a matter of fact, in the solutions according to the present invention, the fixing action of each label 2 on the respective article 3 is performed by the strip G of glue on the article 3 itself. It is therefore possible to achieve consistent savings of labeling material by considering the extremely high number of labels 2 applied on the articles

3 during production.

[0081] Clearly, changes may be made to label application apparatuses 1, 1', 1" and to the method as described and illustrated herein without, however, departing from the scope of protection as defined in the accompanying claims.

Claims

1. A label application apparatus (1, 1', 1") for applying labels (2) on respective articles (3), said apparatus (1, 1', 1") comprising:

- first conveying means (8) to advance a succession of separate labels (2) along a first path (N) from a first input station (9) to a label application station (10), at which each of said labels (2) is applied on a respective article (3);
- second conveying means (11) to advance a succession of articles (3) along a second path (P) from a second input station (12) to at least said label application station (10);
- a glue applicator (15) supplying glue to attach each label (2) to a respective article (3);

characterized in that said glue applicator (15) is arranged adjacent to said second conveying means (11) and between said second input station (12) and said label application station (10) with reference to said second path (P), and **in that** said glue applicator (15) is configured to spread in use a given pattern (G) of glue on a given area of each article (3) advancing along said second path (P).

2. The apparatus as claimed in claim 1, wherein said first conveying means (8) comprise a transfer drum (16) having a central axis (X) orthogonal to said first path (N); and wherein said transfer drum (16) is configured to retain each label (2) on its outer lateral surface (18) by suction and rotates about its central axis (X) to transfer each of said labels (2) from the first input station (9) to the label application station (10) along said first path (N).
3. The apparatus as claimed in claim 2, wherein said second path (P) is tangential to said first path (N) at said label application station (10).
4. The apparatus as claimed in claim 2 or 3 for articles (3) having longitudinal axes (A) and receiving the respective labels (2) on outer lateral surfaces (3d) extending around the said longitudinal axes (A), wherein said second conveying means (11) support said articles (3) with their longitudinal axes (A) parallel to the central axis (X) of said transfer drum (16).
5. The apparatus as claimed in claim 4, wherein said

- glue applicator (15) comprises glue feeding means (32) configured to apply at least one strip (G) of glue on the outer lateral surface (3d) of each article (3), parallel to the longitudinal axis (A) of the article (3) itself and to the central axis (X) of said transfer drum (16). 5
6. The apparatus as claimed in claim 4 or 5, wherein said second conveying means (11) comprise rotating means (30) selectively activated to rotate each article (3) about its longitudinal axis (A) at said label application station (10) so as to produce wrapping of the relative label (2), fed by said first conveying means (8), on the outer lateral surface (3d) of the article (3) itself. 10
7. The apparatus as claimed in claim 6, wherein said glue feeding means (32) are configured to apply in use said strip (G) of glue on each article (3) at the area thereof where wrapping of the relative label (2) starts and ends. 20
8. The apparatus as claimed in any one of claims 2 to 7, wherein the outer lateral surface (18) of the transfer drum (16) comprises at least a front interaction zone (22) and a back interaction zone (23) angularly spaced apart and engaging in use respectively with a leading end portion (2a) and a trailing end portion (2b) of a relative label (2) advanced along said first path (N). 25
9. The apparatus as claimed in claim 8, also comprising a further glue applicator (35) arranged adjacent to said first conveying means (8) and between said first input station (9) and said label application station (10) with reference to said first path (N); said further glue applicator (35) being configured to apply a given pattern of glue on the trailing end portion (2b) of each label (2) engaging a relative back interaction zone (23) so as to allow, during wrapping of said label (2) on the respective article (3), that said trailing end portion (2b) overlaps the leading end portion (2) of the same label (2) and adheres thereto. 30
10. A label application method for applying labels (2) on respective articles (3), said method comprising the steps of: 35
- advancing a succession of separate labels (2) along a first path (N) from a first input station (9) to a label application station (10); 40
 - advancing a succession of articles (3) along a second path (P) from a second input station (12) to at least said label application station (10);
 - supplying glue to attach each label (2) to a respective article (3); and 45
 - applying each label (2) on a respective article (3) at said label application station (10);
- characterized in that** said step of supplying glue comprises the step of spreading a given pattern (G) of glue on a given area of each article (3) advancing along said second path (P).
11. The method as claimed in claim 10 for articles (3) having longitudinal axes (A) and receiving the respective labels (2) on outer lateral surfaces (3d) extending around said longitudinal axes (3d), wherein the pattern of glue applied on each article (3) is a strip (G) parallel to the longitudinal axis (A) of the article (3) itself. 50
12. The method as claimed in claim 11, wherein said step of applying comprises the step of wrapping each label (2) on the outer lateral surface (3d) of the respective article (3). 55
13. The method as claimed in claim 12, wherein said strip (G) of glue is applied on each article (3) at the area thereof where wrapping of the relative label (2) starts and ends.
14. The method as claimed in claim 12 or 13, wherein, during wrapping of each label (2) on the relative article (3), a leading end portion (2a) of the label (2) is made to adhere to one longitudinal portion (G1) of said strip (G) and a trailing end portion (2b) of said label (2) is made to adhere to a second longitudinal portion (G2) of said strip (G) placed laterally adjacent to said first longitudinal portion (G1).
15. The method as claimed in claim 14, wherein the trailing end portion (2b) of each label (2) overlaps at least in part the leading end portion (2a) of the same label (2).
16. The method as claimed in claim 15, further comprising the step of spreading a given pattern (I) of glue on the trailing end portion (2b) of each label (2) while advancing along said first path (N), so as to make adhere the overlapped trailing and leading end portion (2b, 2a) of each label (2) at the end of the step of wrapping.

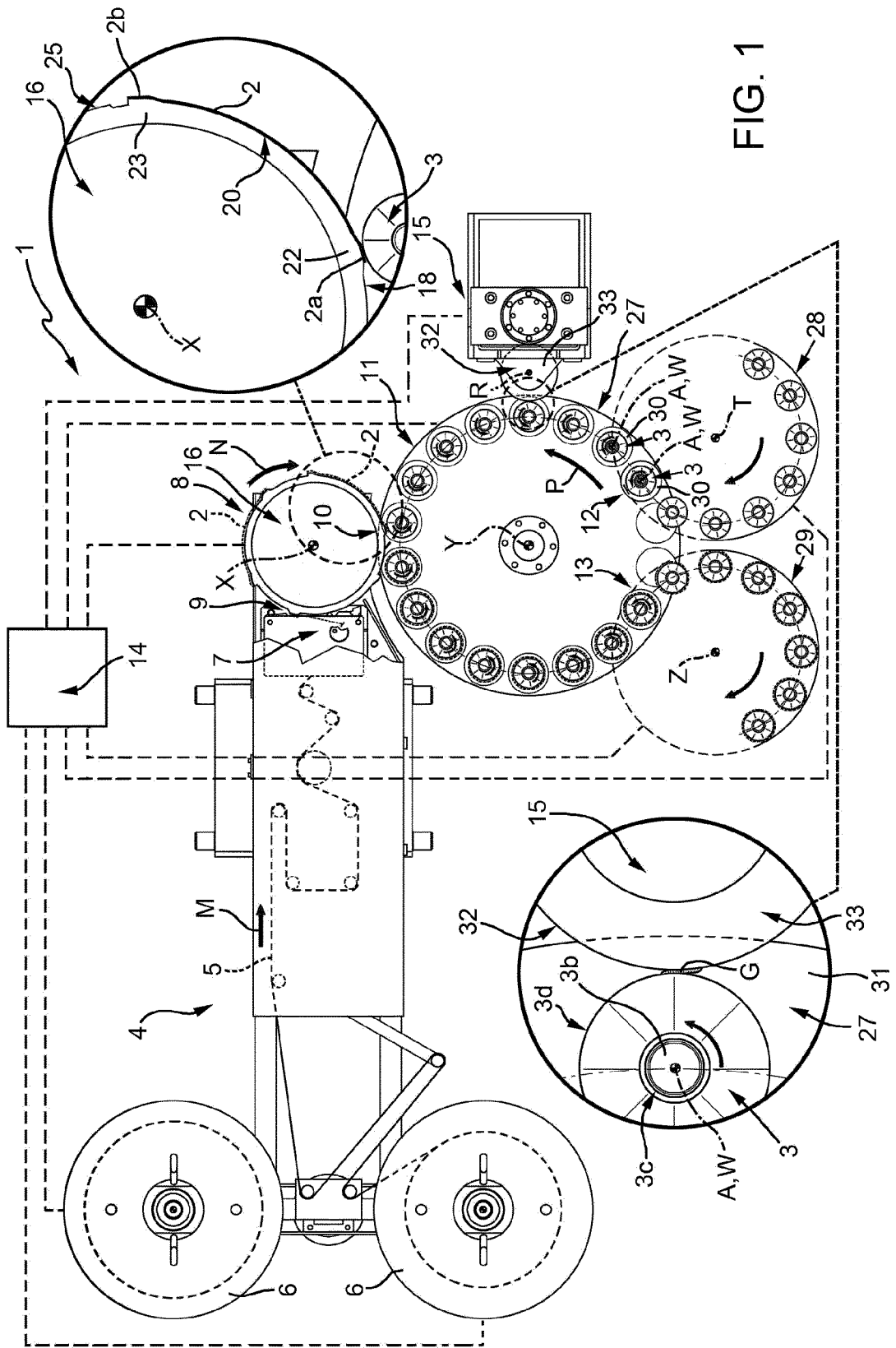

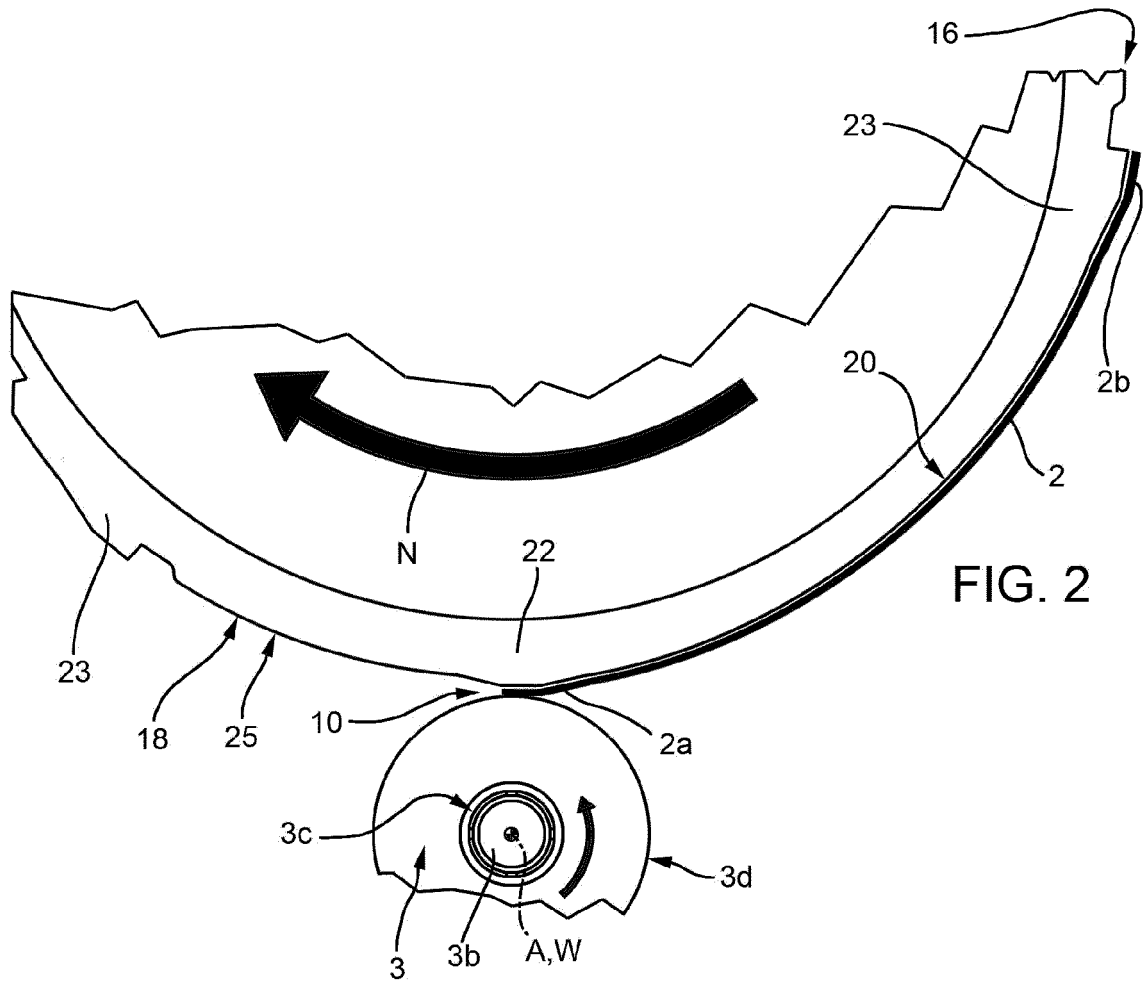

FIG. 2

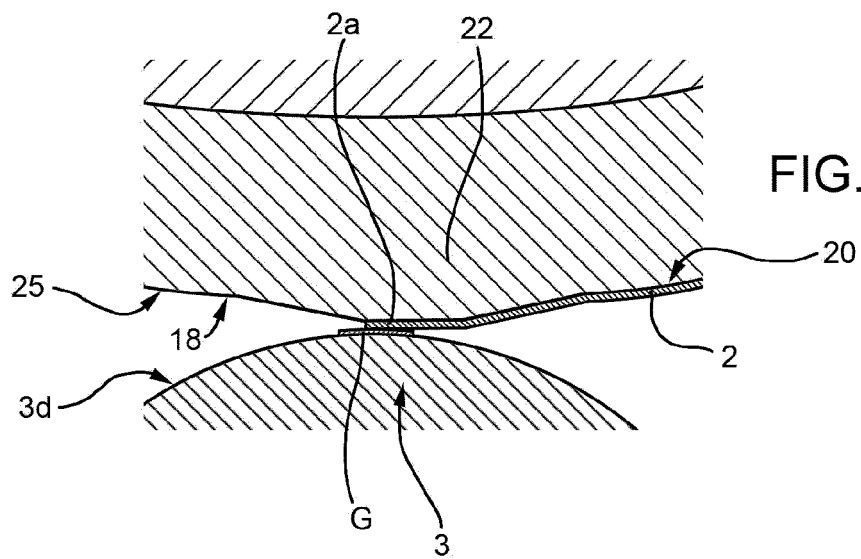

FIG. 3

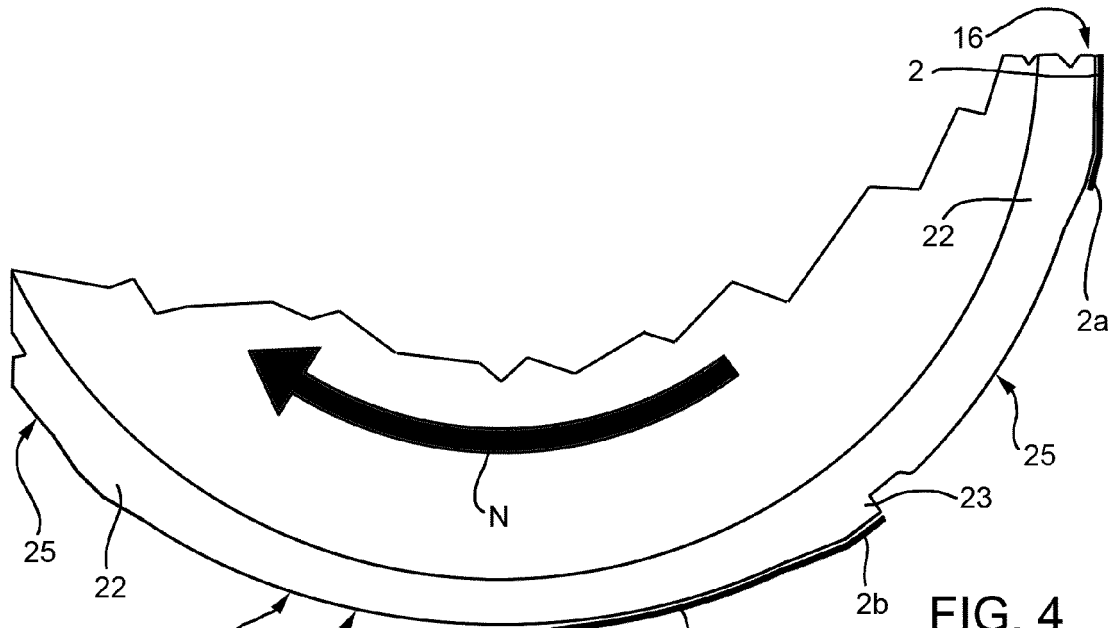

FIG. 4

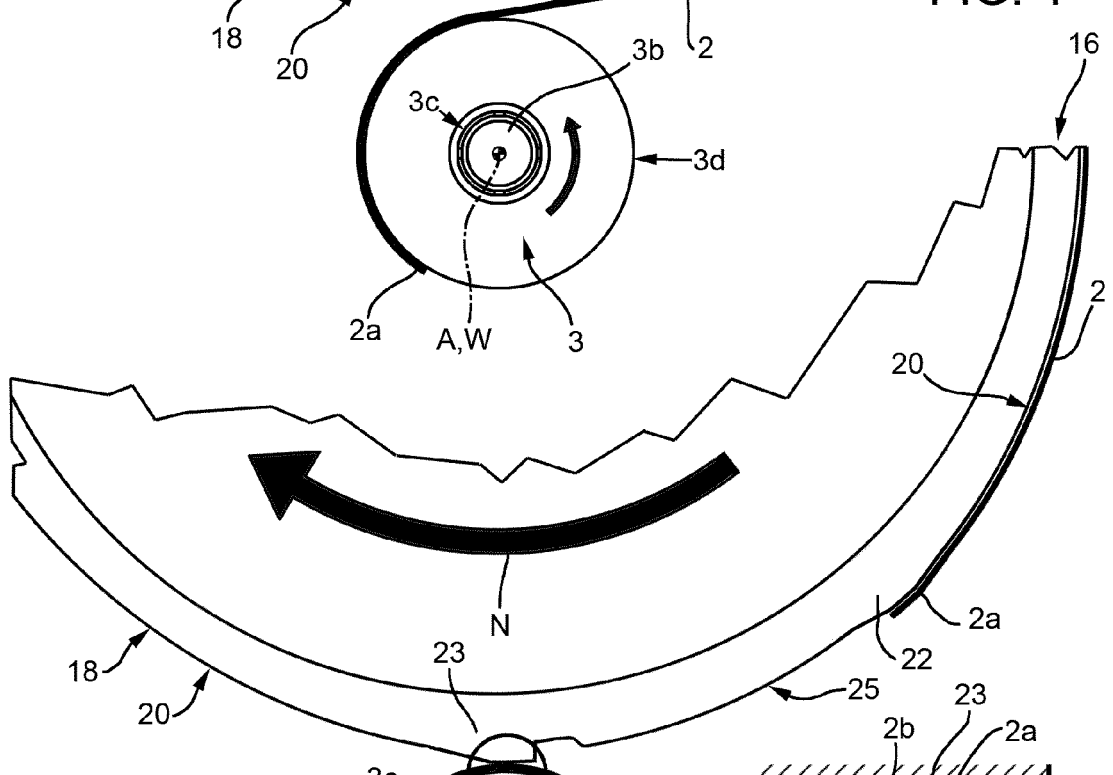
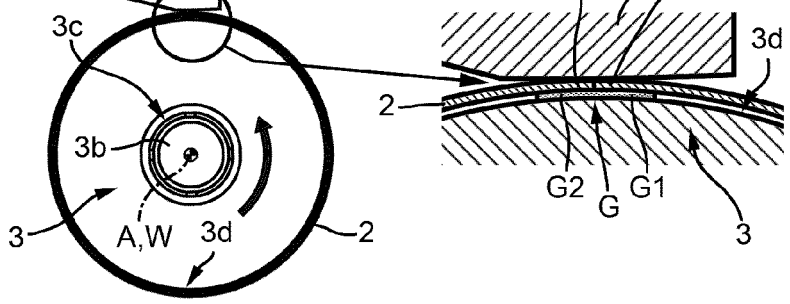

FIG. 5



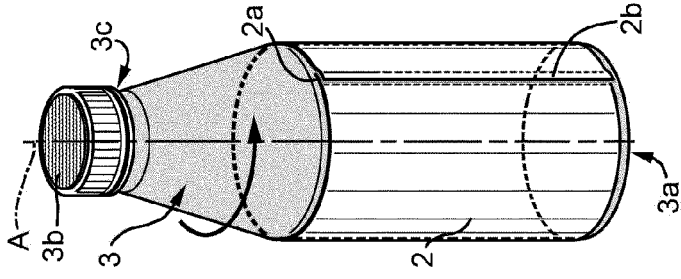

FIG. 10

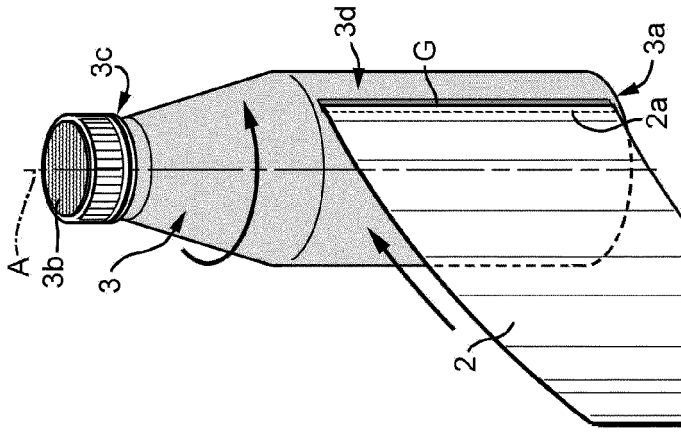

FIG. 9

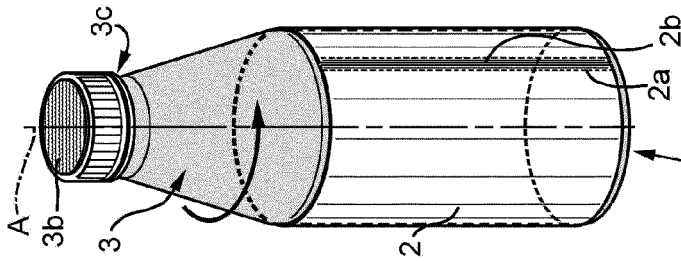

FIG. 7

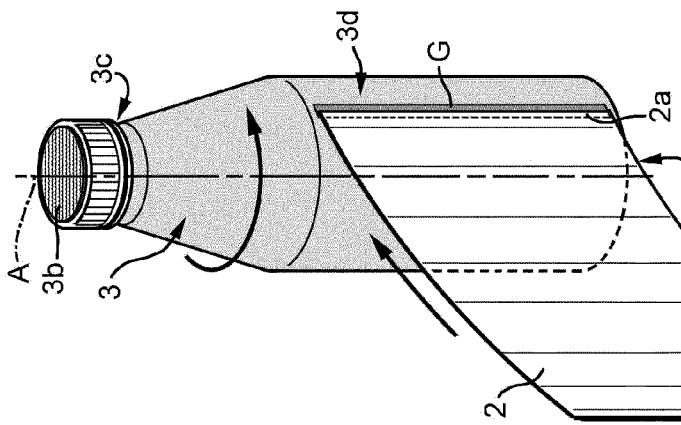

FIG. 6

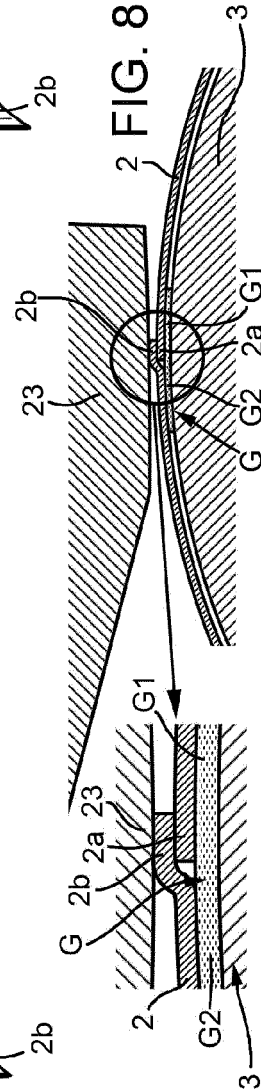
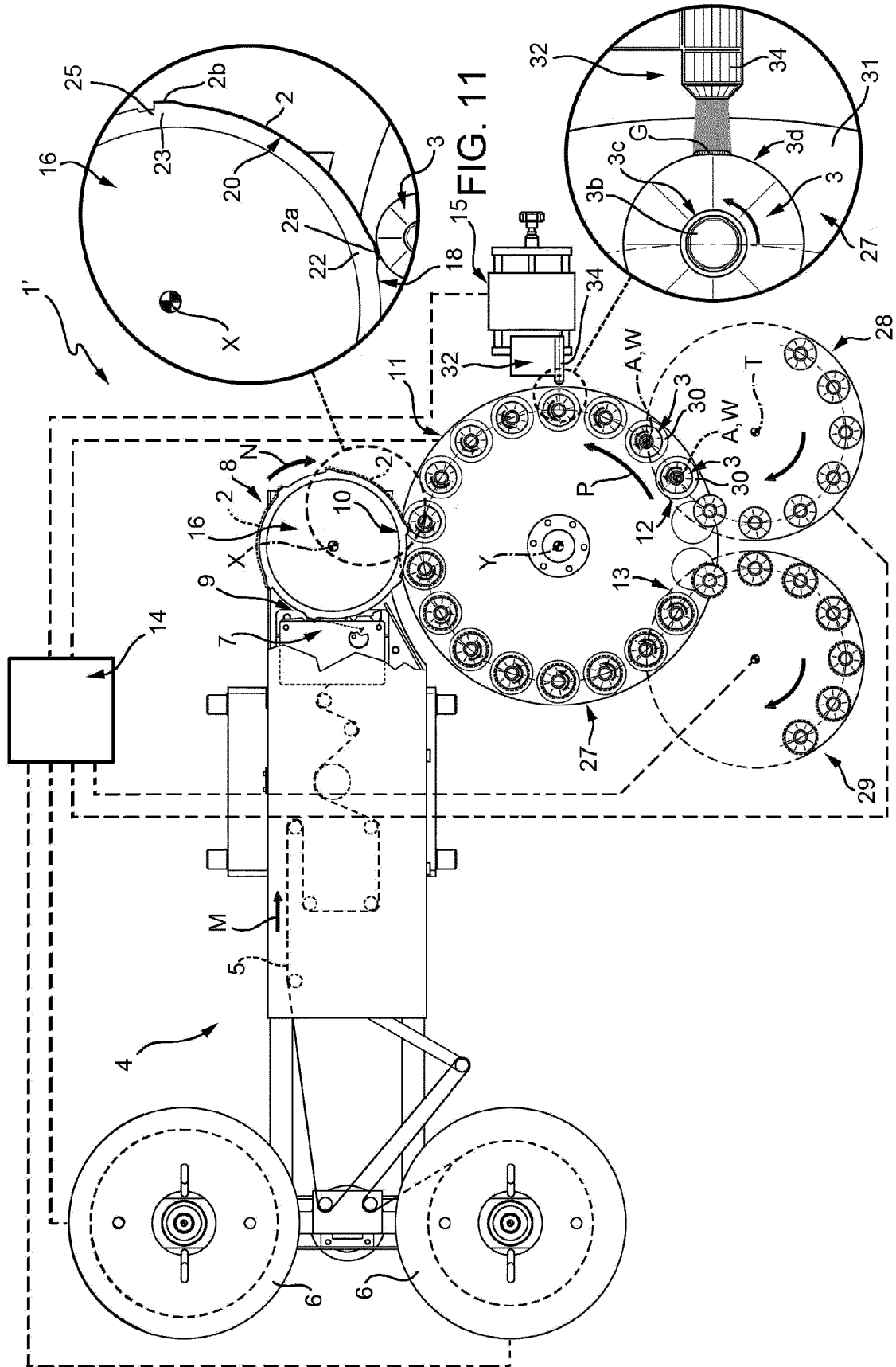
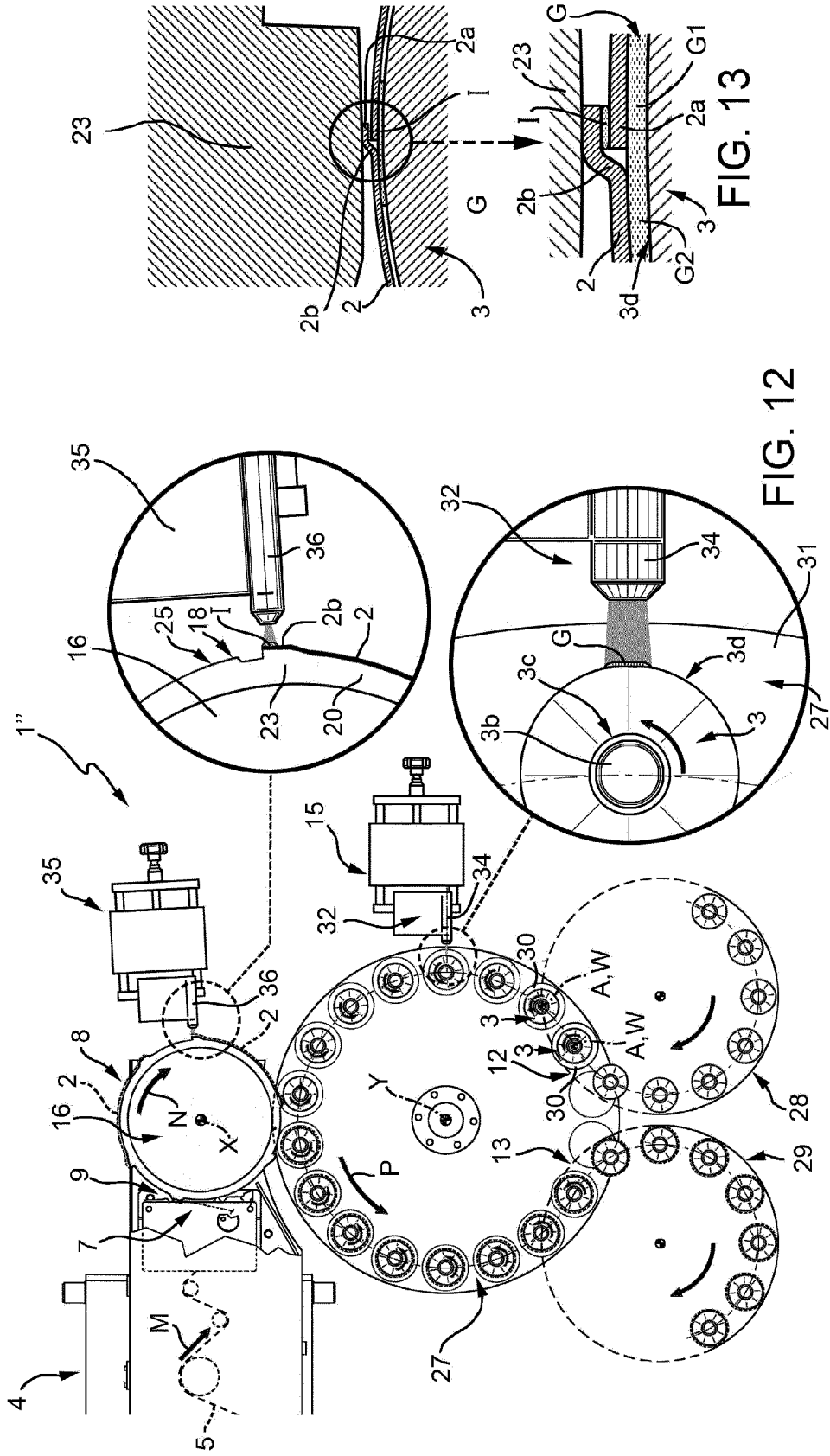

FIG. 8







EUROPEAN SEARCH REPORT

Application Number
EP 15 30 6138

5

10

15

20

25

30

35

40

45

50

55

DOCUMENTS CONSIDERED TO BE RELEVANT			
Category	Citation of document with indication, where appropriate, of relevant passages	Relevant to claim	CLASSIFICATION OF THE APPLICATION (IPC)
X	WO 2007/005396 A1 (NORDSON CORP [US]; FORT WESLEY C [US]; VARGA LESLIE J [US]; LINGIER ER) 11 January 2007 (2007-01-11)	1-13	INV. B65C9/22
A	* paragraph [0046]; figure 8 *	14-16	
X	DE 196 30 690 A1 (KRONSEDER MASCHF KRONES [DE]) 5 February 1998 (1998-02-05)	1-13	
A	* column 3, line 14 - line 28 * * column 3, line 47 - line 63 * * column 4, line 18 - line 34; figures 1-3 *	14-16	
X	DE 10 2005 058374 A1 (GERNEP GMBH [DE]) 14 June 2007 (2007-06-14)	1-13	
A	* paragraphs [0011] - [0015]; figures 1,2 *	14-16	
The present search report has been drawn up for all claims			TECHNICAL FIELDS SEARCHED (IPC)
			B65C
Place of search		Date of completion of the search	Examiner
The Hague		13 January 2016	Wartenhorst, Frank
CATEGORY OF CITED DOCUMENTS			
X : particularly relevant if taken alone Y : particularly relevant if combined with another document of the same category A : technological background O : non-written disclosure P : intermediate document		T : theory or principle underlying the invention E : earlier patent document, but published on, or after the filing date D : document cited in the application L : document cited for other reasons & : member of the same patent family, corresponding document	

EPO FORM 1503 03/02 (P04C01)

ANNEX TO THE EUROPEAN SEARCH REPORT
ON EUROPEAN PATENT APPLICATION NO.

EP 15 30 6138

5 This annex lists the patent family members relating to the patent documents cited in the above-mentioned European search report.
The members are as contained in the European Patent Office EDP file on
The European Patent Office is in no way liable for these particulars which are merely given for the purpose of information.

13-01-2016

Patent document cited in search report	Publication date	Patent family member(s)	Publication date
WO 2007005396 A1	11-01-2007	AT 518767 T	15-08-2011
		CN 101228072 A	23-07-2008
		DE 202006012400 U1	08-03-2007
		EP 1771340 A1	11-04-2007
		EP 2361836 A2	31-08-2011
		JP 5635233 B2	03-12-2014
		JP 2009500248 A	08-01-2009
		US 2007029036 A1	08-02-2007
		US 2008014344 A1	17-01-2008
		US 2010300599 A1	02-12-2010
WO 2007005396 A1	11-01-2007		
DE 19630690 A1	05-02-1998	BR 9706648 A	12-01-1999
		DE 19630690 A1	05-02-1998
		EP 0865386 A1	23-09-1998
		JP 2000500723 A	25-01-2000
		WO 9804470 A1	05-02-1998
DE 102005058374 A1	14-06-2007	NONE	