

G. MAHONEY & F. A. ROUNDS.

CULVERT.

APPLICATION FILED SEPT. 9, 1908.

928,265.

Patented July 20, 1909.

Fig. 1.

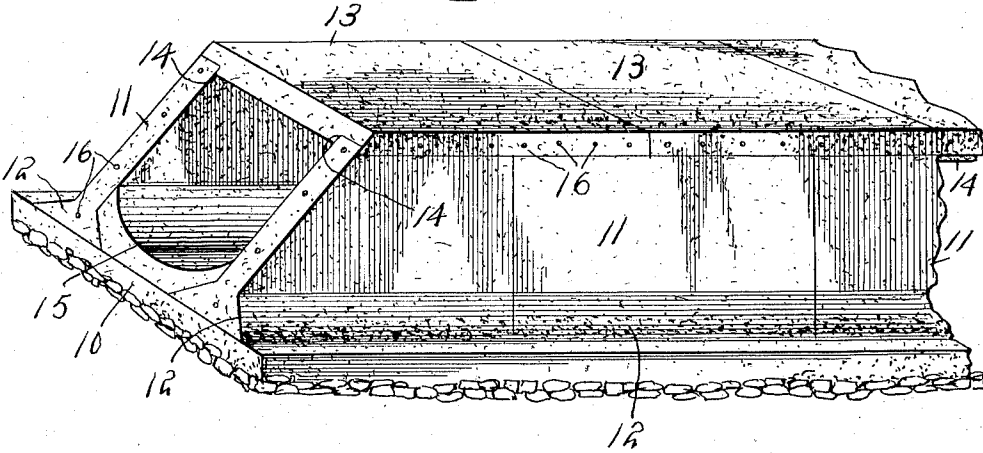

Fig. 2.

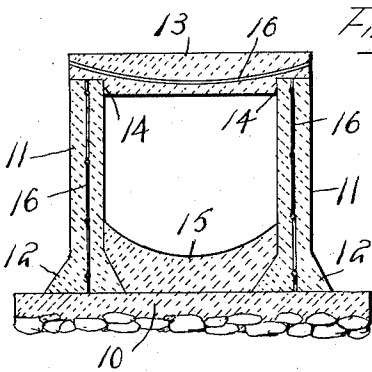

Fig. 4.

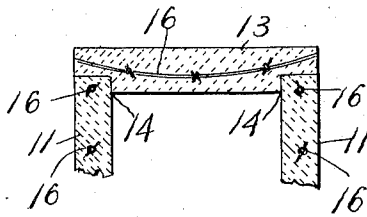
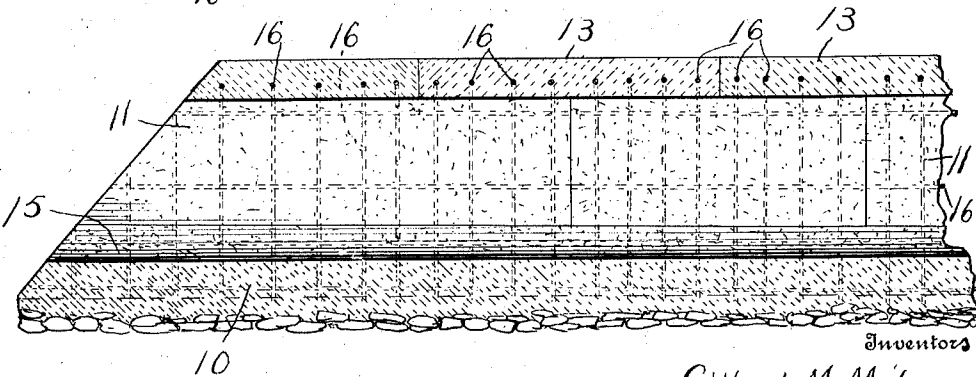

Fig. 3.



Inventors

Gilbert M. Mahoney
Frank A. Rounds.

Witnesses

J. C. Simpson.
S. R. Brattan.

By

Charles Chanda

Attorney &

UNITED STATES PATENT OFFICE.

GILBERT MAHONEY AND FRANK A. ROUNDS, OF LE ROY, MINNESOTA.

CULVERT.

No. 928,265.

Specification of Letters Patent.

Patented July 20, 1909.

Application filed September 9, 1908. Serial No. 452,264.

To all whom it may concern:~

Be it known that we, GILBERT MAHONEY and FRANK A. ROUNDS, citizens of the United States, residing at Le Roy, in the county of Mower, State of Minnesota, have invented certain new and useful Improvements in Culverts; and we do hereby declare the following to be a full, clear, and exact description of the invention, such as will enable others skilled in the art to which it appertains to make and use the same.

This invention relates to culverts and like structures employed in roadways to enable water to flow freely from one side of the road to the other without flooding the same, and for similar purposes, and has for its object to improve the construction and increase the efficiency and utility of devices of this character.

In the ordinary construction of culverts and like structures the side walls are bound together immovably, and in event of water freezing therein the walls are broken by the expansion of the ice.

In the improved device herein shown and described, provision is made for the outward movement of the side walls under abnormal pressure, so that danger of the fracture of the walls is avoided, and the integrity of the culvert insured.

The improved device comprises in general a base of cementitious material, spaced side walls formed of blocks of cementitious material resting by their lower edges upon the base and with cap blocks or members bearing upon the upper edges of the side walls and with shoulders depending therefrom and bearing between the inner faces of the side walls at their upper edges, and with a layer of cementitious material disposed upon the base between the side walls and preferably with a concaved upper surface and bearing against the inner faces of the side walls at their lower parts, so that inward movement of the side walls under pressure of the earth from the outside is effectually prevented, while at the same time the outward movement of the side walls under abnormal pressure, such as the severe strains produced by the expansion of the ice formed within the culvert is provided for, whereby danger of fracture of the side walls is prevented. A culvert is thus produced which may be employed in very cold climates without danger of fracture from the ice.

In the drawings illustrative of the pre-

ferred embodiment of the invention, Figure 1 is a perspective view of the improved culvert, Fig. 2 is a transverse section, and, Fig. 3 is a longitudinal section. Fig. 4 is a sectional detail illustrating a modification in the construction.

In the drawings, the base of cementitious material which is represented at 10 and disposed upon the ground where the culvert is to be erected is preferably of greater width than the culvert structure as shown so as to produce the requisite stability and prevent displacement by the frost, as well as to prevent any "settling" of the culvert under unusual pressure from above caused by the traffic of the road beneath which the culvert is disposed.

The culvert proper is constructed with spaced side walls and the cap bearing over the side walls, the side walls formed of blocks 11 disposed end to end, each set of blocks spaced apart a distance equal to the width of the culvert, and with their lower ends enlarged laterally as at 12 to increase the bearing surface upon the base 10 and correspondingly increase the stability of the structure. The top or cap of the closure is formed of a plurality of blocks 13 bearing at their edges upon the upper edges of the wall blocks 11 and with depending shoulders 14 bearing between the upper inner edges of the wall blocks, and thus effectually preventing inward movement of the wall blocks at their upper edges. The side wall blocks 11 and the cap blocks 13 are preferably arranged so that their joints do not come opposite each other, or with the joints "breaking" as shown in Fig. 1.

Disposed upon the base 10 between the side wall blocks 11 is a layer of cementitious material 15 with its upper face preferably concaved, to form a trough-like configuration at the lower side of the culvert to facilitate the passage of the water therethrough. The bottom layer 15 thus bears at its edges upon the inwardly projecting portion of the laterally extending lower edges of the wall blocks 11, and materially assists in holding them in their downward position. By this simple arrangement it will be obvious that a simply constructed culvert is produced which is effectually prevented from collapsing by the pressure without, while at the same time in event of abnormal pressure from within, as for instance in event of water freezing within the culvert, the side walls will

yield outwardly to such pressure, and the fracture of the blocks 11—13 prevented.

The blocks 11—13 will be formed in suitable molds, either at the point where they are to be employed or at some central point and shipped to the point where the culvert is to be erected and will generally be formed of concrete or like material. The base portion 10 and the bottom layer 15 will generally be formed where the culvert is to be erected, the layer 15 being applied before the cap members 13 are positioned upon the side walls. The blocks 11—13 may be of any required size or thickness according to the locality 15 where the culvert is to be erected, but for an ordinary culvert employed beneath an ordinary roadway, the blocks will generally be about 18" wide, 4' long and 5" thick with the depending portion of the cap block about 1" 20 thick. The blocks 11—13 will be reinforced by embedding therein a plurality of wires represented at 16, which materially increase the strength and effectually prevent fracture under the severe strains to which the blocks 25 will be subjected.

The structure may be employed for various purposes but as before stated is particularly adapted to the construction of culverts beneath roadways, to provide for the require- 30 site drainage from side to side of the road.

The reinforcing wires may be in the form of woven wire fencing material as represented in Fig. 3, and the wires may be of the barbed construction as shown in Fig. 4, or smooth 35 as in Fig. 2 as preferred.

What is claimed, is:—

1. A culvert comprising a base portion of cementitious material having a uniformly level upper surface, side walls spaced apart 40 and formed of a plurality of blocks of cementitious material bearing at their lower edges upon said base, cap members formed of blocks of cementitious material and bearing upon said side wall blocks and with shoulders 45 extending between the same, and a layer of cementitious material disposed between said side wall blocks and upon said base with the

upper face concaved, and preventing inward movement of the side wall blocks while leaving them free to move outwardly upon the level base under abnormal pressure. 50

2. A culvert comprising a base portion of cementitious material, side walls spaced apart and formed of a plurality of blocks of cementitious material and with laterally extended lower edges bearing upon the level topped base, cap members formed of blocks of cementitious material and bearing upon said side wall blocks and with shoulders extending between the same, and a layer of cementitious material disposed between said side wall blocks and upon the inner portions of said lateral extensions and likewise upon said base and preventing inward movement and locking the side wall blocks against upward movement while leaving the said side wall blocks free to move outwardly under abnormal pressure upon the level base. 65

3. A culvert comprising a base portion of cementitious material having a uniformly level upper surface, side walls spaced apart and formed of a plurality of blocks of cementitious material having reinforcing wires embedded therein and bearing at their lower edges upon said base, cap members formed of blocks of cementitious material and reinforced by wires embedded therein and bearing upon said side wall blocks and with shoulders extending between the same, and a layer of cementitious material disposed between said side wall blocks and upon said base and with a convex upper surface and preventing inward movement of the side wall blocks while leaving them free to move outwardly upon the level base under abnormal pressure. 80 85

In testimony whereof, we affix our signatures, in presence of two witnesses.

GILBERT MAHONEY.
FRANK A. ROUNDS.

Witnesses:

E. E. HALL,
W. M. FRANK.