



US 20050280222A1

(19) **United States**

(12) **Patent Application Publication**  
**Sauter et al.**

(10) **Pub. No.: US 2005/0280222 A1**

(43) **Pub. Date: Dec. 22, 2005**

(54) **IN-LINE ROLLER SKATE WITH INTERNAL SUPPORT AND EXTERNAL ANKLE CUFF**

(75) Inventors: **Thomas M. Sauter**, Seattle, WA (US);  
**Antonin A. Meibock**, Calgary (CA);  
**John E. Svensson**, Buk-ku Pasan (KR)

now Pat. No. 6,168,172, which is a continuation-in-part of application No. 08/484,467, filed on Jun. 7, 1995, now abandoned, which is a continuation of application No. 08/094,576, filed on Jul. 19, 1993, now Pat. No. 5,437,466.

**Publication Classification**

(51) **Int. Cl.<sup>7</sup>** ..... **A63C 17/02**  
(52) **U.S. Cl.** ..... **280/11.221**

Correspondence Address:

**CHRISTENSEN, O'CONNOR, JOHNSON,  
KINDNESS, PLLC  
1420 FIFTH AVENUE  
SUITE 2800  
SEATTLE, WA 98101-2347 (US)**

(57) **ABSTRACT**

(73) Assignee: **K-2 Corporation**, Vashon, WA (US)

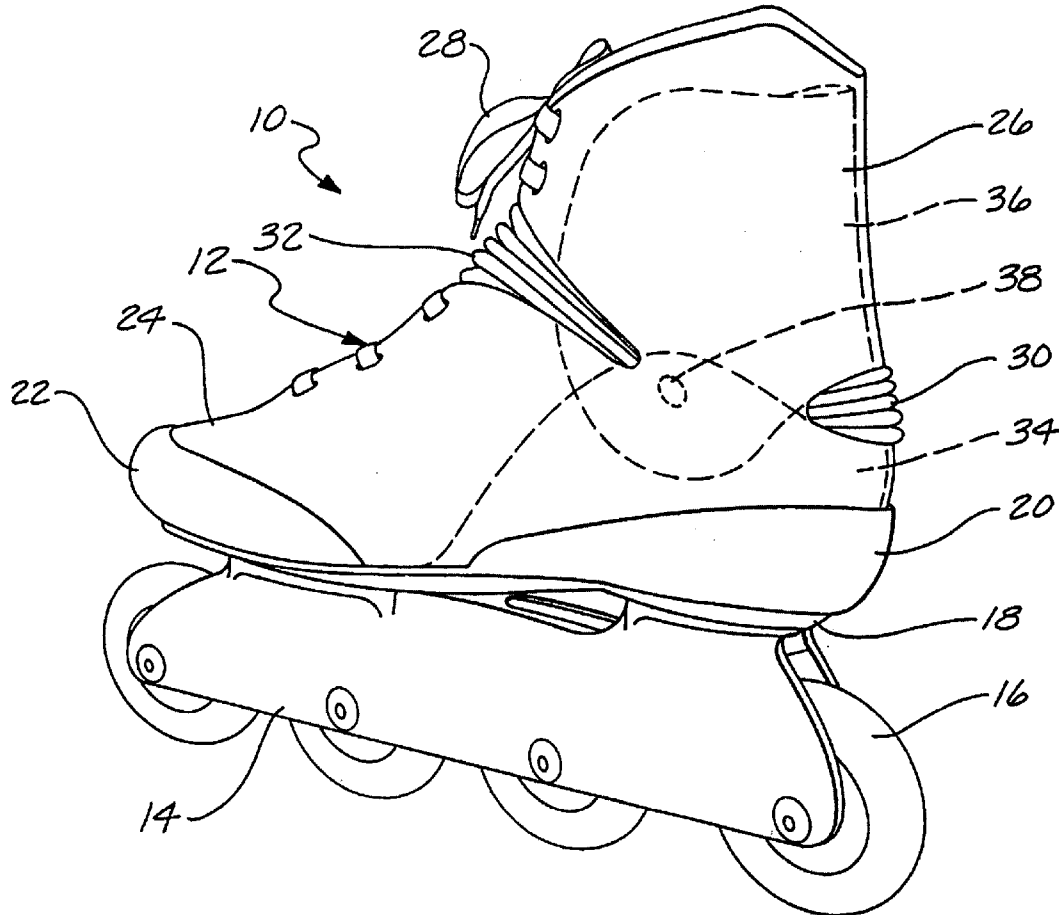
(21) Appl. No.: **11/213,095**

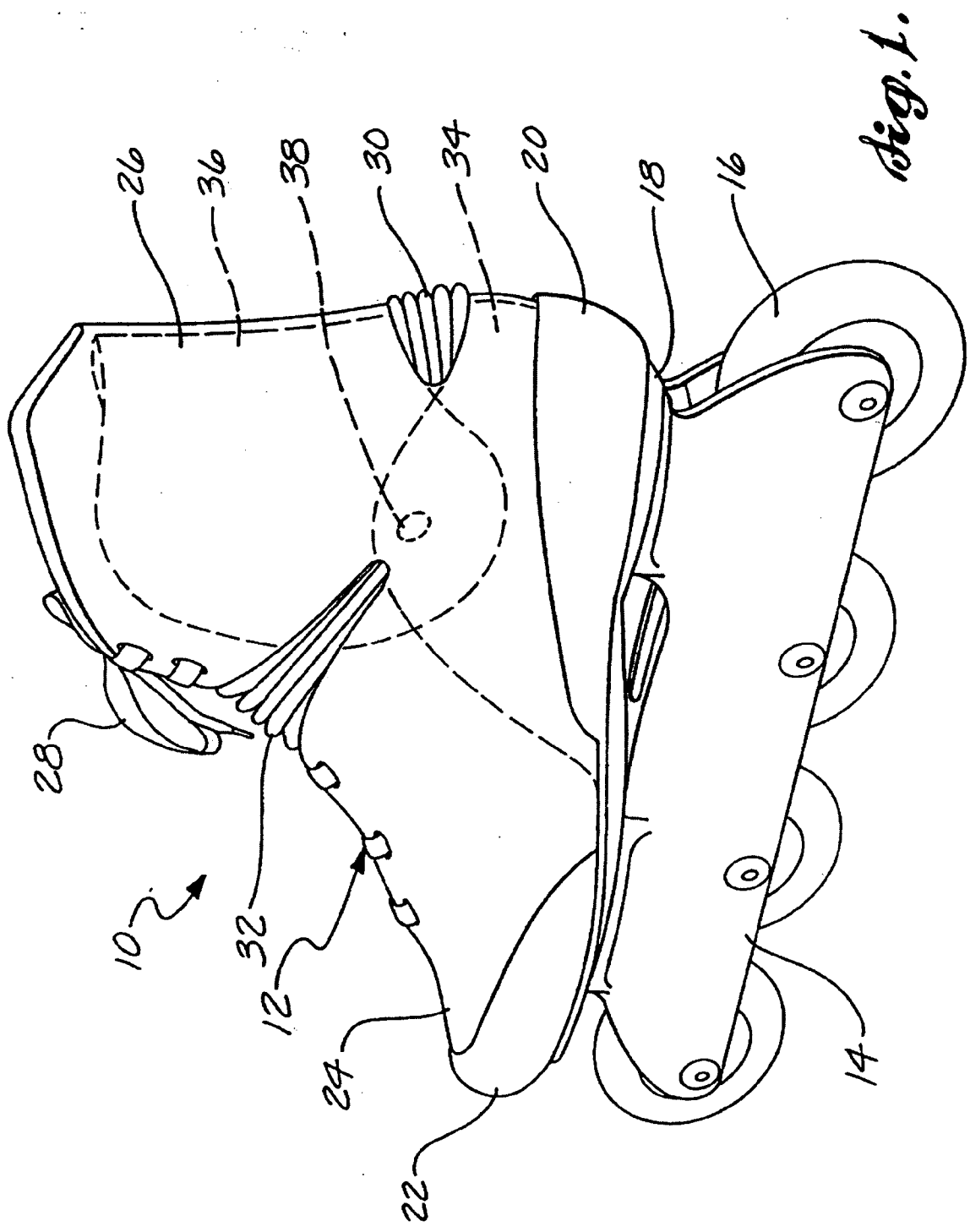
(22) Filed: **Aug. 26, 2005**

**Related U.S. Application Data**

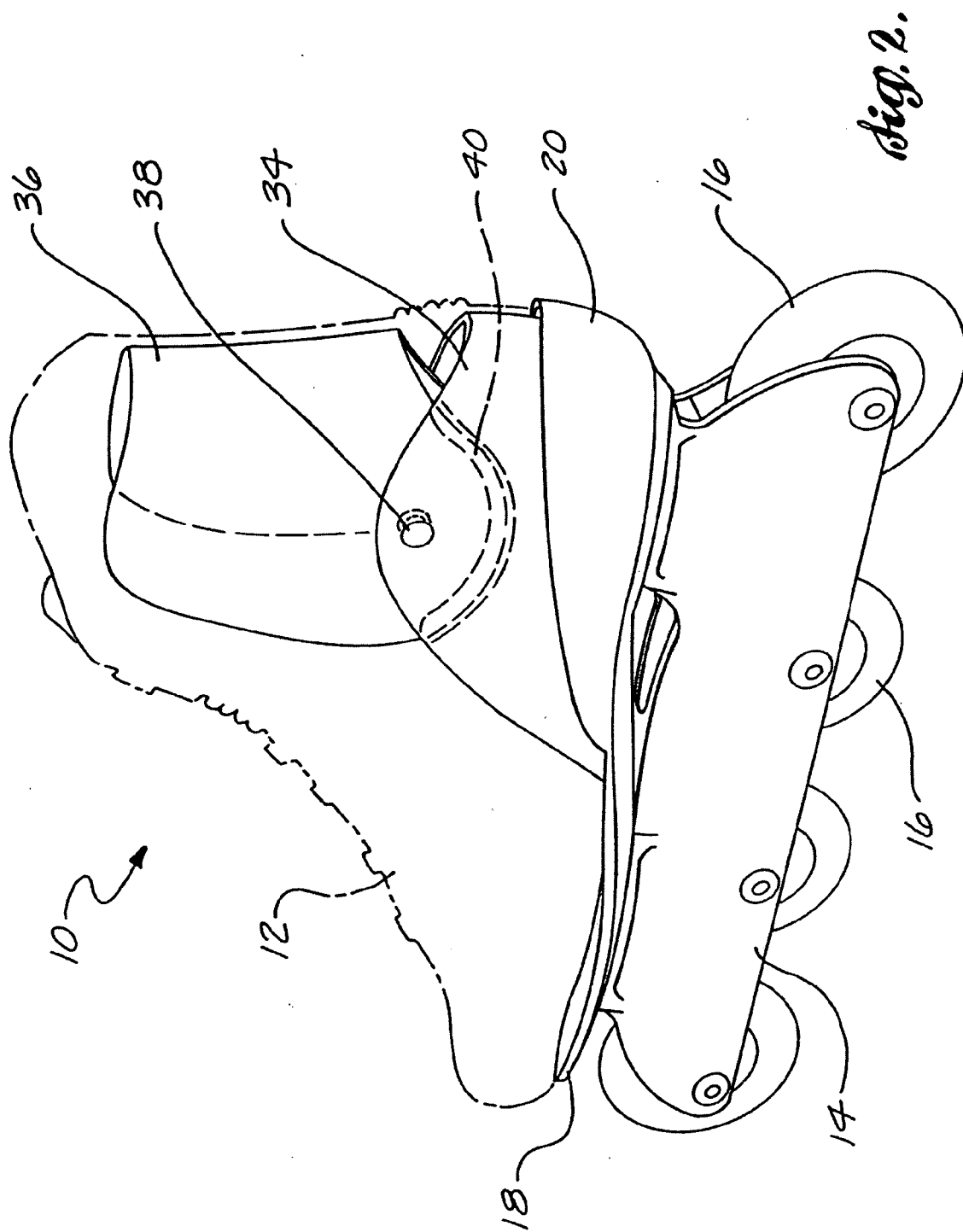
(63) Continuation of application No. 10/617,317, filed on Jul. 9, 2003, now abandoned, which is a continuation of application No. 09/753,750, filed on Jan. 2, 2001, now abandoned, which is a continuation-in-part of application No. 08/668,278, filed on Jun. 21, 1996,

A roller skate includes an upper, including a substantially nonrigid upper portion secured to a base. A frame secured to the base carries a plurality of wheels. The substantially nonrigid upper portion is reinforced by a substantially rigid internal heel counter. An ankle support cuff assembly is pivotally secured to the internal heel counter. The ankle support cuff assembly includes a substantially rigid ankle support cuff that is pivotally secured on lateral and medial sides to the internal heel counter. Ankle pad lines the interior of the ankle support cuff. Ankle support cuff is fastened by a selectively securable fastener about the skater's ankle. The ankle support cuff assembly pivots freely in the forward and aft direction relative to the internal heel counter.

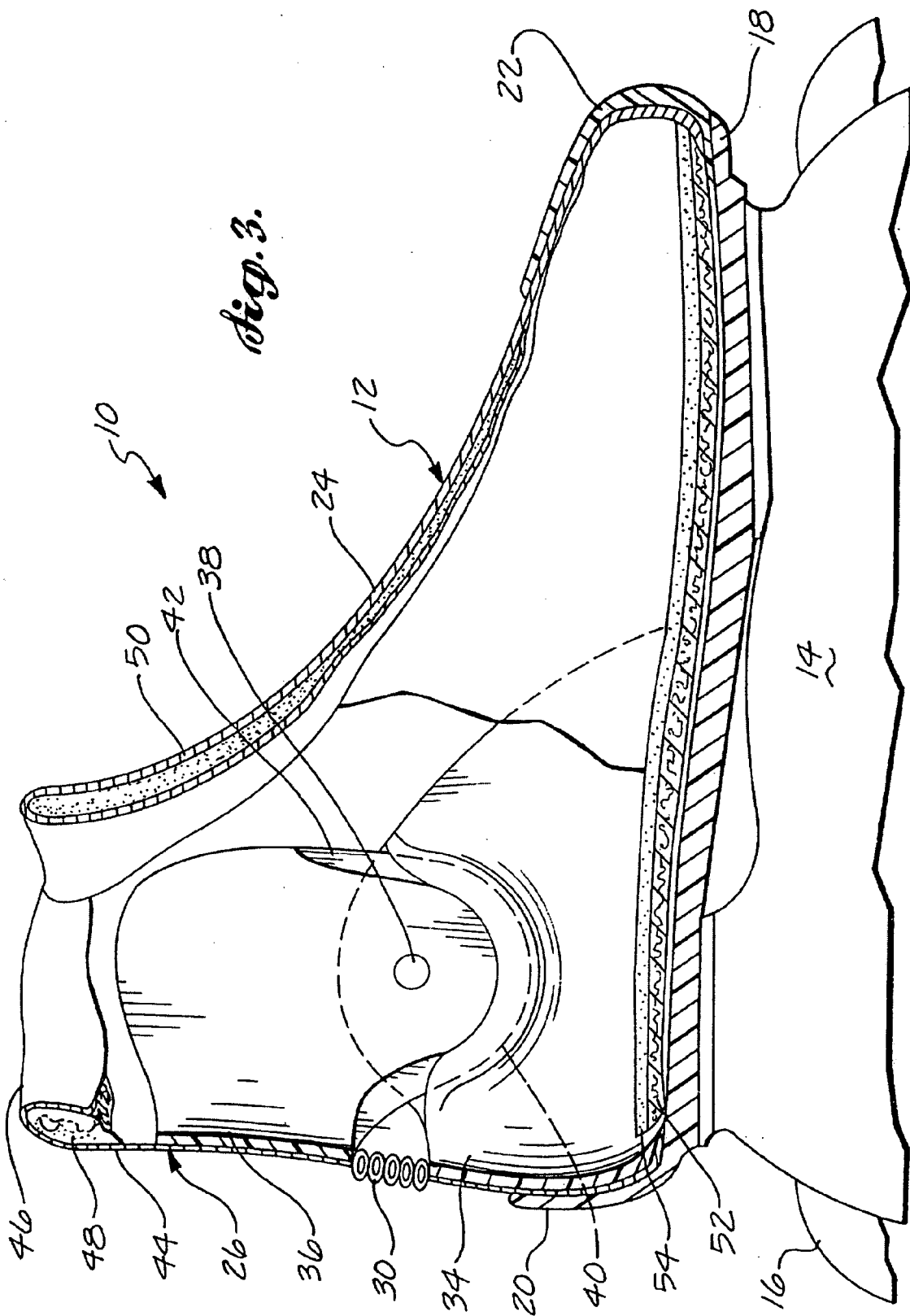


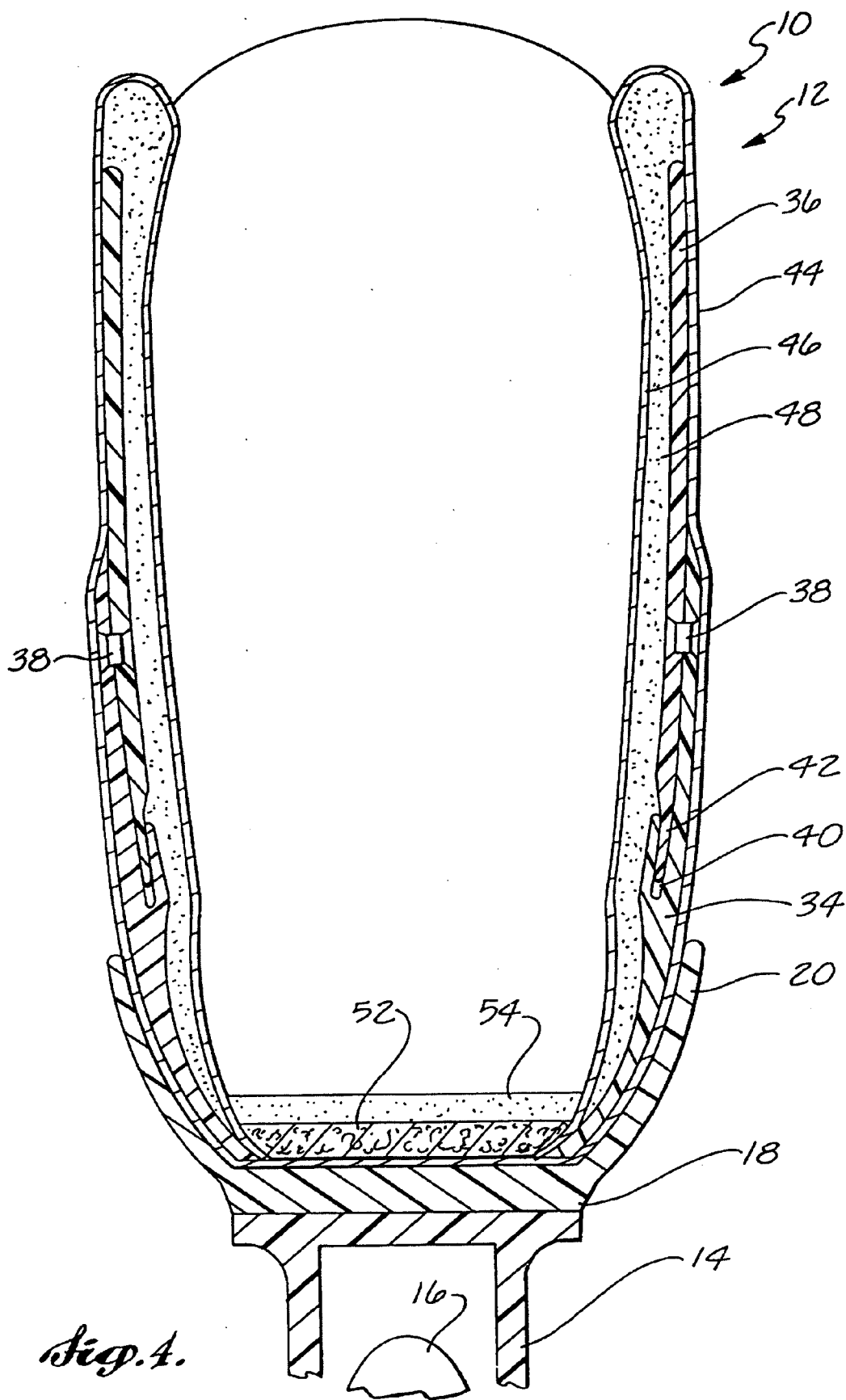


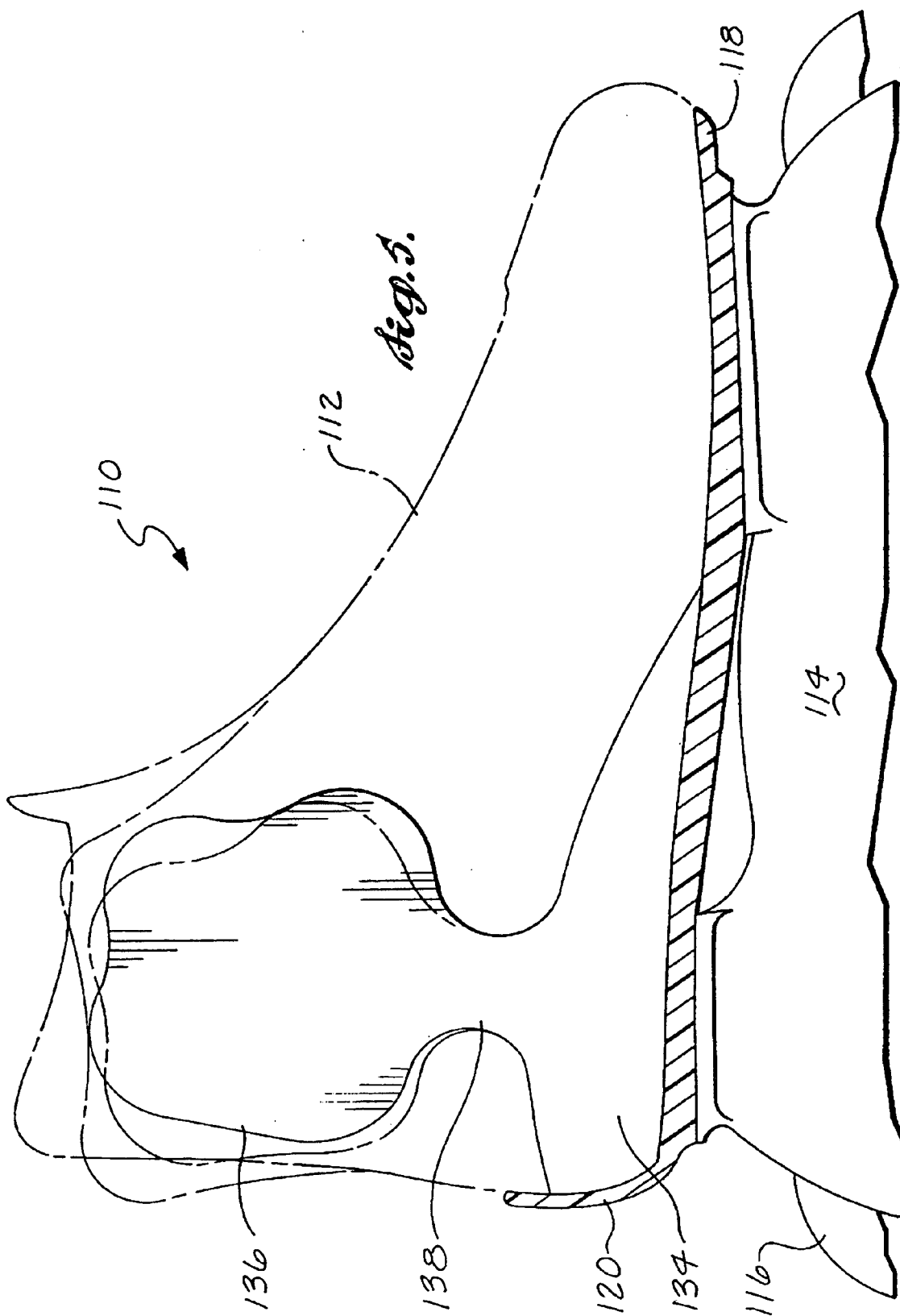
*Fig. 1.*

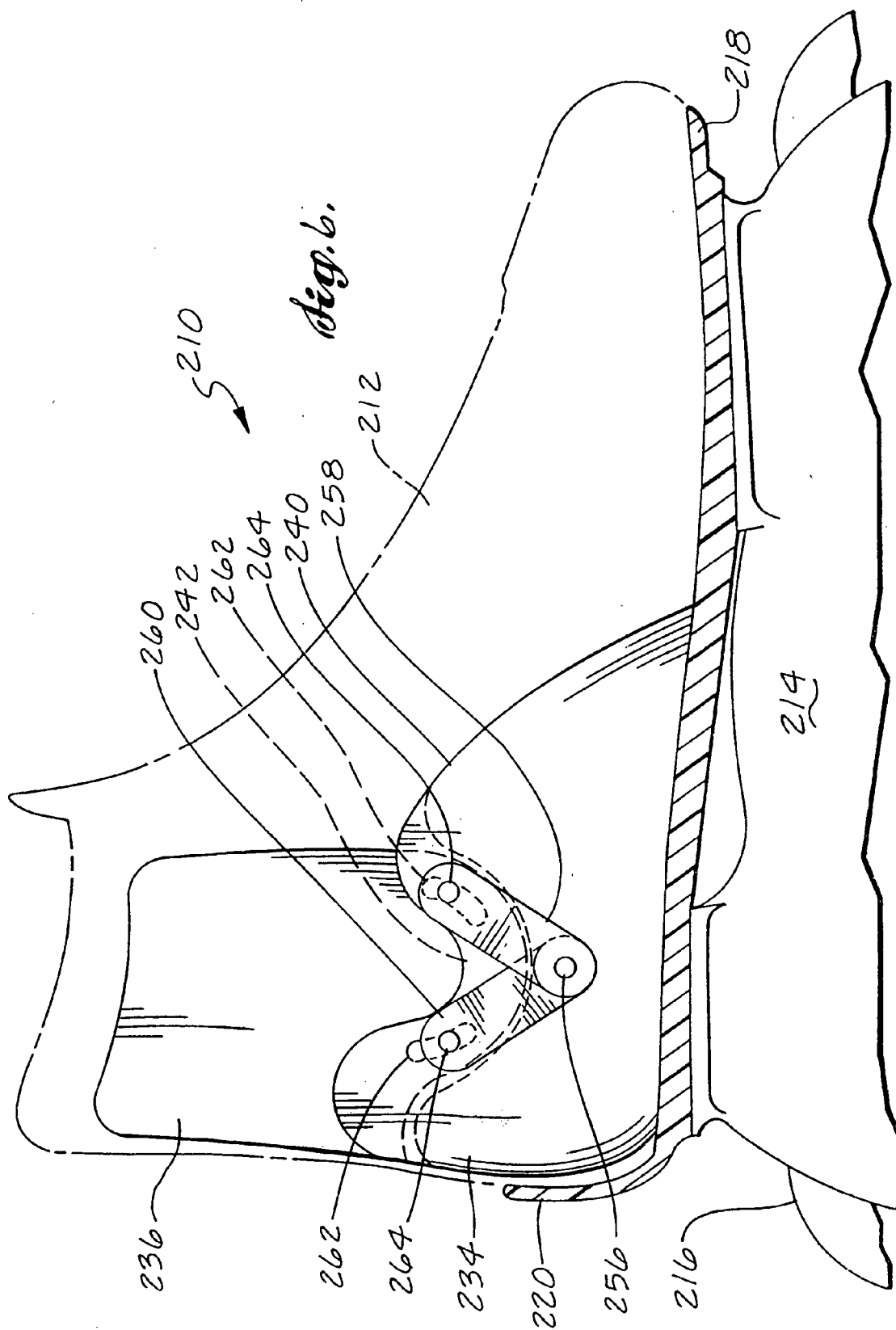


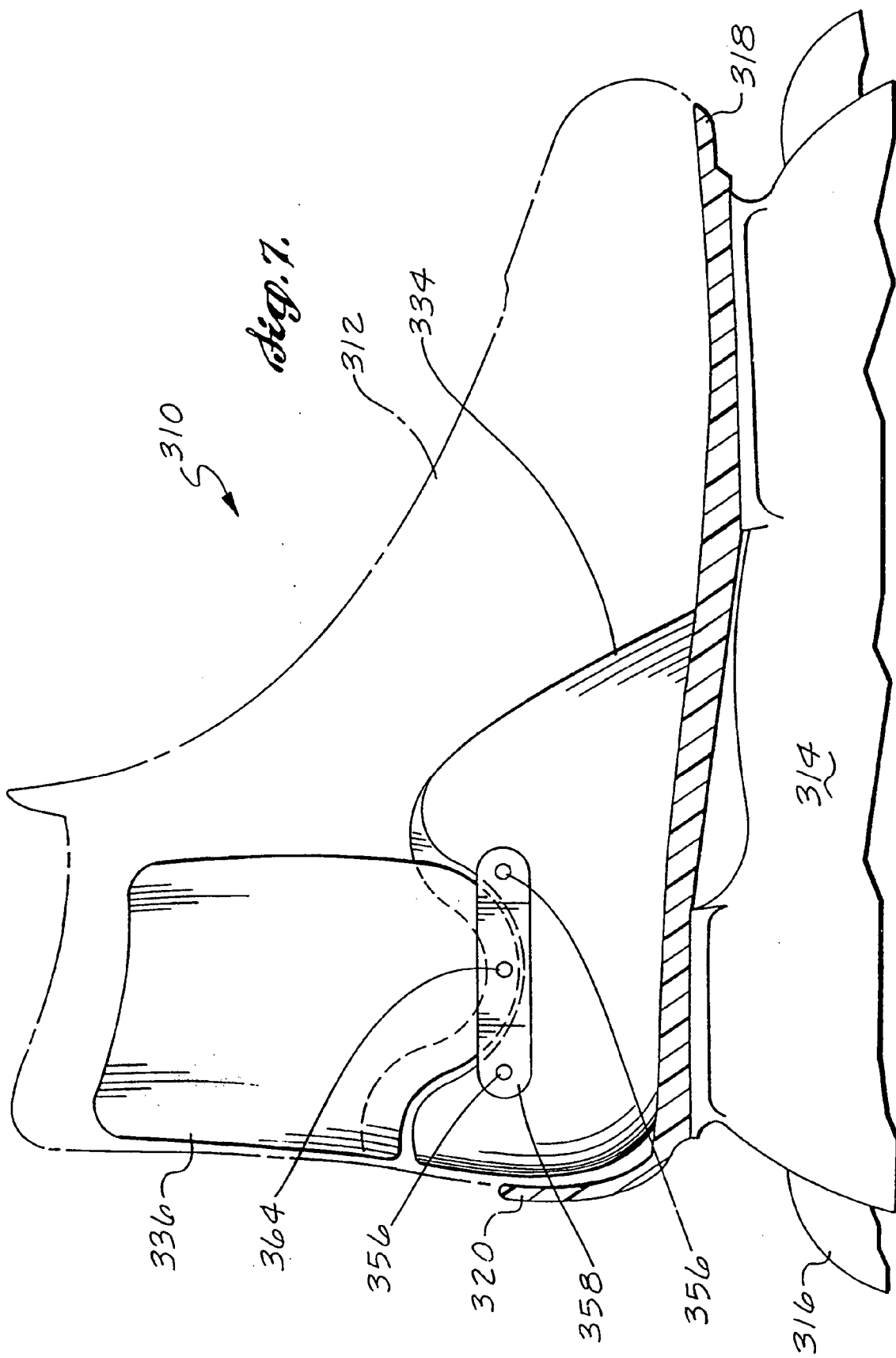
*Fig. 2.*



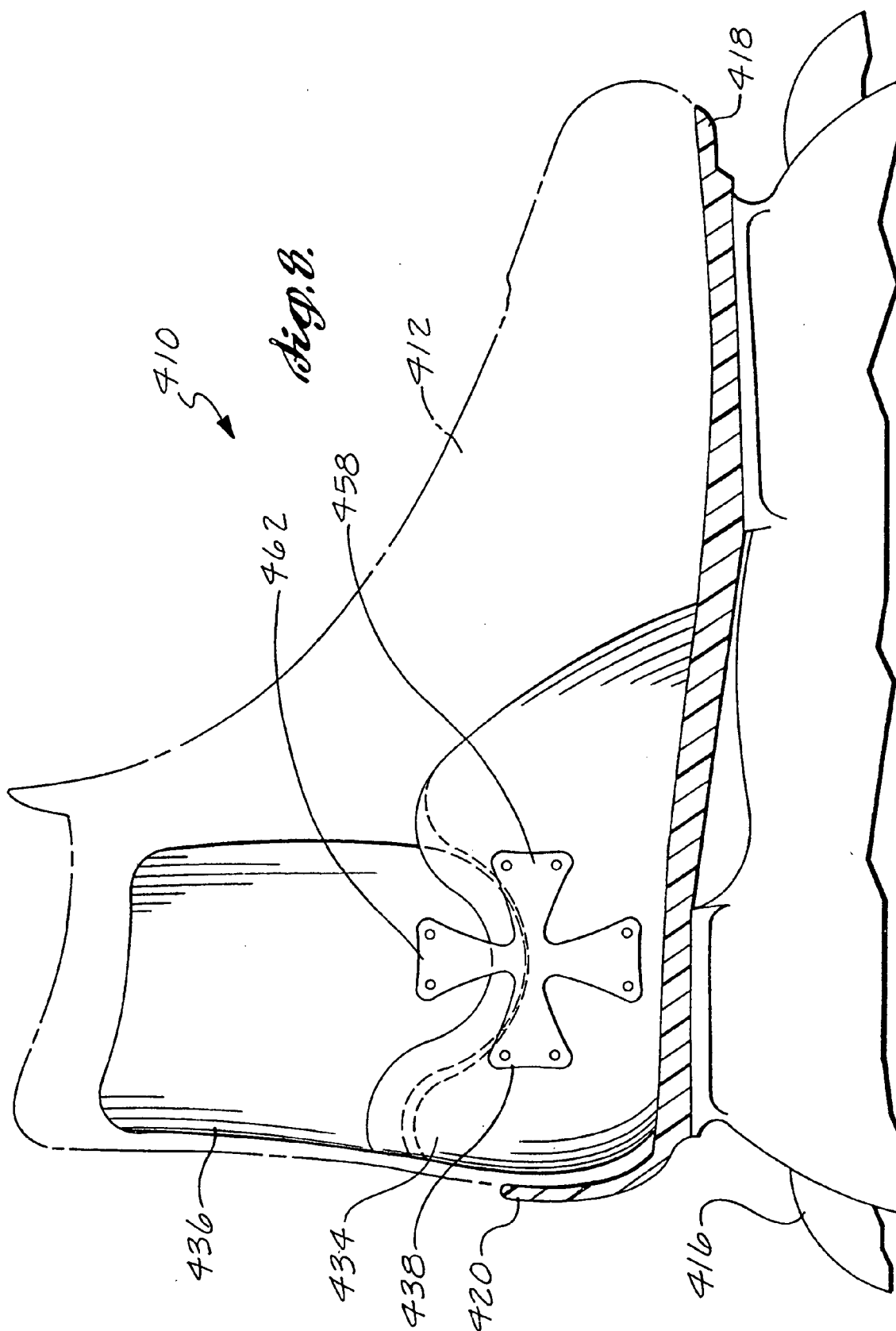


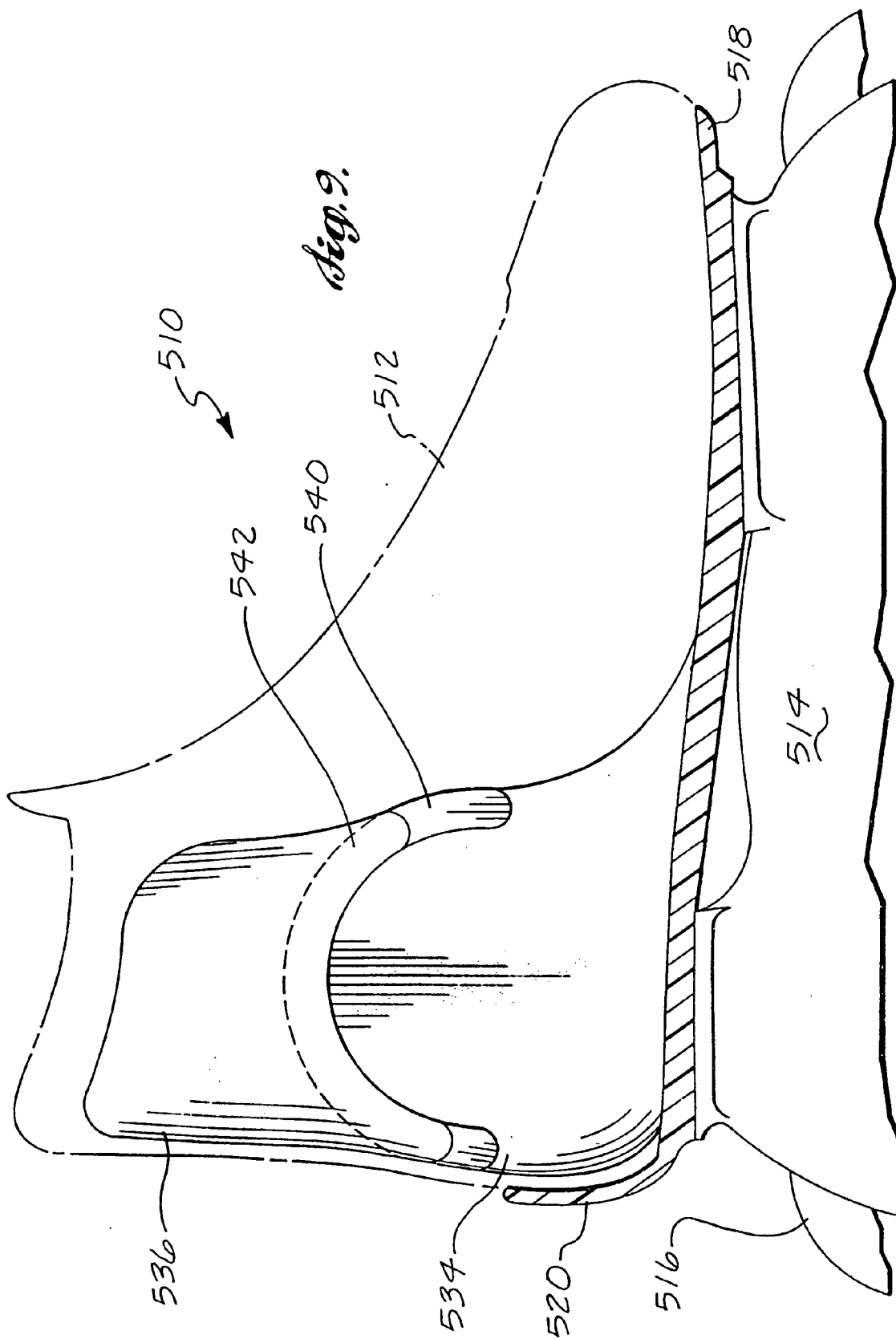


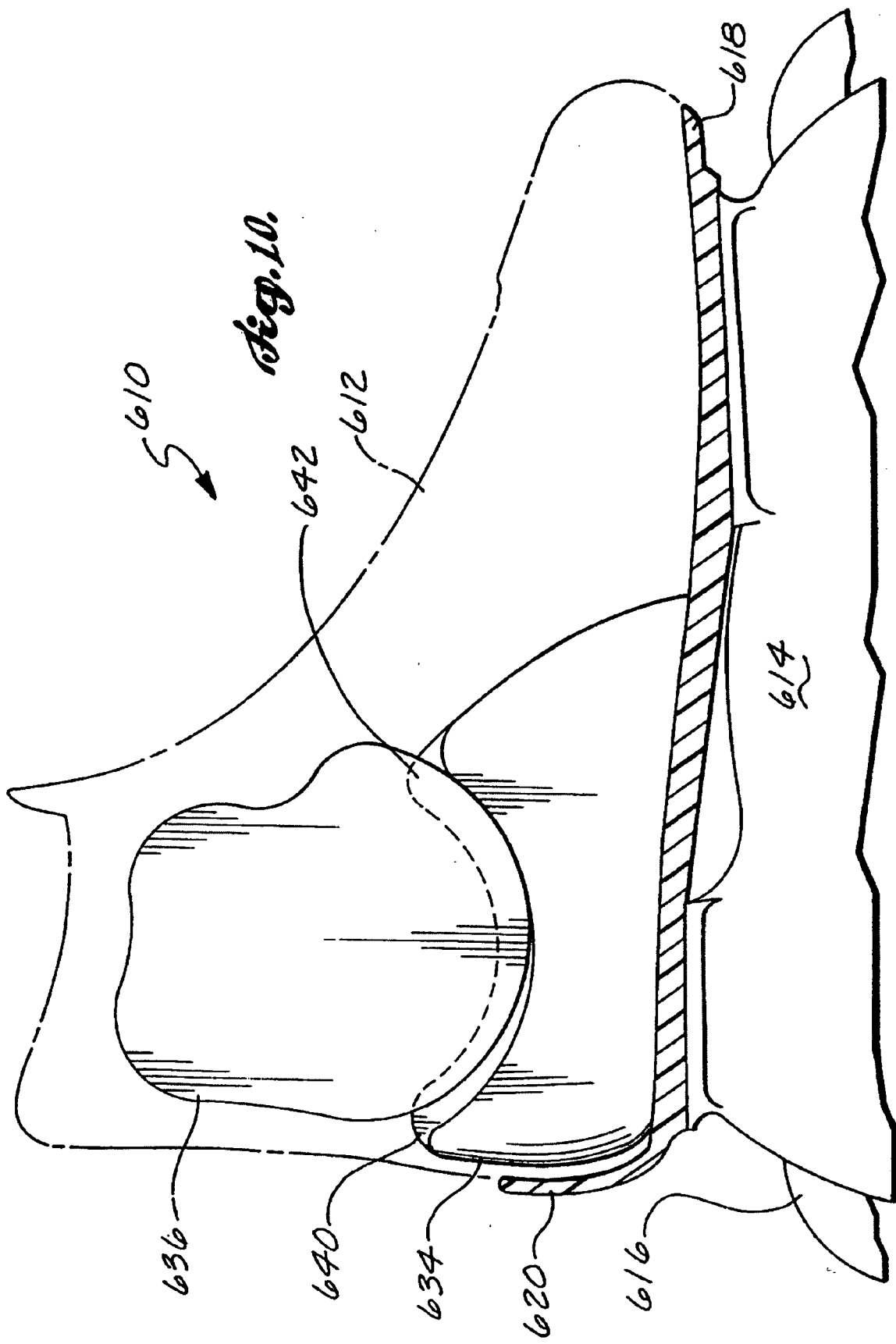


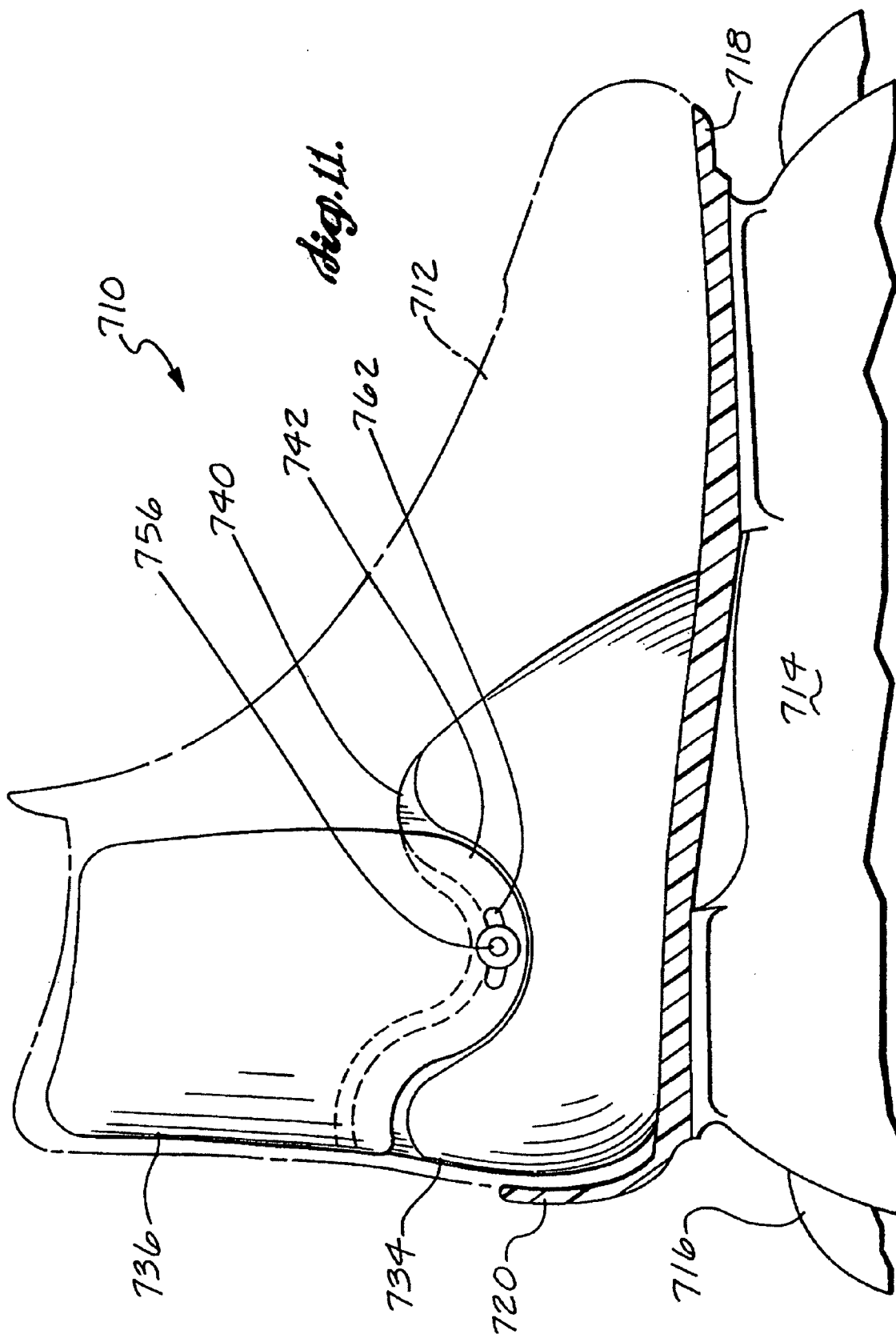


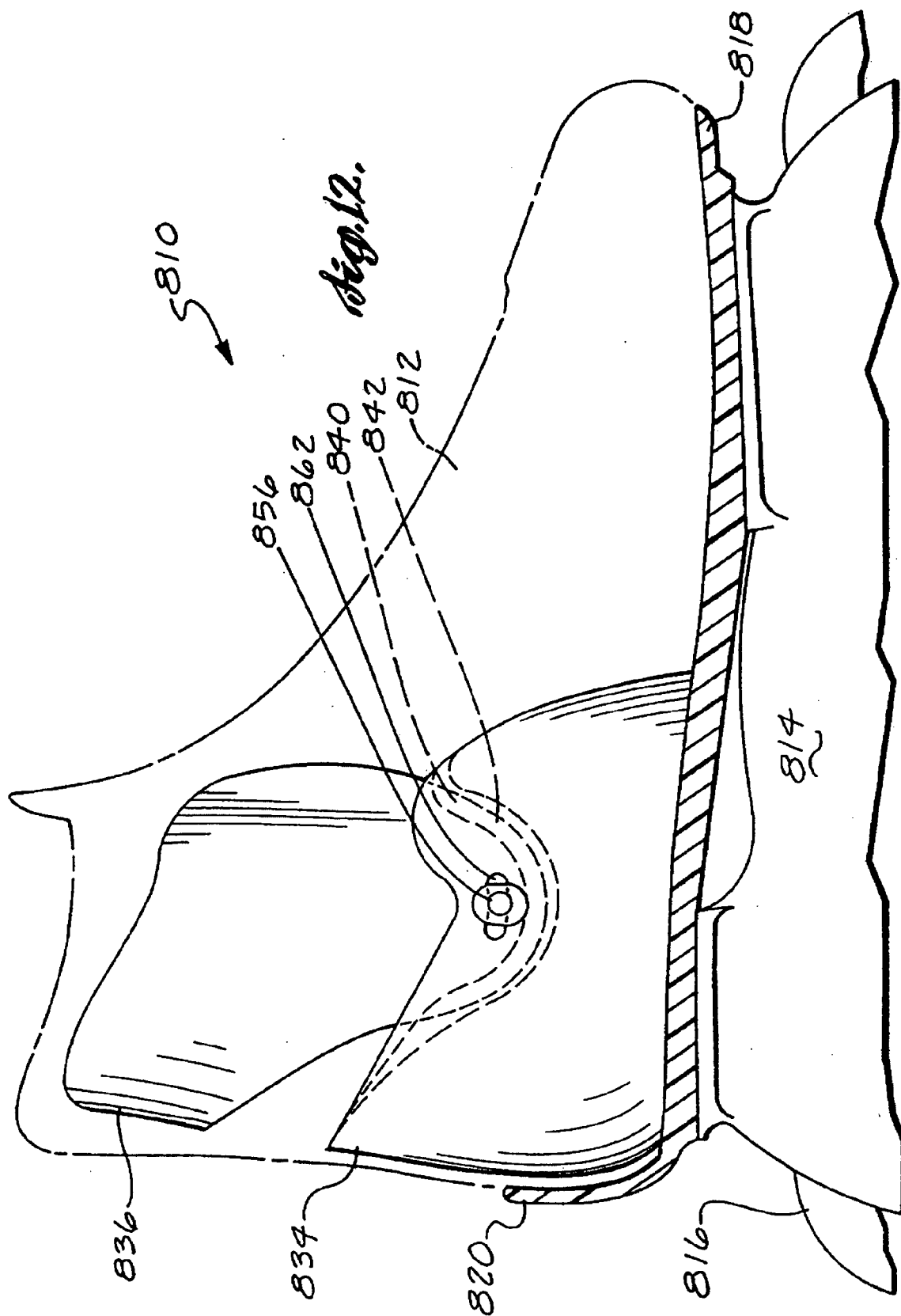


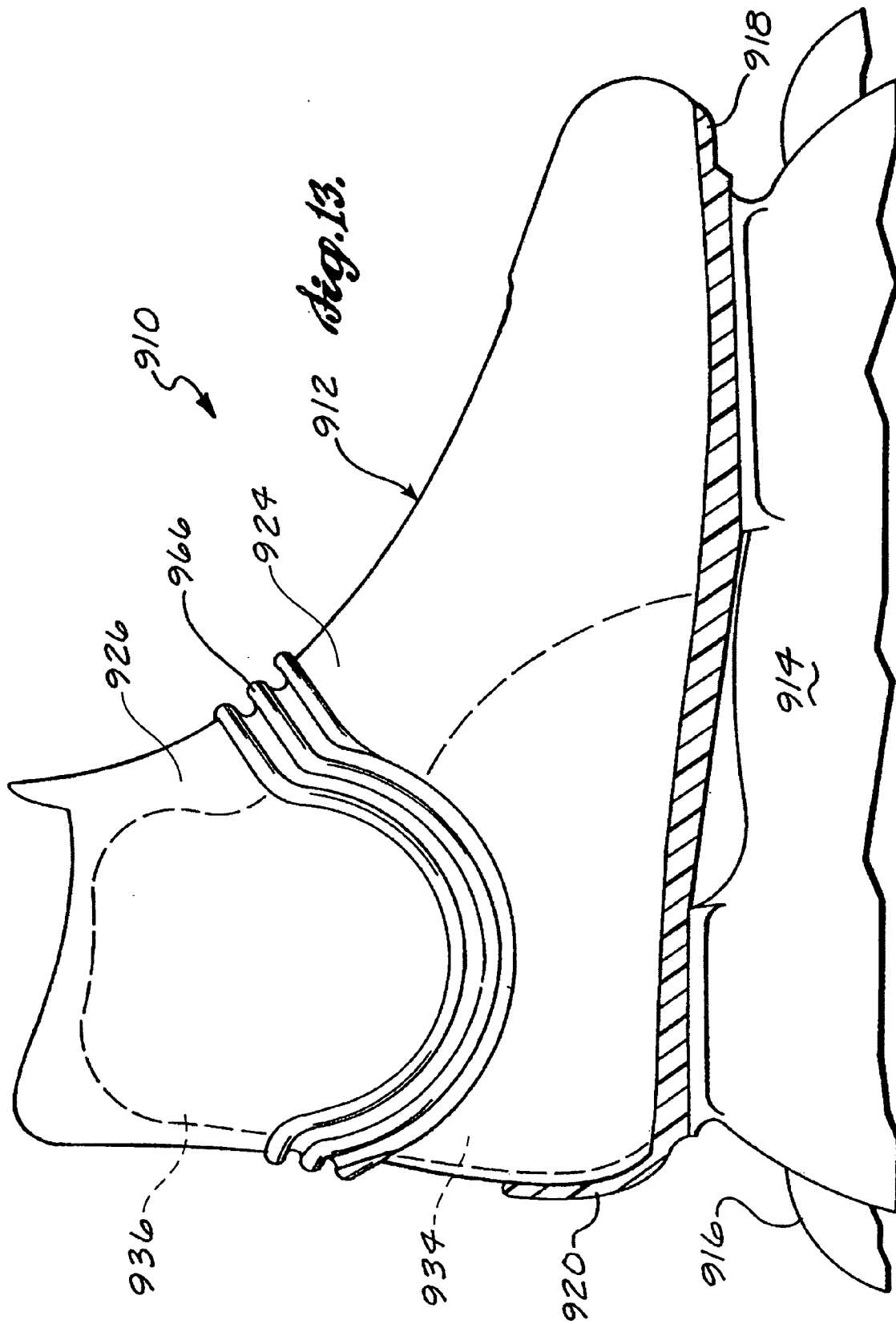


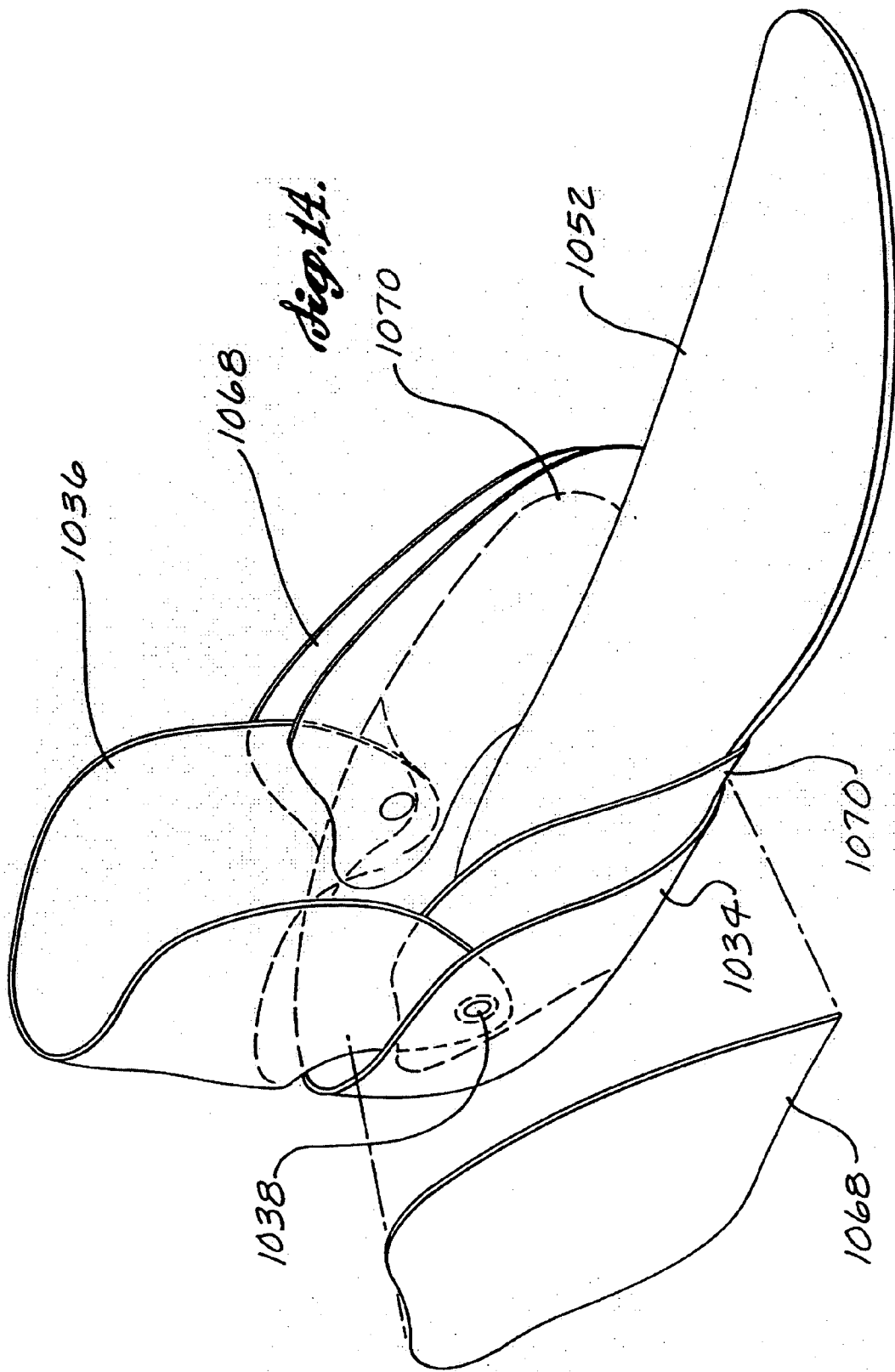












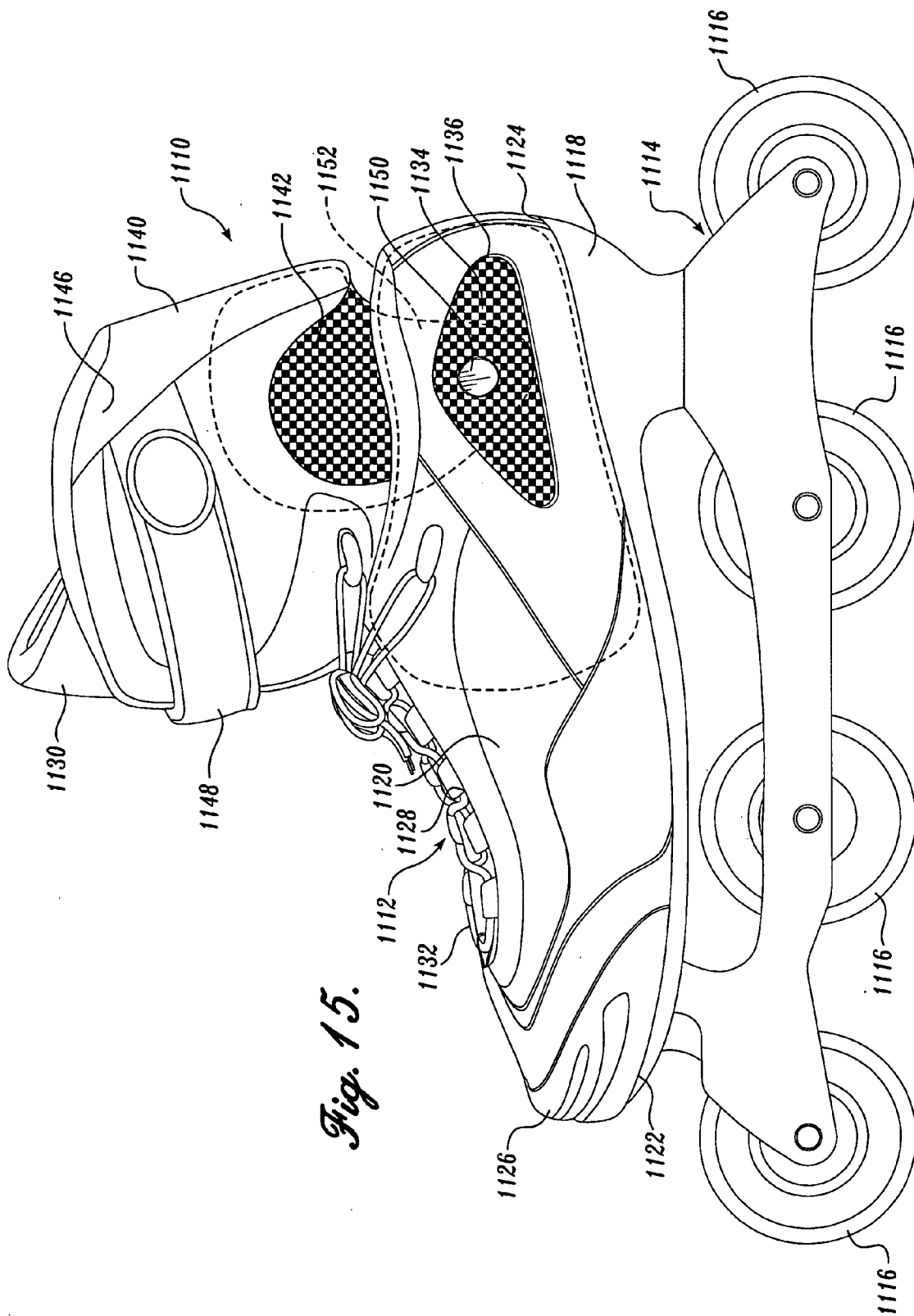
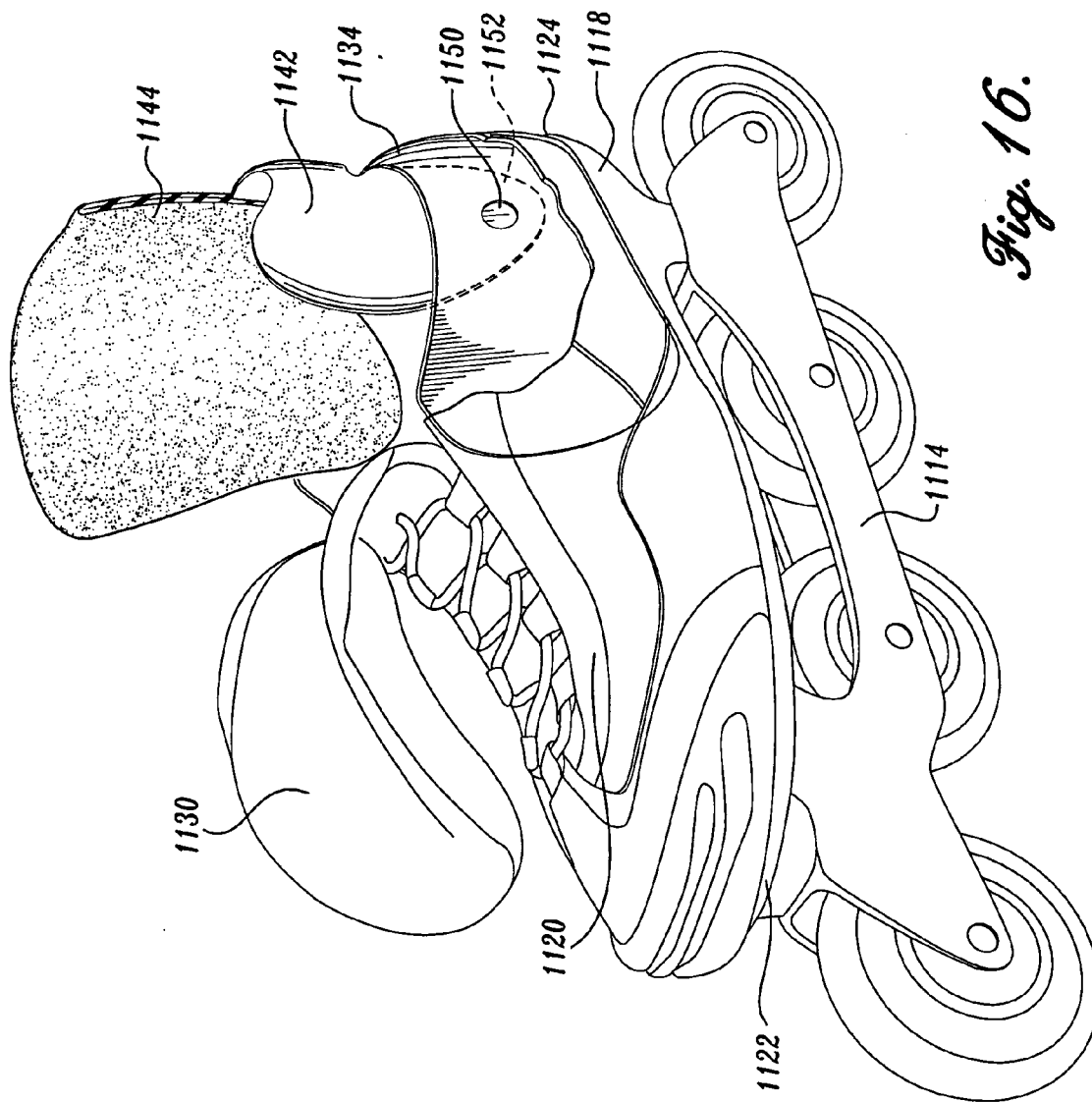
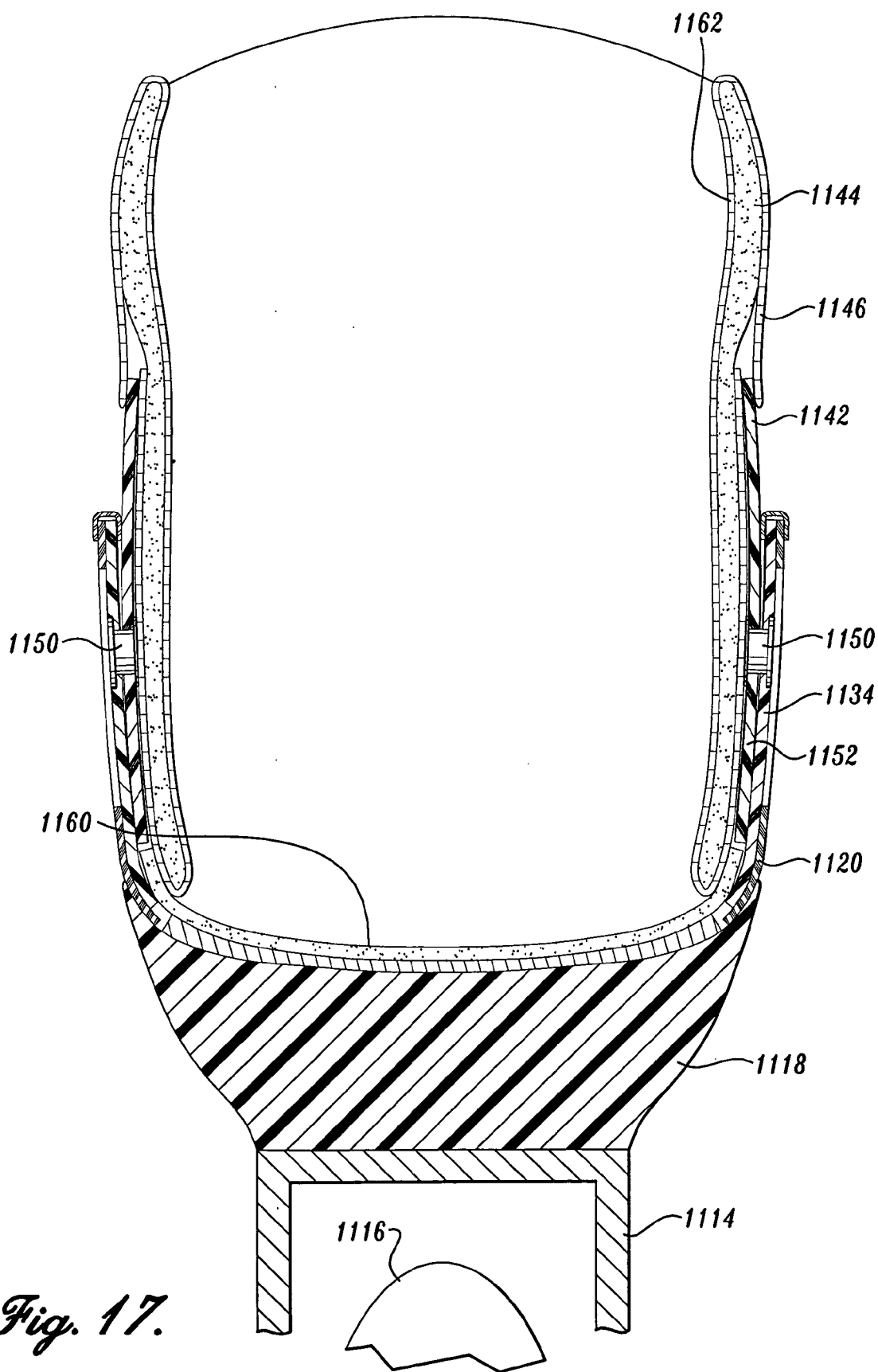


Fig. 15.





*Fig. 16.*



*Fig. 17.*

## IN-LINE ROLLER SKATE WITH INTERNAL SUPPORT AND EXTERNAL ANKLE CUFF

### CROSS-REFERENCES TO RELATED APPLICATIONS

[0001] This is a continuation of U.S. application Ser. No. 10/617,317, filed Jul. 9, 2003, which is a continuation of U.S. application Ser. No. 09/753,750, filed Jan. 2, 2001, now abandoned, which is a continuation-in-part of U.S. application Ser. No. 08/668,278, filed Jun. 21, 1996, now U.S. Pat. No. 6,168,172, which is a continuation-in-part of U.S. application Ser. No. 08/484,467, filed Jun. 7, 1995, now abandoned, which is a continuation of U.S. patent application Ser. No. 08/094,576, filed Jul. 19, 1993, now U.S. Pat. No. 5,437,466.

### FIELD OF THE INVENTION

[0002] The present invention relates to in-line roller skate constructions and, more particularly, to pivoting ankle support structures for in-line roller skates.

### BACKGROUND OF THE INVENTION

[0003] In-line roller skates typically include a plurality of aligned wheels with parallel axles secured to a skate frame. A skate boot or shoe is attached to the top of the frame. Most skate manufacturers currently construct the boots and shoes ("the skate upper") with a base, a plastic shell extending upwardly from the base, and a removable liner. The shell may include a cuff portion pivotally attached to a lower portion of the shell to ease fore and aft movement of the skater's leg while providing medial and lateral support. Alternatively, the plastic shell may extend upwardly to the top of the skate above the ankle without the cuff being pivotally secured to the lower portion. Rigid hockey skates are also in the prior art. These skates typically do not have a plastic outer shell. Hockey skates may have a leather or leather/nylon outer shell with internal stiffening/support members. While hockey skate constructions provide necessary support for this sport, they do not easily flex forwardly and rearwardly.

[0004] Most in-line roller skates are very maneuverable and are capable of higher speeds than those customarily associated with conventional paired wheel roller skates. In-line roller skating is generally considered to require higher levels of skill, coordination, and strength than conventional paired wheel roller skating because of the narrow, lateral support base associated with in-line roller skates. Specifically, while balancing in the forward and rear direction is relatively easy for even inexperienced skaters, balancing in the sideward or lateral direction is difficult because of the narrow support base and is heavily dependent upon the skater's balancing and coordination skills. Proper ankle and foot supports within the upper shoe portion of the in-line roller skate aid in lateral balancing.

[0005] To obtain the optimum performance from an in-line roller skate, it is important that the in-line roller skate be maintained in a substantially vertical position. The upper shoe portion of the in-line roller skate serves competing purposes of providing support and comfort; comfort in a shoe not usually being associated with a high degree of support. In other words, the incorporation of rigid support structures in the upper shoe portion of the in-line roller skate

tends to add stiffness and bulk and, considering the warm weather environments conducive to in-line roller skating, tends to make the skates heavy, hot, and uncomfortable. Because serious ankle and other injuries can result if comfort is favored over support, proper support in an in-line roller skate has been the dominant design criteria in the past.

[0006] As discussed briefly above, the conventional upper shoe portion of the in-line roller skate is usually formed of rigid, nonbreathable, plastic materials having an inner liner. The plastic material generally forms the outer structure of the upper shoe portion, thereby requiring that a soft inner liner of sponge rubber or other like material be included to provide comfort to the user. Since such soft materials combined with the rigid plastic shell are good insulators and do not readily transmit heat or air away from the user's foot, the result is a hot upper shoe portion.

[0007] To provide lateral stability, conventional alpine ski boot designs have readily been adapted to in-line roller skates. These boots provide support and durability, characteristics necessary for in-line roller skates. U.S. Pat. Nos. 4,351,537 and 5,171,033 ("the '033 patent") are both exemplary of rigid, injection-molded boots adapted to winter sports, such as ice skating and alpine skiing, which have been modified for in-line roller skating applications. These patents disclose an upper boot portion that comprises a hard plastic outer shell with a soft inner liner. While this type of boot design is well-suited for cold weather sports, the upper shoe portion tends to be hot and uncomfortable when used in warm weather sports such as in-line roller skating. The '033 patent suggests that by including "primarily unobstructed ventilation ports" in the rigid synthetic outer shell of the upper shoe portion, air can circulate around the skater's foot, thereby eliminating some of the heat associated with the hard plastic outer shell. While this patent seeks to address the issue of comfort, the disclosed upper shoe portion is still configured of two parts, including a hard plastic outer shell and a soft inner liner, that in warm weather conditions can be uncomfortable compared to conventional walking and/or running shoes due to excessive heat buildup. The result is that the skater's feet are often hot, damp, and uncomfortable.

[0008] Another problem with the adoption of injection molded ski-type boots to in-line roller skating is that, while providing excellent lateral stiffness and rigidity for lateral ankle support, these boots also create unnecessary and unwanted forward/rearward stiffness and rigidity. Ski-type boots detract from the performance characteristics of the skate because they limit the range of motion of the skater's legs and feet and, therefore, the ability of the skater to utilize the full extent of his strength and agility.

[0009] Further, it is desirable for an in-line roller skate upper shoe portion to be lightweight. Boots that are well-suited to skiing applications wherein it is not necessary to raise and lower the boot with every movement of the foot (because the skier relies on gravity to provide the forward or downward motion) prove heavy and bulky when adapted to in-line roller skating. When skating on a flat surface, the in-line roller skater must lift the boot with every stride to provide a forward impetus and a heavy upper shoe portion causes fatigue and reduces skating enjoyment.

[0010] Alternative modes of providing both comfort and adequate support for in-line roller skating have been sug-

gested. Specifically, U.S. Pat. Nos. 3,963,252, 4,418,929, and 5,069,462 show roller skate frames that include a platform adapted to allow the skater to wear a conventional street shoe that is inserted into a series of braces and supports. These skates offer alternative shoe and frame designs to the rigid plastic outer shell and inner liner of the conventional in-line roller skate. However, significant problems exist with such designs in that the adjustable braces and supports of these designs, while needed to accommodate numerous shoe sizes and shapes, are bulky and uncomfortable. Additionally, there is a limited range of shoe types that the skates will accommodate and, thus, there is the additional requirement that the skater have the proper shoe type to properly utilize the skate.

[0011] The outer plastic shells of previous in-line roller skates have created difficulty in styling the skates, such as has been done with hiking boots and other footwear that have not had rigid outer shells. However, the rigid outer shells were thought to be necessary to provide adequate medial and lateral support while allowing ease of fore and aft movement of the leg of the skater relative to the skater's foot during skating. A recreational skater may not have the required strength and ability to utilize a low-cut skate that provides ease of movement. The skate would not provide enough lateral and medial support. Skates that do provide lateral and medial support and that do not include the rigid plastic outer shell construction include hockey skates. Hockey skates do provide adequate lateral and medial support for the skater's ankle. However, fore and aft movement of the lower leg of the skater relative to the skater's foot is also limited. The hockey skate uppers are generally quite rigid and unforgiving. Therefore, a need exists to provide a skate that includes an upper structural support member for medial and lateral support while providing for ease of fore and aft movement without totally encompassing the skater's foot in a rigid plastic shell.

#### SUMMARY OF THE INVENTION

[0012] In accordance with the present invention, a skate for receiving a foot of a skater is disclosed. The skate includes a frame, a rigid base, a substantially nonrigid upper portion, and a substantially rigid upper portion. The frame has a means for riding on a surface. The rigid base is securely attached to the frame. The base is adapted to support the bottom of the skater's foot and includes a heel portion and a toe portion adapted to support the areas beneath the heel, ball, and toes of the skater's foot. The substantially nonrigid upper portion is adapted to receive the skater's foot. It substantially covers the top and ankle of the skater's foot and is permanently affixed to the rigid base. The substantially rigid upper portion is coupled to the nonrigid upper portion and to the rigid base. The rigid upper portion includes an ankle support cuff extending above the skater's ankle when wearing the skate. The rigid upper portion is adjacent only to portions of the nonrigid upper portion, leaving a substantial portion of the vamp of the skate without rigid support directly adjacent thereto. The nonrigid upper portion extends to above the cuff.

[0013] In the preferred embodiment of the invention, the substantially nonrigid upper portion includes an outer shell. The ankle support cuff is disposed beneath the outer shell. In one aspect of the invention, the substantially nonrigid upper portion also includes billows in a front portion and a rear

portion of the ankle area of the upper portion. The billows are adapted to allow flexible movement of the substantially nonrigid upper portion.

[0014] In another preferred aspect of the invention, the substantially rigid upper portion further includes an internal heel counter beneath the outer shell. The ankle support cuff is pivotally connected to the internal heel counter. An external heel counter may also extend upwardly from the base around the heel portion of the upper portion on the outside of the outer shell.

[0015] In one embodiment of the invention, the internal heel counter and the ankle support cuff are pivotally interconnected with a reduced section of heel counter material, the heel counter and ankle support cuff being integrally formed.

[0016] In the preferred embodiment of the invention, the heel counter includes two sides with recesses along the inner portion of the tops thereof. The ankle support cuff includes lower edges disposed at least partially within the recesses. Preferably, the recesses include grooves extending downwardly therein. The cuff includes downwardly-projecting tongues on either side thereof disposed within the grooves. The recesses in the sides of the heel counter are preferably arcuate in shape and complementary arcuately-shaped tongues exist on the sides of the cuff. The recesses are preferably disposed on the inner sides of the heel counter with the lower portion of the cuff overlapping the heel counter on the inner sides thereof.

[0017] A further aspect of the preferred embodiment of the invention includes substantially rigid support panels disposed on the sides of the interface between the heel counter and the ankle support cuff. The support panels are fixed to the heel counter such that the ankle support cuff is movable relative to the panels.

[0018] One aspect of an alternate embodiment of the invention includes arcuate slots within the arcuate portions of the heel counter. In this embodiment, the cuff further includes pins through the bottom arcuate portions thereof. The pins extend through the slots in the heel counter.

[0019] In another alternate embodiment of the invention, the arcuate portions of the heel counter and the arcuate portions of the cuff are interconnected with arms attached therebetween. These arcuate portions of the heel counter preferably include recesses for receiving the arcuate portions of the cuff.

[0020] The preferred embodiment of the invention may also be described as a skate for receiving a foot of the skater that includes a frame, a rigid base, an external heel counter, an upper having an outer shell, a substantially rigid internal heel counter, and a substantially rigid ankle support cuff. The frame has wheels or a blade for riding on a surface. The rigid base is securely attached to the frame. The external heel counter extends upwardly from the base around the heel portion of the skate. The outer shell is constructed of substantially soft pliable material. The internal heel counter is disposed beneath the outer shell and extends around the heel area of the skate above the top of the external heel counter. The ankle support cuff is pivotally coupled to the internal heel counter and disposed beneath the outer shell. Preferably, the internal heel counter also includes at least

one groove along at least a portion thereof for receiving the lower edge of the cuff in substantially sliding engagement therewith.

[0021] The above-described skate construction provides a skate that has great aesthetic appeal without substantial plastic material on the external body of the skate. The skate also provides superior lateral and medial support while allowing fore and aft movement of the lower leg of the skater relative to the skater's foot, with the cuff being pivotally secured within the upper.

[0022] A further embodiment of the present invention includes a substantially rigid internal heel counter and an external substantially rigid ankle cuff. The skate includes a base defining an undersurface, an upper surface, a toe end, and a heel end. A frame is secured to the undersurface of the base for mounting a plurality of wheels or other ground engaging member. A substantially nonrigid upper portion is secured to the upper surface of the base. A substantially rigid internal heel counter is secured to and extends upwardly from the heel end of the base and is received within and covered by the substantially nonrigid upper portion. The substantially rigid ankle cuff, fastenable about a skater's ankle, is pivotally secured to an upper portion of the heel counter. The substantially rigid ankle cuff is able to pivot forwardly freely relative to the internal heel counter, substantially without resistance from the nonrigid upper portion.

[0023] In a preferred embodiment, a substantially rigid ankle cuff is secured to the heel counter and substantially nonrigid upper portion only by the pivotal connection to the internal heel counter and is otherwise separate from the nonrigid upper portion. An ankle pad lines an interior surface of the ankle cuff and extends downwardly, terminating at a free lower end within the internal heel counter. This embodiment of the invention allows the ankle cuff to pivot substantially freely from resistance due to the lower portion of the skate to follow the natural motion of the lower leg of a skater.

#### BRIEF DESCRIPTION OF THE DRAWINGS

[0024] The foregoing aspects and many of the attendant advantages of this invention will become more readily appreciated as the same become better understood by reference to the following detailed description, when taken in conjunction with the accompanying drawings, wherein:

[0025] **FIG. 1** is a perspective view of one embodiment of the present invention illustrating a soft boot skate with a rigid heel counter and cuff pivotally interconnected within the outer shell of the skate;

[0026] **FIG. 2** is a perspective view of the skate of **FIG. 1** showing the soft portion of the upper and the toe cap in phantom view;

[0027] **FIG. 3** is a cross-sectional side elevational view of the skate illustrated in **FIGS. 1 and 2** with sections of the interior of the skate cut away to show the cuff/counter interface;

[0028] **FIG. 4** is a cross-sectional elevational view cut vertically through the skate and extending through the pivot locations of the cuff;

[0029] **FIG. 5** illustrates an alternate embodiment of the present invention including a pivot neck between the heel counter and internal cuff;

[0030] **FIG. 6** illustrates an alternate embodiment of the invention illustrating flex arms used between the internal cuff and heel counter;

[0031] **FIG. 7** illustrates another alternate embodiment with a single flex arm to secure the internal cuff to the heel counter;

[0032] **FIG. 8** illustrates another alternate embodiment with a flex cross at the interface between the heel counter and cuff;

[0033] **FIG. 9** illustrates an alternate embodiment with the arcuate interconnection between the internal cuff and heel counter being reversed from previous embodiments;

[0034] **FIG. 10** is a side view of an alternate embodiment without substantial interconnection between the internal cuff and heel counter other than a tongue and groove arrangement;

[0035] **FIG. 11** illustrates another alternate embodiment utilizing a pin and slot arrangement between the internal cuff and heel counter;

[0036] **FIG. 12** illustrates another alternate embodiment with a pin and slot arrangement;

[0037] **FIG. 13** is an illustration of flex billows that may be used on the external shell of the skate to provide for movement of the cuff portion of the skate relative to the lower portion;

[0038] **FIG. 14** is a perspective view of a preferred embodiment of the internal support structure of the skate showing inner and outer supports covering the joints between the internal cuff and heel counter;

[0039] **FIG. 15** provides a side elevation view of an alternate embodiment of the present invention, including an internal heel counter (shown in phantom) and an external ankle support cuff pivotally secured thereto;

[0040] **FIG. 16** provides a perspective view of the skate of **FIG. 15** with a portion of the ankle support cuff assembly broken away for clarity; and

[0041] **FIG. 17** provides a cross-sectional view of the skate of **FIG. 15**, taken through a transverse plane passing through the pivot axis of the ankle cuff.

#### DETAILED DESCRIPTION OF THE PREFERRED EMBODIMENT

[0042] Referring to **FIG. 1**, an in-line roller skate **10** made according to the present invention is disclosed. In-line skate **10** includes an upper **12** connected to a frame **14** that secures wheels **16**. Upper **12** includes a rigid base **18** for interconnection to frame **14**. Preferably, rigid base **18** extends beneath upper **12** substantially from heel to toe. An external heel counter **20** is preferably integrally formed with base **18**. Alternatively, external heel counter **20** could be omitted or formed separately, unattached to base **18**. A toe cap **22** is also separately formed and attached to base **18** to protect the toe end of the skate from scuffs and wear. A toe cap **22** also protects the skater's foot from impacts with hard surfaces.

[0043] Most of the rest of upper 12 is constructed of soft, breathable, pliable material of the type commonly used in shoes or hiking boots. Thus, synthetic or natural leathers and meshes or other fabrics may be used to construct the soft portions of upper 12. These portions include a forefoot portion 24 generally below the ankle area of the skate and an ankle portion 26 at and above the ankle portion of the skate. Laces 28 are preferably used to secure upper 12 tightly around the foot of the skater in a conventional fashion. However, buckles, straps, Velcro™-type hook-and-loop fasteners, or other fasteners may alternatively be used. In the preferred embodiment of the invention, forward billows 32 and aft billows 30 are secured within cutout portions of upper 12 just over the heel and between the ankle and forefoot portions 26 and 24 of upper 12. Forward and aft billows 32 and 30 allow ease of flexing of ankle portion 26 relative to forefoot portion 24.

[0044] Much of the construction of the upper of the skate is similar to that disclosed in U.S. Pat. No. 5,437,466, incorporated herein by reference. The skate disclosed in the parent application (U.S. Pat. No. 5,437,466) ("the '466 patent") includes a soft pliable upper. The upper disclosed in the '466 patent provides medial and lateral support as well as fore and aft flexibility with a rigid external heel counter pivotally interconnected with a rigid external cuff. The same concept is employed in the present invention. However, the present application provides further details and constructions with a rigid heel counter and cuff placed inside the relatively soft outer shell 44 of upper 12. An internal heel counter 34 is preferably attached to base 18 by connection to an outer shell 44 and a last board 52 (illustrated in FIG. 3). Internal heel counter 34 rises from base 18 beginning at approximately the middle of the sides of base 18 upwardly toward ankle portion 26 of upper 12. Internal heel counter 34 then gradually descends to a position below aft billows 30 at the rear of the heel portion of upper 12 and above external heel counter 20. Thus, internal heel counter 34 is cantilevered upwardly from external heel counter 20 except that it has outer shell 44 placed therebetween in the preferred embodiment.

[0045] FIG. 2 further illustrates the heel counter/internal cuff construction. The right and left sides of internal heel counter 34 are substantially the same except for variations due to differences in the anatomical shapes and movements between the medial and lateral sides of the skater's feet. The uppermost portion of both sides of internal heel counter 34 includes recesses with arcuate lower boundaries. The bottom of the recesses preferably includes grooves 40 into which an ankle cuff 36 is engaged with a tongue and groove configuration. Pivot pins 38 are secured at the radial centers of the arcuate portions and extend between ankle cuff 36 and internal heel counter 34. Preferably, pivot pins 38 are rivets. Pivot pins 38 allow fore and aft movement of ankle cuff 36 relative to internal heel counter 34. Pivot pins 38 restrict lateral and medial flex of ankle cuff 36. Ankle cuff 36 is constructed of a rigid material such as plastic or fiber-reinforced plastic. The material is rigid relative to the softer portions of upper 12 that surround most of the rest of the foot of the skater. Ankle cuff 36 is preferably U-shaped as viewed from above such that it surrounds the lower leg of the skater and ankle of the skater from behind toward the front of the skate. Ankle cuff 36 preferably does not entirely surround the ankle or lower leg of the skater but preferably extends in front of the ankle bones. Thus, ankle cuff 36 provides medial

and lateral support to the skater's ankle while allowing fore and aft flex about pivot pin 38. Ankle portion 26 of upper 12 is able to flex fore and aft with ankle cuff 36 since it is secured therearound and is of a softer, more flexible material than ankle cuff 36. Thereby, with the above described construction, a skate is provided that has the pleasing aesthetic appearance of a sport shoe or hiking boot with superior medial and lateral support and fore and aft flexibility that are required for in-line skating.

[0046] The arrangement of pivot pin 38 and groove 40 with a cuff tongue 42 (as illustrated in FIGS. 3 and 4) provides a strong and supportive interconnection between ankle cuff 36 and internal heel counter 34. Both medial and lateral flex are restricted by both sides of ankle cuff 36 with this arrangement since there is a vertical space between pivot pin 38 and the tongue and groove arrangement.

[0047] FIG. 3 further illustrates the details of the layering of upper 12. As discussed above, a cuff tongue 42 extends downwardly from cuff 36 to interface with groove 40 of heel counter 34. Thus, a sliding arrangement exists between cuff 36 and heel counter 34 at the interface between the two with a semicircular tongue and groove interface. The portion of internal heel counter 34 that extends above pivot pin 38 is preferably on the outside of ankle cuff 36 to provide additional support when any portion of cuff 36 is pushed outwardly in a medial or lateral direction.

[0048] As seen in FIGS. 3 and 4, upper 12 includes the outer shell 44 mentioned above substantially encompassing the majority of upper 12. Outer layer or shell 44 is preferably constructed of a leather or flexible man-made materials. Outer shell 44 is secured to base 18, toe cap 22, and external heel counter 20. Outer shell 44 extends to the top of upper 12 where it is preferably joined to an inner lining 46. Inner lining 46 lines the interior walls of upper 12. Inner lining 46 is preferably a breathable material such as a tricot or other conventional breathable lining. A soft padding 48 is secured between inner lining 46 and ankle cuff 36 and internal heel counter 36 and 34. Padding 48 also preferably extends between inner lining 46 and outer shell 44 in areas that do not include heel counter 34 and ankle cuff 36. Padding 48 is preferably a conventional padding such as an open-cell foam material.

[0049] FIG. 3 also illustrates skate tongue 50 extending in a conventional manner in front portion of upper 12.

[0050] A last board 52 permanently secures the above-described portions of upper 12 to base 18. Preferably, rivets or other fasteners extend through frame 14, base 18, and last board 52. Adhesives are also used. Outer shell 44 as well as internal heel counter 34 extend at least partially beneath last board 52 and base 18. The secure connection of upper 12 to base 18 provides a skate that is superior in performance to any skates that include removable liners since the foot of the skater can be more securely held within the skate and to the base and frame. An insole 54 is placed over last board 52 within skate upper 12.

[0051] Turning now to FIGS. 5-13, alternate embodiments of the invention will now be discussed. In the figures, most details of the uppers are not illustrated to more clearly depict the arrangement of the cuffs and heel counters. Also note that the last two digits of each numbered element correspond to like-numbered elements in previous embodiments.

[0052] FIG. 5 illustrates an alternate embodiment of the present invention. Note that like reference numbers are used throughout FIG. 5 except that the number 100 has been added to each. Internal heel counter 134 is connected to internal cuff 136 by a pivot neck 138. Pivot neck 138 is small enough so as to create a "live hinge" between cuff 136 and heel counter 134. In this embodiment, cuff 136 may either be in the form of side panels within the sides of upper 112 or may extend around the back of the skate in a generally U-shaped configuration. The details of most of upper 112 are not illustrated in FIG. 5 so as to more clearly represent internal heel counter 134, pivot neck 138, and internal cuff 136. The remaining details are similar to those disclosed above in connection with FIGS. 1 through 4. Movement of internal cuff 136 is also shown in phantom lines in FIG. 5. With cuff 136 having a U-shaped configuration, the structural integrity to provide medial and lateral support to the ankle of the skater is provided in a simple, low-cost, integral construction with internal heel counter 134 while fore and aft pivoting motion is still allowed.

[0053] Referring now to FIG. 6, an embodiment of the present invention with an internal cuff 236 interfacing with an internal heel counter 234 does not include a pivot pin at the center of the radius of curvature of the interface. In this embodiment, internal cuff 236 is interconnected with internal heel counter 234 by a tongue and groove arrangement as discussed above. However, forward and rearward arms 258 and 260 bias cuff 236 to a neutral position and hold cuff 236 within groove 240. Forward and rearward arms 258 and 260 form a "V" shape with the bottoms of the arms being connected to a heel counter pin secured between the arms and internal heel counter 234 beneath the lowest portion of groove 240. Alternatively, groove 240 may simply be a recess on the sides of internal heel counter 234. The upper ends of arms 258 and 260 are secured to guide holes 262 within heel counter 234 by guide pins 264. Guide pins 264 slide within arcuate guide holes 262 and hold the sides of cuff 236 against heel counter 234. Arms 258 and 260 may be on the interior or exterior of internal heel counter 234. Arms 258 and 260 are preferably constructed from a tough elastomeric material. The remaining details of the embodiment illustrated in FIG. 6 are similar to the embodiments discussed above.

[0054] Referring now to FIG. 7, another alternate embodiment similar to that of FIG. 6 will be described. In this embodiment, a single elastomeric arm 358 is fixedly secured on both ends in a horizontal fashion to internal heel counter 334. Arm 358 is secured across the lower portion of the recess in internal heel counter 334 with the lowermost part of cuff 336 disposed between arm 358 and heel counter 334. Arm 358 is elastic in nature and flexible to permit fore and aft movement of cuff 336 relative to internal heel counter 334. Depending on the elasticity of arm 358, the lower arcuate edge of heel counter 336 may rocker inside the recess created within the top of heel counter 334, thus pulling somewhat upwardly with guide pin 364 on arm 358. The recess within the top of heel counter 334 may have a greater radius of curvature so as to permit such rockering.

[0055] Another embodiment will now be discussed in connection with FIG. 8. This embodiment is similar to that of FIGS. 6 and 7 discussed above. In this embodiment, a flex cross 438 is interconnected between cuff 436 and internal heel counter 434. The upper arm 462 of flex cross

438 is secured to cuff 436 although, alternatively, multiple arms may be connected to cuff 436 with one or more multiple arms connected to internal heel counter 434. Again, cuff arm 462 and heel counter 458 are connected at their ends to cuff 436 and heel counter 434, respectively. Thus, the elastic nature of flex cross 438 allows movement of cuff 436 relative to heel counter 434 with either rockering or pivoting sliding action between the arcuate portions of each.

[0056] Referring now to FIG. 9, another alternate embodiment, includes reversed arcuate portions of the heel counter 534 and cuff 536 such that cuff 536 includes a concave portion while heel counter 534 contains convex portions. In this case, heel counter 534 may extend upwardly to just above the ankle bones of the skater. Cuff 536 permits movement of the lower leg of the skater relative to internal heel counter 534. Either a recess or a groove 540 with a cuff tongue 542 interfaces between the two elements.

[0057] Referring now to FIG. 10, an embodiment is shown wherein no positive pivotal or linkage connection is created between a cuff 636 and a heel counter 634 other than a tongue and recess or tongue and groove arrangement. The fact that cuff 636 and internal heel counter 634 are held within outer shell 44 of upper 612 provides enough retention of the elements such that no rivet or other fastening means is necessary.

[0058] FIG. 11 illustrates another alternate embodiment of the invention wherein a recess 740 in the top of the internal heel counter 734 is provided to overlap cuff 736. However, in this embodiment, a guide hole 762 in the form of an elongate arcuate slot is provided in the bottom of cuff 736 adjacent a recessed portion 740 of internal heel counter 734. A heel counter pin 756 extends through recess portion 740 and through guide hole 762 to restrict the movement of cuff 736 and provide additional strength thereto.

[0059] A slight rearrangement of this construction is shown in FIG. 12. In FIG. 12, the same guide pin/guide hole arrangement is utilized except that a groove 840 is provided in the bottom of the recess into which a cuff tongue 842 extends. In this embodiment, cuff 836 is further restricted and strengthened from medial and lateral movement since cuff tongue 842 cannot move laterally or medially but only slide within groove 840. Note that the actual pivot axis of cuff 836 may be above heel counter pin 856 due to guide hole 862 being arcuate and providing room for movement. Thus, the pivot axis may be at the ankle bones (malleoli) of the skater without having a rivet or pin projecting inwardly at that same location.

[0060] Referring now to FIG. 13, an additional element will be described relating to the external portion of upper 912. In this embodiment, full billows 966 are provided between ankle portion 926 and forefoot portion 924 to allow the two portions as well as cuff 936 and internal heel counter 934 to move relative to each other. Billows 966 is an elastic rubbery material that is easily flexible without breaking down. In this embodiment, full billows 966 extends from the front of the boot down below the ankle bone to above the heel behind the ankle bone in an arcuate fashion. Billows 966 would then extend around the rear of the skate to a substantially mirror configuration on the other side of the skate.

[0061] Referring to FIG. 14, additional support structures preferably added to the basic structure described above

relative to **FIGS. 1 through 4** will now be discussed. In **FIG. 14**, the entire soft portion of upper **12** has been removed to expose last board **1052**, internal heel counter **1034**, and internal cuff **1036**. The construction of these three elements and arrangement in **FIG. 14** are substantially similar to that discussed above with regard to **FIGS. 1 through 4**. However, outer supports **1068** and inner supports **1070** have also been added to provide a smooth transition between these elements and for greater support and comfort. Outer supports **1068** are constructed of a plastic material and overlay the cuff and heel counter intersection of the skate and extend slightly forwardly therefrom. This provides additional rigidity to the pivotal and tongue and groove arrangement of the support structure and wraps around the foot of the skater to provide additional support. Likewise, inner supports **1070** cover the intersection between cuff **1036** and heel counter **1034** on the inside of these elements and also cover the inside of pivot pin **1038**, which may be a rivet or other fastener. Thus, inner supports **1070** not only provide additional structural support for the foot of the skater to help maintain the proper orientation of the in-line skate, but also provide smooth transition between the elements for maximum comfort. Supports **1068** and **1070** are fixedly secured to internal heel counter **1034**. Supports **1068** and **1070** are slidably secured to internal cuff **1036** such that they nest against cuff **1036** so as to not hinder the movement thereof in the fore and aft directions. However, supports **1068** and **1070** further strengthen cuff **1036** in the lateral and medial directions and provide further support around the foot of the skater beyond that provided by heel counter **1034**.

[0062] While the preferred embodiments of the invention have been illustrated and described, it will be appreciated that various changes can be made therein without departing from the spirit and scope of the invention. The basic concepts and constructions disclosed could be modified such as by placing them on the exterior of the skate on the outside of outer shell **44** or by changing the arrangement in any number of ways while still maintaining basic concepts of having the rigid cuff interconnected to the heel counter in a pivotal fashion.

[0063] A further embodiment of the present invention showing one such alternate construction is illustrated in **FIGS. 15-18**. The skate **1110** illustrated in **FIG. 15** is constructed similarly to the skate **10** of **FIG. 1**, with the exception of the construction and mounting of the pivotal ankle support cuff. Thus, those details of the embodiment of **FIGS. 15-18** in common with those of **FIG. 1** will not be described in great detail. Generally, the skate **1110** includes an upper **1112** that is connected to a frame **1114** between the sidewalls of which are rotatably secured a plurality of wheels **1116**. The upper **1112** includes a rigid base **1118**, the underside of which is secured the frame **1114**. Securement of the base **1118** to the frame **1114** may be by riveting, threaded fasteners, adhesion, or other manners, as previously described, or the base **1118** and the frame **1114** may be integrally formed. In the embodiment illustrated, the base **1118** is rigid the full length of the upper **1112** from the forward toe end to the rear heel end of the base. However, it should be understood that the present invention also applies equally well to a skate that may include a flexing base **1118** having either a heel end that is unsecured to and able to lift away from the rear end of the frame, or including a split frame having front and rear segments.

[0064] The upper **1112** also includes a substantially nonrigid upper portion **1120** that receives and surrounds the foot of a skater. The nonrigid upper portion **1120** runs from a forward, toe end **1122** of the base **1118** to a rear, heel end **1124** of the base **1118**. The nonrigid upper portion **1120** is formed from flexible materials, as previously described, such as leather, canvas, nylon fabric, or flexible plastic. The forward end of the nonrigid upper **1120** is protected by a toe guard **1126** formed of a rigid or substantially rigid plastic material. The toe guard is secured to the edge of the toe end **1122** of the base **1118**, and rises outwardly therefrom to wrap the sides and upper edge of the toe portion of the substantially nonrigid upper portion **1120**. The nonrigid upper portion **1120** also includes a vamp opening **1128** that overlaps a tongue **1130** secured at the forwardmost end of the vamp opening **1128**, and selectively closed by a fastener such as a lace **1132**.

[0065] The nonrigid upper portion **1120** is internally reinforced by an internal heel counter **1134**. Referring to **FIGS. 15 and 16**, the internal heel counter **1134** has a generally U-shaped configuration and is secured about a lower U-shaped edge thereof to the perimeter of the heel end **1124** of the base **1118**. The internal heel counter **1134** rises upwardly from the base **1118**, and wraps the rear and lateral and medial sides of the heel of a skater. The heel counter **1134** terminates below the malleoli, or ankle bones, of the skater, and extends forwardly to the beginning of the instep of the skater's foot. While the internal heel counter **1134** is received within and covered by the substantially nonrigid upper **1120**, portions of the internal heel counter **1134** may be exposed for aesthetic reasons. In the illustrated embodiment, lateral and medial (not shown) apertures **1136** are defined in the nonrigid upper portion **1120**, to expose an underlying portion of the internal heel counter **1134**.

[0066] The internal heel counter **1134** has a substantially rigid construction and may be suitably formed of a rigid or substantially rigid plastic or metal. In the embodiment illustrated, the internal heel counter **1134** is formed from a fiber-reinforced resin such as a graphite fiber reinforced polyester resin composite. The nonrigid upper portion **1120** extends to cover and protect the full height of the internal heel counter **1134**, except for the exposed portion of the heel counter at the apertures **1136**. The nonrigid upper portion **1120** terminates below the malleoli of the user, with the exception of the tongue **1130**, which extends upwardly along the front side of the ankle, as best shown in **FIG. 16**. The upper **1112**, formed of the nonrigid upper portion **1120**, reinforced by the internal heel counter **1134**, and the base **1118** thus do not in any way restrict pivoting or flexing of the user's ankle.

[0067] In order to support the user's ankle in the lateral and medial directions while enabling flexure of the ankle to a predetermined extent in the forward and rearward direction that is unrestricted by the nonrigid upper portion, the skate of **FIGS. 15-17** includes an independent ankle support cuff assembly **1140**. The ankle support cuff assembly **1140** includes a substantially rigid ankle support cuff **1142**, an internal ankle pad **1144** (**FIGS. 16 and 17**), a partial external ankle shell **1146**, and a selectively securable fastener **1148**.

[0068] The ankle cuff **1142** has a rigid or substantially rigid construction. The external ankle cuff **1142** has a generally U-shaped configuration defining lateral and



medial sides that each terminates at a lower end in pivot extensions **1152**. The cuff **1142** is contoured so that it wraps around and supports the rear side of the ankle and extends over the malleoli, including concave portions to accommodate the malleoli protrusions of a skater's ankle. The pivot extensions **1152** extend downwardly below the malleoli, and are pivotally secured by rivets **1150** to the lateral and medial sides of the heel counter **1134**. The pivotal connection provided at the rivets **1150** is horizontally aligned with but slightly below the pivot axis of the ankle. The ankle support cuff **1142** can be constructed from similar materials as described above for the internal heel counter **1134**.

[**0069**] The ankle pad **1144** wraps about the user's ankle and extends downwardly inside the ankle support cuff **1142**. The ankle pad **1144** is formed from a soft cushioning material, such as an elastomeric foam. The ankle pad **1144** is larger than the ankle support cuff **1142**, extending further upwardly, forwardly, and downwardly than the ankle support cuff **1142**. When combined with the tongue **1130**, the ankle pad **1144** completely wraps the user's ankle. The pad **1144** projects downwardly into the interior of the upper **1112**, defining a lower edge that terminates just above an insole **1160**. However, the pad **1144** is not connected to or secured to the internal heel counter **1134** or the upper **1120**, but rather is independent thereof. The ankle pad **1144** is lined with a fabric sheet **1162**, which extends over the inner surface of the pad **1144** and wraps downwardly and over the outer surface of the pad **1144**. In a preferred embodiment, the fabric sheet **1162** extends further downwardly over an upper edge of the ankle support cuff **1142**. The fabric **1162** forms a portion of the exterior shell **1146** of the ankle cuff. The exterior shell **1146** is finished by the securable fastener, such as a strap with a hook-and-loop closure, that surrounds the forward side of the ankle, crossing in front of the tongue **1130** to fasten the ankle cuff assembly about the user's lower leg, just above the ankle. The ankle cuff assembly **1140**, consisting of the cuff **1142**, pad **1144**, shell **1146**, and strap **1148**, is coupled to the upper **1112** only through pivotal connection of the cuff **1142** to the internal heel counter **1134** at the pivot points defined by the rivets **1150**, except that the tongue **1130** extends upwardly into the cuff. This enables the user to freely flex the ankle, pivoting the ankle support cuff assembly **1110** relative to the heel counter **1134** freely and without resistance, in the fore and aft direction.

[**0070**] A gap is defined between the partial ankle shell **1146** and the nonrigid upper **1120**. While a lateral and medial rivet pivot is disclosed, other pivoting constructions, such as those described above, may be utilized, including a flexible linkage between the upper and lower portions of an integrated cuff and heel counter assembly, or a bellows linkage. The lower edge of the internal heel counter **1134** may be secured to the base **1118** by any of the methods disclosed above, such as sewing, adhesion, or riveting. Likewise, the ankle pad **1144** and partial ankle shell **1146** may be adhered to the ankle cuff **1142** by various methods known to those in shoe construction, such as by stitching, as is preferred, or by adhesion.

[**0071**] These and various other alterations and variations to the disclosed embodiments may be made, all within the scope of the present invention. For example, while an in-line skate has been disclosed, ice skates are also within the scope of the present invention. It is thus intended that the scope of

the invention be defined by the claims dependent hereto, and not by the disclosed embodiments.

[**0072**] While the preferred embodiment of the invention has been illustrated and described, it will be appreciated that various changes can be made therein without departing from the spirit and scope of the invention.

The embodiments of the invention in which an exclusive property or privilege is claimed are defined as follows:

**1.** An in-line skate comprising:

a frame rotatably supporting a plurality of in-line wheels;

a shoe portion comprising a base secured to the frame and a nonrigid upper portion secured to the base;

a rigid heel counter secured to the base and disposed between an outer layer of the nonrigid upper portion and an inner lining;

an ankle support assembly including a rigid ankle cuff covered by a flexible shell, the rigid ankle cuff having oppositely-disposed pivot extensions that are pivotably attached to the heel counter such that the ankle support assembly is pivotable about a transverse axis substantially independently of the shoe portion, and a U-shaped portion adapted to wrap about the skater's ankle; and

wherein the inner lining overlies an inner surface of the rigid ankle cuff.

**2.** The skate of claim 1, wherein the rigid ankle cuff includes concave portions adapted to accommodate the malleoli protrusions of a skater's ankle.

**3.** The skate of claim 1, wherein the inner lining is not secured to the rigid heel counter.

**4.** The skate of claim 1, wherein the inner lining is a lined foam pad.

**5.** The skate of claim 1, wherein the ankle support assembly further comprises a securable closure strap.

**6.** The skate of claim 1, wherein the shoe portion further comprises a tongue that extends upwardly from the upper portion and is engaged by the ankle support assembly.

**7.** The skate of claim 1, wherein a gap is defined between a lower rear edge of the ankle support assembly and an upper rear edge of the nonrigid upper portion.

**8.** The skate of claim 1, wherein at least a portion of the rigid ankle cuff is exposed between the flexible shell and the nonrigid upper portion.

**9.** The skate of claim 1, further comprising a rigid toe guard secured to the base and overlying a toe portion of the nonrigid upper portion.

**10.** The skate of claim 1, wherein the nonrigid upper portion comprises a breathable fabric.

**11.** A skate comprising:

a frame rotatably supporting a plurality of wheels;

a base secured to the frame;

a nonrigid upper portion secured to the base and formed from flexible materials;

a rigid heel counter secured to the base and disposed between an outer layer of the nonrigid upper portion and an inner lining layer; and

an ankle support assembly comprising a rigid ankle cuff defining lateral and medial arms that pivotably attach to

the rigid heel counter and a U-shaped portion extending above the nonrigid upper portion, and a securable nonrigid shell disposed over an outer surface of the rigid ankle cuff;

wherein the ankle support assembly is constrained to pivot about an axis transverse to a longitudinal axis defined by the base.

12. The skate of claim 11, wherein the rigid ankle cuff includes concave portions adapted to accommodate the malleoli protrusions of a skater's ankle.

13. The skate of claim 11, wherein the inner lining layer is a lined foam pad.

14. The skate of claim 11, wherein the nonrigid upper portion further comprises a tongue portion that extends upwardly to engage the ankle support assembly.

15. The skate of claim 11, further comprising a rigid toe guard secured to the base and overlying a toe portion of the nonrigid upper portion.

16. The skate of claim 11, wherein the nonrigid upper portion comprises a breathable fabric.

17. A skate having a plurality of wheels, a base defining an upper surface, a lower surface and a longitudinal axis, a

frame secured to the base for mounting the plurality of wheels, and a nonrigid upper portion adapted to receive a skater's foot and secured to the base, the nonrigid upper portion extending upwardly from the base and adapted to terminate below the ankle of the received skater's foot, the improvement comprising:

a rigid heel counter secured to the base and disposed between an outer layer of the nonrigid upper portion and an inner foam layer and an ankle support assembly pivotally connected to the internal heel counter, the rigid ankle support assembly comprising a rigid ankle cuff support and a nonrigid shell portion covering an outer surface of the rigid ankle cuff support.

18. The skate of claim 17, wherein the rigid ankle cuff includes a C-shaped portion and oppositely-disposed pivot extensions that are pivotably attached to the heel counter.

19. The skate of claim 18, wherein the oppositely-disposed pivot extensions include concave portions adapted to accommodate the malleoli protrusions of a skater's ankle.

\* \* \* \* \*