

B. C. LOW.
STIRRER OR MIXER.
APPLICATION FILED OCT. 21, 1920.

1,410,199.

Patented Mar. 21, 1922.

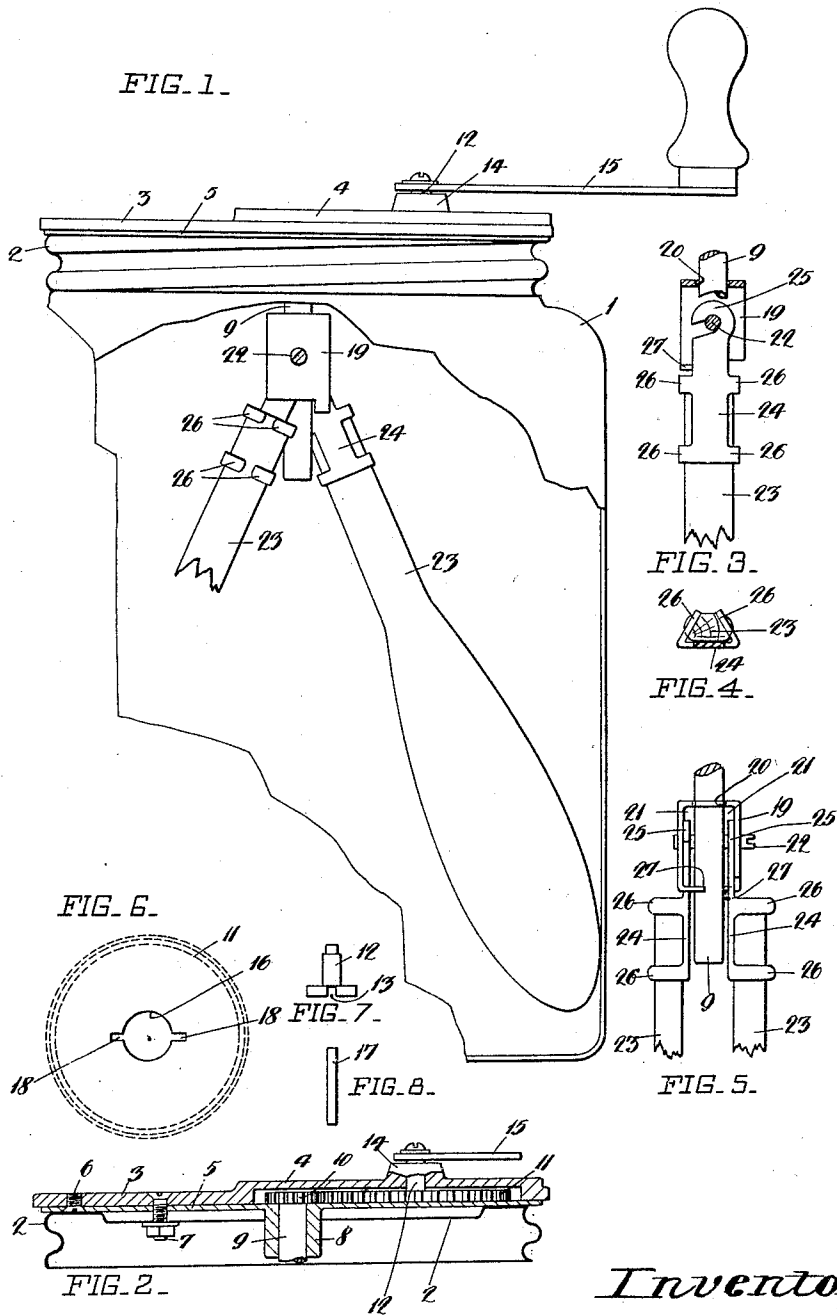

Inventor
B. C. LOW
By H. R. Kerlake,
Attorney

UNITED STATES PATENT OFFICE.

BASIL CARLISLE LOW, OF AUCKLAND, NEW ZEALAND.

STIRRER OR MIXER.

1,410,199.

Specification of Letters Patent. Patented Mar. 21, 1922.

Application filed October 21, 1920. Serial No. 418,404.

To all whom it may concern:

Be it known that BASIL CARLISLE LOW, a citizen of the Dominion of New Zealand, residing at Hellaby's Building, Queen Street, Auckland, New Zealand, has invented certain new and useful Improvements in Stirrers or Mixers, of which the following is a specification.

This invention relates to apparatus fitted to the covers or lids of vessels or containers, and operated for the purpose of stirring or mixing the contents thereof, and its object is to provide improved means for the aforesaid purpose.

According to the invention two plates secured together are fitted on the cover or lid of a vessel or container and between said plates a pinion and driving wheel are located, the pinion being mounted on the upper end of a short central shaft passing through the lower plate and said cover or lid, and with said driving wheel is housed in a raised portion of the upper plate.

A crank handle is fitted on the upper end of a spindle which passes upwards through the upper plate and is slotted at its lower end to fit over a pin accommodated in grooves and so as to lay across the central opening of the driving wheel.

A metal strip bent to provide parallel sides and a connecting portion is passed on the central shaft below the cover or lid, and is secured to said shaft by a cross pin, so that spaces are left between the parallel sides of the strip and said shaft.

Beaters or blades with hooks at their upper ends are pivotally secured to the central shaft by being hung on the cross pin, in the spaces between the shaft and the sides of the strip, at opposite sides of the shaft. When the latter is rotated by means of the driving gear, said beaters or blades are caused to revolve and open out in the container, whereupon the contents of the latter are thoroughly agitated and stirred.

Stops on the strip sides limit the opening of the beaters or blades to one way only.

The invention will be further described, with reference to the accompanying drawing in which:—

Figure 1 is an elevation (broken) of a container, showing the apparatus fitted to the cover thereof.

Figure 2 is a cross sectional view of the cover and apparatus fitted thereto.

Figure 3 is a vertical part section showing the mounting of the beaters or blades.

Figure 4 is a cross section of the upper end of a beater or blade.

Figure 5 is a further view in elevation illustrating the mounting, of the beaters or blades, and at right angles to Figure 3.

Figures 6, 7 and 8 are detail views of the driving wheel and parts fitted thereto.

In the drawing 1 represents a vessel or container, and 2 the cover or top thereof which in this case is a screw on top.

The upper plate 3 is provided with a raised portion 4 and is secured to the lower plate 5 by screws 6, both plates being secured to the cover 2 by screws and nuts 7.

The lower plate 5 is provided with a boss 8 on its under side, which projects downwards through the cover 2. The short central shaft 9 passes through the lower plate 5 and boss 8 thereof below the latter and also projects above the former, but does not pass through the upper plate 3.

The pinion 10 is keyed on the upper end of the shaft 9, and gears with the toothed driving wheel 11, which with said pinion 10 is housed in the raised portion 4 of said plate 3.

A spindle 12 the base of which contains a cross groove 13 extends upwards through the boss 14 of the upper plate 3 and has a crank handle 15 mounted on its upper end.

The base of the spindle 12 fits into the central opening 16 of the wheel 11, the groove 13 fitting over the pin 17 which lays in grooves 18 in the wheel 11 so as to cross the opening 16.

The metal strip 19 is bent so as to have parallel sides and a connecting portion, the latter containing a central hole 20 which enables said strip to be passed on the shaft 9 below the cover 2, the distance between the sides of the strip being such that spaces 21 are left between the strip sides and the shaft 9.

The strip 19 is secured on the shaft 9 by a cross pin 22 which passes through the strip sides and the shaft 9 and screws into one of the former. The beaters or blades 23 are made preferably of wood and gradually widen towards their lower ends where they are rounded off.

The small or upper ends of the beaters or blades 23 have secured thereon plates 24 which terminate at their upper ends in hooks

25 said plates being secured to the beater or blade ends preferably by having fingers or strips 26 which are bent around the beater or blade ends.

5 The beaters or blades 23 are pivotally secured one at each side of the shaft 9, by engaging the hooks 25 on the cross pin 22, in the spaces 21 between the sides of the strip 19 and shaft 9.

10 The beaters or blades 23 when revolved about the shaft 9 within the container or vessel 1, by turning the handle 15, naturally tend to open or move outwards from each other so that the distance between said beaters or blades is determined by the speed at
15 which the handle 15 is driven.

The person using the apparatus is thereby enabled to operate the beaters or blades, to act in or agitate the contents of the vessel
20 or container, near the centre thereof or at any distance from the centre according to requirements.

The beaters or blades 23 extend nearly to the bottom of the container or vessel and are
25 limited by stops 27 on the lower ends of the sides of the strip 19 to opening from each other in the one direction.

Having now particularly described and as-

certained the nature of my said invention and in what manner the same is to be per- 30 formed I declare that what I claim is:—

1. In an agitating device, a rotatable shaft, an inverted U-shaped member having its crosshead arranged on said shaft, a cross pin carried by the shaft and extending through 35 the legs of said U-shaped member, and blades having extensions pivotally mounted on said pin and arranged between the shaft and said legs.

2. In a device of the kind defined by claim 40 1, clamping members mounted on said extensions and gripping said blades.

3. A device of the kind defined by claim 1 in which said extensions are provided with hooks which pivotally engage said cross pin. 45

4. In a device of the kind defined by claim 1, stops provided on the legs of said U-shaped member and functioning to restrict the piv-
otal movement of said blades.

In testimony whereof I have affixed my 50 signature in the presence of two witnesses.

BASIL CARLISLE LOW.

Witnesses:

WILLIAM PINCHES,
MARY PILKINGTON.