

(19) World Intellectual Property
Organization
International Bureau



(43) International Publication Date
25 March 2004 (25.03.2004)

PCT

(10) International Publication Number
WO 2004/024193 A3

(51) International Patent Classification⁷: A61F 13/20

(21) International Application Number:
PCT/US2003/028181

(22) International Filing Date:
10 September 2003 (10.09.2003)

(25) Filing Language: English

(26) Publication Language: English

(30) Priority Data:
10/242,474 12 September 2002 (12.09.2002) US

(71) Applicant: **PLAYTEX PRODUCTS, INC.** [US/US]; 300
Nyala Farms Road, Westport, CT 06880 (US).

(72) Inventors: **LEMAY, Jessica, E.**; 106 Highland Boule-
vard, Apt A., New Castle, DE 19720 (US). **BENNETT,
Kathryn, G.**; 103 Flora Boulevard, Fairfield, CT 06430
(US). **EDGETT, Keith, J.**; 2 Rosewood Court, Ramsey,

NJ 07423 (US). **JACKSON, Dane, R.**; 18 Leary Avenue,
Bloomingdale, NJ 07403 (US). **TURCHI, Mario, A.**; 168
Serpentine Road, Tenafly, NJ 07670 (US). **WEBER, Su-
sanne**; 22 Catherine Street #7F, New York, NY 10038
(US).

(74) Agent: **RUGGIERO, Charles, N., J.**; Ohlandt, Gree-
ley, Ruggiero & Perle, L.L.P., 10th Floor, One Landmark
Square, Stamford, CT 06901 (US).

(81) Designated States (*national*): AE, AG, AL, AM, AT, AU,
AZ, BA, BB, BG, BR, BY, BZ, CA, CH, CN, CO, CR, CU,
CZ, DE, DK, DM, DZ, EC, EE, ES, FI, GB, GD, GE, GH,
GM, HR, HU, ID, IL, IN, IS, JP, KE, KG, KP, KR, KZ, LC,
LK, LR, LS, LT, LU, LV, MA, MD, MG, MK, MN, MW,
MX, MZ, NI, NO, NZ, OM, PG, PH, PL, PT, RO, RU, SC,
SD, SE, SG, SK, SL, SY, TJ, TM, TN, TR, TT, TZ, UA,
UG, UZ, VC, VN, YU, ZA, ZM, ZW.

(84) Designated States (*regional*): ARIPO patent (GH, GM,
KE, LS, MW, MZ, SD, SL, SZ, TZ, UG, ZM, ZW),
Eurasian patent (AM, AZ, BY, KG, KZ, MD, RU, TJ, TM),
European patent (AT, BE, BG, CH, CY, CZ, DE, DK, EE,
ES, FI, FR, GB, GR, HU, IE, IT, LU, MC, NL, PT, RO,

[Continued on next page]

(54) Title: ERGONOMIC TAMPON APPLICATOR

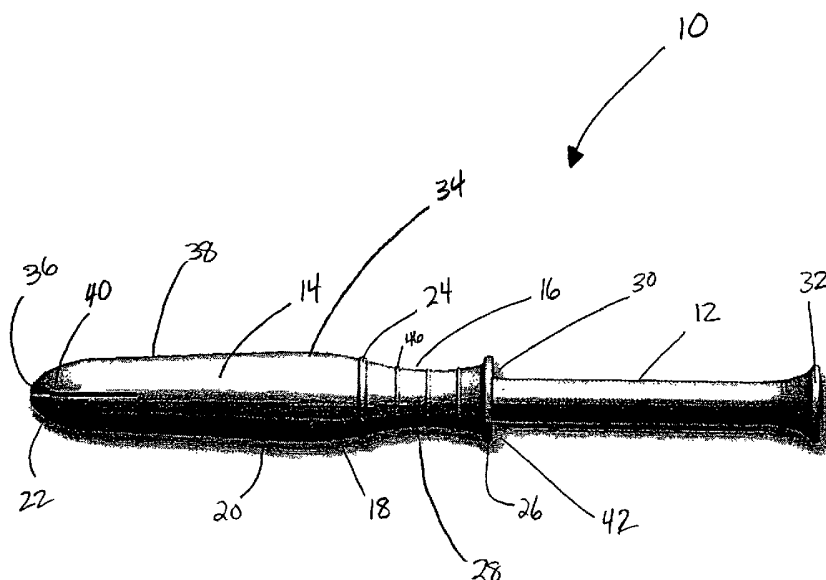

(57) Abstract: The present invention is directed to an ergonomically improved tampon applicator having a plunger (12) and a barrel (14). The barrel has four distinct sections, namely a finger grip section (16), a reverse taper section (18), a main body section (20), and an insertion tip section (22). The reverse taper section is tapered towards the finger grip section and the main body section is tapered in an opposite direction towards the insertion tip section. A maximum diameter is formed where the reverse taper section and main body section meet on the barrel. The maximum diameter provides a sensory means to the user to alert the user when the applicator has been inserted at the proper depth in the vagina.

WO 2004/024193 A3



SE, SI, SK, TR), OAPI patent (BF, BJ, CF, CG, CI, CM, GA, GN, GQ, GW, ML, MR, NE, SN, TD, TG).

For two-letter codes and other abbreviations, refer to the "Guidance Notes on Codes and Abbreviations" appearing at the beginning of each regular issue of the PCT Gazette.

Published:

- *with international search report*
- *before the expiration of the time limit for amending the claims and to be republished in the event of receipt of amendments*

(88) Date of publication of the international search report:

15 July 2004

INTERNATIONAL SEARCH REPORT

International application No.

PCT/US03/28181

A. CLASSIFICATION OF SUBJECT MATTER

IPC(7) : A61 F 13/20
 US CL : 604/904,385.17,385.18

According to International Patent Classification (IPC) or to both national classification and IPC

B. FIELDS SEARCHED

Minimum documentation searched (classification system followed by classification symbols)
 U.S. : 604/904,385.17,385.18

Documentation searched other than minimum documentation to the extent that such documents are included in the fields searched

Electronic data base consulted during the international search (name of data base and, where practicable, search terms used)

C. DOCUMENTS CONSIDERED TO BE RELEVANT

Category *	Citation of document, with indication, where appropriate, of the relevant passages	Relevant to claim No.
X --- Y	US Des. 250, 663 A (Koch et al) 26 December 1978 (26.12.1978), See entire document.	1-4,7-9,12-24,37-39 ----- 5,6,10,11,25,26,29,30, 33
X	US 3,628,533 A (Loyer) 21 December 1971 (21.12.1971) See figures 1 and 3 and col. 1, lines 18-25,	1, 27, 31, 32, and 34
Y	US 4,536,178 A (Lichstein et al.) 20 August 1985 (20.08.1985), See col. 5, lines 7-11 and figures.	28, 29
Y	US 4,508,531 A (Whitehead) 02 April 1985 (02.04.1985) See col. 2, lines 11-33 and col. 3, lines 3-9.	35,36

Further documents are listed in the continuation of Box C.

See patent family annex.

* Special categories of cited documents:	
"A" document defining the general state of the art which is not considered to be of particular relevance	"T" later document published after the international filing date or priority date and not in conflict with the application but cited to understand the principle or theory underlying the invention
"E" earlier application or patent published on or after the international filing date	"X" document of particular relevance; the claimed invention cannot be considered novel or cannot be considered to involve an inventive step when the document is taken alone
"L" document which may throw doubts on priority claim(s) or which is cited to establish the publication date of another citation or other special reason (as specified)	"Y" document of particular relevance; the claimed invention cannot be considered to involve an inventive step when the document is combined with one or more other such documents, such combination being obvious to a person skilled in the art
"O" document referring to an oral disclosure, use, exhibition or other means	"&" document member of the same patent family
"P" document published prior to the international filing date but later than the priority date claimed	

Date of the actual completion of the international search

22 March 2004 (22.03.2004)

Date of mailing of the international search report

11 MAY 2004

Name and mailing address of the ISA/US

Mail Stop PCT, Attn: ISA/US
 Commissioner for Patents
 P.O. Box 1450
 Alexandria, Virginia 22313-1450

Facsimile No. (703) 305-3230

Authorized officer

John Calvert

Telephone No. (703) 308-0858