

No. 666,597.

Patented Jan. 22, 1901.

S. G. BRIDGES.
APPARATUS FOR TREATING ZINC ORES.

(Application filed Nov. 5, 1900.)

(No Model.)

2 Sheets—Sheet 2.

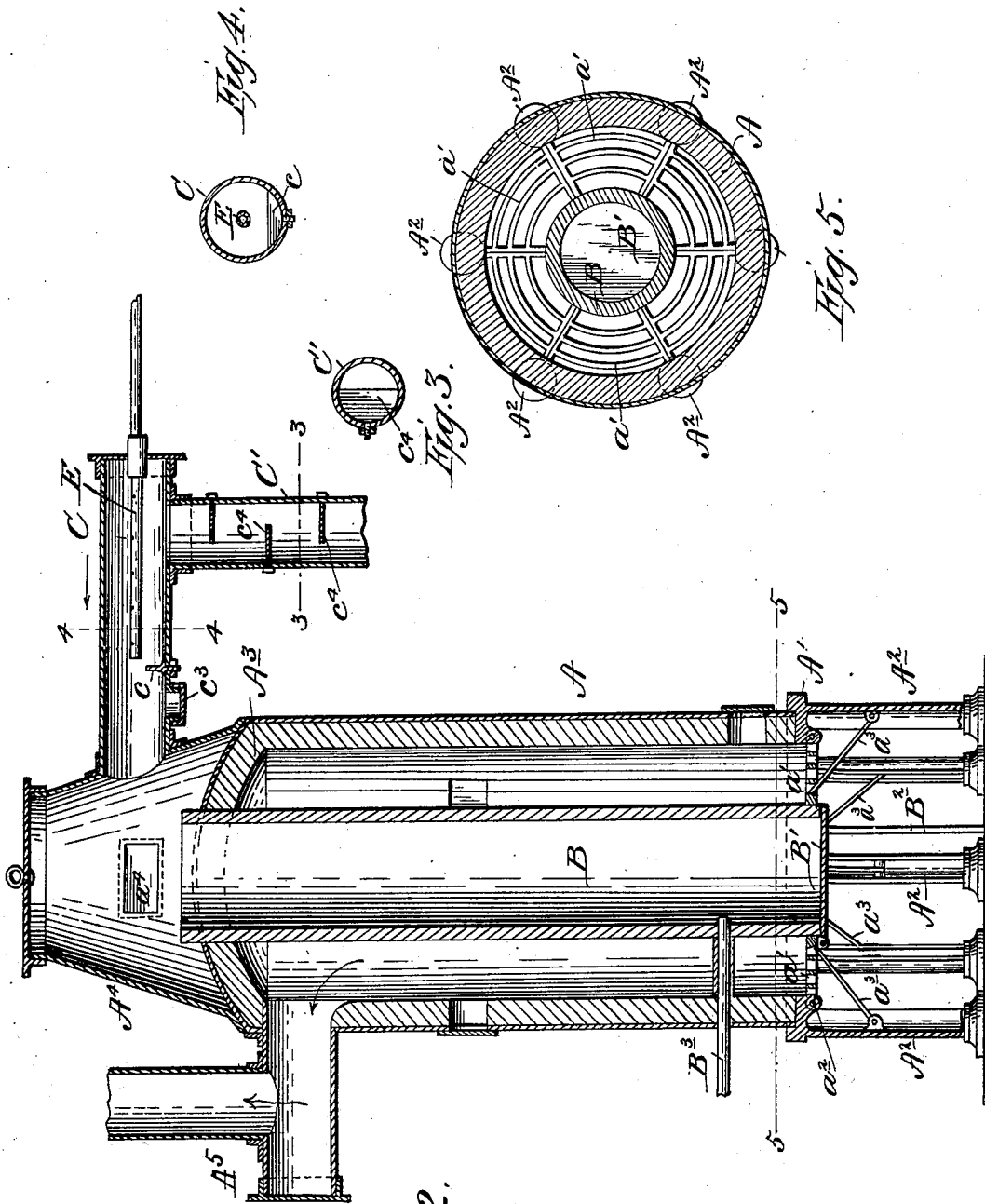

Witnesses
Francis L. Curand.
A. Y. Bell

Fig. 2.

Inventor
Samuel S. Bridges
by Geo. H. Evans
Attorney

UNITED STATES PATENT OFFICE.

SAMUEL G. BRIDGES, OF KANSAS CITY, MISSOURI.

APPARATUS FOR TREATING ZINC ORES.

SPECIFICATION forming part of Letters Patent No. 666,597, dated January 22, 1901.

Application filed November 5, 1900. Serial No. 35,591. (No model.)

To all whom it may concern:

Be it known that I, SAMUEL G. BRIDGES, a citizen of the United States, residing at Kansas City, county of Jackson, and State of Missouri, have invented certain new and useful Improvements in Apparatus for Treating Zinc Ore, of which the following is a specification.

My invention relates to that class of apparatus in which the ore is subjected to a temperature which will convert the metal therein to fumes or to a gaseous state, which fumes are condensed, thereby converting the zinc fumes into oxid of zinc in the form of an impalpable powder, the sulfur and other impurities being removed in the form of a solution.

The objects of the invention are to provide a simple and efficient apparatus for carrying on the treatment of zinc ore continuously and in which the fumes from the ore being heated will be kept separate from the products of combustion issuing from the furnace, to trap any unvaporized zinc in advance of the pump, and to thoroughly agitate the fumes in a condensing-tank in which the sulfur is removed and from which tank the oxid of zinc passes to one of a series of settling-tanks, in which it is allowed to settle. These objects I accomplish by the mechanism shown in the accompanying drawings, in which—

Figure 1 is a side elevation of my apparatus, partly in section. Fig. 2 is a central vertical section through the furnace. Fig. 3 is a detail section on line 3 3 of Fig. 2. Fig. 4 is a similar view on line 4 4 of Fig. 2. Fig. 5 is a horizontal section on line 5 5 of Fig. 2.

A designates the upright furnace, of any suitable construction and lined, as usual, with fire-brick. This furnace A rests upon a circular base A', supported by a circularly-arranged series of pillars A². Within the furnace is placed the central vertical fire-clay retort B, supported at its lower end on the center of the base A', so that an annular fire and combustion space will be formed between the furnace and retort. At the lower end of this annular space the base is provided with a series of downwardly-swinging grate-sections a', pivoted at a². The inner free ends of these grate-sections are held up by the upper ends of the rods a³, hinged at their lower ends to the pillars, as clearly shown in Fig. 2. The bottom of the retort B is closed by a down-

wardly-swinging door B', held closed by a removable rod B². The upper end of the retort B projects through the arched dome A³ of the furnace and discharges into the chamber formed by the top A⁴. This top has a removable cover and an opening a⁴, through which ore may be introduced into the retort.

A⁵ is the smoke-outlet from the furnace, and the furnace is provided, as usual, with fuel and like doors. Any suitable fuel may be used for heating the retort.

B³ is a pipe discharging steam or air into the retort just above the body of ore being treated to supply oxygen to cause the oxidation of the rising fumes. This pipe may be entered from any desired point; but I have shown it passing through the furnace, and so it will have to be covered sufficiently to protect it from heat.

C is a horizontal condensing or cooling pipe leading from the top A⁴, and from the outer end of this pipe depends the vertical pipe C', connected between the ends to the inlet side of a pump D by a horizontal branch c'. Below this branch c' the pipe C' forms a trap C², having any suitable form of valved outlet c² at its lower end.

E is a spray-pipe within the condensing-pipe C to throw a series of small jets of water therein to commingle with, cool, and condense the fumes in their passage through said pipe C.

In order that the water may not run into the retort B, I provide a dam c, secured in place by a suitable bolt and nut. (See Fig. 4.) Between the dam c and inner end of pipe C, I provide in the bottom thereof an outlet having a removable cap c³, so that any solid matter lodging in front of the dam may be readily removed.

The pipe C' is provided with a series of alternately-arranged baffle-plates c⁴, which are secured in place by bolts and nuts, as shown in Figs. 2 and 3.

F is a deflector set in the pipe C', just over the entrance to the branch c', so that any gritty matter or unvaporized zinc sucked in by the pump will strike this deflector and fall down into the trap C² instead of being carried to the pump, to the great injury thereof. After the apparatus has been running long enough the trap C² will gradually fill,

and its contents must be removed from time to time through valve C², and after drying the deposit it may be returned to the retort for further treatment.

5 From the outlet side of the pump extends the inverted-U-shaped pipe G, the member *g* of which extends down to the bottom of the closed condensing-tank H and is provided with a series of baffle-plates *g'*, like those in
10 pipe C'. The lower portion of the pipe-section *g* is provided with numerous small perforations *g*², and over this perforated portion of the pipe depends a concentric hood *g*³, closed at its top, but open at its lower end,
15 as shown in Fig. 1. From the upper end of this tank H leads a pipe *h*, which extends down to near the bottom of an open settling-tank H', which in turn is similarly connected with a second settling-tank H² by the pipe *h*².
20 As many of these tanks may be provided as may be found necessary, and the several tanks will be provided with draw-off cocks or outlets *h*³.

The operation is as follows: The fire hav-
25 ing been started, the retort having been supplied with ore, the water turned on in pipe E, and the pump started, the heat converts the zinc in the ore to fumes, which are oxidized by the air or steam, and the sulfur is
30 likewise converted into gaseous form. The zinc and sulfur fumes are drawn by the pump through the pipe C, where they are acted upon by the water-spray and separated and condensed to a certain extent, and from the
35 pipe C these fumes are further separated and condensed in passing back and forth across the baffle-plates *c*⁴. In passing the deflector F all gritty matter, such as unvaporized zinc, will be deflected and drop down into the trap
40 C². The liquid and fumes will now enter the pump D and be forced through pipe G, where they will be further acted upon by the baffle-plates *g'* and finally ejected violently through apertures *g*² into the hood *g*³. In this tank
45 the water is caused to take up the sulfur, and dilute sulfurous acid will be the result. The overflow from this tank passes into the first settling-tank H', and in this tank the oxid of zinc precipitates in the form of a fine flour
50 or impalpable powder perfectly free from all gritty matter, sulfur, &c. Any remaining oxid of zinc will be deposited in the second tank H². The sulfurous liquid in these tanks will be drawn off from time to time and the
55 sulfuric acid recovered therefrom in any well-known manner of recovering such by-product, and after the liquid is so drawn off the oxid of zinc will then be removed and treated by drying, &c. Owing to the violent agitation of the contents of closed tank H nothing
60 will be deposited there until after the pump ceases to operate, after which the contents of tank H may be removed in like manner to the contents of the settling-tanks H'.

If desired, more than one retort may be placed in a furnace.

What I claim is—

1. A fume-arrester comprising a pump, a pipe for conveying fumes to the pump and provided with a water-supply and baffle-plates, a trap in advance of the pump-inlet to prevent the admission of solid matter to the pump, a condensing-tank and a vertically-disposed pipe leading from the pump into the condensing-tank; substantially as described.

2. An apparatus for treating zinc ore, comprising a suitable furnace, a retort, a pipe leading from the retort, a pump connected with said pipe to draw the fumes from the retort, a water-supply in said pipe, a condensing-tank, a pipe leading from the pump to the condensing-tank and provided near the bottom of the tank with a series of perforations, a concentric hood surrounding the perforated portion of the pipe and open at its lower end, and a settling-tank connected with the upper portion of the condensing-tank.

3. In a zinc-ore apparatus, the combination with the retort and its furnace, of a horizontal pipe leading from the retort and provided with a spraying-pipe, a dam to prevent the water running into the retort, a removable cap between the dam and retort to permit removal of deposit, a vertical pipe leading down from the outer end of horizontal pipe and provided with alternately-arranged baffle-plates, a pump to which the lower end of said pipe is connected, a condensing-chamber into which the pump discharges, and a settling-tank connected to the condensing-tank.

4. In an apparatus for treating zinc, the closed condensing-tank having a supply-pipe leading down thereinto and provided with lateral perforations, and a concentric hood on the perforated portion of the pipe and open at its lower end, substantially as and for the purpose set forth.

5. An apparatus for treating zinc ore, comprising a furnace, a retort therein, a chamber above the furnace into which the upper end of the retort opens, a pump on a lower level than said chamber, a pipe leading from said chamber and having a lateral branch connecting it with the pump, baffle-plates in said pipe, a water-spray in the upper part of said pipe, a trap at the lower end of the pipe, a deflector F over said lateral branch to cause any solid matter to fall into the trap, a closed condensing-tank connected with outlet side of pump, and a settling-tank receiving overflow from said condensing-tank.

In testimony whereof I affix my signature in presence of two witnesses.

SAMUEL G. BRIDGES.

Witnesses:

GEO. H. EVANS,
A. P. GREELEY.