

(No Model.)

2 Sheets—Sheet 1.

G. A. GEER.
APPARATUS FOR VENTILATING CARS.

No. 526,702.

Patented Oct. 2, 1894.

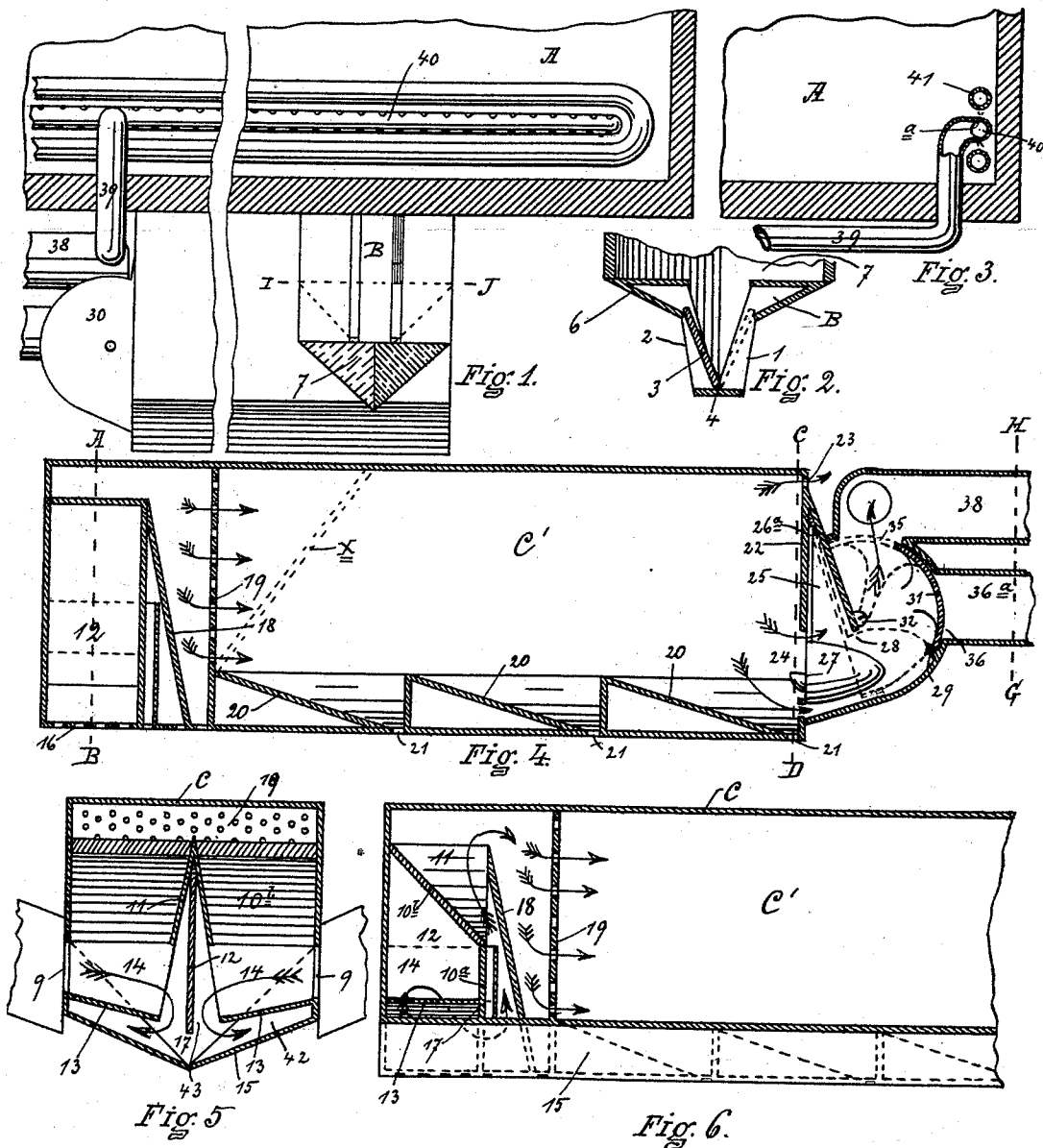

WITNESSES.
Rich. A. George.
J. B. Smith

INVENTOR.
GILES A. GEER
BY *Rusby, Robinson & Lutz*
ATTORNEY'S.

(No Model.)

2 Sheets—Sheet 2.

G. A. GEER.
APPARATUS FOR VENTILATING CARS.

No. 526,702.

Patented Oct. 2, 1894.

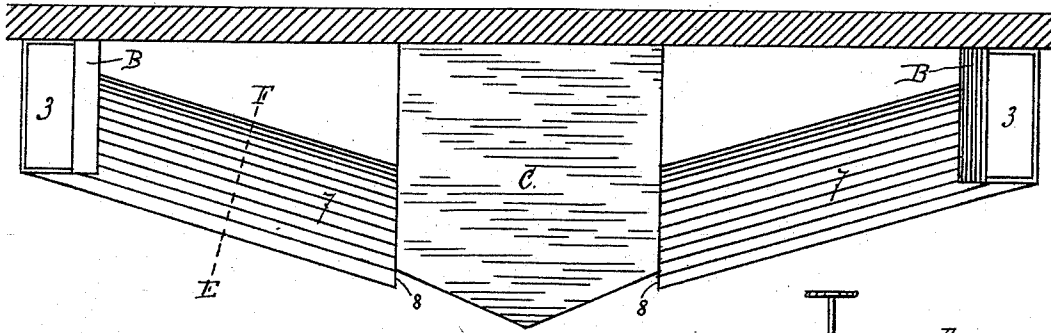

Fig. 7.

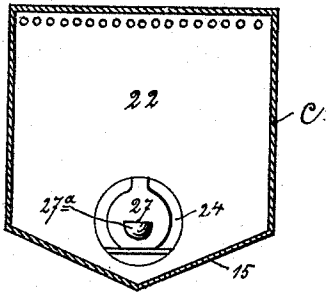

Fig. 8.

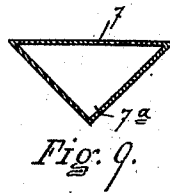

Fig. 9.

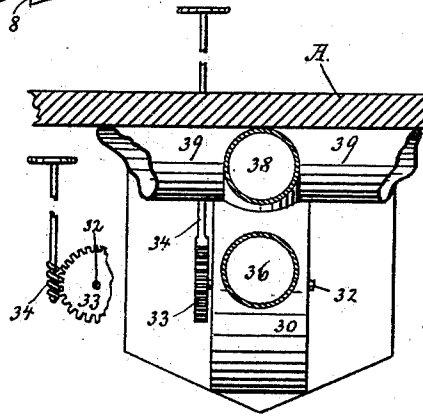
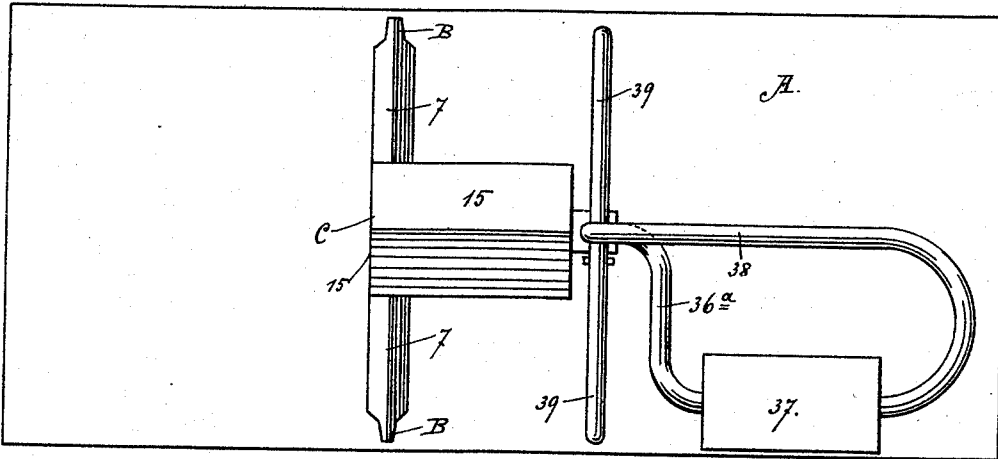

Fig. 10.

Fig. 11.



WITNESSES.
Rich. A. George
D. B. Smith

INVENTOR.
GILES A. GEER.
BY *Rusley, Robinson & Love*
ATTORNEY'S.

UNITED STATES PATENT OFFICE.

GILES A. GEER, OF UTICA, NEW YORK.

APPARATUS FOR VENTILATING CARS.

SPECIFICATION forming part of Letters Patent No. 526,702, dated October 2, 1894.

Application filed December 1, 1893. Serial No. 492,516. (No model.)

To all whom it may concern:

Be it known that I, GILES A. GEER, of Utica, in the county of Oneida and State of New York, have invented certain new and useful Improvements in Apparatus for Ventilating Cars; and I do hereby declare that the following is a full, clear, and exact description of the invention, which will enable others skilled in the art to which it appertains to make and use the same, reference being had to the accompanying drawings, and to the letters and figures of reference marked thereon, which form part of this specification.

My invention relates to an improvement in apparatus for ventilating cars.

The object is to supply fresh air for ventilating purposes to a car in motion, and at the same time free the air thus supplied from dust and impurities, and at the same time regulating automatically the supply of air and thoroughly distribute it in the interior of the car. By an additional appliance, I may also wash or cool the air as desired.

In the drawings, Figure 1 shows a side view of a portion of the apparatus in connection with a section of car, showing the distributing portion of the apparatus located therein; the figure being broken to shorten or reduce its size. Fig. 2 shows a cross section of the receiver taken on line I—J of Fig. 1, on a larger scale. Fig. 3 shows in connection with a section of car the air passage or conductor for conveying the air into the interior of the car and distributing it. Fig. 4 shows a longitudinal, vertical, central section of the settling or clearing chamber together with the portion of the apparatus attached to either end thereof. Fig. 5 shows a cross section of the settling chamber taken on line A—B of Fig. 4. Fig. 6 shows a portion of the settling chamber as it would appear with one of the sides removed. Fig. 7 shows an end view of the apparatus as located under a car, showing the two receivers at either side of the car, the settling chamber suspended under the middle of the car and the air tubes leading from the receiver to the settling chamber. Fig. 8 shows a section on line C—D of Fig. 4. Fig. 9 shows a section of the air tube or conductor taken on line E—F of Fig. 7. Fig. 10 shows an end view of the settling chamber with the apparatus mounted thereon, being

the opposite end from that seen in Fig. 7, with two of the conductor pipes or air passages taken on a section at G—H of Fig. 4. Fig. 11 shows a plan view from the under side of the apparatus as arranged on the under side of the car.

Referring more particularly to the reference letters and numerals in a more specific description of the device, I provide on the under side of a car A suspended therefrom adjacent to the sides, receivers B, B. These receivers are of the form shown in cross section in Fig. 2, having openings 1 and 2 to the atmosphere with a swing door or valve 3 located between the openings 1 and 2 and pivoted at 4 on a vertical pivot at its outer side. The swinging edge of the door or valve 3 plays between the edges of the walls 5 and 6 of the receiver.

To the side of the receiver B toward the central line of the car, is attached one end of the V-shaped air passage or conductor 7. The air tubes or passages 7 extend from the receiver B on a downwardly sloping incline to the end of the settling chamber C. The lower V-shaped corner 7^a of the tube 7 does not register exactly with the side of the chamber C, but projects slightly below leaving an opening at 8 for the escape of cinders and dirt. The tubes or passages 7 from the receivers B at either side of the car communicate at the settling chamber with the openings 9—9 in the opposite sides thereof. These openings are partitioned off from the end of the chamber C by the partition consisting of the two parts 10^a and 10^b; the lower portion extending up from the bottom to about the central horizontal line of the chamber and the portion 10^b from the upper edge of this nearly to the top of the chamber on an incline. On the middle portion of the partition 10^b is provided a gable 11. In this gable is suspended from a horizontal pivot a swinging valve 12; the lower end of which plays in the opening 43 between the inner ends of the bottoms 13—13 of the air passages 14 extending from the openings 9 in the side of the chamber. The chamber C is provided, as shown at 15, with a V-shaped bottom, and in the portion of the chamber between the partition 10^a and the end of the chamber is provided a series of small openings 16 for the escape of dirt and cinders. At the lower edge of the inclined

partition 10^b on the side toward the body of the chamber is provided a V-shaped chute 17 which concentrates what dirt and cinders may be deposited on and shake off from the partition 10^b at one of the openings 16 where they will escape at the same time removing them from the current of air. Next to the partition consisting of the parts 10^a and 10^b is provided a partial partition 18 which extends from the bottom nearly to the top of the chamber and engages at its upper edge against the end of the gable 11. Next following this partial partition is a perforated partition 19 entirely crossing and closing the chamber. The V-shaped bottom 15 of the chamber is continued through under the body portion C' thereof and in the body portion are provided a series of inclined bottoms 20—20, each of which terminates at a small opening 21 in the V-shaped bottom and allows what dirt and cinders that may have entered the device thus far to escape and be discharged.

In the end of the head 22 of the settling chamber along the upper edge thereof is provided a few holes or perforations 23 to allow the smoke and gases that have arisen to the top chamber in the slow passage of the air through the same, to escape to the open atmosphere and not pass with the air into the car. From the body C' of the chamber the desirable portion of the air passes through an opening at 24 into a valve chamber 25 in which is suspended from a pivot at 26 a conoidal shaped valve 27 with its base end opposed to the opening 24 which is larger than the base end, and its apex end adapted to play through an opening 28 in the opposite wall of the valve chamber. On the base end of the valve I provide a pocket 27^a for weighting the valve. The swinging movement of this valve is limited by the apex end coming in contact with a stop 29.

Attached on the inclined wall of the valve chamber is a semi-circular chamber 30 which contains the cut-off valve 31; the valve being mounted on a shaft 32 which extends to the outside and is provided with a worm gear 33 in which engages the worm 34 by which the valve is operated. The shaft of the worm 34 may extend to the interior of the car, as shown, or to any other desired point from which it is desirable to operate this valve.

Communicating with the valve chamber 30 are two exit openings 35 and 36. To the exit opening 36 is attached a pipe 36^a which may extend to an ice box or cooling chamber 37 and the return pipe from this box is shown at 38. From the exit opening 35 also extend passage-ways 39 to opposite sides of the car where they enter the car and are attached to the perforated pipes 40 extending along the sides of the car for distributing the air throughout the length of the car. The distributing pipe 40 is preferably located between two radiating steam pipes 41—41 and the perforations shown at *a* are in a position to direct the blast of air on to the radiating pipe.

As a car equipped with the apparatus as herein shown is moved forward, the atmospheric pressure swings the valve 3 so as to close one or the other of the openings 1 or 2 in the receiver and the air enters through the other, being deflected by the door or valve and passes thence into the passage-way or tube 7 to the box or chamber C. If an equal amount of air is received from the two receivers on both sides the valve 12 will remain suspended in its normal and vertical position and the air will circulate, as shown by the arrows in Fig. 5 passing from the triangular conductor 7 through the opening 9 into the passage-way 42 below the partitions 13 and thence as indicated by the arrows in Fig. 6 up behind the inclined partition 18 and over the top of the same and through the perforated partition 19 as also indicated by the arrows.

In case an unequal amount of air is received from the two receivers B, B on opposite sides of the car, the valve 12 will be swung by the atmospheric pressure so as to accommodate the greater amount of air received from one source than the other, and in some cases may even shut off one of the openings 14 entirely. By this arrangement the air entering one receiver is not able to escape through the other receiver in case of an unequal pressure, but must pass through the apparatus in the manner intended by its construction.

After passing the partition 19, the air, by reason of the greater area, circulates slowly through the body C' and any dust or cinders that may have been carried thus far will settle onto the inclines 20 and by the jar from the car be worked out through the openings 21 in the bottom; also during the slow passage of the air through the body C' of the settling chamber, the smoke and gases carried by the air are allowed to rise and escape through the openings 23. The desirable portion of the air passes on through the opening 24 and the opening 28 and depending on the point to which the valve 31 is adjusted, either through the box 37 with its connecting pipes into the interior of the car or directly through the escape opening 35 and connecting pipes into the interior of the car, or partially through each of these passage-ways. In the car the air is distributed from the perforated pipe 40 as before described.

I may modify the construction of the device by placing the perforated partition 19 on an incline, as shown at *x*, and other variations and modifications in and from the construction herein described may be made without departing from the equivalents of my construction.

What I claim as new, and desire to secure by Letters Patent, is—

1. In a ventilating apparatus for cars, an air receiver secured on the car with inlet openings on either side to the atmosphere, a swinging door or valve located between the openings and mounted at its outer edge on pivots

in a vertical line to be swung by atmospheric pressure to either side to close one of the inlet openings and deflect the current of air, and an air passage connecting the receiver with the interior of the car, combined substantially as set forth.

2. In a ventilating apparatus for cars, an air receiver suspended from the lower edge of the car having openings toward the ends of the car on either side of the receiver to the atmosphere, a swinging door or valve pivoted to swing about a vertical pivotal line at its edge between the openings and adapted to be swung by atmospheric pressure to either side to close one or the other of the openings and deflect the current of air, and an air passage connecting the receiver with the interior of the car, combined substantially as set forth.

3. In an apparatus for ventilating cars, two automatic adjusting receivers for catching the air, located on opposite sides of the car and communicating by suitable passageways with a common chamber between the receivers, and a suspended automatic valve operating in the common delivery opening from the two receivers and adapted to be operated by atmospheric pressure for the purpose of adjusting the common delivery opening to adapt it to receive an unequal amount of air from the two receivers or to close the passageway from one entirely, substantially as set forth.

4. In an apparatus for ventilating cars, receivers, a settling chamber having inclined bottoms centering at escape openings in the bottom of the chamber, an inlet opening at one end of the chamber, a passageway between the receivers, and inlet opening, a vertical perforated partition between the inlet opening and portion of chamber having the inclined bottoms, a discharge opening at the

opposite end of the chamber and a passageway connecting the discharge openings with the interior of the car, combined, substantially as set forth.

5. In an apparatus for ventilating cars, an air passage, a valve chamber having vertical and inclined walls with coinciding openings in each, an automatic conoidal-shaped valve suspended in the valve chamber between the openings with its base toward the current of air and adapted to automatically regulate the amount of air passing through the apparatus, substantially as set forth.

6. In an apparatus for ventilating cars, the combination of receivers B having openings on either side to the atmosphere, a swinging valve operated by atmospheric pressure to close one or the other of the openings forming a pocket for receiving the air, a conductor into which the receiver delivers the air, a settling chamber having a suspended swinging valve in the common air passage or opening from receivers, a deflecting partition in the settling chamber extending from the bottom nearly to the top, a perforated distributing and commingling partition, an enlarged interior opening or chamber having inclined bottoms centering at common escape openings, a discharge opening from the body portion of the chamber, an automatic valve controlling the discharge opening, and conductors for conveying the air into the interior of the car and distributing the same, substantially as set forth.

In witness whereof I have affixed my signature in presence of two witnesses.

GILES A. GEER.

Witnesses:

GEORGE A. GAYMONDS,
ARTHUR W. SAVAGE.