



(86) **Date de dépôt PCT/PCT Filing Date:** 2016/08/18
 (87) **Date publication PCT/PCT Publication Date:** 2017/02/23
 (45) **Date de délivrance/Issue Date:** 2023/08/29
 (85) **Entrée phase nationale/National Entry:** 2018/02/08
 (86) **N° demande PCT/PCT Application No.:** US 2016/047622
 (87) **N° publication PCT/PCT Publication No.:** 2017/031354
 (30) **Priorité/Priority:** 2015/08/18 (US62/206,637)

(51) **Cl.Int./Int.Cl. C23C 16/04** (2006.01),
A61J 1/05 (2006.01), **A61L 31/08** (2006.01),
C23C 16/30 (2006.01), **C23C 16/40** (2006.01),
C23C 16/515 (2006.01)
 (72) **Inventeurs/Inventors:**
 WILLS, MATTHEW, US;
 TAHA, AHMAD, US;
 WEIKART, CHRISTOPHER, US
 (73) **Propriétaire/Owner:**
 SIO2 MEDICAL PRODUCTS, INC., US
 (74) **Agent:** RIDOUT & MAYBEE LLP

(54) **Titre : CONDITIONNEMENT PHARMACEUTIQUE ET AUTRE PRESENTANT UN FAIBLE TAUX DE TRANSMISSION D'OXYGENE**

(54) **Title: PHARMACEUTICAL AND OTHER PACKAGING WITH LOW OXYGEN TRANSMISSION RATE**

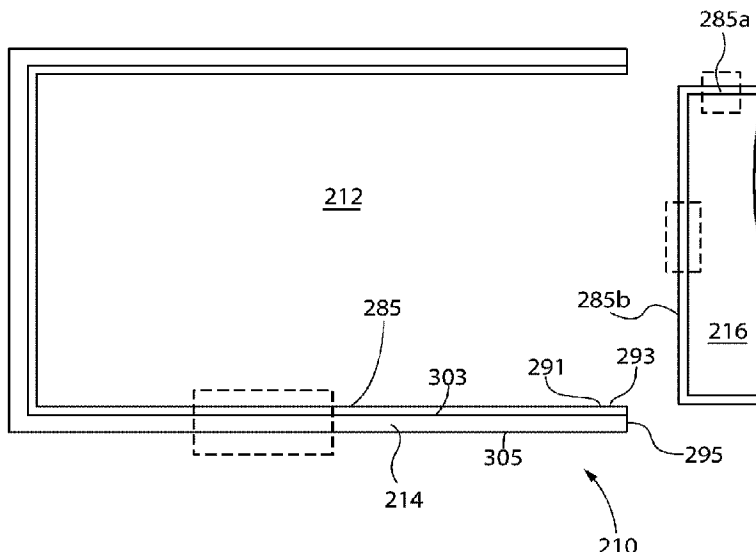

(57) **Abrégé/Abstract:**

Processing an evacuated blood sample collection tube or other vessel by plasma enhanced chemical vapor deposition to apply a tie coating or layer (289), a barrier coating or layer (288), and optionally one or more additional coatings or layers. The tie coating or layer of SiOxCy is applied under partial vacuum and, while maintaining the partial vacuum unbroken in the lumen, the barrier coating or layer is applied. Then optionally, while maintaining the partial vacuum unbroken in the lumen, a pH protective coating or layer of SiOxCy can be applied. As a result of this processing, a coated vessel is produced having a lower gas permeation rate constant into the lumen than a corresponding vessel made by the same process except breaking the partial vacuum in the lumen between applying the tie coating or layer and applying the barrier coating or layer. Retention features are also described for keeping the vessels stoppered during exposure to reduced ambient pressure.

WO 2017/031354 A3 

(88) Date of publication of the international search report:
4 May 2017

PHARMACEUTICAL AND OTHER PACKAGING
WITH LOW OXYGEN TRANSMISSION RATE

RELATED APPLICATIONS

[0001]

Pat. No. 7,985,188

The specification and drawings of U.S.
filed June 26, 2015,

describes apparatus, vessels, precursors, coatings or layers and methods (in particular coating methods and test methods for examining the coatings or layers) which can generally be used in performing the present invention, in some cases as modified herein. They also describe SiOxCy tie coatings or layers and pH protective coatings or layers and SiOx barrier coatings or layers to which reference is made herein.

FIELD OF THE INVENTION

[0002] The present invention relates to the technical field of barrier coated surfaces, for example interior surfaces of pharmaceutical packages or other vessels for storing or other contact with fluids. Examples of suitable fluids include foods, nutritional supplements, drugs, inhalation anaesthetics, diagnostic test materials, or biologically active compounds or body fluids, for example blood. The present invention also relates to a blood collection tube or other vessel having a gas barrier coating and optionally a pH protective coating to protect the gas barrier coating.

[0003] The present disclosure also relates to improved methods for processing pharmaceutical packages or other vessels, for example multiple identical pharmaceutical packages or other vessels used for pharmaceutical preparation storage and delivery, venipuncture and other medical sample collection (for example evacuated blood sample collection tubes), and other purposes.

-2-

[0004] The present disclosure also relates to the resulting packages pharmaceutical packages or other vessels. Such pharmaceutical packages or other vessels are used in large numbers, and must be relatively economical to manufacture and yet highly reliable in storage and use.

BACKGROUND OF THE INVENTION

[0005] One important consideration in manufacturing pharmaceutical packages or other vessels for storing or other contact with fluids, for example vials, pre-filled syringes, or sample collection tubes, is that the contents of the pharmaceutical package or other vessel desirably will have a substantial shelf life. During this shelf life, it is important to isolate any material contained in the pharmaceutical package or other vessel from the vessel wall containing it, or from barrier layers or other functional layers applied to the pharmaceutical package or other vessel wall to avoid extracting material from the pharmaceutical package or other vessel wall, barrier layer, or other functional layers into the prefilled contents or vice versa.

[0006] Some companies have turned to plastic pharmaceutical packages or other vessels, which provide greater dimensional tolerance and less breakage than glass, but the use of plastic for primary pharmaceutical packaging remains limited due to its relatively high gas (oxygen) permeation rate: Plastic allows small molecule gases to permeate into (or out of) the article. The permeation rate constants of plastics to gases are significantly greater than that of glass and, in many cases (as with oxygen-sensitive drugs such as epinephrine), plastics have been unacceptable for that reason.

[0007] The problem of the relatively high permeation rate constant of thermoplastic vessels has been addressed by adding a barrier coating or layer to the vessel wall. One such barrier layer is a very thin coating of SiO_x, as defined below, applied by plasma enhanced chemical vapor deposition to the internal surface of the wall defining the lumen. But, current SiO_x barrier layers deposited on a package by PECVD are etched off by aqueous contents of the vessels having pH-values greater than 4, particularly at higher pH values. This reduces the useful shelf life of the vessel as its barrier efficacy is reduced.

-3-

[0008] Consider more particularly evacuated blood sample collection tubes, which are sold with the lumen evacuated. The vacuum is used to draw blood from a patient into the tube, and the level of vacuum determines its draw volume capacity -- how much blood the tube can draw before the pressure is equalized and flow stops. Evacuated blood sample collection tubes made of polymeric thermoplastic material are permeable to atmospheric gases such as air or its component gases such as oxygen and nitrogen, which reduce the vacuum level within the tube as time passes. If the vacuum is reduced too much, insufficient blood will be drawn to meet the specifications of the sample tube. A common specification is that, throughout its shelf life, the evacuated blood sample collection tube must maintain a draw volume capacity of at least 90% of the draw volume capacity of a newly evacuated vessel of the same kind. A barrier coating or layer is useful to prevent atmospheric gases from entering the thermoplastic polymeric vessel during its shelf life and thus provide a tube that meets this specification over a desirably long shelf life.

[0009] Many such sample tubes also contain a reagent which is introduced at the time of manufacture and remains in the lumen until blood or another sample is introduced and contacted with the reagent. The reagent may be in contact with the vessel wall and any coatings on the wall for as long as the shelf life of the sample collection tube. Many such aqueous reagents, for example the buffered sodium citrate reagent commonly used to prevent coagulation of blood introduced into the blood sample collection tube, may damage the SiO_x barrier coating or layer if directly in contact with the barrier coating or layer. Consequently, it has been found useful to apply over the barrier protective coating or layer a pH protective coating or layer to prevent direct contact between the barrier coating or layer and the reagent or other contents in the lumen.

BRIEF SUMMARY OF THE INVENTION

[0010] An aspect of the invention is a method of processing a vessel to apply a tie coating or layer (289), a barrier coating or layer, and optionally one or more additional coatings or layers.

-4-

[0011] To carry out the process, a vessel is provided including a wall consisting essentially of thermoplastic polymeric material defining a lumen. The wall has an inside surface (303) facing the lumen and an outside surface.

[0012] During the process, a partial vacuum is drawn in the lumen. While maintaining the partial vacuum unbroken in the lumen, a tie coating or layer of SiO_xC_y is applied by a tie PECVD coating process. The tie PECVD coating process is carried out by applying sufficient power to generate plasma within the lumen while feeding a gas suitable for forming the coating. The gas feed includes a linear siloxane precursor, optionally oxygen, and optionally an inert gas diluent. The values of x and y are as determined by X-ray photoelectron spectroscopy (XPS). Then, while maintaining the partial vacuum unbroken in the lumen, the plasma is extinguished. A tie coating or layer of SiO_xC_y , for which x is from about 0.5 to about 2.4 and y is from about 0.6 to about 3, is produced on the inside surface as a result.

[0013] Later during the process, while maintaining the partial vacuum unbroken in the lumen, a barrier coating or layer is applied by a barrier PECVD coating process. The barrier PECVD coating process is carried out by applying sufficient power to generate plasma within the lumen while feeding a gas. The gas feed includes a linear siloxane precursor and oxygen. A barrier coating or layer of SiO_x , wherein x is from 1.5 to 2.9 as determined by XPS is produced between the tie coating or layer and the lumen as a result.

[0014] Then optionally, while maintaining the partial vacuum unbroken in the lumen, the plasma is extinguished.

[0015] Later, as a further option, a pH protective coating or layer of SiO_xC_y can be applied. In this formula as well, x is from about 0.5 to about 2.4 and y is from about 0.6 to about 3, each as determined by XPS. The pH protective coating or layer is optionally applied between the barrier coating or layer and the lumen, by a pH protective PECVD coating process. This process includes applying sufficient power to generate plasma within the lumen while feeding a gas including a linear siloxane precursor, optionally oxygen, and optionally an inert gas diluent.

-5-

[0016] As a result of this processing, a coated vessel is produced having a lower gas permeation rate constant into the lumen than a corresponding vessel made by the same process except breaking the partial vacuum in the lumen between applying the tie coating or layer and applying the barrier coating or layer.

[0017] Another aspect of the invention is an evacuated blood collection tube made according to any of the methods described above.

[0018] Another aspect of the invention is a coated vessel comprising a wall, a tie coating or layer, a barrier coating or layer, and optionally a pH protective coating or layer, made by the process defined below.

[0019] The wall consists essentially of thermoplastic polymeric material defining a lumen. The wall has an interior surface facing the lumen and an exterior surface.

[0020] The tie coating or layer consists essentially of SiO_xC_y , wherein x is from about 0.5 to about 2.4 and y is from about 0.6 to about 3, each as determined by X-ray photoelectron spectroscopy (XPS), on the interior surface.

[0021] The barrier coating or layer consists essentially of SiO_x , wherein x is from 1.5 to 2.9 as determined by XPS, between the tie coating or layer and the lumen.

[0022] The optional pH protective coating or layer consists essentially of SiO_xC_y , wherein x is from about 0.5 to about 2.4 and y is from about 0.6 to about 3, each as determined by XPS, between the barrier coating or layer and the lumen.

[0023] The coated vessel is formed by a process comprising several steps. A vessel is provided comprising the wall. A partial vacuum is drawn in the lumen. While maintaining the partial vacuum unbroken in the lumen, the tie coating or layer of SiO_xC_y is applied by a tie PECVD process comprising applying sufficient power (alternatively the same concept is referred to in this specification as "energy") to generate plasma within the lumen while feeding a gas comprising a linear siloxane precursor, optionally oxygen, and optionally an inert gas diluent.

[0024] Then, while maintaining the partial vacuum unbroken in the lumen, the plasma is extinguished. After that, while still maintaining the partial vacuum unbroken in the lumen, the barrier coating or layer is applied by a barrier PECVD

-6-

process comprising applying sufficient power to generate plasma within the lumen while feeding a gas comprising a linear siloxane precursor and oxygen.

[0025] If the optional pH protective coating or layer is applied, this may optionally be done according to the following process.

[0026] Optionally after applying the barrier coating or layer, while maintaining the partial vacuum unbroken in the lumen, the plasma is extinguished.

[0027] Then optionally, while maintaining the partial vacuum unbroken in the lumen, the pH protective coating or layer of SiOxCy is applied by a pH protective PECVD process. The pH protective PECVD process comprises applying sufficient power to generate plasma within the lumen while feeding a gas comprising a linear siloxane precursor, optionally oxygen, and optionally an inert gas diluent.

[0028] The result of the process is a coated vessel.

[0029] Surprisingly, the coated vessel made by this process has a lower gas permeation rate constant into the lumen than a corresponding vessel made by the same process except breaking the partial vacuum in the lumen between applying the tie coating or layer and applying the barrier coating or layer. Alternatively, the coated vessel made by this process including the optional steps has a lower gas permeation rate constant into the lumen than a corresponding vessel made by the same process except breaking the partial vacuum in the lumen between applying the tie coating or layer and the barrier coating or layer, and also breaking the partial vacuum in the lumen between applying the barrier coating or layer and the pH protective coating or layer.

[0030] Another aspect of the invention is an evacuated blood collection tube comprising a coated vessel as defined above and a closure sealing the lumen. The lumen has a vacuum level sufficient to draw blood from a patient's vein into the lumen.

[0031] Still another aspect of the invention is an evacuated blood collection tube which can be a thermoplastic vessel wall having a top defining an opening, an inside surface defining a lumen, an outside surface, and a stopper contact area on the

-7-

inside surface adjacent to the top. The stopper contact area is tapered inward from 0 to 1.3 degrees.

[0032] A still further aspect of the invention is an evacuated blood collection tube including: a thermoplastic vessel wall having a top, an inside surface defining a lumen, and an outside surface. A retention lip projects radially inward from the inside surface. The inside surface includes a stopper contact area adjacent to and below the retention lip.

[0033] Further aspects, features, and embodiments of the invention are provided in the following description and claims.

BRIEF DESCRIPTION OF SEVERAL VIEWS OF THE DRAWINGS

[0034] FIG. 1 is a schematic sectional view of a vessel according to any embodiment of the invention.

[0035] FIG. 2 is an enlarged detail view of a portion of the vessel wall and coatings of FIG. 1.

[0036] FIG. 3 is a plot of oxygen permeability rate constant (OPRC) vs. storage time with pH 9 buffered phosphate solution for 6 mL vials made according to the present invention ("all combined") with a trilayer coating, compared to similar vials made with a vacuum break between layers.

[0037] FIG. 4 is a top plan view of a more detailed embodiment of a pharmaceutical package or vessel of FIGS. 1 and 2, suitable for use as an evacuated blood collection tube.

[0038] FIG. 5 is a longitudinal section of the embodiment of FIG. 4, taken along the section line 5—5 of FIG. 4.

[0039] FIG. 6 is an enlarged fragmentary detail view of FIG. 5.

[0040] FIG. 7 is a Fourier Transform Infrared Spectrophotometer (FTIR) plot for a pH protective layer made according to the present description.

[0041] The following reference characters are used in the drawing figures:

-8-

210	Pharmaceutical package or vessel
212	Lumen
214	Wall
216	Closure
285	Vessel coating or layer set
286	pH protective coating or layer
288	Barrier coating or layer
289	Tie coating or layer
291	Stopper contact area (of 210)
293	Retention lip
295	Top (of 210)
297	Lower end (of 293)
299	Lower ramp
301	Upper ramp
303	Inside surface (of 214)
305	Outside surface (of 214)
307	Lower end (of 301)

DEFINITIONS

[0042] In the context of the present invention, the following definitions and abbreviations are used:

[0043] RF is radio frequency.

[0044] The term "at least" in the context of the present invention means "equal or more" than the integer following the term. The word "comprising" does not exclude

-9-

other elements or steps, and the indefinite article "a" or "an" does not exclude a plurality unless indicated otherwise. Whenever a parameter range is indicated, it is intended to disclose the parameter values given as limits of the range and all values of the parameter falling within said range.

[0045] "First" and "second" or similar references to anything refer to the minimum number of such things that are present, but do not necessarily represent the order or total number of such things or require additional such things beyond the stated number. For example, a "first" deposit in the context of this specification can be either the only deposit or any one of plural deposits, without limitation. In other words, recitation of a "first" deposit allows but does not require an embodiment that also has a second or further deposit.

[0046] For purposes of the present invention, an "organosilicon precursor" is a compound having at least one of the linkages:

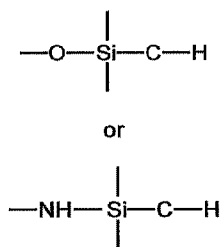

which is a tetravalent silicon atom connected to an oxygen or nitrogen atom and an organic carbon atom (an organic carbon atom being a carbon atom bonded to at least one hydrogen atom). A volatile organosilicon precursor, defined as such a precursor that can be supplied as a vapor in a PECVD apparatus, is an optional organosilicon precursor. Optionally, the organosilicon precursor is selected from the group consisting of a linear siloxane, a monocyclic siloxane, a polycyclic siloxane, a polysilsesquioxane, an alkyl trimethoxysilane, a linear silazane, a monocyclic

-10-

silazane, a polycyclic silazane, a polysilsesquiazane, and a combination of any two or more of these precursors.

[0047] The feed amounts of PECVD precursors, gaseous reactant or process gases, and carrier gas are sometimes expressed in "standard volumes" in the specification and claims. The standard volume of a charge or other fixed amount of gas is the volume the fixed amount of the gas would occupy at a standard temperature and pressure (without regard to the actual temperature and pressure of delivery). Standard volumes can be measured using different units of volume, and still be within the scope of the present disclosure and claims. For example, the same fixed amount of gas could be expressed as the number of standard cubic centimeters, the number of standard cubic meters, or the number of standard cubic feet. Standard volumes can also be defined using different standard temperatures and pressures, and still be within the scope of the present disclosure and claims. For example, the standard temperature might be 0°C and the standard pressure might be 760 Torr (as is conventional), or the standard temperature might be 20°C and the standard pressure might be 1 Torr. But whatever standard is used in a given case, when comparing relative amounts of two or more different gases without specifying particular parameters, the same units of volume, standard temperature, and standard pressure are to be used relative to each gas, unless otherwise indicated.

[0048] The corresponding feed rates of PECVD precursors, gaseous reactant or process gases, and carrier gas are expressed in standard volumes per unit of time in the specification. For example, in the working examples the flow rates are expressed as standard cubic centimeters per minute, abbreviated as sccm. As with the other parameters, other units of time can be used, such as seconds or hours, but consistent parameters are to be used when comparing the flow rates of two or more gases, unless otherwise indicated.

[0049] A "vessel" in the context of the present invention can be any type of vessel with a wall defining an inner or interior surface. Though the invention is not necessarily limited to sample collection tubes, pharmaceutical packages, or other

-11-

vessels of a particular volume, pharmaceutical packages or other vessels are contemplated in which the lumen has a void volume of from 0.5 to 250 mL, optionally from 1 to 20 mL, optionally from 0.5 to 12 mL, optionally from 1 to 3 mL. The substrate surface can be part or all of the inner or interior surface of a vessel having at least one opening and an inner or interior surface. Some examples of pharmaceutical and other packages and vessels include, but are not limited to, a sample collection tube, an evacuated blood sample collection tube (which commonly is provided in a small size containing about 6 mL or a large size containing about 12 mL), a sample storage tube, a vial, a plastic-coated vial, a syringe, a plastic coated syringe, a blister pack, an ampoule, a plastic coated ampoule, a cartridge, a bottle, a plastic coated bottle, a centrifuge tube, a chromatography vial, tubing, a pouch, a pump, a sprayer, a stopper, a needle, a plunger, a cap, a stent, a catheter or an implant.

[0050] Additionally, a vessel according to the present invention can be a sample tube, for example for collecting or storing biological fluids like blood or urine, a syringe part, for example a syringe barrel, for storing or delivering a biologically active compound or composition, for example a medicament or pharmaceutical composition, a vial for storing biological materials or biologically active compounds or compositions, a pipe or tubing, for example a catheter for transporting biological materials or biologically active compounds or compositions, or a cuvette for holding fluids, for example for holding biological materials or biologically active compounds or compositions.

[0051] A vessel can be of any shape. A vessel having a substantially cylindrical wall adjacent to at least one of its open ends is preferred. Generally, the interior wall of the vessel is cylindrically shaped, like, for example in a sample tube or a syringe barrel. Sample tubes and syringes or their parts (for example syringe barrels) are contemplated.

[0052] The values of w, x, y, and z are applicable to the empirical composition $\text{Si}_w\text{O}_x\text{C}_y\text{H}_z$ throughout this specification, and the same values of x and y are applicable to the empirical composition SiO_xC_y throughout this specification. The

-12-

values of w, x, y, and z should be understood as ratios or an empirical formula (for example for a coating or layer), rather than as a limit on the number or type of atoms in a molecule. For example, octamethylcyclotetrasiloxane, which has the molecular composition $\text{Si}_4\text{O}_4\text{C}_8\text{H}_{24}$, can be described by the following empirical formula, arrived at by dividing each of w, x, y, and z in the molecular formula by 4, the largest common factor: $\text{Si}_1\text{O}_1\text{C}_2\text{H}_6$. The values of w, x, y, and z are also not limited to integers. For example, (acyclic) octamethyltrisiloxane, molecular composition $\text{Si}_3\text{O}_2\text{C}_8\text{H}_{24}$, is reducible to $\text{Si}_1\text{O}_0.67\text{C}_2.67\text{H}_8$.

[0053] The atomic ratio of $\text{Si}_w\text{O}_x\text{C}_y\text{H}_z$ can only be partially determined by XPS, since H atoms are not detectable by XPS. Hydrogen atoms are, however, detectable using a different analysis, for example Rutherford Backscattering or Rutherford Forward Scattering. A particular coating or layer may thus in one aspect be expressed by the formula $\text{Si}_w\text{O}_x\text{C}_y\text{H}_z$, for example where w is 1, x is from about 0.5 to about 2.4, y is from about 0.6 to about 3, and z is from about 2 to about 9. The same particular coating or layer can alternatively be characterized by XPS only, without accounting for hydrogen, and thus expressed by the formula $\text{Si}_x\text{O}_y\text{C}_z$, in which x is from about 0.5 to about 2.4 and y is from about 0.6 to about 3. $\text{Si}_x\text{O}_y\text{C}_z$ has no subscript following Si, which has the same meaning as a subscript w of 1 in the formula $\text{Si}_w\text{O}_x\text{C}_y\text{H}_z$. In this specification, XPS is generally used without accounting for hydrogen, and the atomic ratio is expressed as $\text{Si}_x\text{O}_y\text{C}_z$. Typically, such coating or layer would hence contain 36% to 41% carbon normalized to 100% carbon plus oxygen plus silicon.

[0054] The term "syringe" is broadly defined to include cartridges, injection "pens," and other types of barrels or reservoirs adapted to be assembled with one or more other components to provide a functional syringe. "Syringe" is also broadly defined to include related articles such as auto-injectors, which provide a mechanism for dispensing the contents.

[0055] Processing a vessel "while maintaining the partial vacuum unbroken in the lumen" of a vessel means continuing processing of the vessel without introducing

-13-

sufficient gas into the lumen to bring its pressure to substantially, exactly, or more than ambient atmospheric pressure.

[0056] The gas permeation rate constant into the lumen (abbreviated as GPRC) is a characteristic of the vessel wall, and means the instantaneous rate of permeation of the atmosphere or some other specified gas (in μmol or micromoles per day) from outside a closed container into the lumen of the container through its wall, for a wall surface area of 1 cm^2 and a gas partial pressure difference of 1 atmosphere (standard atmosphere pressure) across the wall. The gas permeation rate constant can be measured in units of $\mu\text{mol} / (\text{day} \times \text{cm}^2 \times \text{atm.})$ This term does not include gas bypassing the wall, as by leaking between the wall and a closure or permeating through the closure.

[0057] “The coated vessel having lower gas permeation rate constant into the lumen than a corresponding vessel made by the same process except breaking the partial vacuum in the lumen between applying the adhesion coating or layer and applying the barrier coating or layer” is largely self-explanatory. In the context of this language, “breaking the partial vacuum in the lumen” means introducing sufficient gas into the lumen to bring its pressure to substantially, exactly, or more than ambient atmospheric pressure.

[0058] The shelf life of a vessel is defined as the period of time after the date of manufacture when the vessel can be used and function properly. For example, the shelf life of an evacuated blood collection tube is the period of time after the date of evacuation when the evacuated blood collection tube maintains a draw volume capacity of at least 90% of the draw volume capacity of a newly evacuated vessel of the same kind.

[0059] The change in draw volume capacity can be measured directly by a physical measurement of draw volume versus time, or it can be estimated by applying a multiplier to the oxygen permeation rate constant (OPRC) to account for the nitrogen permeation rate constant of the vessel in question, then determining the combined oxygen plus nitrogen permeation rate constant. The remaining gases in ambient air are usually too dilute to be determined for this calculation.

-14-

[0060] As a rule of thumb, the ratio of nitrogen and oxygen permeation rate constants is fairly constant for a wide range of polymers (D.W. van Krevelen, Properties of Polymers, 1990, Table 18.6). The permeation rate constant of oxygen is about 3.8 times the permeation rate constant of nitrogen in the same polymer.

TABLE 18.6
Relative values of permeability parameters (Rules of thumb)

Gas	<i>P</i>	<i>D</i>	<i>S</i>	<i>E_P</i>	<i>E_D</i>
N ₂ (=1)	1	1	1	1	1
CO	1.2	1.1	1.1	1	1
CH ₄	3.4	0.7	4.9	(1)	(1)
O ₂	3.8	1.7	2.2	0.86	0.90
He	15	60	0.25	0.62	0.45
H ₂	22.5	30	0.75	0.70	0.65
CO ₂	24	1	24	0.75	1.03
H ₂ O	(550)	5	—	0.75	0.75

DETAILED DESCRIPTION OF THE INVENTION

[0061] The present invention will now be described more fully, with reference to the accompanying drawings, in which several embodiments are shown. This invention can, however, be embodied in many different forms and should not be construed as limited to the embodiments set forth here. Rather, these embodiments are examples of the invention, which has the full scope indicated by the language of the claims. Like numbers refer to like or corresponding elements throughout. The following disclosure relates to all embodiments unless specifically limited to a certain embodiment.

Vessels and Coating Sets

[0062] The contemplated coated vessel, including the vessel illustrated in FIGS. 1, 2, and 4-6, comprises a wall 214 and a vessel coating or layer set 285, comprising a tie coating or layer 289, a barrier coating or layer 288, and optionally a pH protective coating or layer 286 on at least a portion of the wall 214 facing the lumen 212, made by the process defined below.

-15-

[0063] The vessel may be more specifically a sample collection tube such as an evacuated blood collection tube, a vial, a syringe, a blister pack, an ampoule, a cartridge, a bottle, a pouch, a pump, a sprayer, a stopper, a needle, a plunger, a cap, a stent, a catheter or an implant, or any other type of container or conduit for a fluid. Figs. 1 and 2 show a vessel having at least a single opening, and should be understood to include a vessel having two or more openings, such as a syringe, or a vessel having no openings, such as a pouch, blister pack, or ampoule. The wall can be made of any thermoplastic polymeric material, which optionally comprises a polyester, polyethylene terephthalate (PET), polyethylene naphthalate (PEN); a polyolefin, cyclic olefin polymer (COP), cyclic olefin copolymer (COC), polypropylene (PP), or a polycarbonate, preferably COP. If water permeability is less important than oxygen permeability, a PET wall is expressly contemplated, as PET has more water permeability but roughly an order of magnitude less oxygen permeability than COP.

[0064] An embodiment of the vessel coating or layer set 285 is at least one tie coating or layer 289, at least one barrier coating or layer 288, and at least one pH protective coating or layer 286 (which is optional), illustrated in Figs. 1, 2. This embodiment of the vessel coating or layer set with all three coatings is sometimes known as a "trilayer coating" in which the barrier coating or layer 288 of SiOx is protected against contents having a pH otherwise high enough to remove it by being sandwiched between the pH protective coating or layer 286 and the tie coating or layer 289, each an organic layer of SiOxCy as defined in this specification. Specific examples of this trilayer coating is provided in this specification.

[0065] In addition to its average atomic proportions expressed by the formula SiOxCy, the pH protective coating or layer 286 can be characterized by its FTIR spectrum, a representative example of which is shown in FIG. 7. The peak assignments for the pH protective coating or layer 286 are:

[0066] Chemical Bonds Wavenumber (cm-1)

- Si-O-Si (asymmetric stretch) 1080-1200

-16-

- Si-O-Si (symmetric stretch) 1020-1080
- C-H 2960
- Si-H 2100
- Si-CH₃ 1273
- Si-(CH₃)_x 800-830

Commonly in the FTIR spectrum for the pH protective coating or layer 286, the Si-O-Si symmetric stretch and asymmetric stretch peaks appear to merge, forming a simple peak, while in the spectra for lubricity coatings (referred to for example in U.S. Pat. No. 7,985,188) the Si-O-Si symmetric stretch and asymmetric stretch peaks form a compound peak having a shoulder on the lower wave number side (the right side in FIG. 7), the shoulder being indicative of asymmetric stretch.

[0067] The contemplated thicknesses of the respective layers in nm (preferred ranges in parentheses) are given in the Trilayer Thickness Table 1.

Adhesion	Barrier	Protection
5-100 (5-20)	20-200 (20-30)	50-500 (100-200)

[0068] The trilayer coating set 285 optionally includes as a first layer an adhesion or tie coating or layer 289 that improves adhesion of the barrier coating or layer to the COP substrate. The adhesion or tie coating or layer 289 is also believed to relieve stress on the barrier coating or layer 288, making the barrier layer less subject to damage from thermal expansion or contraction or mechanical shock. The adhesion or tie coating or layer 289 is also believed to decouple defects between the barrier coating or layer 288 and the COP substrate. This is believed to occur because any pinholes or other defects that may be formed when the adhesion or tie coating or layer 289 is applied tend not to be continued when the barrier coating or layer 288 is applied, so the pinholes or other defects in one coating do not line up with defects in the other. The adhesion or tie coating or layer 289 has some efficacy

-17-

as a barrier layer, so even a defect providing a leakage path extending through the barrier coating or layer 289 is blocked by the adhesion or tie coating or layer 289.

[0069] The trilayer coating set 285 includes as a second layer a barrier coating or layer 288 that provides a barrier to oxygen that has permeated the COP barrel wall. The barrier coating or layer 288 also is a barrier to extraction of the composition of the barrel wall 214 by the contents of the lumen 214.

[0070] The trilayer coating set 285 optionally includes as a third layer a pH protective coating or layer 286 that provides protection of the underlying barrier coating or layer 288 against contents of the vessel having a pH from 4 to 8 or more, including where a surfactant is present. For a prefilled vessel that is in contact with the contents of the vessel from the time it is manufactured to the time it is used, the pH protective coating or layer 286 prevents or inhibits attack of the barrier coating or layer 288 sufficiently to maintain an effective oxygen barrier over the intended shelf life of the prefilled vessel.

[0071] The rate of erosion, dissolution, extraction, or leaching (different names for related concepts) of the pH protective coating or layer 286, if directly contacted by a fluid having a pH of from 5 to 9, is less than the rate of erosion of the barrier coating or layer 288, if directly contacted by the fluid having a pH of from 5 to 9. The pH protective coating or layer 286 is effective to isolate a fluid 218 having a pH between 5 and 9 from the barrier coating or layer 288, at least for sufficient time to allow the barrier coating to act as a barrier during the shelf life of the pharmaceutical package or other vessel 210.

[0072] Oxygen permeation rate constant (OPRC) is deemed appropriate to verify integrity of barrier coatings.

Tie Coating or Layer

[0073] The tie coating or layer consists essentially of SiO_xC_y , wherein x is from about 0.5 to about 2.4 and y is from about 0.6 to about 3, each as determined by X-ray photoelectron spectroscopy (XPS), on the interior surface.

-18-

[0074] The tie coating or layer 289 has at least two functions. One function of the tie coating or layer 289 is to improve adhesion of a barrier coating or layer 288 to a substrate, in particular a thermoplastic substrate, although a tie layer can be used to improve adhesion to a glass substrate or to another coating or layer. For example, a tie coating or layer, also referred to as an adhesion layer or coating, can be applied to the substrate and the barrier layer can be applied to the adhesion layer to improve adhesion of the barrier layer or coating to the substrate.

[0075] Another function of the tie coating or layer 289 has been discovered: a tie coating or layer 289 applied under a barrier coating or layer 288 can improve the function of a pH protective coating or layer 286 applied over the barrier coating or layer 288.

[0076] The tie coating or layer 289 can be composed of, comprise, or consist essentially of SiO_xC_y , in which x is between 0.5 and 2.4 and y is between 0.6 and 3. The atomic ratios of Si, O, and C in the tie coating or layer 289 are, as several options:

Si 100 : O 50–150 : C 90-200 (i.e. $w = 1$, $x = 0.5$ to 1.5 , $y = 0.9$ to 2);

Si 100 : O 70–130 : C 90-200 (i.e. $w = 1$, $x = 0.7$ to 1.3 , $y = 0.9$ to 2)

Si 100 : O 80–120 : C 90-150 (i.e. $w = 1$, $x = 0.8$ to 1.2 , $y = 0.9$ to 1.5)

Si 100 : O 90-120 : C 90-140 (i.e. $w = 1$, $x = 0.9$ to 1.2 , $y = 0.9$ to 1.4), or

Si 100 : O 92-107 : C 116-133 (i.e. $w = 1$, $x = 0.92$ to 1.07 , $y = 1.16$ to 1.33)

The atomic ratio can be determined by XPS.

[0077] Optionally, the tie coating or layer can be similar or identical in composition with the pH protective coating or layer 286 described elsewhere in this specification, although this is not a requirement.

[0078] The tie coating or layer 289 is contemplated in any embodiment generally to be from 5 nm to 100 nm thick, preferably from 5 to 20 nm thick, particularly if applied by chemical vapor deposition. These thicknesses are not critical.

-19-

Commonly but not necessarily, the tie coating or layer 289 will be relatively thin, since its function is to change the surface properties of the substrate.

Barrier Layer

[0079] The barrier coating or layer consists essentially of SiO_x, wherein x is from 1.5 to 2.9 as determined by XPS, between the tie coating or layer and the lumen.

[0080] A barrier coating or layer 288 optionally can be deposited by plasma enhanced chemical vapor deposition (PECVD) or other chemical vapor deposition processes on the vessel of a pharmaceutical package, in particular a thermoplastic package, to prevent oxygen, carbon dioxide, or other gases from entering the vessel and/or to prevent leaching of the pharmaceutical material into or through the package wall.

[0081] The barrier coating or layer for any embodiment defined in this specification (unless otherwise specified in a particular instance) is a coating or layer, optionally applied by PECVD as indicated in U.S. Pat. No. 7,985,188. The barrier layer optionally is characterized as an "SiO_x" coating, and contains silicon, oxygen, and optionally other elements, in which x, the ratio of oxygen to silicon atoms, is from about 1.5 to about 2.9, or 1.5 to about 2.6, or about 2. These alternative definitions of x apply to any use of the term SiO_x in this specification. The barrier coating or layer is applied, for example to the interior of a pharmaceutical package or other vessel, for example a sample collection tube, a syringe barrel, a vial, or another type of vessel.

[0082] The barrier coating 288 comprises or consists essentially of SiO_x, wherein x is from 1.5 to 2.9, from 2 to 1000 nm thick, the barrier coating 288 of SiO_x having an interior surface 220 facing the lumen 212 and an outer surface 222 facing the wall 214 article surface 254, the barrier coating 288 being effective to reduce the ingress of atmospheric gas into the lumen 212 compared to an uncoated vessel 250. One suitable barrier composition is one where x is 2.3, for example. For example, the barrier coating or layer such as 288 of any embodiment can be applied at a thickness of at least 2 nm, or at least 4 nm, or at least 7 nm, or at least 10 nm, or at

-20-

least 20 nm, or at least 30 nm, or at least 40 nm, or at least 50 nm, or at least 100 nm, or at least 150 nm, or at least 200 nm, or at least 300 nm, or at least 400 nm, or at least 500 nm, or at least 600 nm, or at least 700 nm, or at least 800 nm, or at least 900 nm. The barrier coating or layer can be up to 1000 nm, or at most 900 nm, or at most 800 nm, or at most 700 nm, or at most 600 nm, or at most 500 nm, or at most 400 nm, or at most 300 nm, or at most 200 nm, or at most 100 nm, or at most 90 nm, or at most 80 nm, or at most 70 nm, or at most 60 nm, or at most 50 nm, or at most 40 nm, or at most 30 nm, or at most 20 nm, or at most 10 nm, or at most 5 nm thick. Ranges of 20-200 nm, optionally 20-30 nm, are contemplated. Specific thickness ranges composed of any one of the minimum thicknesses expressed above, plus any equal or greater one of the maximum thicknesses expressed above, are expressly contemplated.

[0083] The thickness of the SiO_x or other barrier coating or layer can be measured, for example, by transmission electron microscopy (TEM), and its composition can be measured by X-ray photoelectron spectroscopy (XPS). The primer coating or layer described herein can be applied to a variety of pharmaceutical packages or other vessels made from plastic or glass, for example to plastic tubes, vials, and syringes.

[0084] A barrier coating or layer 286 of SiO_x, in which x is between 1.5 and 2.9, is applied by plasma enhanced chemical vapor deposition (PECVD) directly or indirectly to the thermoplastic wall 214 (for example a tie coating or layer 289 can be interposed between them) so that in the filled pharmaceutical package or other vessel 210 the barrier coating or layer 286 is located between the inner or interior surface 220 of the thermoplastic wall 214 and the fluid 218.

[0085] The barrier coating or layer 286 of SiO_x is supported by the thermoplastic wall 214. The barrier coating or layer 286 as described elsewhere in this specification, or in U.S. Patent No. 7,985,188, can be used in any embodiment.

[0086] Certain barrier coatings or layers 286 such as SiO_x as defined here have been found to have the characteristic of being subject to being measurably diminished in barrier improvement factor in less than six months as a result of attack

-21-

by certain relatively high pH contents of the coated vessel as described elsewhere in this specification, particularly where the barrier coating or layer directly contacts the contents. This issue can be addressed using a pH protective coating or layer as discussed in this specification.

pH Protective Coating or Layer

[0087] The optional pH protective coating or layer consists essentially of SiO_xC_y , wherein x is from about 0.5 to about 2.4 and y is from about 0.6 to about 3, each as determined by XPS, between the barrier coating or layer and the lumen.

[0088] The inventors have found that barrier layers or coatings of SiO_x are eroded or dissolved by some fluids, for example aqueous compositions having a pH above about 4, alternatively above about 5. Since coatings applied by chemical vapor deposition can be very thin – tens to hundreds of nanometers thick – even a relatively slow rate of erosion can remove or reduce the effectiveness of the barrier layer in less time than the desired shelf life of a product package. This is particularly a problem for fluid pharmaceutical compositions, since many of them have a pH of roughly 7, or more broadly in the range of 5 to 9, similar to the pH of blood and other human or animal fluids. The higher the pH of the pharmaceutical preparation, the more quickly it erodes or dissolves the SiO_x coating. Optionally, this problem can be addressed by protecting the barrier coating or layer 288, or other pH sensitive material, with a pH protective coating or layer 286.

[0089] Optionally, the pH protective coating or layer 286 can be composed of, comprise, or consist essentially of $\text{Si}_w\text{O}_x\text{C}_y\text{H}_z$ (or its equivalent SiO_xC_y) or $\text{Si}_w\text{N}_x\text{C}_y\text{H}_z$ or its equivalent $\text{Si}(\text{NH})_x\text{C}_y$. The atomic ratio of Si : O : C or Si : N : C can be determined by XPS (X-ray photoelectron spectroscopy). The pH protective coating or layer may thus in one aspect have the formula SiO_xC_y , where x is from about 0.5 to about 2.4 and y is from about 0.6 to about 3. The same pH protective coating or layer may thus in another aspect have the formula $\text{SiO}_x\text{C}_y\text{H}_z$, where x is from about 0.5 to about 2.4 and y is from about 0.6 to about 3, and z is from about 2 to about 9.

-22-

[0090] Typically, expressed as the formula $\text{Si}_w\text{O}_x\text{C}_y$, where $w=1$, the atomic ratios of Si, O, and C are, as several options:

- Si 100 : O 50–150 : C 90-200 (i.e. $w = 1$, $x = 0.5$ to 1.5 , $y = 0.9$ to 2);
- Si 100 : O 70–130 : C 90-200 (i.e. $w = 1$, $x = 0.7$ to 1.3 , $y = 0.9$ to 2)
- Si 100 : O 80–120 : C 90-150 (i.e. $w = 1$, $x = 0.8$ to 1.2 , $y = 0.9$ to 1.5)
- Si 100 : O 90-120 : C 90-140 (i.e. $w = 1$, $x = 0.9$ to 1.2 , $y = 0.9$ to 1.4)
- Si 100 : O 92-107 : C 116-133 (i.e. $w = 1$, $x = 0.92$ to 1.07 , $y = 1.16$ to 1.33), or
- Si 100 : O 80–130 : C 90-150.

[0091] Alternatively, the pH protective coating or layer can have atomic concentrations normalized to 100% carbon, oxygen, and silicon, as determined by X-ray photoelectron spectroscopy (XPS) of less than 50% carbon and more than 25% silicon. Alternatively, the atomic concentrations are from 25 to 45% carbon, 25 to 65% silicon, and 10 to 35% oxygen. Alternatively, the atomic concentrations are from 30 to 40% carbon, 32 to 52% silicon, and 20 to 27% oxygen. Alternatively, the atomic concentrations are from 33 to 37% carbon, 37 to 47% silicon, and 22 to 26% oxygen.

[0092] The thickness of the pH protective coating or layer can be, for example, from 10 nm to 1000 nm; alternatively from 10 nm to 1000 nm; alternatively from 10 nm to 900 nm; alternatively from 10 nm to 800 nm; alternatively from 10 nm to 700 nm; alternatively from 10 nm to 600 nm; alternatively from 10 nm to 500 nm; alternatively from 10 nm to 400 nm; alternatively from 10 nm to 300 nm; alternatively from 10 nm to 200 nm; alternatively from 10 nm to 100 nm; alternatively from 10 nm to 50 nm; alternatively from 20 nm to 1000 nm; alternatively from 50 nm to 1000 nm; alternatively from 10 nm to 1000 nm; alternatively from 50 nm to 800 nm; alternatively from 100 nm to 700 nm; alternatively from 300 to 600 nm.

-23-

[0093] Optionally, the atomic concentration of carbon in the protective layer, normalized to 100% of carbon, oxygen, and silicon, as determined by X-ray photoelectron spectroscopy (XPS), can be greater than the atomic concentration of carbon in the atomic formula for the organosilicon precursor. For example, embodiments are contemplated in which the atomic concentration of carbon increases by from 1 to 80 atomic percent, alternatively from 10 to 70 atomic percent, alternatively from 20 to 60 atomic percent, alternatively from 30 to 50 atomic percent, alternatively from 35 to 45 atomic percent, alternatively from 37 to 41 atomic percent.

[0094] Optionally, the atomic ratio of carbon to oxygen in the pH protective coating or layer can be increased in comparison to the organosilicon precursor, and/or the atomic ratio of oxygen to silicon can be decreased in comparison to the organosilicon precursor.

[0095] Optionally, the pH protective coating or layer can have an atomic concentration of silicon, normalized to 100% of carbon, oxygen, and silicon, as determined by X-ray photoelectron spectroscopy (XPS), less than the atomic concentration of silicon in the atomic formula for the feed gas. For example, embodiments are contemplated in which the atomic concentration of silicon decreases by from 1 to 80 atomic percent, alternatively by from 10 to 70 atomic percent, alternatively by from 20 to 60 atomic percent, alternatively by from 30 to 55 atomic percent, alternatively by from 40 to 50 atomic percent, alternatively by from 42 to 46 atomic percent.

[0096] As another option, a pH protective coating or layer is contemplated in any embodiment that can be characterized by a sum formula wherein the atomic ratio C : O can be increased and/or the atomic ratio Si : O can be decreased in comparison to the sum formula of the organosilicon precursor.

[0097] The pH protective coating or layer 286 commonly is located between the barrier coating or layer 288 and the fluid 218 in the finished article. The pH protective coating or layer 286 is supported by the thermoplastic wall 214.

-24-

[0098] The pH protective coating or layer 286 optionally is effective to keep the barrier coating or layer 288 at least substantially undissolved as a result of attack by the fluid 218 for a period of at least six months.

[0099] The pH protective coating or layer can have a density between 1.25 and 1.65 g/cm³, alternatively between 1.35 and 1.55 g/cm³, alternatively between 1.4 and 1.5 g/cm³, alternatively between 1.4 and 1.5 g/cm³, alternatively between 1.44 and 1.48 g/cm³, as determined by X-ray reflectivity (XRR). Optionally, the organosilicon compound can be octamethylcyclotetrasiloxane and the pH protective coating or layer can have a density which can be higher than the density of a pH protective coating or layer made from HMDSO as the organosilicon compound under the same PECVD reaction conditions.

[00100] The pH protective coating or layer optionally can prevent or reduce the precipitation of a compound or component of a composition, in particular can prevent or reduce insulin precipitation or blood clotting, in comparison to the uncoated surface and/or to a barrier coated surface using HMDSO as precursor.

[00101] The pH protective coating or layer optionally can have an RMS surface roughness value (measured by AFM) of from about 5 to about 9, optionally from about 6 to about 8, optionally from about 6.4 to about 7.8. The Ra surface roughness value of the pH protective coating or layer, measured by AFM, can be from about 4 to about 6, optionally from about 4.6 to about 5.8. The Rmax surface roughness value of the pH protective coating or layer, measured by AFM, can be from about 70 to about 160, optionally from about 84 to about 142, optionally from about 90 to about 130.

[00102] The interior surface of the pH protective optionally can have a contact angle (with distilled water) of from 90° to 110°, optionally from 80° to 120°, optionally from 70° to 130°, as measured by Goniometer Angle measurement of a water droplet on the pH protective surface, per ASTM D7334 - 08 "Standard Practice for Surface Wettability of Coatings, Substrates and Pigments by Advancing Contact Angle Measurement."

-25-

[00103] The passivation layer or pH protective coating or layer 286 ("passivation layer" and "pH protective coating or layer" are two different names for the same thing) optionally shows an O-Parameter measured with attenuated total reflection (ATR) Fourier-transform infrared spectrometry (FTIR) of less than 0.4, measured as:

$$\text{O-Parameter} = \frac{\text{Intensity at } 1253 \text{ cm}^{-1}}{\text{Maximum intensity in the range } 1000 \text{ to } 1100 \text{ cm}^{-1}}$$

[00104] The O-Parameter is defined in U.S. Patent No. 8,067,070, which claims an O-parameter value of most broadly from 0.4 to 0.9. It can be measured from physical analysis of an FTIR amplitude versus wave number plot to find the numerator and denominator of the above expression. The O-Parameter can also be measured from digital wave number versus absorbance data.

[00105] U.S. Patent No. 8,067,070 asserts that the claimed O-parameter range provides a superior pH protective coating or layer. Surprisingly, it has been found by the present inventors that O-parameters outside the ranges claimed in U.S. Patent No. 8,067,070 provide better results than are obtained in U.S. Patent No. 8,067,070.

[00106] Alternatively in the embodiment of FIGS. 1-2, the O-parameter has a value of from 0.1 to 0.39, or from 0.15 to 0.37, or from 0.17 to 0.35.

[00107] Even another aspect of the invention is a composite material as just described, exemplified in FIGS. 1-5, wherein the passivation layer shows an N-Parameter measured with attenuated total reflection (ATR) Fourier-transform infrared spectrometry (FTIR) of less than 0.7, measured as:

$$\text{N-Parameter} = \frac{\text{Intensity at } 840 \text{ cm}^{-1}}{\text{Intensity at } 799 \text{ cm}^{-1}}$$

[00108] The N-Parameter is also described in U.S. Patent No. 8,067,070, and is measured analogously to the O-Parameter except that intensities at two specific wave numbers are used – neither of these wave numbers is a range. U.S. Patent No. 8,067,070 claims a passivation layer with an N-Parameter of 0.7 to 1.6. Again,

-26-

the present inventors have made better coatings employing a pH protective coating or layer 286 having an N-Parameter lower than 0.7, as described above. Alternatively, the N-parameter has a value of at least 0.3, or from 0.4 to 0.6, or at least 0.53.

[00109] The rate of erosion, dissolution, extraction, or leaching (different names for related concepts) of the pH protective coating or layer 286, if directly contacted by the fluid 218, is less than the rate of erosion, dissolution, extraction, or leaching of the barrier coating or layer 288, if directly contacted by the fluid 218.

[00110] The thickness of the pH protective coating or layer is contemplated in any embodiment to be from 50-500 nm, with a preferred range of 100-200 nm.

[00111] The pH protective coating or layer 286 is effective to isolate the fluid 218 from the barrier coating or layer 288, at least for sufficient time to allow the barrier coating to act as a barrier during the shelf life of the pharmaceutical package or other vessel 210.

[00112] The inventors have further found that certain pH protective coatings or layers of SiOxCy or Si(NH)xCy formed from siloxane precursors, which pH protective coatings or layers have a substantial organic component, do not erode quickly when exposed to fluids, and in fact erode or dissolve more slowly when the fluids have higher pHs within the range of 5 to 9. For example, at pH 8, the dissolution rate of a pH protective coating or layer is quite slow. These pH protective coatings or layers of SiOxCy or Si(NH)xCy can therefore be used to cover a barrier layer of SiOx, retaining the benefits of the barrier layer by protecting it from the fluid in the pharmaceutical package. The protective layer is applied over at least a portion of the SiOx layer to protect the SiOx layer from contents stored in a vessel, where the contents otherwise would be in contact with the SiOx layer.

[00113] Effective SiOxCy or Si(NH)xCy pH protective coatings or layers can be deposited, for example, from linear siloxane or linear silazane precursors, for example hexamethyldisiloxane (HMDSO) or tetramethyldisiloxane (TMDSO), or from cyclic siloxane precursors, for example octamethylenecyclotetrasiloxane (OMCTS).

-27-

[00114] Optionally an FTIR absorbance spectrum of the pH protective coating or layer 286 of any embodiment has a ratio greater than 0.75 between the maximum amplitude of the Si-O-Si symmetrical stretch peak normally located between about 1000 and 1040 cm⁻¹, and the maximum amplitude of the Si-O-Si asymmetric stretch peak normally located between about 1060 and about 1100 cm⁻¹. Alternatively in any embodiment, this ratio can be at least 0.8, or at least 0.9, or at least 1.0, or at least 1.1, or at least 1.2. Alternatively in any embodiment, this ratio can be at most 1.7, or at most 1.6, or at most 1.5, or at most 1.4, or at most 1.3. Any minimum ratio stated here can be combined with any maximum ratio stated here, as an alternative embodiment of the invention of FIGS. 1-5.

[00115] Optionally, for the pH protective coating or layer 286 in any embodiment, the silicon dissolution rate by a 50 mM potassium phosphate buffer diluted in water for injection, adjusted to pH 8 with concentrated nitric acid, and containing 0.2 wt. % polysorbate-80 surfactant, (measured in the absence of the medicament, to avoid changing the dissolution reagent), at 40°C, is less than 170 ppb/day. (Polysorbate-80 is a common ingredient of pharmaceutical preparations, available for example as Tween®-80 from Uniqema Americas LLC, Wilmington Delaware.) Alternatively contemplated dissolution reagents in the testing of this paragraph are:

- o a potassium phosphate buffer for pH 3;
- o a sodium citrate buffer for pH 6;
- o a potassium phosphate buffer for pH 7;
- o a potassium phosphate buffer for pH 8;
- o a tris buffer for pH 9;
- o a potassium phosphate buffer for pH 12.

[00116] Optionally, for the pH protective coating or layer 286 in any embodiment, the silicon dissolution rate is less than 160 ppb/day, or less than 140 ppb/day, or less than 120 ppb/day, or less than 100 ppb/day, or less than 90 ppb/day, or less than 80 ppb/day. Optionally, in any embodiment of Figures 13-26 the silicon dissolution rate is more than 10 ppb/day, or more than 20 ppb/day, or more than 30

-28-

ppb/day, or more than 40 ppb/day, or more than 50 ppb/day, or more than 60 ppb/day. Any minimum rate stated here can be combined with any maximum rate stated here for the pH protective coating or layer 286 in any embodiment.

[00117] Optionally, for the pH protective coating or layer 286 in any embodiment the total silicon content of the pH protective coating or layer and barrier coating, upon dissolution into a test composition with a pH of 8 from the vessel, is less than 66 ppm, or less than 60 ppm, or less than 50 ppm, or less than 40 ppm, or less than 30 ppm, or less than 20 ppm.

pH PROTECTIVE COATING OR LAYER PROPERTIES OF ANY EMBODIMENT

Theory of Operation

[00118] The inventors offer the following theory of operation of the pH protective coating or layer described here. The invention is not limited by the accuracy of this theory or to the embodiments predictable by use of this theory.

[00119] The dissolution rate of the SiOx barrier layer is believed to be dependent on SiO bonding within the layer. Oxygen bonding sites (silanols) are believed to increase the dissolution rate.

[00120] It is believed that the pH protective coating or layer bonds with the SiOx barrier layer to "heal" or passivate the SiOx surface and thus dramatically reduces the dissolution rate. In this hypothesis, the thickness of the pH protective coating or layer is not the primary means of protection – the primary means is passivation of the SiOx surface. It is contemplated in any embodiment that a pH protective coating or layer as described in this specification can be improved by increasing the crosslink density of the pH protective coating or layer.

[00121] Optionally in any embodiment, each linear siloxane precursor used to deposit the tie coating or layer and the barrier coating or layer, and optionally also the pH protective coating or layer, can be hexamethylenedisiloxane (HMDSO) or tetramethylenedisiloxane (TMDSO), preferably HMDSO. Optionally in any embodiment, the same linear siloxane precursor is used in each coating process, which can be, for example the tie PECVD coating process, the barrier PECVD

-29-

coating process, and optionally the pH protective PECVD coating process. Using the same siloxane allows for the use of the same coating equipment without the need for valving arrangements to feed a different siloxane, and also avoids manufacturing errors in which the wrong precursor is used in one or more coating steps, which might be difficult to detect after the coating has been applied.

[00122] Optionally in any embodiment, the technology can be further generalized to the use of any plasma enhanced chemical vapor deposition process using any precursors to generate multiple coatings, employing a process as described in this specification or claims.

[00123] Another aspect of the technology is an evacuated blood collection tube comprising a coated vessel as defined above and a closure sealing the lumen. The lumen has a vacuum level sufficient to draw blood from a patient's vein into the lumen.

[00124] Optionally in any embodiment, the evacuated blood collection tube has a shelf life of at least 6 months, the shelf life defined by maintaining at least 90% of its as-manufactured draw volume capacity.

[00125] Optionally in any embodiment, the evacuated blood collection tube has a shelf life under the same definition of at least 12 months, alternatively at least 18 months, alternatively at least 24 months, alternatively from 6 to 12 months, alternatively from 12 to 18 months, alternatively from 18 to 24 months, alternatively from 24 to 30 months, alternatively from 30 to 36 months, alternatively from 36 to 42 months. Longer shelf lives are also contemplated.

[00126] As defined here, the shelf life can be measured by the classic destructive method in which a collection of (typically) identically made evacuated blood collection tubes is exposed to external gas such as air at one atmosphere pressure or oxygen at its usual partial pressure in the atmosphere, and tested at various times for a reduction of the vacuum compared to the as-manufactured level. The shelf life can also be measured by other, typically accelerated measurement methods, for example in which the external pressure is increased, a smaller reduction in vacuum is measured after a shorter period of time and extrapolated to longer times, a test

-30-

reagent or the intended contents of the tube are sealed in the tube, optionally maintained at harsher conditions known to accelerate a diminution in vacuum, and other measurement methods known in the art. One particular accelerated test method contemplated here is an oxygen permeation rate constant test.

[00127] Optionally in any embodiment, the evacuated blood collection tube has a minimum oxygen permeation rate constant (OPRC) of 0.0001, alternatively 0.00016, alternatively 0.0002, alternatively 0.0005, alternatively 0.001, alternatively 0.0016, alternatively 0.002 micromol O₂ / (day x cm² x atm.). Optionally in any embodiment, the evacuated blood collection tube has a maximum OPRC of 0.01, alternatively 0.005, alternatively 0.002 micromol O₂ / (day x cm² x atm.). Any minimum OPRC can be combined with any equal or greater maximum OPRC to construct a range.

[00128] Optionally in any embodiment, the evacuated blood collection tube has an oxygen permeation rate constant of from 0.0001 to 0.01, alternatively from 0.0002 to 0.005, alternatively from 0.0005 to 0.003, alternatively from 0.0016 to 0.003 micromol O₂ / (day x cm² x atm.).

[00129] Optionally in any embodiment, the evacuated blood collection tube has a fluid composition in the lumen, for example comprising a blood anticoagulation reagent. Optionally in any embodiment, the blood anticoagulation reagent comprises, for example, a citrate, for example buffered sodium citrate solution. Other reagents known for use in blood collection tubes are also contemplated for this purpose.

PECVD Process for Trilayer Coating

[00130] The PECVD trilayer coating described in this specification can be applied, for example, as follows for a 1 to 5 mL vessel such as a blood sample collection tube useful as an evacuated blood sample collection tube. Larger or smaller vessels will call for adjustments in parameters that a person of ordinary skill can carry out in view of the teaching of this specification.

-31-

[00131] The apparatus and process used is the PECVD apparatus as described generally in FIG. 2 and the accompanying text and PECVD protocols of U.S. Pat. No. 7,985,188, except that at least the tie or adhesion coating or layer and the barrier coating or layer, and optionally the pH protective layer, are applied in the same apparatus, without breaking vacuum between the application of the adhesion coating or layer and the barrier coating or layer or, optionally, between the barrier coating or layer and the pH protective coating or layer. The entire text and drawings of U.S. Pat. No. 7,985,188 is incorporated here by reference.

[00132] Examples of specific coating parameters that have been used for a 1 mL vessel and 5 mL vial are shown in the PECVD Trilayer Process Specific Parameters Tables 2 (1 mL vial) and 3 (5 mL vial):

PECVD Trilayer Process Specific Parameters Table 2 (1 mL vessel)				
Parameter	Units	Tie	Barrier	Protection
Power	W	70	140	70
TMDSO Flow	sccm	4	None	4
HMDSO Flow	sccm	None	1.56	None
O ₂ Flow	sccm	2	20	2
Argon Flow	sccm	80	0	80
Ramp Time	seconds	None	None	None
Deposition Time	seconds	2.5	20	10
Tube Pressure	Torr	1	0.59	1

-32-

PECVD Trilayer Process Specific Parameters Table 3 (5 mL vial)				
Parameter	Units	Adhesion	Barrier	Protection
Power	W	20	40	20
TMDSO Flow	sccm	2	0	2
HMDSO Flow	sccm	0	3	0
O ₂ Flow	sccm	1	50	1
Argon Flow	sccm	20	0	20
Ramp Time	seconds	0	2	2
Deposition Time	seconds	2.5	10	10
Tube Pressure	Torr	0.85	1.29	0.85

[00133] The O-parameter and N-parameter values for the pH protective coating or layer applied to the 1 mL vessel as described above are 0.34 and 0.55, respectively.

[00134] The O-parameter and N-parameter values for the pH protective coating or layer applied to the 5 mL vessel are 0.24 and 0.63, respectively.

[00135] Referring to FIGS. 1, 2, and 4-6, another aspect of the invention is a method of processing a vessel 210 to apply a tie coating or layer 289, a barrier coating or layer 288, and optionally one or more additional coatings or layers. Optionally in any embodiment, the vessel 210 can be configured as a sample collection tube, for example an evacuated blood collection tube; a sample storage tube, a centrifuge tube, a chromatography vial, or tubing. The coated vessel can be formed by a process comprising several steps.

[00136] To carry out the process, a vessel 210 is provided including a wall 214 consisting essentially of thermoplastic polymeric material defining a lumen 212.

-33-

Optionally in any embodiment, the wall includes a polyester, polyethylene terephthalate (PET), polyethylene naphthalate (PEN); a polyolefin, cyclic olefin polymer (COP), cyclic olefin copolymer (COC), polypropylene (PP), or a polycarbonate, preferably COP. Optionally in any embodiment, the vessel lumen has a capacity of from 2 to 12 mL, optionally from 3 to 5 mL, optionally from 8 to 10 mL.

[00137] The wall 214 has an inside surface 303 facing the lumen and an outside surface 305..

[00138] A partial vacuum is drawn in the lumen. While maintaining the partial vacuum unbroken in the lumen, the tie coating or layer 289 of SiOxCy is applied by a tie PECVD process comprising applying sufficient power (alternatively the same concept is referred to in this specification as "energy") to generate plasma within the lumen while feeding a gas comprising a linear siloxane precursor, optionally oxygen, and optionally an inert gas diluent. The values of x and y are as determined by X-ray photoelectron spectroscopy (XPS).

[00139] Then, while maintaining the partial vacuum unbroken in the lumen, the plasma is extinguished, which has the effect of stopping application of the tie coating or layer of SiOxCy. Optionally in any embodiment, after the plasma used in the tie PECVD coating process is extinguished and before the barrier PECVD coating process is commenced, the feed of the gas employed in the tie PECVD coating process can be stopped. A tie coating or layer of SiOxCy, for which x is from about 0.5 to about 2.4 and y is from about 0.6 to about 3, is produced on the inside surface 303 as a result.

[00140] Later during the process, while still maintaining the partial vacuum unbroken in the lumen, the barrier coating or layer 288 is applied by a barrier PECVD process comprising applying sufficient power (alternatively the same concept is referred to in this specification as "energy") to generate plasma within the lumen while feeding a gas comprising a linear siloxane precursor and oxygen

[00141] Optionally in any embodiment, the power provided to generate plasma within the lumen for applying the barrier coating or layer in a 1-Up coater is from 30

-34-

to 80 watts, optionally from 40 to 80 watts, optionally from 50 to 80 watts, optionally from 55 to 65 watts, or optionally in a 4-Up coater is from 175 to 200 watts, optionally from 180 to 190 watts.

[00142] Optionally in any embodiment, the plasma generated for applying the barrier coating or layer is applied for 12 to 20 seconds, optionally for 15 to 20 seconds.

[00143] Optionally in any embodiment, the barrier coating or layer is applied using a siloxane precursor feed rate, optionally of HMDSO, of from 0.5 to 2 sccm, optionally 0.7 to 1.3 sccm.

[00144] Optionally in any embodiment, the barrier coating or layer is applied using a pressure of from 0.5 to 3.5 Torr, optionally from 1 to 2.5 Torr.

[00145] Optionally after applying the barrier coating or layer, while maintaining the partial vacuum unbroken in the lumen, the plasma is extinguished, which has the effect of stopping application of the barrier coating or layer. Optionally in any embodiment, after the plasma used in the barrier PECVD coating process is extinguished and before the optional pH protective PECVD coating process, if used, is commenced, the feed of the gas employed in the barrier PECVD coating process can be stopped. A barrier coating or layer of SiO_x , wherein x is from 1.5 to 2.9 as determined by XPS is produced between the barrier coating or layer and the lumen as a result of barrier coating.

[00146] Then optionally, while maintaining the partial vacuum unbroken in the lumen, the pH protective coating or layer 286 of SiO_xC_y is later applied by a pH protective PECVD process. In this formula, x is from about 0.5 to about 2.4 and y is from about 0.6 to about 3, each as determined by XPS. The pH protective coating or layer is optionally applied between the barrier coating or layer and the lumen, by a pH protective PECVD coating process. The pH protective PECVD process comprises applying sufficient power (alternatively the same concept is referred to in this specification as "energy") to generate plasma within the lumen while feeding a gas comprising a linear siloxane precursor, optionally oxygen, and optionally an inert gas diluent.

-35-

[00147] Surprisingly, as a result of this processing, the coated vessel 210 made by this process has a lower gas permeation rate constant into the lumen than a corresponding vessel 210 made by the same process except breaking the partial vacuum in the lumen between applying the tie coating or layer and applying the barrier coating or layer.

[00148] Alternatively, the coated vessel made by this process including the optional steps has a lower gas permeation rate constant into the lumen than a corresponding vessel made by the same process except breaking the partial vacuum in the lumen between applying the tie coating or layer and applying the barrier coating or layer, and also breaking the partial vacuum in the lumen between applying the barrier coating or layer and the pH protective coating or layer. Optionally in any embodiment, the coated vessel 210 has an oxygen permeation rate constant (OPRC) of from 0.002 to 0.1, optionally from 0.01 to 0.1, optionally from 0.14 to 0.05, optionally from 0.002 to 0.02, optionally from 0.003 to 0.12 $\mu\text{mol}/\text{day}/\text{cm}^2/\text{atm}$.

[00149] Optionally in any embodiment, the coated vessel 210 has an oxygen transfer rate of from 0.5 to 12, optionally from 3 to 22, optionally from 3.4 to 12, optionally from 0.5 to 3, optionally from 0.7 to 2 $\text{cc}/\text{m}^2/\text{day}$.

[00150] Optionally in any embodiment, the wall has a water vapor transmission rate of less than 2.5 $\text{g}/\text{m}^2/\text{day}$ at 50°C and 90% relative humidity.

[00151] Optionally in any embodiment, the PECVD process for applying the tie coating or layer, the barrier coating or layer, and/or the pH protective coating or layer, or any combination of two or more of these, is carried out by applying pulsed power (alternatively the same concept is referred to in this specification as "energy") to generate plasma within the lumen.

[00152] Alternatively, the tie PECVD coating process, or the barrier PECVD coating process, or the pH protective PECVD coating process, or any combination of two or more of these, can be carried out by applying continuous power to generate plasma within the lumen.

-36-

[00153] As a still further alternative, pulsed power can be used for some steps, and continuous power can be used for others. For example, when preparing a trilayer coating or layer composed of a tie coating or layer, a barrier coating or layer, and a pH protective coating or layer, an option specifically contemplated for the tie PECVD coating process and for the pH protective PECVD coating process is pulsed power, and an option contemplated for the corresponding barrier layer is using continuous power to generate plasma within the lumen.

[00154] Optionally in any embodiment, the present process further includes the subsequent step of providing a fluid composition in the lumen.

[00155] Optionally in any embodiment, the fluid composition includes a blood anticoagulation reagent, for example, buffered sodium citrate solution.

[00156] Another aspect of the current invention relates to a sample collection tube incorporating stopper retention features. The following description will focus on blood sample collection tubes, but is equally applicable to tubes for collecting other types of medical samples.

[00157] It is sometimes desirable or necessary to collect a sample of blood or another body fluid in one location, then pack the sample to prepare it for transportation to another location, for example to collect a large number of samples from geographically diverse locations at a central laboratory for analysis, or at a central repository for storage after analysis. Since blood or other body fluids collected for medical diagnostic use frequently are infectious substances, it is important to pack the sample carefully so it will not leak during transportation.

[00158] One particular aspect of medical sample collection bearing on this problem is that a medical sample in a stoppered vessel is commonly contained at substantially ambient atmospheric pressure at the time and place of collection. Even a blood sample collected in an evacuated blood collection tube commonly is at or near atmospheric pressure just after collection, as the initial vacuum in the sample tube is consumed by drawing the sample into the vessel.

-37-

[00159] According to 49 CFR 173.196 relating to transportation of Category A and B Infectious Substances, the packing for infectious substances "must be capable of withstanding, without leakage, an internal pressure producing a pressure differential of not less than 95 kPa (0.95 bar, 14 psi)." This translates to an altitude of 70,000 feet.

[00160] Accordingly, standard sample collection tubes desirably are designed to satisfy this transportation standard, so they will be useful for transporting medical samples that potentially are infectious agents.

[00161] Several aspects of this invention are various adaptations of the vessel 210 shown in FIGS. 1-2 and 4-6 specially adapting it to carry samples without leakage in accord with the requirements of 49 CFR 173.196.

[00162] Refer now to FIGS. 4-6. In the illustrated embodiment, the vessel 210 can have a thermoplastic wall 214, although the vessel 210 instead could be made of glass, thermoset plastic, or other materials without limitation, although transparent materials are commonly preferred. The vessel 210 has a top 295 defining an opening, an inside surface 303 defining a lumen 212, an outside surface 305, and a stopper contact area 291 on the inside surface 303 adjacent to the top 295.

[00163] One retention feature of the vessel, which may be used alone or in combination with other features, is that the stopper contact area 291 is tapered inward between 0 and 1.3 degrees, for example, which is less than the typical molding taper for a blood sample collection tube. "Tapered inward" means that the diameter of the lumen 212 is reduced regularly going axially from the top (nearest the top 295 of the vessel) to the bottom of the stopper contact area 291, so the inside surface 303 in the stopper contact area 291 defines the sidewall of a truncated cone. For the present purpose, a "taper" of exactly zero degrees is defined as "between" 0 and 1.3 degrees, even though a "taper" of zero is in fact a cylinder that does not taper at all. Additionally, any taper greater than zero degrees to any extent and not greater than 1.3 degrees is within this range of the invention, including a taper of exactly 1.3 degrees. In other words, "between" two numerical limits according to the present definition is inclusive of both limits.

-38-

[00164] It is also contemplated that a taper of zero is not the absolute lower limit, and a negative taper (tapered outward) can function according to the present invention, although it is less preferred because in some instances fabrication of a negatively tapered part will require more specialized, although well known, techniques, such as a two- or multi-part core, machining, or lost-wax casting.

[00165] Alternatively, the stopper contact area 291 can be tapered inward between 0 and 1 degree, optionally between 0 to 0.9 degree, optionally between 0 to 0.8 degree, optionally between 0 to 0.7 degree, optionally between 0 to 0.6 degree, optionally between 0 to 0.5 degree, optionally between 0.3 to 1.3 degrees, optionally between 0.3 to 1 degree, optionally between 0.3 to 0.9 degree, optionally between 0.3 to 0.8 degree, optionally between 0.3 to 0.7 degree, optionally between 0.3 to 0.6 degree, optionally between 0.3 to 0.5 degree, optionally between 0.5 to 1.3 degrees, optionally between 0.5 to 1 degree, optionally between 0.5 to 0.9 degree, optionally between 0.5 to 0.8 degree, optionally between 0.5 to 0.7 degree, optionally between 0.5 to 0.6 degree, optionally 0.5 degree.

[00166] Preferably the tapering change is only in the stopper contact area 291. The tapering reduction preferably is not substantially below the stopper contact area 291, as that would change the internal volume. If a change in the internal volume is not important in a given instance, however, the tapering change can extend further than the stopper contact area 291. Additionally, the tapering reduction does not need to extend throughout the entire stopper contact area 291, as tapering reduction over at least a portion of the stopper contact area 291 may be sufficient to provide the desired retention.

[00167] Additionally, in any embodiment, to implement limitation of the tapering reduction to the stopper contact area 291, at least a portion of the inside surface 303 of the evacuated blood collection tube located below the stopper contact area 291, is tapered at least 0.7 degree, optionally at least 1 degree, optionally at least 1.5 degree, and as a separately selected option can be tapered at least 0.1 degree more than the stopper contact area 291. A greater taper below the stopper contact area

-39-

291 has the benefit of easing simple removal of a one-part core from a mold when the vessel 210 is injection molded.

[00168] The effect achieved by reducing the inward taper in the stopper contact area 291 is to reduce or eliminate the tendency of the stopper 216 to loosen if it moves upward with respect to the stopper contact area 291. A resilient stopper compressed by the stopper contact area 291 is biased to expand laterally outward, and thus to move upward toward a region of slightly larger diameter within the stopper contact area 291. This biasing force is reduced by reducing the taper in the stopper contact area 291.

[00169] Another retention feature of the vessel 210, which may be used alone or in combination with other retention features, is that a retention lip 293 projects radially inward from the inside surface 305. The inside surface 305 includes a stopper contact area 291 adjacent to and below the retention lip 293. The retention lip 293 functions by bearing down on a stopper 216 lodged in the stopper contact area, requiring the stopper 216 to be further compressed if it is to pass axially across the retention lip 293.

[00170] Optionally in any embodiment, the retention lip 293 includes an upper ramp 301 defining an inward taper, optionally a curved inward taper, optionally a convexly curved inward taper, relative to the opening at the top 295, the upper ramp having a lower end 307. Optionally in any embodiment, the retention lip further includes a lower ramp 299 defining an outward taper, optionally a curved outward taper, optionally a convexly curved outward taper, relative to the lower end 307.

[00171] Optionally in any embodiment the stoppers 216 are siliconized in a tumbler before use to prevent the stoppers 216 from sticking to each other.

[00172] Several other features that apply to each disclosed embodiment are the following. Optionally in any embodiment, the evacuated blood collection tube includes a closure sealing the lumen. Optionally, the closure maintains a vacuum level in the lumen, relative to ambient pressure at sea level, sufficient to draw blood from a patient's vein into the lumen.

-40-

[00173] Optionally in any embodiment, the closure remains seated in the stopper contact area 291 at a vacuum level of 97.5 kPa below ambient pressure.

[00174] Optionally in any embodiment, the evacuated blood collection tube has a shelf life of at least 6 months. As used in this context, the "shelf life" is defined by the amount of time after evacuation the tube maintains a draw volume capacity of at least 90% of the draw volume capacity of a newly evacuated vessel 210 of the same kind.

[00175] Optionally in any embodiment, the evacuated blood collection tube has a shelf life of from 6 to 12 months, alternatively from 12 to 18 months, alternatively from 18 to 24 months, alternatively from 24 to 30 months, alternatively from 30 to 36 months, alternatively from 36 to 42 months.

[00176] Optionally in any embodiment, the evacuated blood collection tube further includes a fluid composition in the lumen, alternatively an aqueous fluid composition, alternatively including a blood anticoagulation reagent, for example, buffered sodium citrate solution.

[00177] Optionally in any embodiment, the evacuated blood collection tube has an oxygen permeation rate constant of from 0.0001 to 0.01, alternatively from 0.0002 to 0.005, alternatively from 0.0005 to 0.003, alternatively from 0.0016 to 0.003 micromol O₂ / (day x cm² x atm.).

[00178] Optionally in any embodiment, the evacuated blood collection tube has a minimum oxygen permeation rate constant of 0.0001, alternatively 0.00016, alternatively 0.0002, alternatively 0.0005, alternatively 0.001, alternatively 0.0016, alternatively 0.002 micromol O₂ / (day x cm² x atm).

[00179] Optionally in any embodiment, the evacuated blood collection tube has a maximum oxygen permeation rate constant of 0.01, alternatively 0.005, alternatively 0.002 micromol O₂ / (day x cm² x atm)

[00180] Optionally in any embodiment, the evacuated blood collection tube has a water vapor transmission rate of less than 2.5 g/m²/day at 50°C and 90% relative humidity.

-41-

EXAMPLE 1

[00181] A trilayer coating as described in this specification is applied by adjusting the flows of a single organosilicon monomer (HMDSO) and oxygen and also varying the PECVD generating power between each layer (without breaking vacuum between any two layers).

[00182] The vessel (here a 6 mL COP vial) is placed on a vessel holder, sealed, and a vacuum is pulled within the vessel. Vials are used to facilitate storage while containing fluid as indicated below. Proportional results are contemplated if blood sample collection tubes are used. After pulling vacuum, the gas feed of precursor, oxygen, and argon is introduced, then at the end of the "plasma delay" continuous (i.e. not pulsed) RF power at 13.56 MHz is turned on to form the tie coating or layer. Then power is turned off, gas flows are adjusted, and after the plasma delay power is turned on for the second layer -- an SiO_x barrier coating or layer. This is then repeated for a third layer before the gases are cut off, the vacuum seal is broken, and the vessel is removed from the vessel holder. The layers are put down in the order of Tie then Barrier then pH Protective. The process settings are as shown in Table 4:

TABLE 4	O ₂ (sccm)	Ar (sccm)	HMDSO (sccm)	Power (W)	Deposition Time (sec)
Tie	1	40	2	20	2.5
Barrier	100	0	1	60	15
pH Protective	1	40	2	20	10

[00183] As a control, a similar coating process is carried out again, except that when each layer has been deposited the vacuum is broken (causing a "vacuum break") by introducing ambient air into the vessel. After each vacuum break, the vessel is evacuated before applying the next layer.

[00184] Each vial except those measured for oxygen permeation rate constant initially is charged with a standard amount of an aqueous phosphate-buffered

-42-

solution (PBS) of pH 9 at 40°C and held for the amount of time, in days, indicated in FIG. 3. Then, after each time interval indicated in FIG. 3, groups of vials are cooled, drained, and measured for oxygen permeation rate constant (OPRC) at ambient temperature, reported as μmol (micromole) $\text{O}_2 / (\text{day} \times \text{cm}^2 \times \text{atm.})$, with the results shown in FIG. 3 and tabulated (summary) in Table 5.

[00185] Vessels prepared without vacuum breaks (“all combined” runs on the right side of FIG. 3) are compared to the vessels prepared with vacuum breaks (“all separate” runs on the left side of FIG. 3), respecting their oxygen permeation rate constants.

TABLE 5	STORAGE TIME, Days				
	0	3	7	14	28
Mean OPRC, All Combined	0.00287	0.00518	0.00274	0.00518	0.00540
Std. Dev.	0.00123	0.00128	0.00094	0.00087	0.00087
Mean OPRC, All Separate	0.00774	0.01563	0.00959	0.01543	0.01827
Std. Dev.	0.00138	0.00425	0.00449	0.00334	0.00720

[00186] Surprisingly, as shown in FIG. 3 and the tabulated summary of Table 5, at each storage time the vials processed without intermediate vacuum breaks have much lower (better) OPRC than those processed with intermediate vacuum breaks. It should be noted that the usual oxygen permeation rate constant of corresponding uncoated vials is about $0.122 \mu\text{mol O}_2 / (\text{day} \times \text{cm}^2 \times \text{atm.})$, so the vials processed without intermediate vacuum breaks have about 5% of the OPRC of uncoated vials after four weeks of storage.

EXAMPLE 2

[00187] Similar testing on a 6 mL blood sample collection tube is carried out, and in one test the OPRC of a tube coated according to the present “combined” process is $0.00344 \mu\text{mol O}_2 / (\text{day} \times \text{cm}^2 \times \text{atm.})$, with a standard deviation of 0.0011.

[00188] A parallel test is carried out in which all conditions are the same except that, instead of the plasma-creating power (alternatively the same concept is

-43-

referred to in this specification as "energy") being applied continuously, it is applied in pulses having a frequency of 5 Hz and a duty cycle of 50%. This means that the full power indicated (W) is applied for 0.1 second, then power is off for 0.1 second, then back on for 0.1 second, then back off for 0.1 second. The result is an OPRC of 0.00380 $\mu\text{mol O}_2 / (\text{day} \times \text{cm}^2 \times \text{atm.})$, with a standard deviation of 0.0015 under pulsed power. In either case, the OPRC is about 8% of the OPRC of a similar uncoated vessel.

EXAMPLE 3

[00189] A test similar to Example 1 is carried out, except that, instead of the plasma-creating power (alternatively the same concept is referred to in this specification as "energy") being applied continuously, it is applied in pulses having a frequency of 5 Hz and a duty cycle of 50%, repeating for the total time indicated in Table 6.

TABLE 6	O ₂ (sccm)	Ar (sccm)	HMDSO (sccm)	Power (W)	Deposition Time (sec)	Frequency (Hz)	Duty Cycle (%)
Tie	1	40	2	20	2.5	5	50
Barrier	100	0	1	60	15	5	50
Protective	1	40	2	20	10	5	50

[00190] OPRC results approximately proportional to those obtained with continuous power are observed.

EXAMPLE 4

[00191] This study was carried out to determine the effect of applied electrical power during the coating process on the resulting Oxygen Transmission Rates (OTR) or Oxygen Permeation Rate Constant (OPRC) of the coating or layer.

[00192] A trilayer coating or layer as described in this specification was applied to a vessel (here a 4 mL COP blood sample collection tube, and the same in other tests except as otherwise indicated) by applying a tie layer using the process settings shown in Table 7 for a 1-Up unit, then a barrier layer using the process settings shown in Table 8, and finally a pH protective layer using the process

-44-

settings shown in Table 7 for a 1-Up unit. The 1-Up coating unit was a PECVD station where vacuum supply, process gases, and RF power were supplied to one individual article to deposit the barrier coating or layer system on the inside of said article.

[00193] The PECVD generating power and other process settings were changed between each layer of the trilayer coating or layer (without breaking vacuum between any two layers). During the trilayer coating process, the power for the tie layer and the pH protective layer (i.e. the first and the third layer) was kept unchanged. The power for the barrier coating or layer was varied as shown in Table 8 to see how it affected the barrier performance (expressed as oxygen transmission rate (OTR) or oxygen permeation rate constant (OPRC)).

Table 7. Coating Parameters for Tie layer and pH Protective Layer

1-Up Adhesive/Protective Process									
Layer	Argon sccm	Oxygen sccm	HMDSO sccm	Power (W)	Time (s)	Pressure	Pulsing	Hz	Duty Cycle
Adhesive	40	1	2	35	5	1.9 Torr	Yes	5	50%
Protective	40	1	2	35	10	1.9 Torr	Yes	5	50%

-45-

4-Up Adhesive/Protective Process									
Layer	Argon sccm	Oxy- gen sccm	HMDSO sccm	Power (W)	Time (s)	Pressure	Pulsing	Hz	Duty Cycle
Adhesive	40	2	4	150	5	1.9 Torr	Yes	5	50%
Protective	40	2	4	150	10	1.9 Torr	Yes	5	50%

[00194] The coating process was carried out as follows. The vessel was placed on a vessel holder, sealed, and a vacuum was pulled within the vessel. After pulling vacuum, the gas feed of precursor, oxygen, and argon was introduced, then after a plasma delay, RF power was turned on in pulses to generate plasma and form the tie coating or layer. The power was applied in pulses having a frequency of 5 Hz and a duty cycle of 50%. This means that the full power indicated (W) was applied for 0.1 second, then power was off for 0.1 second, then back on for 0.1 second, then back off for 0.1 second. Then power was turned off, gas flows were adjusted, and after the plasma delay, the RF power was turned on in the same unit for the second layer -- a SiOx barrier coating or layer. The RF power for the barrier coating or layer was applied continuously. The same pulsed RF power as for the tie coating or layer was then repeated for a third layer before the gases were cut off, the vacuum seal was broken, and the vessel was removed from the vessel holder. The layers were put down in the order of tie then barrier then pH protective.

[00195] Each blood sample collection tube was measured for oxygen permeation rate constant (OPRC) at ambient temperature, reported as μmol (micromole) O₂ / (day x cm² x atm) with the results of OPRC and OTR shown in Figures 3A and 3B and tabulated in Table 8. "Part pressure" in Table 8 is the total pressure of all constituents within one part or vessel.

[00196] Table 8 shows that higher electrical power results in a barrier coating or layer with lower OPRC (i.e. better barrier performance). After 60 W, continued increasing of electrical power does not improve the barrier performance any more, as dependent on the volume of the article in this case blood sample collection tube.

-46-

Table 8. Effect Of Electrical PowerHMDSO (sccm)=1.0, O₂ (sccm)=100.0, Time(s)=10.0

Permeance (OPRC ₂ μmol/day/cm ² /atm)		Oxygen Transmission Rate (OTR, cc/m ² /day)		Process Information		
Avg.	2*St.Dev.	Avg.	2*St.Dev.	Power (W)	Part Pressure (Torr)	Unit
0.105	0.0053	25.74	1.31	20.0	3.92	1-Up
0.090	0.0152	21.90	3.71	30.0	3.92	1-Up
0.049	0.0392	12.06	9.58	40.0	3.92	1-Up
0.018	0.0054	4.47	1.33	50.0	3.92	1-Up
0.014	0.0031	3.45	0.76	60.0	3.92	1-Up
0.017	0.0031	4.05	0.77	70.0	3.92	1-Up
0.017	0.0096	4.22	2.34	80.0	3.92	1-Up
0.16	0.0052	38.69	1.27	Uncoated		

EXAMPLE 5

[00197] This study was to determine the effect of coating time on the resulting Oxygen Transmission Rates (OTR) or Oxygen Permeation Rate Constant (OPRC) of the coating or layer.

[00198] A trilayer coating or layer as described in this specification was applied, adjusting the coating time (without breaking vacuum between any two layers), and the resulting OPRC and OTR were compared. During the trilayer process, the coating parameters for tie layer and pH protective layer (i.e. the first and the third layer) were those of Table 7 for a 1-Up unit. The coating parameters for the barrier coating or layer (i.e. the second layer) were those of Table 9. The coating time for the barrier coating or layer was varied as shown in Table 9 to see how it affected the barrier performance (expressed as oxygen transmission rate (OTR) or oxygen permeation rate constant (OPRC)). The results are shown in Table 9 and Figures 5A and 5B.

-47-

Table 9. Effect Of Coating Time

HMDS(sccm)=1.0, O₂(sccm)=100, Power(w)=60

Permeance μmol/day/cm ² /atm		Oxygen Transmission Rate cc/m ² /day		Process Information		
Avg.	2*St.Dev.	Avg.	2*St.Dev.	Time (s)	Part Pressure (Torr)	Unit
0.0150	0.0063	3.68	1.53	10.0	3.92	1-Up
0.0031	0.0025	0.76	0.62	15.0	3.92	1-Up
0.0029	0.0017	0.71	0.42	20.0	3.92	1-Up

[00199] The results show that the barrier coating or layer performance was improved with the increase of coating time until the time reached 15 seconds. After 15 seconds, continued increasing the coating time did not improve the barrier performance any more, as dependent on the volume of the article in this case blood tube.

EXAMPLE 6

[00200] This study was to determine the effect of feeding rate of the coating or layer precursor HMDSO during the barrier coating process on the resulting Oxygen Transmission Rates (OTR) or Oxygen Permeation Rate Constant (OPRC) of the trilayer coating or layer.

[00201] A trilayer coating or layer as described in this specification was applied essentially as before, using the conditions of Table 7 for the tie coating or layer and pH protective coating or layer, and the conditions of Table 10 for the barrier coating or layer, without breaking vacuum between any two layers. The effects of different HMDSO feeding rates for the barrier layer were compared.

[00202] These tests were carried out both using the 1-Up unit previously described and a 4-Up unit. The 4-Up unit was similar to the 1-Up unit, but the vacuum supply, process gases, and RF power were uniformly split and supplied uniformly to four individual vessels. By maintaining uniformity with vacuum supply and process gases, the pressure within each vessel of a 4-Up remains the same as the single vessel of a 1-Up.

-48-

[00203] During the trilayer coating process, HMDSO feeding rate for tie layer and pH protective layer (i.e. the first and the third layer) were kept unchanged. HMDSO feeding rate for the barrier coating or layer was varied to see how it affects the barrier performance (expressed as oxygen transmission rate (OTR) or oxygen permeation rate constant (OPRC)).

[00204] The results are shown in Table 10. The barrier coating or layer performance was improved with decrease of HMDSO feeding rate until the feeding rate reached 1 sccm. After 1 sccm, continued lowering HMDSO feeding rate did not improve the barrier performance any more, as dependent on the volume of the article in this case blood sample collection tube.

Table 10. Effect Of HMDSO feeding rate

Time(s)=10.0, O2(sccm)=100, Power(w)=60

Permeance $\mu\text{mol/day/cm}^2/\text{atm}$		Oxygen Transmission Rate $\text{cc/m}^2/\text{day}$		Process Information		
Avg.	2*St.Dev.	Avg.	2*St.Dev.	HMDSO (sccm)	Part Pressure (Torr)	Unit
0.117	0.0130	28.63	3.18	3.0	3.92	1-Up
0.0267	0.0163	6.52	3.98	2.0	3.92	1-Up
0.0041	0.0019	0.99	0.46	1.0	3.92	1-Up
0.0090	0.0026	2.20	0.63	0.5	3.92	1-Up

Time(s)=15.0, O2(sccm)=100, Power(w)=60

Permeance $\mu\text{mol/day/cm}^2/\text{atm}$		Oxygen Transmission Rate $\text{cc/m}^2/\text{day}$		Process Information			
Avg.	2*St.Dev.	Avg.	2*St.Dev.	HMDSO (sccm)	Power (W)	Part Pressure (Torr)	Unit
0.127	0.0050	31.01	1.22	6.0	145.0	3.92	4-Up
0.0746	0.0050	18.24	1.22	3.0	145.0	3.92	4-Up
0.0341	0.0132	8.35	3.24	1.0	175.0	3.92	4-Up

EXAMPLE 7

[00205] In this example, the power, HMDSO feeding rate, and coating time were varied to optimize the coating conditions to obtain the best barrier coating or layer performance (i.e. the lowest OPRC and OTR). The process information is shown in Table 7 (4-Up) for the tie coating or layer and pH protective coating or layer and Table 11 for the barrier layer. The results are shown in Table 11. The best results

-49-

were achieved in the second test with a feed of 1.0 sccm HMDSO, power of 185.0 watts, and time of 15.0 sec.

-50-

Table 11. Effect of Power, HMDSO Feeding Rate and TimeO₂(sccm)=100

Permeance μmol/day/cm ² /atm		Oxygen Transmission Rate cc/m ² /day		Process Information				
Avg.	2*St.Dev	Avg	2*St.Dev.	HMDS O (sccm)	Power (W)	Time (s)	Part Pressure (Torr)	Unit
0.053	0.0264	12.85	6.45	1.0	175.0	10.0	3.92	4-Up
0.0162	0.0023	3.97	0.57	1.0	185.0	15.0	3.92	4-Up
0.0234	0.0050	5.73	1.22	1.0	185.0	10.0	3.92	4-Up
0.0215	0.0044	5.26	1.08	2.0	200.0	15.0	3.92	4-Up

EXAMPLE 8

[00206] This study was to determine the effect of applied pressure during the coating process on the resulting Oxygen Transmission Rates (OTR) or Oxygen Permeation Rate Constant (OPRC) of the trilayer coating or layer. Compared to Examples 4-7 wherein the applied pressure was 3.92 torr, in Example 8, the applied pressure was 1.6 torr. The results were shown in Table 12.

Table 12. Effect Of PressureO₂ (sccm)=75.0, Power(w)= 200

Permeance μmol/day/cm ² /atm		Oxygen Transmission Rate cc/m ² /day		Process Information			
Avg.	2*St.Dev.	Avg.	2*St.Dev.	HMDSO (sccm)	Time (s)	Part Pressure (Torr)	Unit
0.0043	0.0028	1.04	0.69	1.0	10.0	1.60	4-Up
0.0044	0.0084	1.08	2.06	1.5	10.0	1.60	4-Up
0.0049	0.0034	1.20	0.83	1.0	15.0	1.60	4-Up
0.0039	0.0040	0.96	0.99	1.5	15.0	1.60	4-Up

[00207] The results show that lower pressure improved the barrier coating or layer performance.

EXAMPLE 9

[00208] This was a Pressure Differential Test and the testing conditions were set to mimic ambient atmospheric pressure at an altitude of 70,000 feet. This testing

-51-

was done to determine if the trilayer coated bloodtubes with the retention features described in the specification can stay intact and endure the pressure change. This testing was important to predict if the bloodtubes of this invention were fit for transporting infectious blood samples. It was a pass/fail testing.

[00209] 10 mL trilayer coated COP blood sample collection tubes including both retention features described above (a retention lip 293 and a taper of about 0.5" in the stopper contact area 291) were sealed with stoppers which had been siliconized (coated with silicone oil) in a tumbler to prevent them from sticking to each other. The sealed blood sample collection tubes were evacuated and filled with $9.33 \text{ mL} \pm 0.03 \text{ mL}$ of red colored water before they were placed upright and inverted into a 700 mL beaker, which was then placed within a metal canister for pressurization/vacuum. A maximum quantity of 10 filled blood sample collection tubes were tested at once. Once the metal canister was sealed, the vacuum valve was opened slowly to reduce the pressure to -28.8 in. Hg gauge (-14.1 psig, or a pressure differential of 97.5 kPa). This method approximates the effect of filling and stoppering the vessels at sea level ambient pressure, then elevating them to 70,000 feet above sea level, since a standardized pressure difference is applied regardless of the elevation or barometric pressure where the tubes are filled.

[00210] Filled blood sample collection tube samples were held at this vacuum level for 30 minutes. After the 30 minutes passed, the vacuum level was slowly raised to ambient pressure. Samples were then removed and inspected for stopper movement and leaks.

[00211] The blood sample collection tubes with the retention features described in the specification passed Pressure Differential Testing with no leaks. The same blood sample collection tubes without the retention features failed the Pressure Differential Testing.

WE CLAIM:

1. An evacuated blood collection tube comprising:
a thermoplastic vessel wall; and
a stopper;
the thermoplastic vessel wall having
a top defining an opening,
an inside surface defining a lumen, the inside surface having one or more coatings applied by PECVD,
an outside surface, and
a stopper contact area adjacent to the top, the stopper contact area being a portion of the inside surface that contacts the stopper;
the stopper being seated in the stopper contact area and sealing the lumen;
wherein the stopper contact area is tapered inward between 0 and 1.3 degrees and the entirety of the inside surface below the stopper contact area is tapered inward at least 0.1 degree more than the stopper contact area; and
wherein the stopper contact area is continuous with the inside surface below the stopper contact area.
2. The evacuated blood collection tube of claim 1, in which the entirety of the inside surface below the stopper contact area is tapered at least 1.5 degrees.
3. The evacuated blood collection tube of claim 1, the stopper maintaining a vacuum level in the lumen, relative to ambient pressure at sea level, sufficient to draw blood from a patient's vein into the lumen.
4. The evacuated blood collection tube of claim 3, in which the stopper remains seated in the stopper contact area at a vacuum level of 97.5 kPa below ambient pressure.
5. The evacuated blood collection tube of claim 3, having a shelf life of at least 6 months, the shelf life defined by the amount of time after evacuation the tube maintains a draw volume capacity of at least 90% of the draw volume capacity of a newly evacuated vessel of the same kind.
6. The evacuated blood collection tube of claim 3, further comprising a fluid composition in the lumen.
7. The evacuated blood collection tube of claim 6, wherein the fluid composition comprises a blood anticoagulation agent.
8. The evacuated blood collection tube of claim 7, wherein the blood anticoagulation agent is a buffered sodium citrate solution.
9. The evacuated blood collection tube of claim 3, having an oxygen permeation rate constant of from 0.0001 to 0.01 micromol O₂/(day×cm²×atm).

10. The evacuated blood collection tube of claim 3, in which the wall has a water vapor transmission rate of less than 2.5 g/m²/day at 50° C. and 90% relative humidity.
11. The evacuated blood collection tube of claim 1, wherein the inside surface comprises:
a barrier layer of SiO_x applied by a PECVD coating process, wherein x is from 1.5 to 2.9 as determined by XPS, and
at least one of:
a tie layer of SiO_xC_y applied by a PECVD coating process, and
a pH protective layer of SiO_xC_y applied by a PECVD coating process.
12. The evacuated blood collection tube of claim 1, wherein the inside surface comprises:
a tie layer of SiO_xC_y applied by a PECVD coating process,
a barrier layer of SiO_x applied by a PECVD coating process, wherein x is from 1.5 to 2.9 as determined by XPS, between the tie coating or layer and the lumen, and
a pH protective layer of SiO_xC_y applied by a PECVD coating process, wherein x is from about 0.5 to about 2.4 and y is from about 0.6 to about 3, each as determined by XPS, between the barrier layer and the lumen.
13. The evacuated blood collection tube of claim 1, in which the stopper contact area is tapered inward between 0.3 and 1 degree.

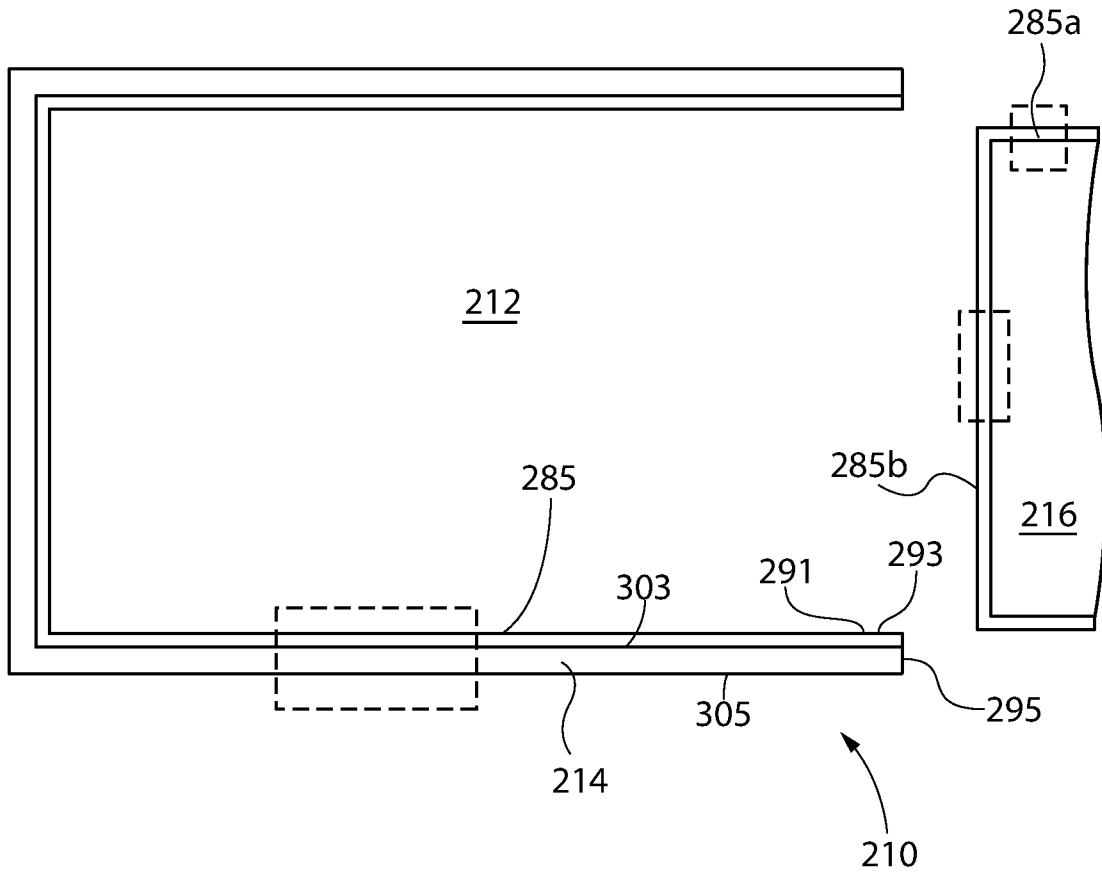

FIG. 1

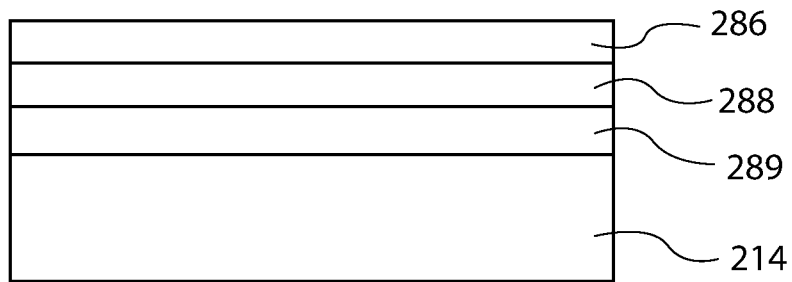

FIG. 2

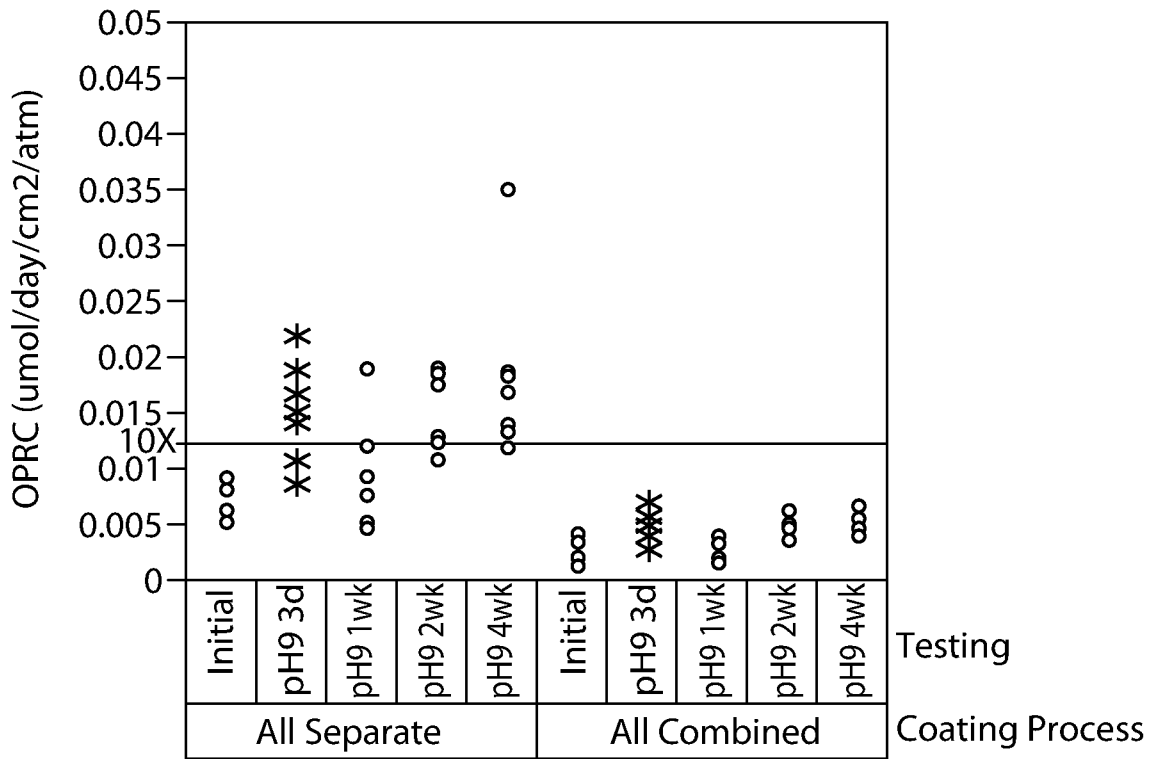

FIG. 3

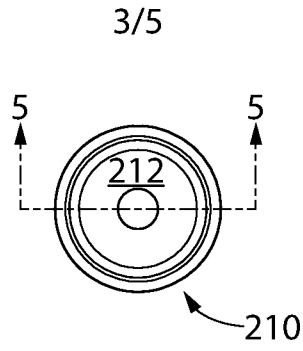

FIG. 4

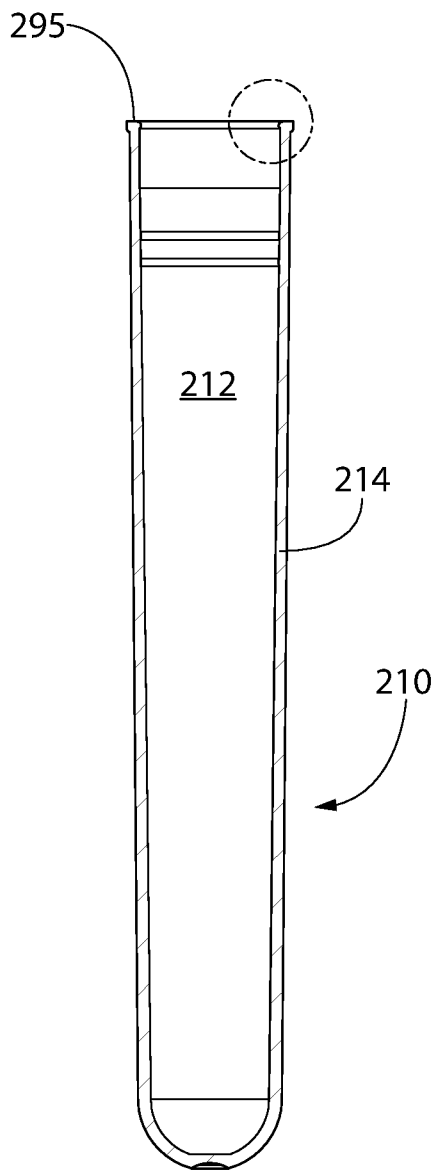

FIG. 5

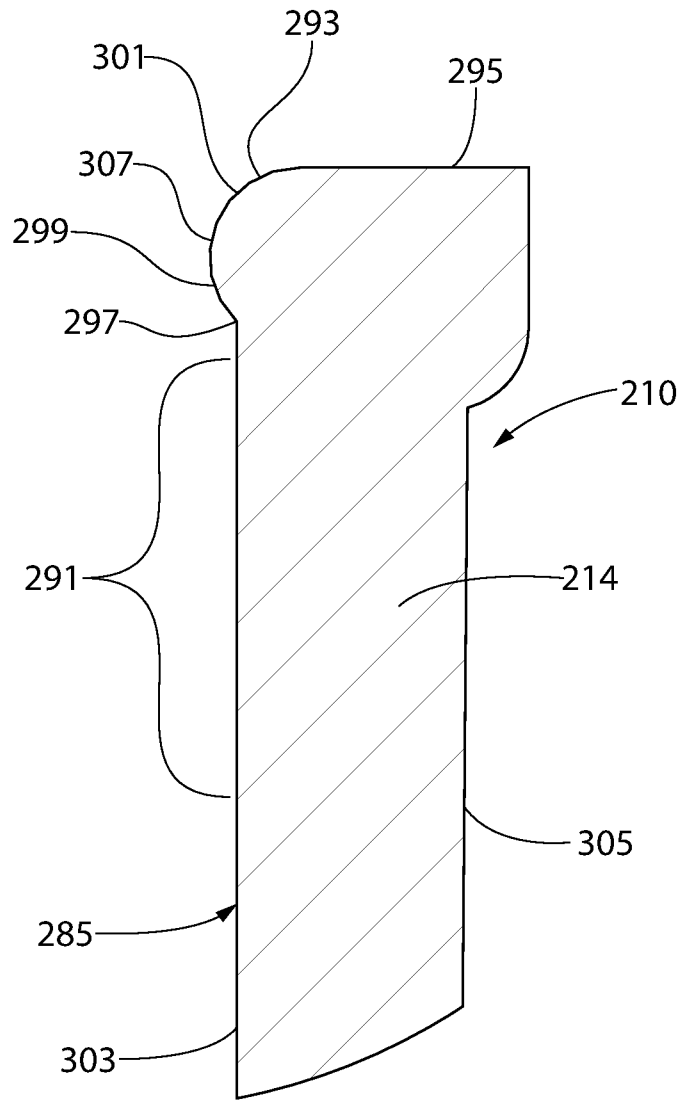

FIG. 6

5/5

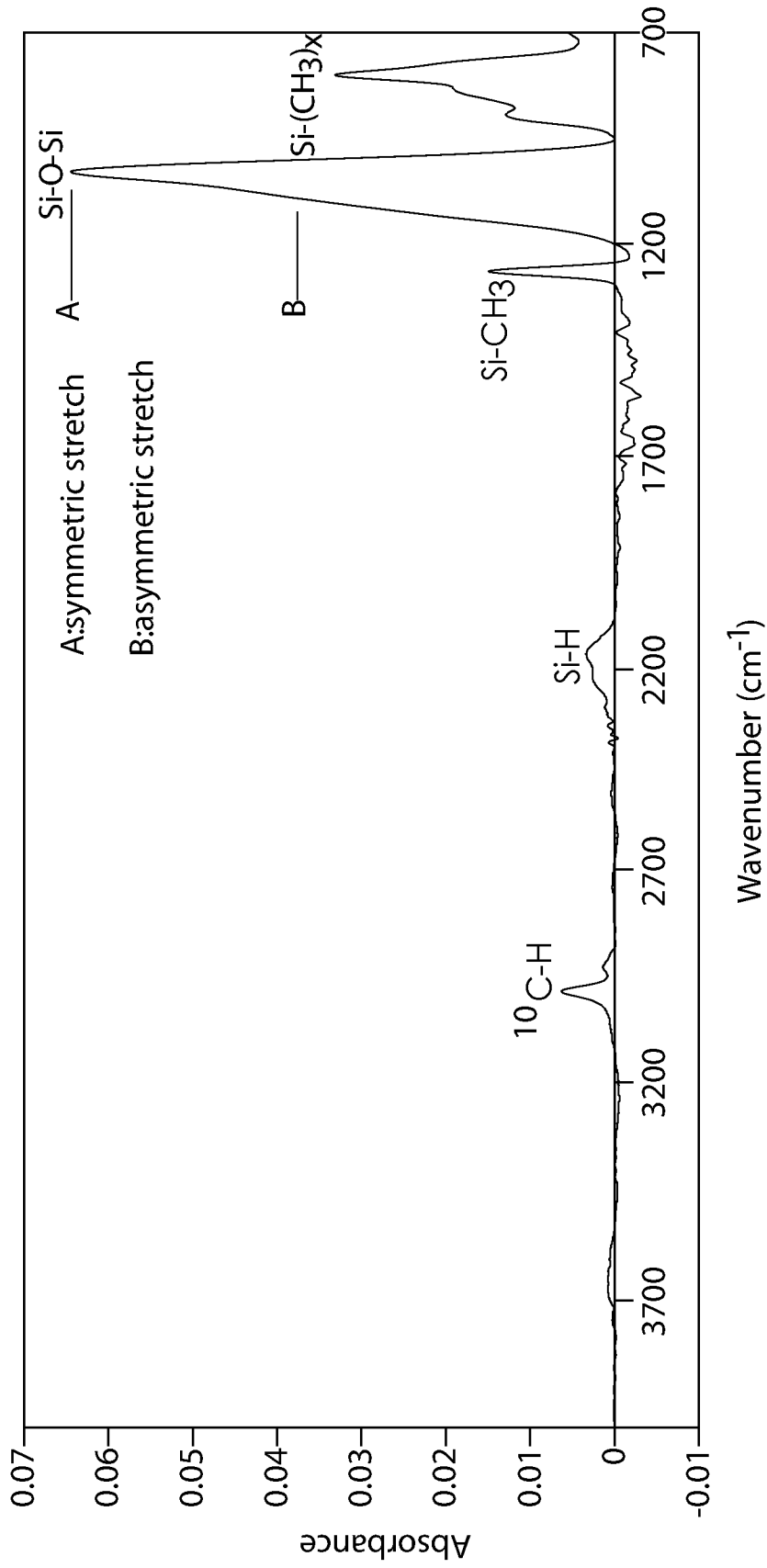

FIG. 7

