

Jan. 16, 1951

R. H. RUZSICKA  
EGG WASHING MACHINE

2,538,331

Filed Aug. 13, 1947

3 Sheets-Sheet 1

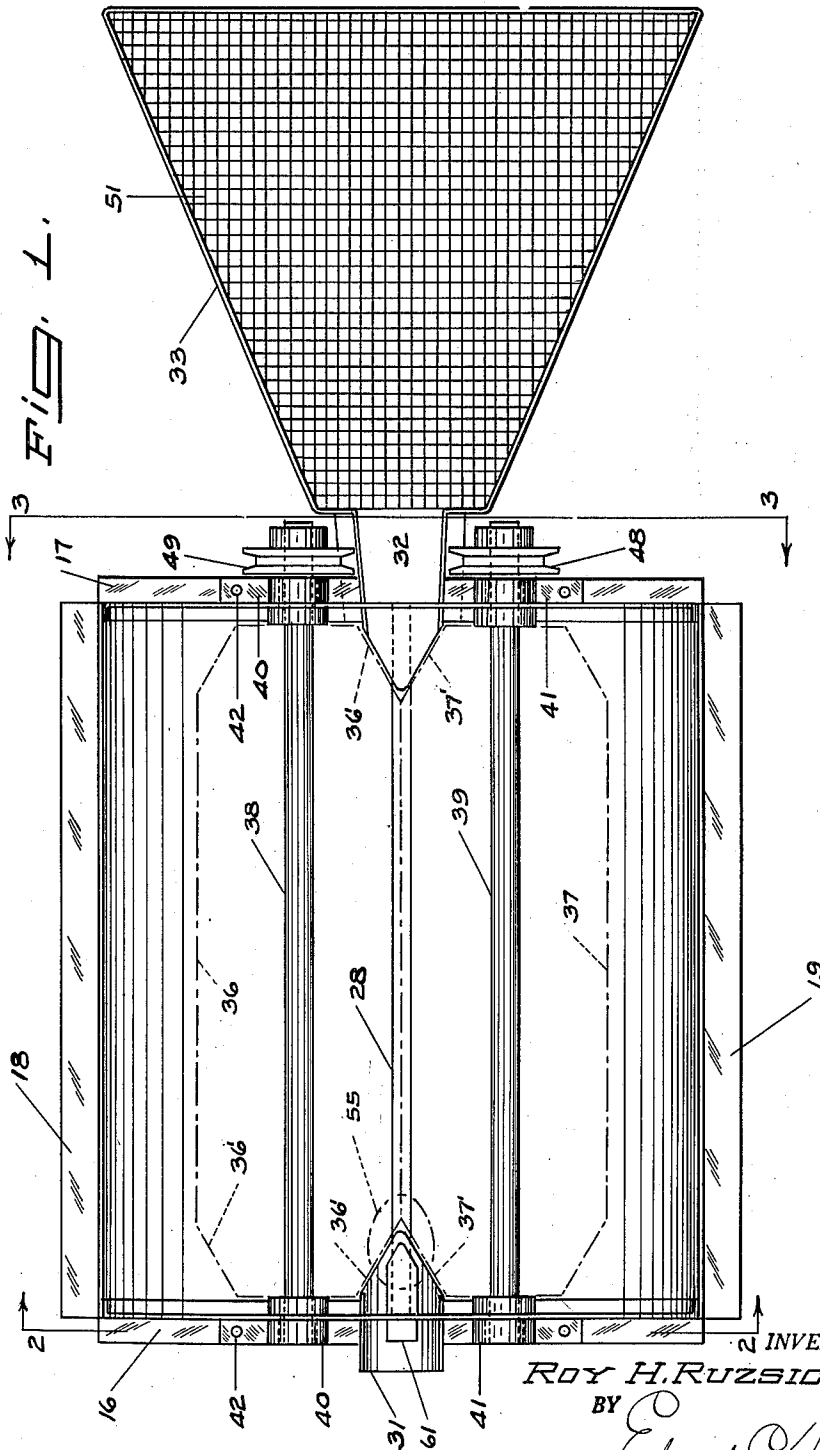

FIG. 1.

INVENTOR.  
ROY H. RUZSICKA  
BY *Edward Healy*  
ATTORNEY

Jan. 16, 1951

R. H. RUZSICKA  
EGG WASHING MACHINE

2,538,331

Filed Aug. 13, 1947

3 Sheets-Sheet 2

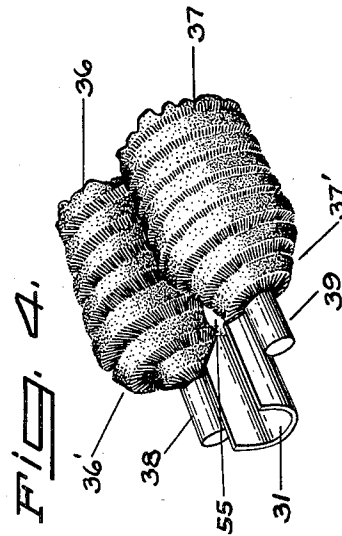
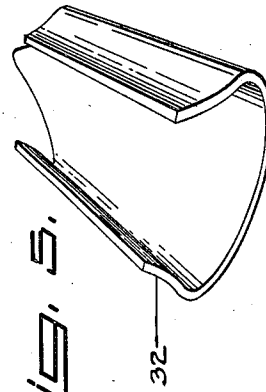
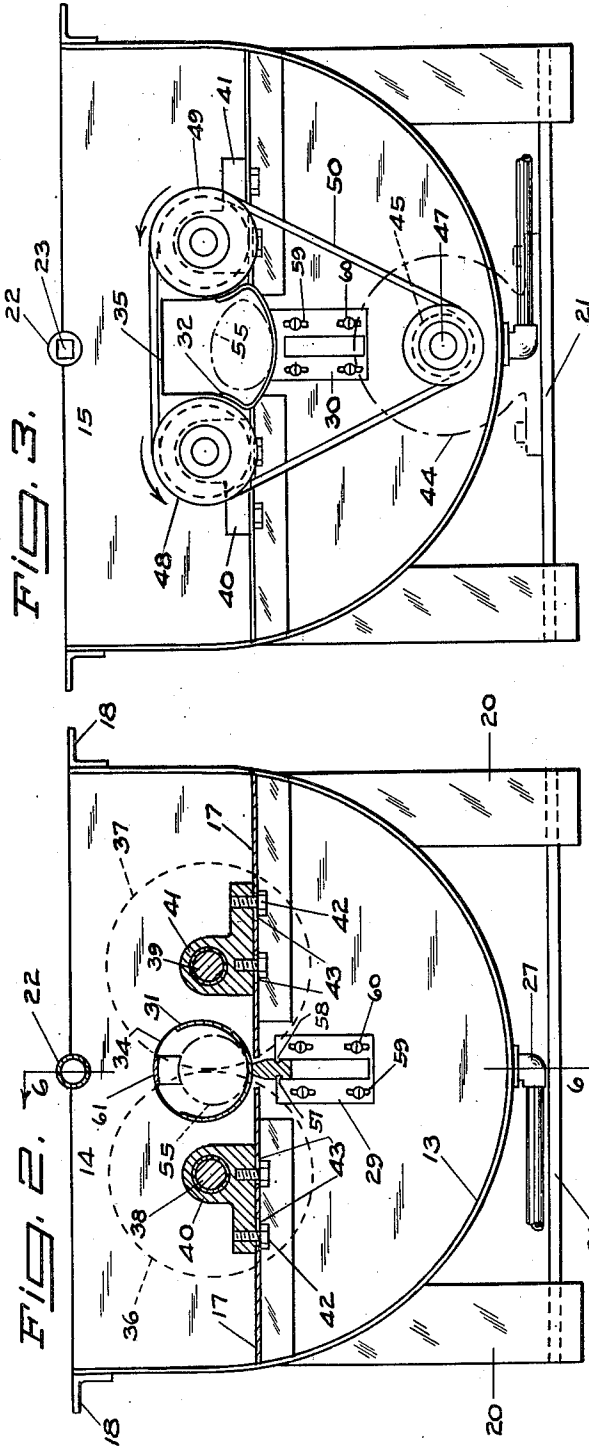

INVENTOR.  
**ROY H. RUZSICKA**  
BY *Edward Healy*  
ATTORNEY

Jan. 16, 1951

R. H. RUZSICKA  
EGG WASHING MACHINE

2,538,331

Filed Aug. 13, 1947

3 Sheets-Sheet 3

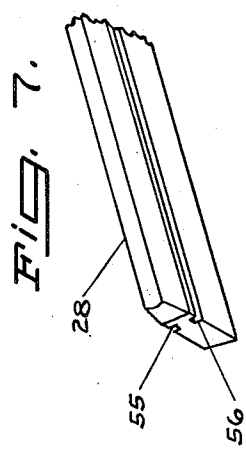
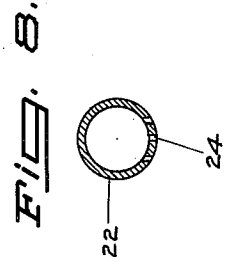
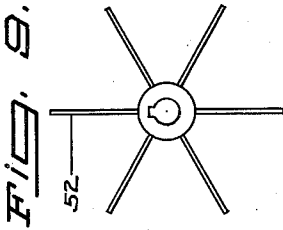
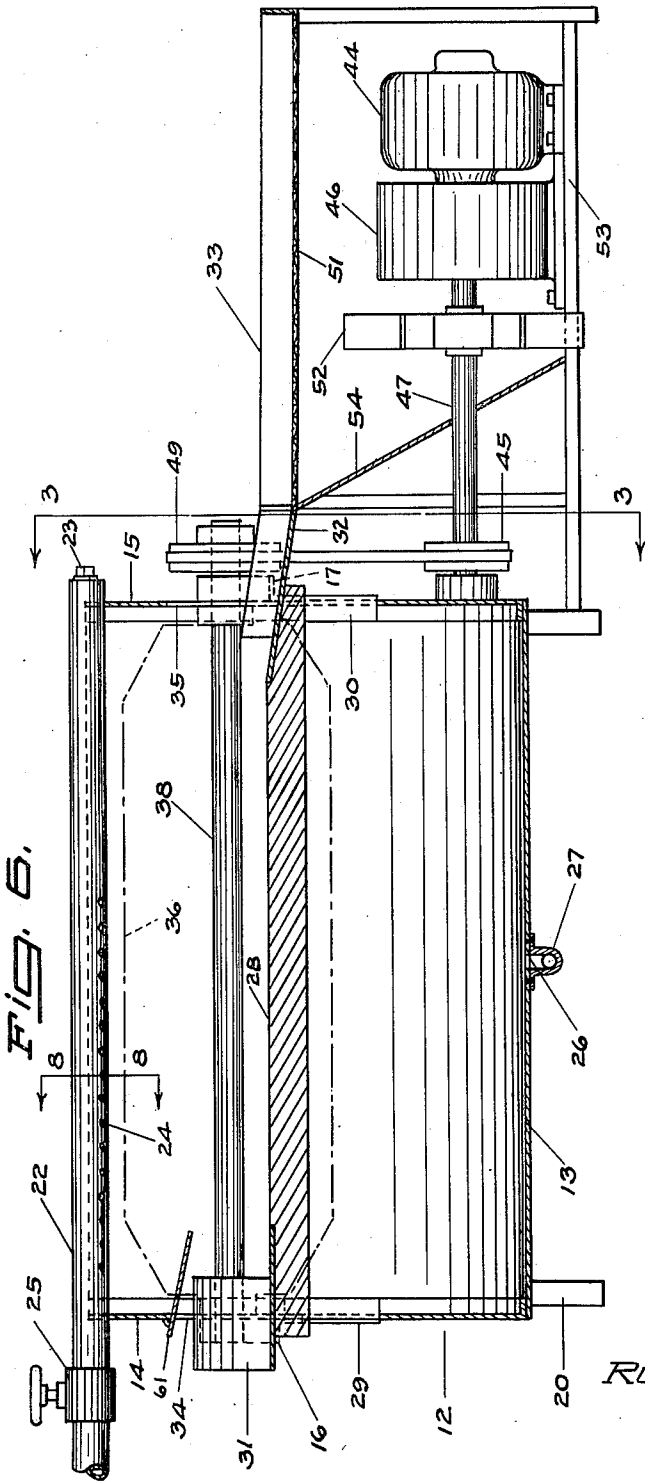

INVENTOR.  
**ROY H. RUZSICKA**  
BY *Edward Healy*  
ATTORNEY

# UNITED STATES PATENT OFFICE

2,538,331

## EGG WASHING MACHINE

Roy H. Kuzsieska, Petaluma, Calif.

Application August 13, 1947, Serial No. 768,432

### 2. Claims. (Cl. 15—3.14)

1

This invention relates to an improved egg washing machine and has particular reference to a specially constructed device for cleansing the shells of eggs before they are sold to the public. The invention also relates to a device that can be utilized for oiling, polishing and disinfecting eggs and washing certain kinds of fruits and nuts and other types of circular or semi-circular articles.

One of the objects of the present invention is the provision, in the machine, of a pair of elongated circular, revolving brushes arranged in parallelism with a continuous stream of water supplied thereto, whereby eggs inserted between the said brushes are automatically washed as they are conveyed through the machine.

Another object of the present invention is the provision of a specially constructed track for conveying the eggs through the machine and to provide spirally shaped brushes revolved in the same direction, whereby a floating action is produced on the eggs as they are conveyed through the machine.

A further object of the present invention is the provision of a specially formed guide for guiding the eggs between the revolving brushes and a second guide for guiding the eggs from the brushes.

A still further object of the present invention is the provision of an overhead water system for providing water to wash the eggs and to supply the said water to only a portion of the brushes, whereby the said brushes are utilized for both washing and wiping the eggs.

A still further object of the present invention is the provision of means for automatically drying the eggs.

Other objects and advantages will be apparent during the course of the following description.

In the accompanying drawings forming a part of the specification, wherein for the purpose of illustration, like numerals designate like parts throughout the same,

Fig. 1 is a top plan view of the machine, for the purpose of clarity, the water supply pipe being removed and the revolving brushes illustrated in dot and dash lines.

Fig. 2 is a front end sectional view of the device taken on line 2—2 of Fig. 1, looking in direction of the arrows.

Fig. 3 is a rear end sectional view of the device taken on line 3—3 of Fig. 1, looking in direction of the arrows.

Fig. 4 is a perspective view of the front end

2

portion of the revolving brushes and also showing an egg between the brushes.

Fig. 5 is a perspective view of the guide for conveying the eggs to the dryer.

Fig. 6 is a central vertical sectional view of the machine taken on line 6—6 of Fig. 1, looking in direction of the arrows.

Fig. 7 is a perspective fragmentary view of the track provided for conveying the eggs through the machine.

Fig. 8 is an enlarged vertical sectional view of the water supply pipe, taken on line 8—8 of Fig. 6, and

Fig. 9 is an end elevational view of a fan employed for thoroughly drying the eggs.

Referring in detail to the drawings and the numerals thereof, the numeral 12 designates as a whole, a suitable housing, which housing is open at the top and is preferably made of sheet metal, but can be made of any suitable material, and is formed circular at the lower portion thereof as at 13 and provided with upwardly extending vantage in Figs. 2 and 6. An angle number 14 is fixed across the front end portion 14 of the housing and likewise a second angle 17 is fixed across the rear portion 15. Reinforcing angles 18 and 19 are fixed along the upper extremities of the sides as shown in Figs. 1 and 2. The numeral 20 designates suitable legs for supporting the housing and the numeral 21 braces for reinforcing the same. A water supply pipe 22, plugged at the outer end thereof as at 23 and provided with a plurality of discharge openings 24, is longitudinally positioned over the top of the housing as shown in Fig. 6. A valve 25 controls the flow of the fluid. A drain outlet 26 is provided in the bottom of the housing and a pipe 27 conveys the fluid to a suitable remote location.

The eggs are conveyed through the machine on a specially constructed track 28, which track is mounted in the housing directly beneath the water supply pipe 22 and is positioned in parallelism therewith. The said track longitudinally extends through the housing and is secured to suitable supports 29 and 30 that are fixed to the end walls of the housing 14 and 15, respectively. A specially shaped guide 31 extends through the front housing wall 14 for guiding the eggs on the said track and a second guide 32 extends from the rear housing wall 15 for guiding the eggs from the track to the tray 33. Suitable openings 34 and 35, are provided through the housing end walls 14 and 15 for accommodating the said guides. The means provided for moving the eggs

along the track and cleansing the said eggs, consists in the providing of a pair of revolving spirally coiled cylindrical brushes, 35 and 37, and mounting the said brushes on suitable shafts 38 and 39, respectively, which shafts are revolvably supported in suitable bearings, 40 and 41, respectively, which are fixed in the end walls of the housing. The said spirally coiled brushes are positioned straddle the track 28 and in parallelism one with the other as shown to advantage in Figs. 1, 2 and 4, whereby the eggs are caused to be moved along the track and thoroughly cleansed during the revolvable movement of the brushes. The outer end portions of the said brushes are preferably tapered as indicated at 35 and 37 to facilitate the admitting and releasing of the eggs to and from the track 28. The said bearings 40 and 41 are retained in adjustable position by the cap screws 42 extending through the slots 43, whereby the distance between the brushes can be varied in case of wear.

The means provided for imparting revolvable movement to the brushes comprises a motor 44 connected to the said brushes in any suitable manner. The speed of the drive pulley 45 is reduced in any suitable manner to cause the brushes to revolve at the desired speed. The numeral 46 designates a housing enclosing a conventional reduction gear mechanism for reducing the speed of the drive shaft 47. Numerals 48 and 49 designate V-shaped pulleys fixed on the outer end portions of the brush shafts 38 and 39, respectively, for accommodating a V-belt 50, as shown to advantage in Figs. 3 and 6. A suitable fan 52 is fixed on the said drive shaft 47 for blowing air through the bottom 51, of the tray 33, which bottom is preferably formed of a wire screen as illustrated in Figs. 1 and 6. The said motor and fan are supported on a suitable frame 53. A baffle plate 54 is preferably provided for deflecting air to the tray. The dryer fan 52 can be positioned in any desired location to properly dry the eggs in the most efficient manner. For example, the said fan can be positioned between the gear reduction mechanism in the housing 46 and the motor 44, or the motor can be moved closer to the housing frame and the shaft of the motor extended and the fan positioned on the opposite end of the motor. This entire unit can be placed beneath the cleaner instead of below the dryer if desired.

The side portions of the track 28 are grooved as indicated at 55 and 56 in Fig. 7 which grooves fit slidably on horizontal flange portions 57 and 58 provided on the track supporting members as shown to advantage in Fig. 2. The vertical flange portions of the track supporting members 29 and 30 are formed with vertically elongated holes 59 for receiving suitable bolts or screws 60, whereby the said supporting members 29 and 30 and track thereon are vertically adjustable. This adjustable feature enables the center of the egg or other object placed on the track to always be slightly below the center of the brush axis, thereby giving a slight downward thrust to the egg being cleaned on the track and thus preventing the egg from coming out on top.

It will be seen to advantage in Fig. 3 that the brush members are revolved in the same direction and also to advantage in Fig. 4 that both of the brushes are spirally coiled in the same direction. The egg or other object placed on the track between the brushes is thus pushed downwardly on one side by one brush and lifted upwardly on the

opposite side by the other brush and at the same time conveyed longitudinally along the track. The egg is thus automatically revolved many times causing the entire surface thereof to come into contact with the revolving brushes in its course of travel through the machine. The brushes also keep the eggs aligned, enabling the eggs to travel straight throughout the entire length of the machine regardless of which end of the egg is inserted, thereby preventing the egg from turning end over end which would cause breakage and disturbance of the air cell. All sizes of eggs are readily cleaned. The brushes are self-cleaning, as centrifugal force removes any dirt or foreign substance from the brushes that have been removed from the eggs. An elongated resilient finger 61 extends through the opening 34 in the housing end member 14 and is secured to said member to lightly press the eggs downwardly on the track when starting the eggs through the brushes. Although the said brushes are spiraled in the same direction, the spirals can run in opposite directions if desired.

From the foregoing description taken in conjunction with the accompanying drawings, it will be obvious that when an egg is placed on the front guide 31 and is caught between the tapered end portions 36' and 37' of the revolving brushes as shown in Figs. 1 and 2, the spirally coiled brushes will push the egg along the track 28 to the outlet guide 32. During the movement of the eggs along the said track, water from the overhead pipe 22 will fall through the opening 24 to the eggs, whereby the revolving brushes will thoroughly cleanse the eggs. It will be noted that the said pipe is apertured for only a part of its full length, whereby the flow of water is stopped a short distance from the outlet guide 32, enabling the revolving brushes to wipe the eggs before they are released to the tray 33, where they are thoroughly dried by air blown from the fan 55 through the screened bottom of the tray. The eggs will automatically turn and roll through the said outlet guide 32 as shown to advantage in Fig. 2.

It is to be understood that the form of my invention herewith shown and described is to be taken as a preferred example of the same and that various changes relative to the material, size, shape and arrangement of parts may be resorted to without departing from the spirit of the invention or the scope of the subjoined claims.

Having thus described my invention, I claim:

1. A device of the character described for washing eggs and the like, comprising a frame, a pair of elongated circular brush members revolvably supported thereon and arranged in parallelism and in proximity to each other, a track removably supported on the frame and positioned between the brush members and below the centers thereof for carrying the eggs, the said track being vertically adjustable for enabling eggs of different sizes to be carried in the correct height with respect to the centers of the brush members, means for guiding the eggs to the track, an apertured water supply pipe positioned above the track and in parallelism therewith for enabling water to fall on the eggs and brush members, the said brush members being formed with spirally coiled brushes that are spiraled in the same direction and means for revolving the brushes in the same direction, whereby the eggs are revolved transversely on the track and moved longitudinally along the track simultaneously.

2. A device of the character described for wash-

5

ing eggs and the like, comprising a frame, a pair of elongated circular brushes revolvably supported thereon and arranged in parallelism and in proximity with each other, means for revolving the brushes, said brushes being revolved in the same direction, whereby the eggs are revolved, an elongated stationary track positioned between the brushes and below the horizontal centers thereof for carrying the eggs, means for guiding the eggs to the front end portions of the brushes, said front end portions of the brushes being tapered for receiving the eggs, the said brushes being spirally coiled in the same direction, whereby the eggs are moved along the stationary track, an apertured water supply pipe positioned above the track and in alignment therewith for providing water on the eggs and causing the eggs to be washed during their move-

6

ment along the track, a tray positioned at the rear end portion of the track for receiving the washed eggs and a fan revolved with the brushes for drying the washed eggs in the tray.

ROY H. RUZSICKA.

REFERENCES CITED

The following references are of record in the file of this patent:

UNITED STATES PATENTS

Number	Name	Date
105,891	Blake -----	Aug. 2, 1870
528,195	Warr -----	Oct. 30, 1894
616,284	Baker et al. -----	Dec. 20, 1898
1,055,121	Becker -----	Mar. 4, 1913
2,357,892	Grant -----	Sept. 12, 1944