



(12) EUROPEAN PATENT APPLICATION

(43) Date of publication:
29.11.2006 Bulletin 2006/48

(51) Int Cl.:
F25D 21/08 (2006.01)

(21) Application number: 05425467.7

(22) Date of filing: 30.06.2005

(84) Designated Contracting States:
AT BE BG CH CY CZ DE DK EE ES FI FR GB GR
HU IE IS IT LI LT LU MC NL PL PT RO SE SI SK TR
Designated Extension States:
AL BA HR LV MK YU

(72) Inventor: Floris, Giuseppe
09096 S.Giusta OR (IT)

(74) Representative: Vinci, Marcello
Ufficio Veneto Brevetti
Via Sorio 116
35141 Padova (IT)

(30) Priority: 27.05.2005 IT PD20050160

(71) Applicant: Floris, Giuseppe
09096 S.Giusta OR (IT)

(54) Anti-freeze protection device for chillers

(57) The invention is a new anti-freeze protection device for chillers, comprising an electric/electronic control circuit (3) connected to ice sensors (1) and local heaters (2). The sensors (1) and heaters (2) are applied and positioned in the areas where ice is most likely to form and/or in which ice causes the greatest reduction in chiller efficiency. In the event of formation of ice, the sensors indi-

cate its presence to the electric/electronic circuit (3) which suspends operation of the chiller, adjusts opening and closing of the expansion valves (4) located at the evaporator inlet, or suspends operation of the chiller compressor only, and if necessary operates the heaters (2), thus melting the ice into water which is removed by the known means (C) used for removing condensate.

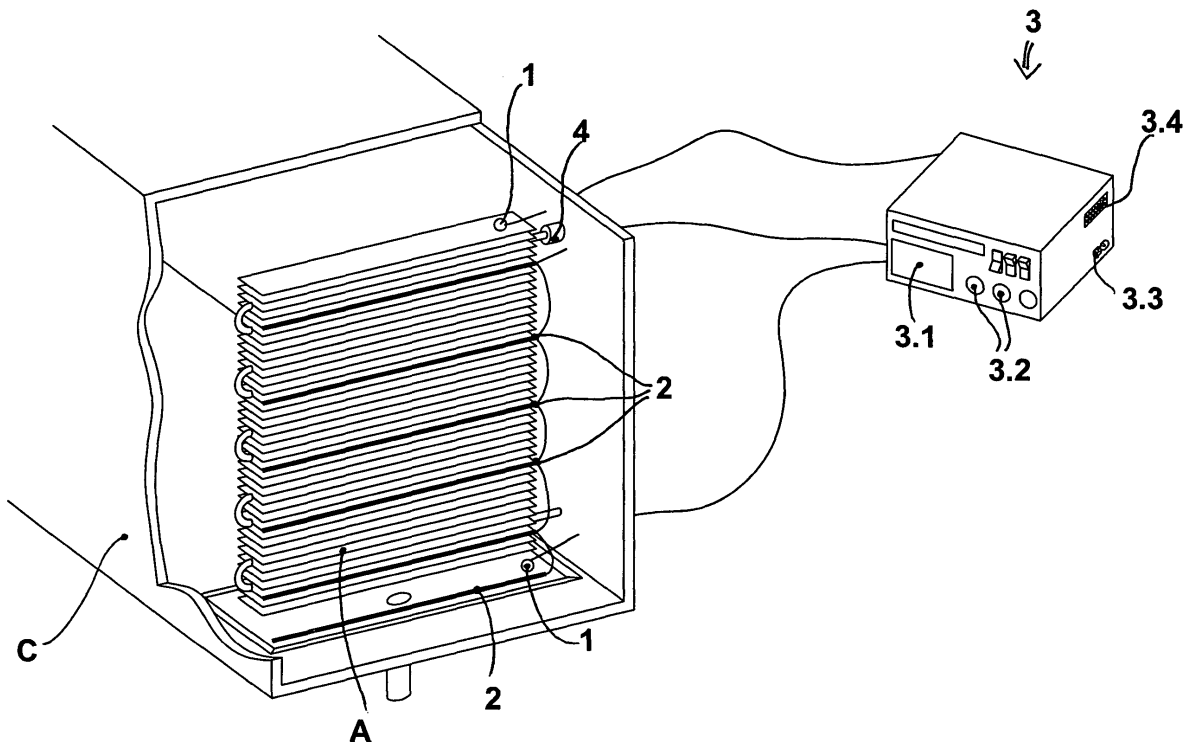

Fig.1

Description

[0001] The present patent concerns the chillers of conditioners, refrigerated display units and industrial cooling systems and in particular it concerns a device for control, prevention and removal of any ice that may have formed on the ducts and on the finned packs of the chillers.

[0002] It is known that cooling systems use a gas or mixture of gas or a previously cooled non-freezable liquid which is circulated in a closed cooling circuit in which said gas is compressed and expanded.

[0003] Exploiting the drop in temperature due to expansion of the gas and the increase in temperature due to compression of the same gas, the temperature of an environment, for example the external environment, is increased by heat exchange, and the temperature of another environment, for example the environment to be cooled, is lowered via heat exchange.

[0004] At the level of the expansion and compression ducts, i.e. cooling and heating ducts, of the cooling circuit, plates are applied between which the air is circulated to cool the closed environment of the chiller by heat exchange or to disperse the heat produced, i.e. removed from the environment to be cooled.

[0005] The set of compression or expansion ducts and plates is commonly called finned pack.

[0006] It is known that the humidity contained in the air condenses and is deposited on the plates of the finned packs. Normally said condensed water drops into a tray provided for the purpose, or drip pan, from which it is removed and drained.

[0007] When the physical conditions, for example the temperature on the finned pack or the velocity of the cooling air, are beyond certain limits, the condensation water freezes on the plates and on the ducts of the finned cooling pack (evaporator).

[0008] When the temperature drops below zero, the drip pans have to be heated so that the condensed water flows out normally without re-freezing in the drip pans themselves or in the drain channels.

[0009] Said ice produces various highly negative effects on the efficiency of the chiller.

[0010] A first negative effect is due to the lower thermal conduction of the layer of ice. The heat of the air passing through the finned pack is not absorbed, or is absorbed to a lesser extent, by the gas circulating in the ducts of the finned pack and consequently there is less cooling of the air passing through the finned pack.

[0011] The chiller consequently increases its speed to reach the set cooling temperature. In this way the cooling unit compressor is overloaded and subject to extra work without a consequent significant improvement in result.

[0012] A second negative effect consists in reduction of the gap in the finned pack. The ice that forms on the plates and on the ducts increases the overall dimensions of the plates and ducts and consequently the space for passage of the air, or the gap, decreases, reducing the cooling flow rate and capacity with the result that the air

circulation fan is overloaded.

[0013] To remedy all the above drawbacks a new anti-freeze protection device for chillers has been designed and implemented.

[0014] The aim of the new device is to detect and eliminate ice from the areas where it is most likely to form.

[0015] A further aim of the new device is to eliminate ice before its formation significantly reduces the efficiency of the chiller.

[0016] These and further aims, direct and complementary, are achieved by the new anti-freeze protection device for chillers comprising an electric/electronic control circuit, ice sensors and local heaters.

[0017] The sensors and heaters are applied and positioned, spaced from each other if necessary, in the points and areas where formation of ice is most likely and/or where ice causes the greatest reduction in chiller efficiency.

[0018] Said sensors and said heaters are connected to the electric/electronic control circuit.

[0019] In the event of formation of ice, the sensors signal its presence to the electric/electronic circuit which suspends operation of the chiller, closing the expansion valves located at the evaporator inlet or regulating opening of said valves and consequently the amount of refrigerant in circulation or the expansion temperature, or suspends operation of the chiller compressor only, and if necessary operates the heaters in order to melt the ice into water which is removed using the means known for removal of condensation.

[0020] The sensors can be provided with a regulator, in order to increase or decrease their sensitivity.

[0021] Said electric/electronic circuit can be provided with controls and adjusting means in order to allow the setting of various operating functions such as activation-deactivation times, switch-off of the chiller unit and timing of switch-on of the heaters, switch-off of the chiller unit and joint operation of the heaters, activation when ice is detected or timed activation, and others.

[0022] Anti-freeze protection device for chillers, comprising one or more ice sensors, one or more heaters, at least one electric/electronic circuit connected to said sensors and heaters, and in which said sensors and heaters are located at the points where ice is most likely to form.

Said electric/electronic circuit activates said heaters when said sensors detect the formation of ice.

[0023] The characteristics of the new anti-freeze protection device for chillers will be highlighted in greater detail in the following description with reference to the drawing, attached as a non-limiting example.

[0024] The figure illustrates an example of embodiment and application of the new device.

[0025] In this example the ice sensors (1) detect the formation of ice on a finned pack (A) and in the condensate collection tray inside a duct (C) of a cooling system.

[0026] Electric heaters (2) are positioned on some plates of the finned pack (A) and in the condensate collection tray.

[0027] Both the sensors (1) and the heaters (2) are connected to the electric/electronic circuit (3).

[0028] The finned pack inlet duct is provided with regulator valve (4) connected to said electric/electronic circuit (3).

[0029] Said electric/electronic circuit (3) is provided with at least one display (3.1) to show the parameters detected and the operating parameters, with buttons and knobs (3.2) for adjustment of the operating parameters and a connector (3.3) for the supply.

[0030] A connector (3.4) can be provided for interfacing to a computer in order to permit detection and optimised remote setting of the electric/electronic circuit.

[0031] The new device constituted as described above detects the formation of ice at the critical points and/or at the points where formation of ice is most likely.

[0032] If the formation of ice is detected by the sensors (1), the electric/electronic circuit (3) performs the set actions to melt or remove it.

[0033] One possible action provides for closure of the refrigerant inlet valves or cocks (4) or suspension of operation of the chiller unit, and therefore interruption of the flow of refrigerant into the ducts of the finned pack (A). The electric fan continues to operate and the air flow melts the ice without significantly increasing the air temperature.

[0034] A second possible action provides for stoppage of the inlet of refrigerant or of the chiller unit and electric fan and subsequent operation of the heaters (2).

[0035] The ice is melted into water which is removed like the usual condensate.

[0036] Once the ice has been melted, the heaters (3) are switched off and the chiller unit and electric fan are re-activated.

[0037] The new device can also be connected to humidity detection probes and to humidifiers and used to keep a constant humidity level in the cooling system air.

[0038] Therefore, with reference to the preceding description and the attached drawing, the following claims are expressed.

Claims

1. Anti-freeze protection device for chillers, **characterised in that** it comprises one or more ice sensors (1), one or more heaters (2), at least one electric/electronic circuit (3) connected to said sensors (1) and heaters (3), and wherein said sensors (1) are located at the points where ice is most likely to form.
2. Anti-freeze protection device for chillers according to claim 1, **characterised in that** said heaters (2) are located at the points where ice is most likely to form.
3. Anti-freeze protection device for chillers according to claims 1, 2, **characterised in that** it is provided

with electromechanical valves (4) for regulating the flow of refrigerant gas to the finned pack (A), and wherein said electromechanical valves are connected to said electric/electronic circuit (2).

5

4. Anti-freeze protection device for chillers according to claims 1, 2, **characterised in that** said electric/electronic circuit (3) operates said heaters (3) and/or regulates the opening of said solenoid valves (4) when said sensors (1) detect the formation of ice.

10

5. Anti-freeze protection device for chillers according to claims 1, 2, **characterised in that** said electric/electronic circuit (3) operates said heaters (3) and/or regulates the opening of said solenoid valves (4) at pre-set intervals.

15

6. Anti-freeze protection device for chillers according to the preceding claims, **characterised in that** said electric/electronic circuit is provided with a display (3.1) for showing the parameters detected and the operating parameters, and with buttons and knobs (3.2) for adjustment of the operating parameters.

20

7. Anti-freeze protection device for chillers according to the preceding claims, **characterised in that** it interrupts operation of the chiller cooling unit before operating the heaters (2).

25

8. Anti-freeze protection device for chillers according to the preceding claims, **characterised in that** it interrupts operation of the cooling unit and of the electric fan before operating the heaters (3).

30

9. Anti-freeze protection device for chillers according to the preceding claims, **characterised in that** said electric/electronic circuit (3) is provided with a connector (3.4) for interfacing to a computer, thus permitting detection and optimised remote setting of the electric/electronic circuit operating parameters.

35

40

10. Anti-freeze protection device for chillers according to the preceding claims, **characterised in that** it is connected to humidity sensors and to humidifying devices positioned in the cooling system ventilation duct, in such a way as to maintain a constant humidity level.

45

50

55

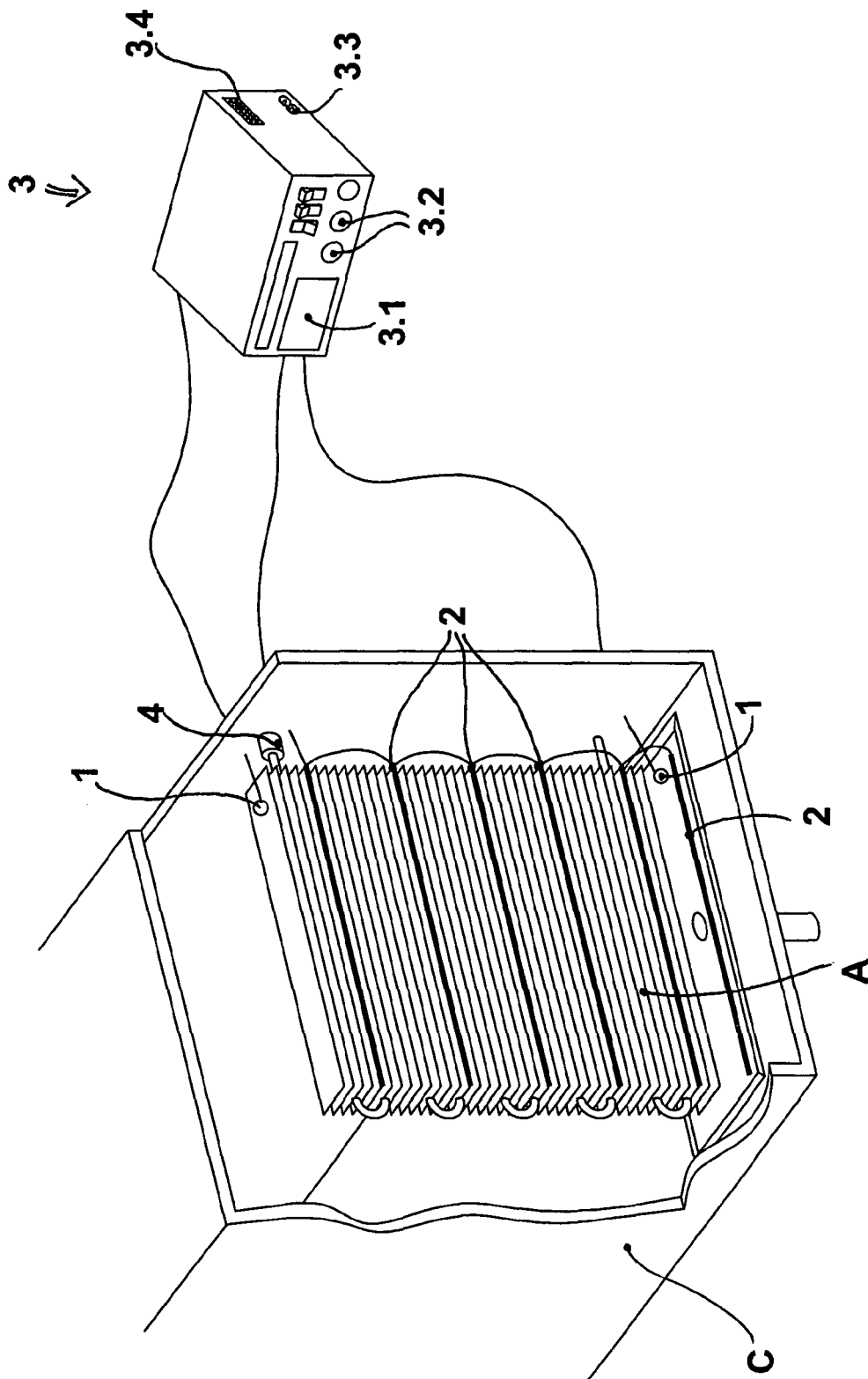

Fig.1



DOCUMENTS CONSIDERED TO BE RELEVANT			
Category	Citation of document with indication, where appropriate, of relevant passages	Relevant to claim	CLASSIFICATION OF THE APPLICATION (IPC)
X	US 4 265 092 A (ABRAHAM ET AL) 5 May 1981 (1981-05-05)	1,2,7	INV. F25D21/08
Y	* column 4, lines 18-20 *	3-6,8-10	
Y	* column 4, lines 31-36 *		
Y	* column 6, lines 17-68; figures 1,3 *	10	
Y	----- US 2001/047657 A1 (CHO SUNG-HO ET AL) 6 December 2001 (2001-12-06)	3-5	
Y	* paragraphs [0035] - [0043]; figures 1-4 *		
Y	----- US 5 842 355 A (KALIS ET AL) 1 December 1998 (1998-12-01)	8	
Y	----- EP 0 819 898 A (THERMOVONICS CO., LTD) 21 January 1998 (1998-01-21)	6,9,10	
Y	* page 13, lines 9-51; claims 19-26; figures 31-34 *		
X	----- EP 0 787 961 A (WHIRLPOOL EUROPE B.V) 6 August 1997 (1997-08-06)	1,2	TECHNICAL FIELDS SEARCHED (IPC)
X	* the whole document *		F25D
X	----- US 6 467 282 B1 (FRENCH PATRICK D ET AL) 22 October 2002 (2002-10-22)	1	
A	* column 7, lines 37-62; figures 1,2,9,11 *		
A	* column 12, lines 3-24 *		
A	* column 17, line 12 - column 19, line 3 *		
A	----- US 4 979 431 A (FUJIMOTO ET AL) 25 December 1990 (1990-12-25)	1-5,7-10	
A	* column 6, lines 42-66; figures 1,7 *		
	----- -/--		
The present search report has been drawn up for all claims			
Place of search The Hague		Date of completion of the search 16 August 2006	Examiner Léandre, A
CATEGORY OF CITED DOCUMENTS X : particularly relevant if taken alone Y : particularly relevant if combined with another document of the same category A : technological background O : non-written disclosure P : intermediate document		T : theory or principle underlying the invention E : earlier patent document, but published on, or after the filing date D : document cited in the application L : document cited for other reasons ----- & : member of the same patent family, corresponding document	

EPO FORM 1503 03.92 (P04C01)



DOCUMENTS CONSIDERED TO BE RELEVANT			
Category	Citation of document with indication, where appropriate, of relevant passages	Relevant to claim	CLASSIFICATION OF THE APPLICATION (IPC)
A	US 4 084 388 A (NELSON ET AL) 18 April 1978 (1978-04-18) * column 1, line 56 - column 2, line 31; figure 1 * * column 3, line 8 - column 4, line 5 * -----	1-5	
A	US 6 318 095 B1 (GUO CHARLES Z ET AL) 20 November 2001 (2001-11-20) * figures 1,2a,2b,2c * -----	1-5	
A	EP 0 603 576 A (WHIRLPOOL EUROPE B.V; WHIRLPOOL EUROP) 29 June 1994 (1994-06-29) * the whole document * -----		
A	US 2002/184900 A1 (WELLMAN KEITH E) 12 December 2002 (2002-12-12) * figure 8 * -----		
The present search report has been drawn up for all claims			TECHNICAL FIELDS SEARCHED (IPC)
Place of search The Hague		Date of completion of the search 16 August 2006	Examiner Léandre, A
CATEGORY OF CITED DOCUMENTS X : particularly relevant if taken alone Y : particularly relevant if combined with another document of the same category A : technological background O : non-written disclosure P : intermediate document		T : theory or principle underlying the invention E : earlier patent document, but published on, or after the filing date D : document cited in the application L : document cited for other reasons & : member of the same patent family, corresponding document	

2
EPO FORM 1503 03/02 (P04C01)

ANNEX TO THE EUROPEAN SEARCH REPORT
ON EUROPEAN PATENT APPLICATION NO.

EP 05 42 5467

This annex lists the patent family members relating to the patent documents cited in the above-mentioned European search report. The members are as contained in the European Patent Office EDP file on The European Patent Office is in no way liable for these particulars which are merely given for the purpose of information.

16-08-2006

Patent document cited in search report	Publication date	Patent family member(s)	Publication date
US 4265092 A	05-05-1981	AU 538987 B2	06-09-1984
		AU 6324180 A	02-07-1981
		CA 1132808 A1	05-10-1982
		DE 3042406 A1	02-07-1981
		ES 8201820 A1	01-04-1982
		FR 2472363 A1	03-07-1981
		GB 2066442 A	08-07-1981
		HU 183235 B	28-04-1984
		JP 56100278 A	12-08-1981
US 2001047657 A1	06-12-2001	CN 1325782 A	12-12-2001
		JP 3593048 B2	24-11-2004
		JP 2001336867 A	07-12-2001
US 5842355 A	01-12-1998	NONE	
EP 0819898 A	21-01-1998	AU 2867997 A	22-01-1998
		CN 1173654 A	18-02-1998
		US 6038865 A	21-03-2000
EP 0787961 A	06-08-1997	IT MI960073 U1	30-07-1997
US 6467282 B1	22-10-2002	NONE	
US 4979431 A	25-12-1990	NONE	
US 4084388 A	18-04-1978	NONE	
US 6318095 B1	20-11-2001	NONE	
EP 0603576 A	29-06-1994	IT 227082 Y1	09-09-1997
US 2002184900 A1	12-12-2002	NONE	

EPO FORM P0459

For more details about this annex : see Official Journal of the European Patent Office, No. 12/82