

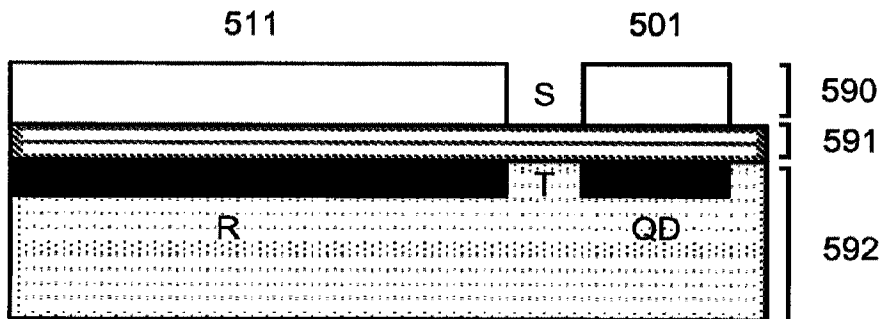

(86) Date de dépôt PCT/PCT Filing Date: 2017/06/08
 (87) Date publication PCT/PCT Publication Date: 2017/12/14
 (45) Date de délivrance/Issue Date: 2024/06/11
 (85) Entrée phase nationale/National Entry: 2018/11/29
 (86) N° demande PCT/PCT Application No.: CA 2017/050696
 (87) N° publication PCT/PCT Publication No.: 2017/210790
 (30) Priorité/Priority: 2016/06/08 (US62/347,346)

(51) Cl.Int./Int.Cl. *G06N 10/40* (2022.01),
H01L 29/66 (2006.01)
 (72) Inventeurs/Inventors:
 PIORO-LADRIERE, MICHEL, CA;
 ROCHETTE, SOPHIE, CA;
 KING GAMBLE, JOHN, US;
 TEN EYCK, GREGORY A, US;
 RUDOLPH, MARTIN, US;
 CARROLL, MALCOLM, US
 (73) Propriétaires/Owners:
 SOCPRA SCIENCES ET GENIE S.E.C., CA;
 NATIONAL TECHNOLOGY & ENGINEERING
 SOLUTIONS OF SANDIA, LLC., US
 (74) Agent: ANGLEHART ET AL.

(54) Titre : CIRCUIT ELECTRONIQUE POUR LA COMMANDE OU LE COUPLAGE DE CHARGES OU DE SPINS
 SIMPLES ET PROCEDES ASSOCIES
 (54) Title: ELECTRONIC CIRCUIT FOR CONTROL OR COUPLING OF SINGLE CHARGES OR SPINS AND METHODS
 THEREFOR



(57) **Abrégé/Abstract:**

A quantum dot structure having a split-gate geometry is provided. The quantum dot is configured for incorporation into a quantum dot array of a quantum processing unit. A gap between a reservoir accumulation gate and a quantum dot accumulation gate provides a tunnel barrier between an electric charge reservoir and a quantum dot well. An electrical potential applied to the gates defines a tunnel barrier height, width and charge tunneling rate between the well and the reservoir without relying on any barrier gate to control the charge tunneling rate.

(12) INTERNATIONAL APPLICATION PUBLISHED UNDER THE PATENT COOPERATION TREATY (PCT)

(19) World Intellectual Property
Organization
International Bureau(10) International Publication Number
WO 2017/210790 A1(43) International Publication Date
14 December 2017 (14.12.2017)

(51) International Patent Classification:

H01L 39/02 (2006.01) *H01L 39/24* (2006.01)
G06N 99/00 (2010.01)

(21) International Application Number:

PCT/CA2017/050696

(22) International Filing Date:

08 June 2017 (08.06.2017)

(25) Filing Language:

English

(26) Publication Language:

English

(30) Priority Data:

62/347,346 08 June 2016 (08.06.2016) US

(71) Applicants: **SOCPRA SCIENCES ET GÉNIE S.E.C.** [CA/CA]; Pavillon Irénée-Pinard, B6-3012, 2500, boul. de l'Université, Sherbrooke, Québec J1K 2R1 (CA). **NATIONAL TECHNOLOGY & ENGINEERING SOLUTIONS OF SANDIA, LLC.** [US/US]; 1515 Eubank SE, Albuquerque, New Mexico 87123 (US).(72) Inventors: **PIORO-LADRIERE, Michel**; 3050 rue André-Cailloux, Sherbrooke, Québec J1N 0G5 (CA). **ROCHETTE, Sophie**; 1411 rue Tétreault, Sherbrooke, Québec J1K 2N7 (CA). **KING GAMBLE, John**; Sandia National Laboratories, MS 1322, Albuquerque, New Mexico 87185 (US). **TEN EYCK, Gregory A**; Sandia National Laboratories, MS 156, Albuquerque, New Mexico 87185 (US). **RUDOLPH, Martin**; Sandia National Laboratories, MS 0892, Albuquerque, New Mexico 87185 (US). **CARROLL,****Malcolm**; Sandia National Laboratories, MS 0892, Albuquerque, New Mexico 87185 (US).(74) Agent: **ANGLEHART, James** et al.; Anglehart, 1939 de Maisonneuve Ouest, Montreal, Québec H3H 1K3 (CA).

(81) Designated States (unless otherwise indicated, for every kind of national protection available): AE, AG, AL, AM, AO, AT, AU, AZ, BA, BB, BG, BH, BN, BR, BW, BY, BZ, CA, CH, CL, CN, CO, CR, CU, CZ, DE, DJ, DK, DM, DO, DZ, EC, EE, EG, ES, FI, GB, GD, GE, GH, GM, GT, HN, HR, HU, ID, IL, IN, IR, IS, JP, KE, KG, KH, KN, KP, KR, KW, KZ, LA, LC, LK, LR, LS, LU, LY, MA, MD, ME, MG, MK, MN, MW, MX, MY, MZ, NA, NG, NI, NO, NZ, OM, PA, PE, PG, PH, PL, PT, QA, RO, RS, RU, RW, SA, SC, SD, SE, SG, SK, SL, SM, ST, SV, SY, TH, TJ, TM, TN, TR, TT, TZ, UA, UG, US, UZ, VC, VN, ZA, ZM, ZW.

(84) Designated States (unless otherwise indicated, for every kind of regional protection available): ARIPO (BW, GH, GM, KE, LR, LS, MW, MZ, NA, RW, SD, SL, ST, SZ, TZ, UG, ZM, ZW), Eurasian (AM, AZ, BY, KG, KZ, RU, TJ, TM), European (AL, AT, BE, BG, CH, CY, CZ, DE, DK, EE, ES, FI, FR, GB, GR, HR, HU, IE, IS, IT, LT, LU, LV, MC, MK, MT, NL, NO, PL, PT, RO, RS, SE, SI, SK, SM, TR), OAPI (BF, BJ, CF, CG, CI, CM, GA, GN, GQ, GW, KM, ML, MR, NE, SN, TD, TG).

Declarations under Rule 4.17:

— as to applicant's entitlement to apply for and be granted a patent (Rule 4.17(ii))

(54) Title: ELECTRONIC CIRCUIT FOR CONTROL OR COUPLING OF SINGLE CHARGES OR SPINS AND METHODS THEREFOR

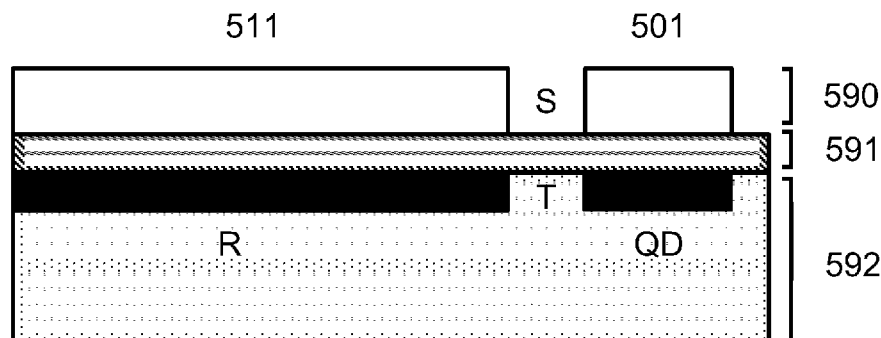
**Figure 5B**

(57) Abstract: A quantum dot structure having a split-gate geometry is provided. The quantum dot is configured for incorporation into a quantum dot array of a quantum processing unit. A gap between a reservoir accumulation gate and a quantum dot accumulation gate provides a tunnel barrier between an electric charge reservoir and a quantum dot well. An electrical potential applied to the gates defines a tunnel barrier height, width and charge tunneling rate between the well and the reservoir without relying on any barrier gate to control the charge tunneling rate.

[Continued on next page]



WO 2017/210790 A1

WO 2017/210790 A1 

Published:

- *with international search report (Art. 21(3))*
- *before the expiration of the time limit for amending the claims and to be republished in the event of receipt of amendments (Rule 48.2(h))*

ELECTRONIC CIRCUIT FOR CONTROL OR COUPLING OF SINGLE CHARGES OR SPINS AND METHODS THEREFOR

5 **[001]** This application claims priority to US provisional patent application serial number 62/347,346 filed 8 June 2016.

Technical Field

[002] This invention relates to quantum computing, and in particular to a micro-electronic circuit for control or coupling of single charges or spins, quantum computing systems incorporating the circuit and methods therefor.

10 **Background**

[003] In quantum computing, there is a need for means for controlling and coupling of single charges and spins.

15 **[004]** In accordance with one approach for the encoding and manipulation of quantum information, what is required is confinement of single electrons. The spin degree of freedom of the electron provides a natural two-level quantum system to encode the information in the form of a quantum bit (qubit), the fundamental unit of quantum information. In this case, the qubit includes a spin up state (state 0), a spin down state (state 1), and interim states that are a superposition of both the spin up and spin down states at the same time. The states of a qubit can be represented as points on the surface of a sphere (the Bloch sphere), as depicted in Figure 1.

20 **[005]** Of the variety of approaches to confining electron spins, confinement of a single electron spin in solid-state is sought with the goal of integration with solid-state (micro-) electronics. Quantum Dots (QDs) provide such confinement by using, in some implementations, electric control gates on a semiconductor substrate. Frequently used substrates include silicon (Si), aluminum gallium arsenide heterostructures (AlGaAs/GaAs), silicon germanium heterostructures
25 (Si/SiGe), and indium arsenide (InAs).

Quantum computation with spin qubits in quantum dots

[006] Quantum computation is generally represented as a sequence of operations requiring precise functionalities from a physical circuit. A typical sequence is represented in Figure 2 for a circuit constituted of single electron spin qubits with quantum dots.

[007] What is required first is an array of quantum dots (QDs) and, in some implementations, their reservoir (R), like in Figure 2a. Then each quantum dot is initialized with one electron from its reservoir, as illustrated in Figure 2b. A means for detecting the charge occupation of the QD is thus necessary. This is usually achieved by counting electrons with proximal charge sensors, e.g. 5 quantum point contacts, single electron transistors (SET), or capacitively coupled electrodes.

[008] The next requirement is the ability to initialize all the qubits to a known state. It is performed in some implementations by applying an external magnetic field to polarize the spins, as depicted in Figure 2c.

[009] Once spins are initialized, the actual computation can begin. A computation can be 10 executed by an adequate combination of single spin rotations (R) and exchange coupling between neighboring spins (J) (Figure 2f). Arbitrary single spin rotations are generally realized with the application of electron spin resonance (ESR) pulses (Figure 2d). Being a very short range interaction, the exchange coupling is turned on and off by modulating the tunnel barrier between adjacent quantum dots (Figure 2e).

15 **[0010]** Finally, the ability to readout some or preferably all of the qubits is necessary to determine the result of a quantum calculation. In some implementations, this can be obtained by spin dependant tunneling to the reservoir, where the electron occupation in the dot remains one if the spin is up, and becomes zero if the spin is down. The change in occupation is detected by charge sensing (Figure 2g).

20 **[0011]** In some attempts, control of coherent electron spin states in quantum dots is limited by short coherence times (very short stability of the superposition state). In this sense qubits are very fragile entities. The challenge is to protect the state of a qubit from the surrounding environment long enough to achieve a sufficient number of logic operations on the quantum state for useful 25 calculations. In order to achieve this feat, the surrounding environment has to be controlled to the fullest extent possible. It has been demonstrated that isotopically enriched ^{28}Si substrates offers sufficiently long coherence times for robust quantum computing with spin qubits in quantum dots.

Quantum dots

[0012] Many architectures for quantum dots have been proposed. Prior art comes in two forms: arena designs and local accumulation designs. Both forms have been successful in demonstrating several functionalities necessary to quantum computation.

[0013] Arena designs rely on electrostatic gates to deplete regions of a two-dimensional electron gas (2DEG), formed by a heterostructure and/or by a global accumulation gate. Figure 3A is a typical implementation published in the literature. The electrostatic gates (dashed structures) define two quantum dots, QD1 and QD2, tunnel coupled to each other and to reservoirs R1 and R2. A nearby single electron transistor (SET) formed by reservoir R3, QD3 and reservoir R4 is used as a charge sensor of the Double-Quantum-Dot (DQD). Barrier gates 341, 342 and 343 control the tunnel barriers between the reservoirs and the dots, represented by the double arrows. Barrier gates 342 and 331 control the tunnel barrier between the dots, also represented by arrows. Confinement gates 351 to 354 define the size of quantum dots. Plunger gates 352 and 353 set QD1 and QD2 charge states. Gate 371 sets the tunnel barriers and the charge state of the SET. The region labeled 2DEG represents electrons not confined by the gates. The scale bar indicates typical structure dimension in GaAs devices.

[0014] Figure 3B shows a cross section of the arena device in Fig 3A, following a section along the points A and B in Fig 3A. The 2DEG is formed in the quantum well layer 393 of the heterostructure 392. The depletion gates, such as 371, 351, and 354, deplete regions of the 2DEG to form the quantum dots QD3, QD1 and QD2. Figure 3C shows a cross section of a device employing a global top gate (395) to create the 2DEG. The depletion gate layout is similar to the one of the device in Figure 3A. A dielectric layer 394 isolates the depletion gates such as 371, 351, and 354, from the global top gate. Layer 391 is the gate oxide that isolates the 2DEG from the gates.

[0015] In local accumulation designs, dots and/or reservoirs can be formed directly by local accumulation gates instead of a combination of a global accumulation gate and electrostatic gate areas. Additional gates increase the confinement of accumulated regions and control the tunnel barriers. For example, in the article by Teck Seng Koh, John King Gamble, Mark Friesen, M. A. Eriksson, and S. N. Coppersmith titled Pulse-Gated Quantum-Dot Hybrid Qubit published in Physics Review Letters, PRL 109, 250503 (2012), there is disclosed a device geometry for a top-gated Si/SiGe heterostructure as illustrated in Figure 4A. The Koh et al. article is also related to

US patent application publication 2015/0279981 published on October 1, 2015. The quantum dot well is provided using an accumulation gate, while the reservoir is provided using a depletion mode tunnel barrier gate and confinement in the well is enhanced using various depletion mode gates. Figure 4B is a further state of the art implementation published in the literature. Two
5 quantum dots, QD1 and QD2, are connected in series to reservoir R2. A proximal single electron transistor formed by reservoir R3, QD3 and reservoir R4 is used as a charge sensor of the double quantum dot DQD. The quantum dots and reservoirs are defined by accumulating electrons under electrostatic gates 401, 402, 412, and 421. Gate 451 ensures lateral confinement of the double quantum dot. Gates 431, 442, 473, and 474 control tunnel barriers between accumulated regions.
10 The scale bar indicates typical structure dimension in Si devices.

[0016] Figure 4C shows a cross section of the local accumulation device in Fig 4B, following a section along the points A and B in Fig 4B. While it is not apparent in Figure 4A for clarity, the different gates are stacked one on the other as depicted in Fig 4C. A thin oxide (not shown) covers each gate to insulate it from the others. Gates 401, 402, 412 and 421 accumulate locally the QDs
15 and reservoirs, while gate 451 laterally confines QD1 and QD2. Gate 431 control the tunnel barrier between QD1 and QD2, and gate 442 controls the tunnel barrier between QD2 and R2.

Summary

[0017] The transistor is the basis of information technology, the elementary unit of supercomputers predicting weather and the basis of portable computing providing access to
20 knowledge to the whole world. The efficiency of transistors to process information resides in their integration by the millions into integrated circuits enabled by Complementary Metal-Oxide-Semiconductor (CMOS) technology, a class of integrated circuits. CMOS technology has enabled the era of information technology. The present invention facilitates a second information technology revolution using CMOS, by simplifying information processing in a quantum
25 computer. Quantum computing seeks to exploit the properties unique to “the world of the very small” to solve complex problems. But the full potential of quantum computers has not been yet imagined.

[0018] Spin qubits in quantum dots are a promising platform for quantum information processing. The present invention allows to simplify the implementation and control of spin qubits

in a scalable fashion using CMOS compatible technology, thus harnessing the full potential of the semiconductor industry for large scale integration and manufacturing.

[0019] It has been discovered that tunneling control between reservoirs and quantum dots can be simplified both in terms of wafer level fabrication and in terms of methods of control.

5 **[0020]** A quantum dot architecture having a split accumulation gate geometry is provided. The architecture includes a reservoir gate, a quantum dot gate, and a spatial gap between the two gates. The gates are placed on top of a semiconductor substrate, with or without an intermediate insulating or oxide layer. The reservoir gate is used to accumulate electrons in the substrate underneath, forming a reservoir. The electrons can originate from doped regions in the substrate,
10 far from the quantum dot. The quantum dot gate is used to attract underneath one or more electrons from the reservoir in a controlled fashion, forming a quantum dot with a tunable discrete number of electrons. The gap between the two gates creates a natural tunnel barrier between the reservoir and the quantum dot. The split gate geometry allows tuning of this tunnel barrier, and thus control of the electron tunneling rate between the dot and the reservoir, with no need for an additional
15 dedicated barrier gate, such as 442 in Fig 4B and 4C.

[0021] Various configurations of the split accumulation gate geometry are provided for incorporation into a quantum dot array. Such an array can be used to form a quantum processing unit. Various embodiments of quantum processing units based on the split gate geometry are also provided. Examples are provided on how quantum computing requirements such as single qubit
20 and two qubits control, readout, and initialization can be integrated to those quantum processing units.

Brief Description of the Drawings

[0022] The proposed solution will be better understood by way of the following detailed description of embodiments of the invention with reference to the appended drawings, in which:

25 **[0023]** Figure 1 is an illustration of the Bloch sphere showing the possible states of a qubit as points on its surface. The arrow pointing to a cross on the surface of the sphere represents an arbitrary superposition of the basis states 0 and 1;

- 5 **[0024]** Figure 2A is a schematic diagram illustrating a quantum dot array of a quantum processing unit before initialization in accordance with a standard sequence for quantum computation;
- [0025]** Figure 2B is a schematic diagram of charge initialization of a quantum dot array of a quantum processing unit in accordance with a standard sequence for quantum computation;
- [0026]** Figure 2C is a schematic diagram of spin initialization of a quantum dot array of a quantum processing unit in accordance with a standard sequence for quantum computation;
- 10 **[0027]** Figure 2D is a schematic diagram illustrating electron spin rotation R of an electron trapped in a quantum dot of a quantum processing unit with an ESR pulse, in accordance with a standard sequence for quantum computation;
- [0028]** Figure 2E is a schematic diagram illustrating exchange coupling J of two electron spins by exchange interaction in two adjacent quantum dots of a quantum processing unit in accordance with a standard sequence for quantum computation;
- 15 **[0029]** Figure 2F is a schematic diagram illustrating a quantum computation decomposed into a specific sequence of electron spin rotations R and exchange coupling J acting on an array of qubits, represented as horizontal wires labeled i ;
- [0030]** Figure 2G is a schematic diagram illustrating electron spin readout using spin-dependant tunneling. The top panel corresponds to the case where the spin orientation of the electron does allow tunneling to the reservoir, and the bottom panel corresponds to the case where the spin orientation of the electron does not allow tunneling to the reservoir;
- 20 **[0031]** Figure 3A is a schematic diagram showing a prior art implementation of an arena dual quantum dot;
- [0032]** Figure 3B is a schematic diagram showing a cross-sectional view through the layer structure of the prior art dual quantum dot implementation shown in Figure 3A;
- 25 **[0033]** Figure 3C is a schematic diagram showing a cross-sectional view through the layer structure of another prior art implementation of an arena design dual quantum using a global accumulation gate;

- [0034]** Figure **4A** is a schematic diagram of a device geometry for a top-gated Si/SiGe heterostructure in which the quantum dot well is provided using an accumulation gate, while the reservoir is provided using a depletion mode tunnel barrier gate and confinement in the well is enhanced using various depletion mode gates;
- 5 **[0035]** Figure **4B** is a schematic diagram showing a prior art implementation of a local accumulation design dual quantum dot;
- [0036]** Figure **4C** is a schematic diagram showing a cross-sectional view through the layer structure of the prior art dual quantum dot implementation shown in Figure **4B**;
- [0037]** Figure **5A** is a schematic diagram illustrating an embodiment of the split gate structure;
- 10 **[0038]** Figure **5B** is a schematic diagram illustrating a cross-sectional view of the embodiment of the proposed solution of Figure **5A**;
- [0039]** Figure **5C** is a schematic diagram illustrating the energy position of the conduction band minima in the semiconductor substrate, as defined by the electric potential of the gates and the spatial gap composing the embodiment of the proposed solution of Figure **5A**;
- 15 **[0040]** Figure **6A** is a schematic diagram illustrating a split gate quantum dot array structure in accordance with an implementation of the embodiment of the proposed solution;
- [0041]** Figure **6B** is another schematic diagram illustrating a split gate quantum dot array structure in accordance with another implementation of the embodiment of the proposed solution;
- [0042]** Figure **6C** is another schematic diagram illustrating a split gate quantum dot array structure in accordance with another implementation of the embodiment of the proposed solution;
- 20 **[0043]** Figure **6D** is another schematic diagram illustrating a split gate quantum dot array structure in accordance with another implementation of the embodiment of the proposed solution;
- [0044]** Figure **6E** is another schematic diagram illustrating a split gate quantum dot array structure in accordance with another implementation of the embodiment of the proposed solution;
- 25 **[0045]** Figure **6F** is another schematic diagram illustrating a split gate quantum dot array structure in accordance with another implementation of the embodiment of the proposed solution;

- [0046]** Figure 7A is a scanning electron microscope image showing plan view of a wafer level implementation of a prototype quantum dot device in accordance with the proposed solution;
- [0047]** Figure 7B is a schematic plot showing experimental data obtained in operating the quantum dot prototype in accordance with the proposed solution;
- 5 **[0048]** Figure 7C is a schematic plot showing experimental data obtained in operating the quantum dot prototype in accordance with the proposed solution;
- [0049]** Figure 7D is a schematic plot showing numerical simulations data obtained in simulating the operation of the quantum dot prototype in accordance with the proposed solution;
- [0050]** Figure 7E is a schematic plot showing experimental data obtained in operating the quantum dot prototype in accordance with the proposed solution;
- 10 **[0051]** Figure 8 is a schematic diagram illustrating an implementation of capacitive charge sensing in the split gate quantum dot array structure illustrated in Figure 6B;
- [0052]** Figure 9A is a schematic diagram illustrating electron spin rotation of electrons trapped in the quantum dot array in accordance with an implementation of the embodiment of the proposed solution illustrated in Figure 6B, by the ESR method;
- 15 **[0053]** Figure 9B is a schematic diagram illustrating electron spin rotation of electrons trapped in the quantum dot array in accordance with an implementation of the embodiment of the proposed solution illustrated in Figure 6B, by the EDSR method;
- [0054]** Figure 10A is a schematic diagram illustrating coupling by exchange interaction of electrons trapped in the quantum dot array in accordance with an implementation of the embodiment of the proposed solution illustrated in Figure 6B, using tuning of the barrier;
- 20 **[0055]** Figure 10B is a schematic diagram illustrating coupling by exchange interaction of electrons trapped in the quantum dot array in accordance with a modification of the implementation of the embodiment of the proposed solution illustrated in Figure 6B, using detuning between the dots;
- 25 **[0056]** Figure 10C is a schematic diagram illustrating coupling by exchange interaction of electrons trapped in the quantum dot array in accordance with a modification of the implementation of the embodiment of the proposed solution illustrated in Figure 6E, using a dot as a coupler;

[0057] wherein similar features bear similar labels throughout the drawings. While the layer sequence described is of significance, reference to “top”, “bottom”, “left” and “right” qualifiers in the present specification is made solely with reference to the orientation of the drawings as presented in the application and do not imply any absolute spatial orientation.

5 Detailed Description

[0058] In some embodiments, there is provided a method of forming a quantum dot and a reservoir and controlling the rate of transfer of charges, namely electrons or holes, between them in a semiconductor device for use in a quantum computer. The method can comprise using a split gate geometry for the accumulation gates of the quantum semiconductor device, where a distinct gate is used to form a quantum dot, and another distinct gate is used to form the reservoir for the quantum dot, with a spatial gap between the two gates.

[0059] The split gate geometry is illustrated in Figure 5A. A positive voltage applied on gate 511 defines the reservoir R in the semiconductor substrate underneath. A positive voltage applied on gate 501 defines the quantum dot QD in the semiconductor substrate underneath. The spatial gap between the two gates is labeled S, and it defines a tunnel barrier T in the semiconductor substrate underneath. Scale bar indicates typical dimensions in a silicon device. Figure 5B shows a schematic cross-sectional view of the quantum semiconductor device including a split gate geometry and the regions it defines in a semiconductor substrate. Region 590 is the accumulation gate layer, with 501 the QD accumulation gate, 511 the reservoir accumulation gate, and S the spatial gap. Region 591 is the dielectric layer isolating the gates from the substrate (592). The reservoir R, the quantum dot QD, and the tunnel barrier T are formed at the interface between regions 591 and 592.

[0060] Figure 5C shows the energy of the conduction band following the axis reservoir-dot in the device illustrated in Figure 5A and 5B when positive voltages are applied on gates 501 and 511. The reservoir R is filled with electrons occupying a continuum of energies, and the quantum dot QD presents discrete energy levels, indicated by horizontal lines. Between the dot and the reservoir, the tunnel barrier T sets the tunneling rate Γ of electrons. The barrier is often characterized by its height h and width w . Tuning of the barrier involves modifying h and/or w and can affect Γ .

[0061] The method for controlling the rate of transfer of electrons between an electron reservoir and a quantum dot in a semiconductor device presenting a split gate geometry as described above can comprise adjusting the potential of the reservoir accumulation gate to adjust the transfer rate of electrons between the reservoir and its corresponding dot and compensating accordingly the voltage on the dot accumulation gate to maintain the dot occupation number constant. The split gate geometry, using only two gates and a spatial gap between them, can perform reservoir formation, quantum dot formation, and tunnel rate control. With prior art implementations of local accumulation devices, those three functionalities are performed with accumulation gates for reservoirs and quantum dots formation, and one or more barrier gates for tunnel rate control.

[0062] The invention as described could be used to simplify design and control of local accumulation quantum dots in silicon, silicon germanium heterostructures, gallium arsenide heterostructures, or any other standard semiconductor substrates.

[0063] Fig 6A is an implementation of a quantum dot array using the invention. The proposed geometry illustrated in Figure 5A can be used to form a QD array. The elementary unit 600a of the architecture illustrated in Figure 6A, is composed of the reservoir gate 611, QD charge gate 601, spatial gap S, QD confinement gate 651, reservoir confinement gate 661 and coupling gate 631. A positive voltage applied on gates 611 and 601 will form the reservoir R and the quantum dot QD, as well as the tunnel barrier T separating them. Confinement gates 651 and 661 help confining the regions associated with the quantum dots and the reservoirs, respectively, when a negative voltage is applied to them. Modifying the voltage applied to coupling gate 631 will control the tunnel barrier between two adjacent quantum dots, which is important for two-qubit operations. This arrayed chain is illustrated as having 3 quantum dots with more on each side. The elementary unit 600a can be repeated as much as needed to provide an arrayed chain of quantum dots of any desired length. As illustrated in Figure 6A, gates 601 influence (are connected to) the QDs from the top using 3D wafer level fabrication techniques.

[0064] It will be appreciated that the embodiment of Figure 6A provides control for the reservoir accumulation mainly via gate 611 and the QD charge occupation mainly via gate 601, and provides a simplified control over the tunnel properties in terms of number of required gates over prior art implementations, such as the one illustrated in Figure 4A in which an additional

depletion mode gate is used to control the tunnel rate, by using only gates 611 and 601 and no dedicated barrier gate to control the tunnel rate.

5 **[0065]** The split gate geometry can be adapted for 2D wafer level fabrication techniques for example as illustrated schematically in Figure 6B. In accordance with this implementation of the embodiment of the invention, two confinement gates 651 and 653 can be employed instead of one, to deplete the region under the arm of gate 601 when a positive voltage is applied to it. Alternatively, in accordance with another embodiment of the invention, illustrated in Figure 6C, a single confinement gate 651 could be used. Scale bars in Figures 6A, 6B and 6C illustrate typical dimensions needed for the implementation of every function of a scalable quantum information
10 processing device in a silicon substrate.

[0066] The arrangement of the reservoirs R need not be on one side of the device. Alternatively, reservoirs can be arranged as desired, for example alternatingly on different sides as illustrated in Figure 6D and 6E. It will be appreciated that the quantum dots and reservoirs need not be arranged in a straight line but can follow different arrangements that permit controlled
15 coupling between the qubits, whether a curved line or a staggered pattern.

[0067] Coupling gates between the quantum dots QD need not be present, as illustrated in Figure 6E.

[0068] A second reservoir R can be added in series with the first reservoir and the quantum dot to perform transport measurements. This is illustrated in Figure 6E, where the QD gate 601 is
20 placed in between the reservoir gates 611 and 612 so that a current can flow across the reservoir under 611 through the QD under 601 and across the reservoir under 612. The reservoirs need not be arranged in front of one another to perform transport measurement. The arrangement of Figures 6A, 6B, 6C, 6D and 6E also allow transport from one reservoir to another through QDs in series with them, such as from the reservoir under 611a to the reservoir under 611b through QDs under
25 gates 601a and 601b successively.

[0069] Figure 7A illustrates a plan view of a QD structure implemented in accordance with the proposed solution demonstrating tunnel rate control, dot formation and reservoir formation with the split gate geometry. All gates are 2D wafer level manufactured of polycrystalline silicon. A positive voltage is applied on gate 711 to form the reservoirs R1 at the interface between the

substrate and the dielectric layer (like layer 592 in Figure 5B). A positive voltage is applied on gate 701 to form the quantum dot QD1 at the interface between the substrate and the dielectric layer. A positive voltage is applied to gate 722 to form the reservoirs R2 and R3 and the dot QD2 of the SET, to be used as a charge sensor. Gates 773 and 774 help to control the tunnel barriers of the SET, and are operated with negative voltages. Gates 743 and 752 enhance confinement of the SET and are operated with a negative voltage. The voltage applied on gates 731 and 742 helps confine the quantum dot QD1. The current through the SET is measured to obtain the charge state of QD1. A gap exists between gates 701 and 711. This spatial separation forms the tunnel barrier T between QD1 and R1. The axis along the arrow between points A and B is the axis of measurement for Figure 7D.

[0070] Figure 7B illustrates experimental data plots showing the effect of reservoir gate 711 and dot gate 701 on the tunnel rate between the reservoir R1 and the dot QD1. In this stability diagram, gates 701 and 711 are swept through control potentials to navigate the charge states of QD1, and the current through the SET is measured. Charge states are indicated as (N), where N is the number of electrons in QD1. Taking the derivative of the SET current as a function of gate 701 voltage, transitions become visible. Those transitions are designated by arrows and correspond to transitions in the number of electrons in QD1. Inset shows the measured tunnel rate as a function of gate 711 voltage for the colored points on the transition in the background stability diagram. The voltage on gate 701 is also slightly different for each data point, as increasing the voltage on gate 711 moves the dot energy states, and this must be compensated with a diminution of the voltage on gate 701 to keep the number of electrons constant in the quantum dot. Data in the inset indicates an increase in tunnel rate as a function of gate 711 control voltage.

[0071] Figure 7C illustrates an experimental data plot demonstrating a technique for efficient charge initialization in a quantum dot using the proposed solution. In this stability diagram, gates 701 and 711 are swept through control potentials to navigate the charge states of QD1, and the current through the SET is measured. Charge states are indicated as (N), where N is the number of electrons in QD1. Transitions corresponding to transitions in the number of electrons in QD1 are designated by arrows. The region N=0 is identified by the absence of further transitions in the signal. In prior art implementations, where a split gate geometry is not used to control the tunnel rate between the dot and the reservoir, the identification of the N=0 region is complicated by the

fact that further transitions might not be visible because of a too low tunnel rate. In accordance with the proposed solution, sweeping only gates **701** and **711** allows to scan the entire parameter space, going from a lower tunnel rate region to a higher tunnel rate region in a single scan. This principle is demonstrated experimentally in Figure **7B**. This technique is useful to detect the last transition with a single stability diagram, as even if it is not visible in a lower tunnel rate region, it will become apparent in the higher tunnel rate region of the stability diagram.

[0072] Figure **7D** illustrates numerical simulation data obtained in simulating the operation of the quantum dot prototype in accordance with the proposed solution. The conduction band edge along the AB axis shown in Fig 7A is obtained at increasing reservoir gate 711 voltages, from 3 to 4 V, with 0.25 V increments. The simulations show that increase of the gate 711 voltage lowers the tunnel barrier height and reduces its width. This is consistent with the observed associated increase in tunnel rate for experimental data as in Fig 7C.

[0073] Fig 7E shows an experimental data plot obtained from mathematical treatment of the stability diagram of Fig 7C. Data points correspond to the calculated gate to dot capacitance ratio of gates 711 and 701, as a function of the voltage applied to gate 711, for the transition between regions 2 and 3 of Fig 7C. The curve is a fit to the data points, and is approximately exponential. Fig 7E shows that the gate to dot capacitance ratio for gates 711 and 701 diminishes with increased gate 711 voltage. This indicates that the gate 711 becomes less and less efficient at displacing the dot energy level as its voltage is increased.

[0074] In accordance with the proposed solution, formation of a reservoir and a quantum dot and control of tunneling rate between them is provided with a minimal gate count and a single gate stack. This simplification in gate architecture is advantageous for scalability. From an operational perspective, the proposed solution facilitates the control, readout and initialization of multiple quantum dots charge states, since it's possible to attach a reservoir to each dot in a 1D quantum dot array. Furthermore, the proposed solution was demonstrated in a device fabricated by an entirely CMOS compatible process, using a single stack of polysilicon gates and subtractive lithography processes.

Quantum Processing Unit

[0075] Multiple Quantum Dot (QD) structures proposed herein can be used in providing algorithmic and/or logical calculations in a quantum computing unit of a central processing unit. Examples of integration of essential functionalities for quantum computation to QD array structures implemented with the split gate geometry are provided. Those functionalities include (i) charge sensing, (ii) charge initialization, (iii) single spin rotations, and (iv) exchange coupling.

[0076] For simplicity, ancillary electronic components providing: memory storage such as random access memory storage, input data registers, input address registers, output data registers, output address registers, latches, etc. are not illustrated.

[0077] In accordance with the proposed solution, Figure 8 illustrates the architecture of an implementation in which capacitive charge sensing is employed in a QD array structure illustrated in Figure 6B. In this implementation, confinement gate 853a from unit cell 800a is connected to an inductance L and to a radio-frequency source RF-in. Changes in the occupation number of the associated QD modify the capacitance between 853a gate and the QD. This affects the resonance frequency of the RLC resonator, and thus the reflected signal RF-out. Each QD in the array can employ a corresponding charge detection circuit for improved sensitivity. Without limiting the invention, in alternate variant implementations the charge detection circuit could also be integrated to gate 811 or 851. Other implementations could include different readout circuits sensitive to the change in the occupation number of the QDs through their capacitance to field-effect-transistors (FET) or capacitive bridges (see US patents 5,889,288 and 7,830,695). Alternatively, other proximal charge sensors such as single electron transistors can also be included in a quantum dot array in accordance with the proposed solution, as evident with the prototype presented in Figure 7A.

[0078] In accordance with the proposed solution, charge initialization of a quantum dot is obtained by sweeping through control potentials for the reservoir accumulation gate (like gate 811a in Figure 8) and the quantum dot accumulation gate (like gate 801a in Figure 8). The transition indicative of the last electron leaving/entering the quantum dot in the resulting stability diagram is straightforward to identify with the split gate geometry. This is due to the tuning of the tunnel rate, dot occupation, and reservoir density as the two accumulation gates are swept. The last transition will inevitably become apparent when the tunnel rate is high enough, even if it is not visible in a

given regime. In an arrayed chain of quantum dots in accordance with the proposed solution, such a procedure is available to each quantum dot in the array.

5 **[0079]** In accordance with the proposed solution, Figure 9A schematically illustrates functional details of an implementation employing ESR for addressable single electron spin rotations employed in a QD array structure illustrated in Figure 6B. An oscillating current I_{ac} is forced through a high-frequency antenna, producing an oscillating magnetic field B_{ac} having a frequency f_{ac} . A property referred to as the Zeeman energy E_Z of the electron spin in the QD under gate 901a is initially off-resonance with B_{ac} . The transverse electric field E_x can be controlled by applying a pulse of voltage V on the accumulation gate 901a, which affects the g-factor g of the electron, bringing E_Z into resonance with f_{ac} . Other QDs in the array will not be brought into resonance by this procedure applied to the gate 901a. The duration Δt of the pulse determines the amplitude of the spin rotation, while its phase determines the angle of rotation on the Bloch sphere. Every qubit in the chain (QD array) can be individually addressed by connecting each 901 gate to a corresponding pulsing circuit.

15 **[0080]** In accordance with the proposed solution, Figure 9B schematically illustrates functional details of another implementation employing Electron Dipole Spin Resonance (EDSR) for addressable single electron spin rotations employed in a QD array structure illustrated in Figure 6B. An asymmetrical strip of ferromagnetic material with magnetization M , positioned on top of gate 911 for each qubit cell, provides an inhomogeneous transverse magnetic field B_x for each QD. 20 The external magnetic field component B_z sets the Zeeman energies E_Z of the QDs. An AC pulse of voltage V and frequency f_{ac} , in resonance with E_Z of the addressed electron is applied to gate 951 and/or 953 of the corresponding unit cell to oscillate the electron's position in the QD. In combination with the transverse magnetic field produced by the ferromagnetic strip which also has an inhomogeneous component B_x , applying the AC pulse produces an effective oscillating 25 magnetic field B_{ac} in resonance with E_Z . The g-factor of each trapped electron in the chain can be individually tuned using its gate 901, which ensures a dot-specific Zeeman energy. Consequently, other QDs in the array will not be brought into resonance by the pulse applied to the confinement gates of the addressed electron. The duration Δt of the pulse determines the amplitude of the spin rotation, while its phase determines the angle of rotation on the Bloch.

[0081] While not explicitly illustrated in Figures 8, 9A and 9B, the person skilled in the art will understand that the semiconductor device further comprises control circuitry connected to the reservoir accumulation gate and the quantum dot accumulation gate for applying to the reservoir gate and the quantum dot gate a common polarity electrical potential to defines the tunnel barrier height, width and charge tunneling rate between the quantum dot well and the electric charge reservoir without relying on any barrier gate to control the charge tunneling rate. Such circuitry can also control voltages applied to the gates for setting charges in the quantum dot reservoirs, control charge movements, and/or control spin state setting and readout.

[0082] The control circuitry can comprise but is not limited to: voltage sources, current monitors, voltage-to-current converters, attenuators, amplifiers, bias-tee to combine AC and DC signals, high frequency (radio-frequency and microwave) sources, pulse generators, lock-in amplifiers, RLC circuits, filters. The control circuitry can either be connected externally to the quantum dot device, in a similar fashion to what is described in the article titled “An addressable quantum dot qubit with fault-tolerant control fidelity” by Veldhorst et al. and published in Nature Nanotechnology 9, 981 (2014), or it could be integrated, in parts or in its entirety, directly to the quantum dot structure to form a single device, following proposals in the article titled “Silicon CMOS architecture for a spin-based quantum computer” by M. Veldhorst et al., arXiv:1609.09700 (2016) and in the article titled “Interfacing spin qubits in quantum dots and donors - hot, dense and coherent” by L. M. K. Vandersypen et al., arXiv:1612.05936 (2016).

[0083] In accordance with the proposed solution, Figure 10A illustrates the architecture of an implementation in which exchange coupling is employed in a QD array structure illustrated in Figure 6B. The coupling between two neighboring electrons formed under gates 1001a and 1001b is provided by switching on the exchange interaction J by increasing the voltage V applied on barrier gate 1031a. Increasing the voltage V on gate 1031a lowers the tunnel barrier between the two dots QDa and QDb, as illustrated in the schematic associated with the $J > 0$ region of the V versus t graph. The schematic shows the energy minima of the conduction band along the two adjacent quantum dots when the dot accumulation gates 1001a and 1001b are activated with a positive voltage. The horizontal dimension is spatial while the vertical dimension is representative of the conduction band energy. Both quantum dots contain a single electron occupying the discrete energy levels represented by horizontal lines. The arrows indicate the direction of the spin. By

increasing the voltage on barrier gate **1031a** during a finite time interval, the tunnel barrier is lowered, allowing for coupling to occur. As illustrated in the schematic associated with the $J = 0$ region of the V versus t graph, the exchange coupling is turned off by increasing the tunnel barrier energy, which is done by lowering the voltage V applied on gate **1031a**. Alternately, the exchange interaction J could be turned on and off by modulating the energy difference between Qda and QDb (the detuning) with voltages applied to gates **1001a** and **1001b**, as represented in figure **10B**. In this implementation, tunnel barrier gate **1031a** is removed, since by setting the spatial gap between gates **1001a** and **1001b** to a determined value, exchange coupling can be realized only via detuning with gates **1001a** and **1001b**. In another version, the exchange interaction J could be modulated by the number of electrons present in a coupling quantum dot between the two quantum dots of interest, as represented in Fig 10B. In this implementation, there is no need for tunnel barrier gates between the quantum dots. The exchange interaction J between QDa and QDc is turned on and off by the presence or absence of electrons in QDb, respectively. The number of electrons in QDb is tuned by the voltage on gate 1001b. Electrons can be loaded or unloaded to QDb directly through reservoir Rb under gate 1011b.

[0084] The proposed solution can be applied to: solving problems intractable to solve via classical computing such as simulation of physical models (weather prediction, molecular structures, etc.); cryptography; secure communications; etc. Such application would be of interest at least to: scientific research; pharmaceuticals; banking; space exploration; government agencies (agricultural, security, emergency response, population planning, etc.)

[0085] For certainty, process steps presented herein are understood to be employed in either in sequence or in parallel and not limited to the sequence described above.

[0086] While the invention has been shown and described with reference to preferred embodiments thereof, it will be recognized by those skilled in the art that various changes in form and detail may be made therein without departing from the spirit and scope of the invention as defined by the appended

What is claimed is:

1. A semiconductor device for use in a quantum computer, the device comprising:

a reservoir accumulation gate defining an electric charge reservoir in a semiconductor substrate;

a quantum dot accumulation gate defining a quantum dot well in the semiconductor substrate;

a gap between said reservoir accumulation gate and said quantum dot accumulation gate;

wherein said gap is not filled with any physical structure providing a tunnel barrier between said electric charge reservoir and said quantum dot well, and a common polarity electrical potential applied to said reservoir gate and said quantum dot gate defines a tunnel barrier height, width and charge tunneling rate between said quantum dot well and said electric charge reservoir without relying on any barrier gate to control the charge tunneling rate.

2. A semiconductor device for use in a quantum computer, the device comprising an arrangement of quantum dots and their related control structures, the device comprising:

an array of reservoir accumulation gates defining electric charge reservoirs;

an array of quantum dot accumulation gates defining quantum dot wells with each one of said quantum dot gates arranged next to one end of a corresponding one of said reservoir gates with a gap therebetween, wherein said gap is not filled with any physical structure providing a tunnel barrier, a common polarity electrical potential applied to said reservoir gates and said quantum dot gates defining a tunnel barrier height, width and charge tunneling rate between a respective one of said quantum dot wells and said electric charge reservoirs without relying on any barrier gate to control the charge tunneling rate; and

an array of barrier gates, an electrical potential applied to said barrier gates able to control charge spin coupling between charges trapped in said quantum dot wells.

3. The device as defined in Claim 1, further comprising:

an array of control gates arranged near said reservoir gates and said quantum dot gates, an electrical potential applied to said control gates able to confine electrons within said quantum dot wells and said electron reservoirs;

4. The device as defined in Claim 2 or 3, wherein said array of quantum dot gates provides a straight row of said quantum dot wells.
5. The device as defined in any one of Claims 1 to 4, wherein said device is a Complementary Metal-Oxide-Semiconductor (CMOS) device.
6. The device as defined in Claim 5, wherein said device is made using 3D wafer level fabrication techniques.
7. The device as defined in Claim 5, wherein said device is made using 2D wafer level fabrication techniques.
8. The device as defined in Claim 5, wherein said device comprises silicon 28 isotope enriched silicon substrate material.
9. The device as defined in any one of Claims 1 to 8, further comprising control circuitry connected to said reservoir accumulation gate and said quantum dot accumulation gate for applying to said reservoir gate and said quantum dot gate a common polarity electrical potential to defines said tunnel barrier height, width and charge tunneling rate between said quantum dot well and said electric charge reservoir without relying on any barrier gate to control the charge tunneling rate.
10. A method of transferring charges between an electric charge reservoir and a quantum dot in a semiconductor device for use in a quantum computer, the method comprising:
 - providing a gap between a reservoir accumulation gate and a quantum dot accumulation gate in a semiconductor substrate wherein said gap is not filled with any physical structure providing a tunnel barrier;
 - applying a common polarity electrical potential to each of said reservoir gate and said quantum dot gate to create a tunnel barrier between a quantum dot well and an electric charge reservoir in said semiconductor substrate;
 - adjusting the electrical potential to at least one of said reservoir gate and said quantum dot gate to adjust a tunnel barrier height, width and charge tunneling rate between said quantum dot well and said electric charge reservoir without relying on any barrier gate to control the charge tunneling rate;
 - said adjusting being done while detecting a number of charges in the quantum dot well or charge flow between the quantum dot well and the electric charge reservoir in said semiconductor substrate so as to provide in said quantum dot well a predetermined number of electric charges.

11. The method as defined in Claim 10, wherein a positive electrical potential is applied to each of said reservoir gate and said quantum dot gate, said predetermined number of electric charges being a number of electrons.
12. The method as defined in Claim 11, wherein said number of electrons is a single electron.
13. The method as defined in any one of claims 10 to 12, wherein said semiconductor device is as defined in any one of claims 1 to 9.

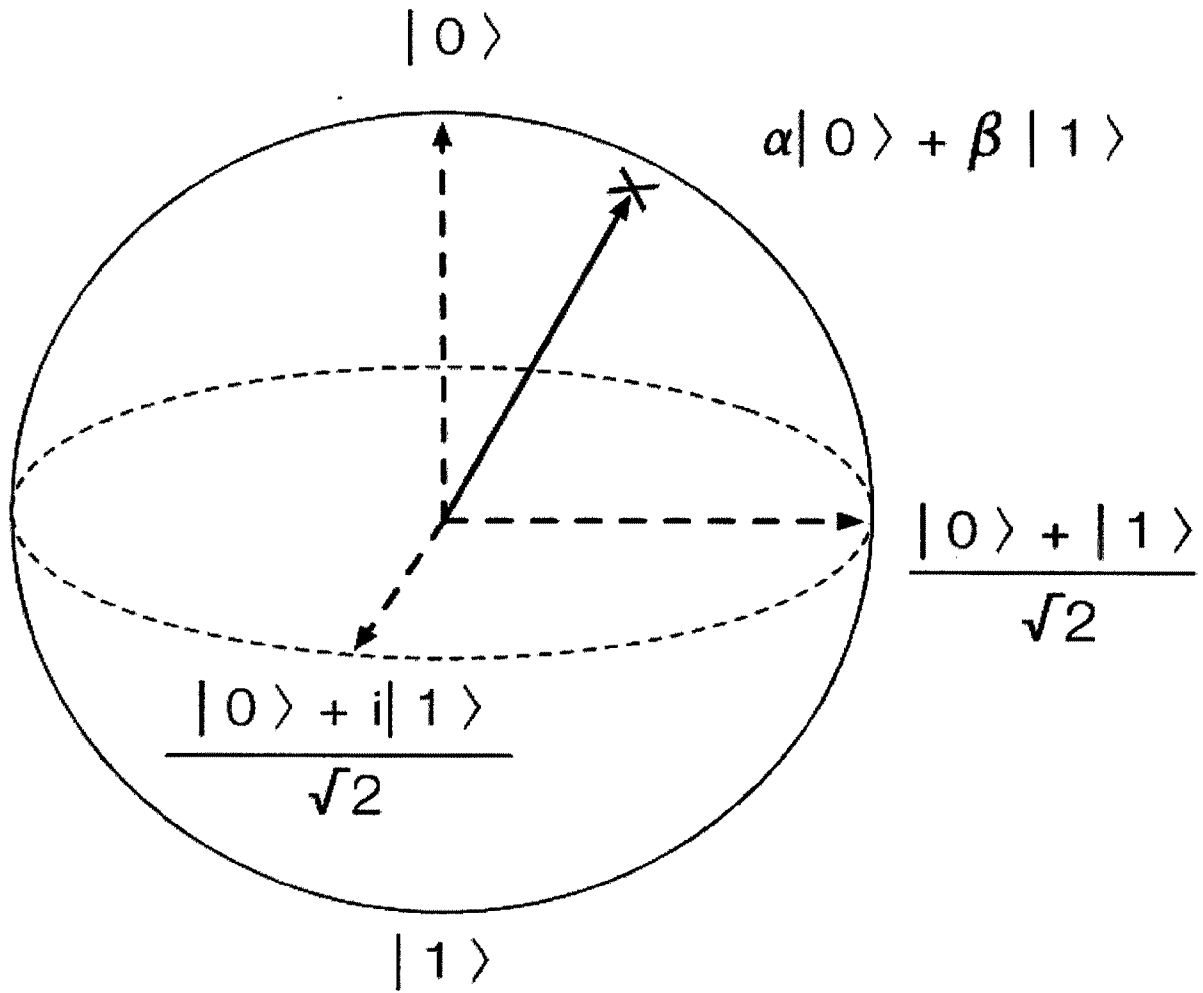
**Figure 1**

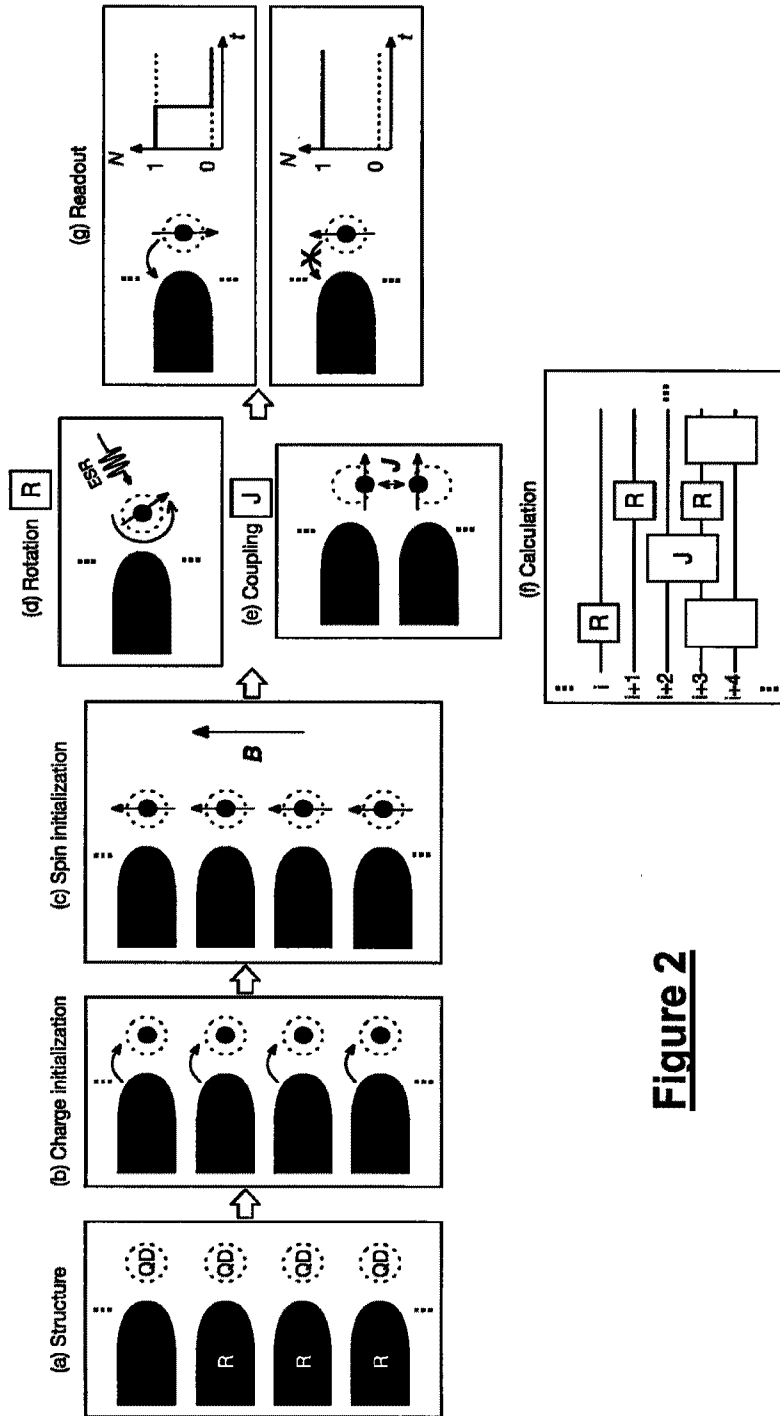

Figure 2

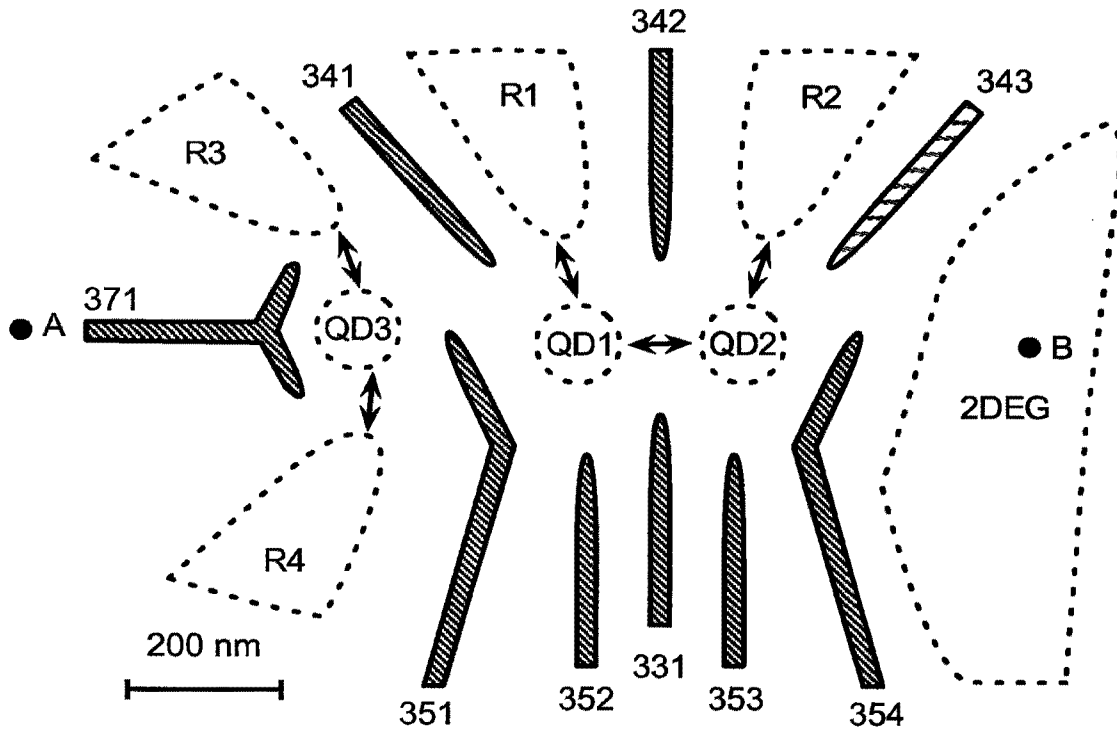

Figure 3A
(PRIOR ART)

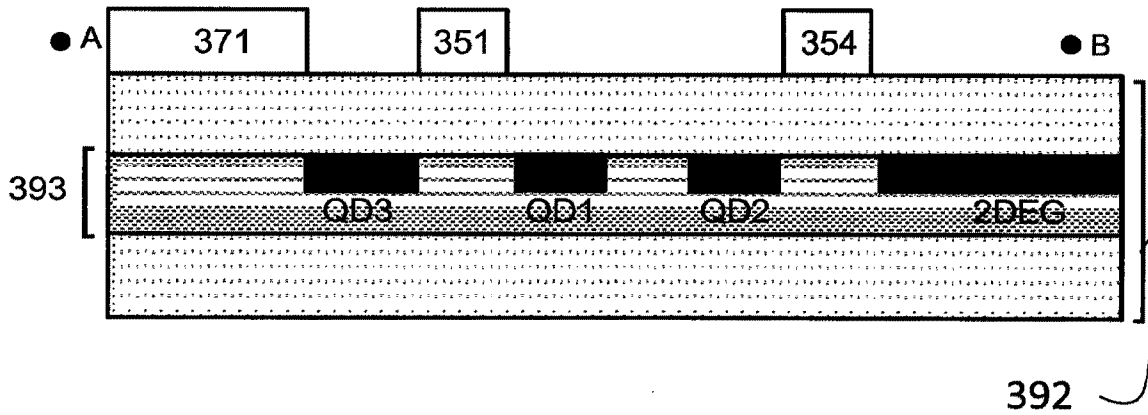

Figure 3B
(Prior art)

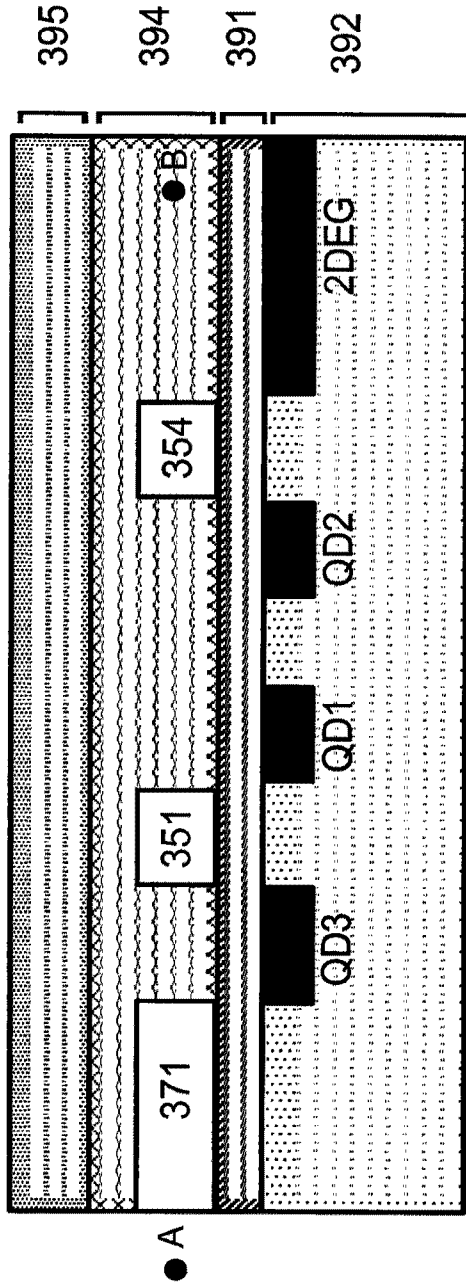

Figure 3C
(PRIOR ART)

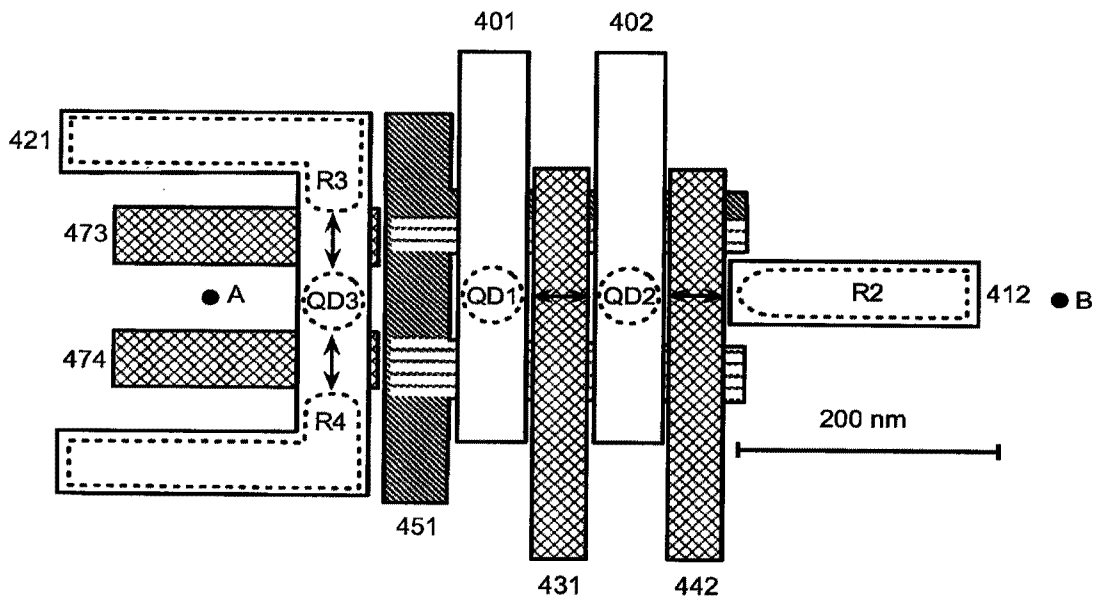
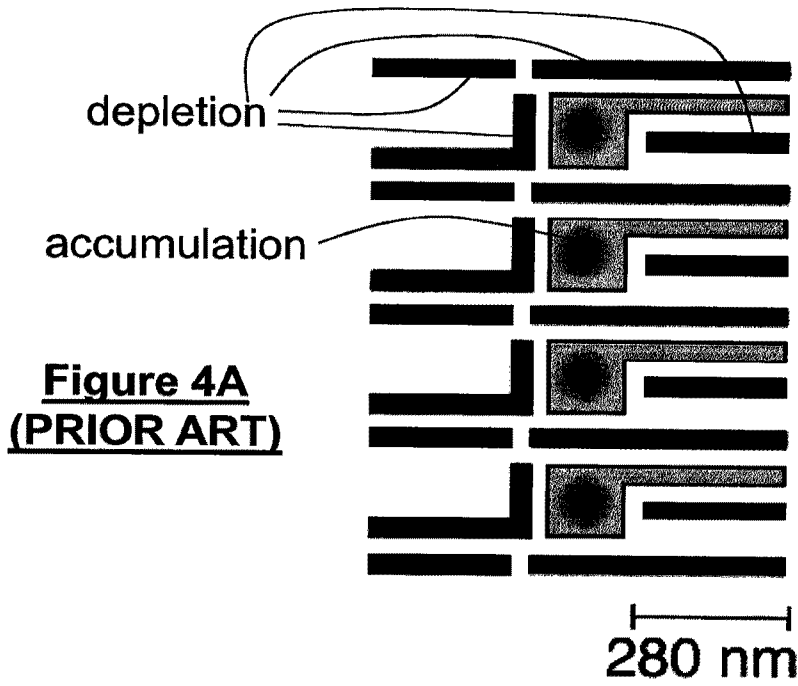

Figure 4B
(PRIOR ART)

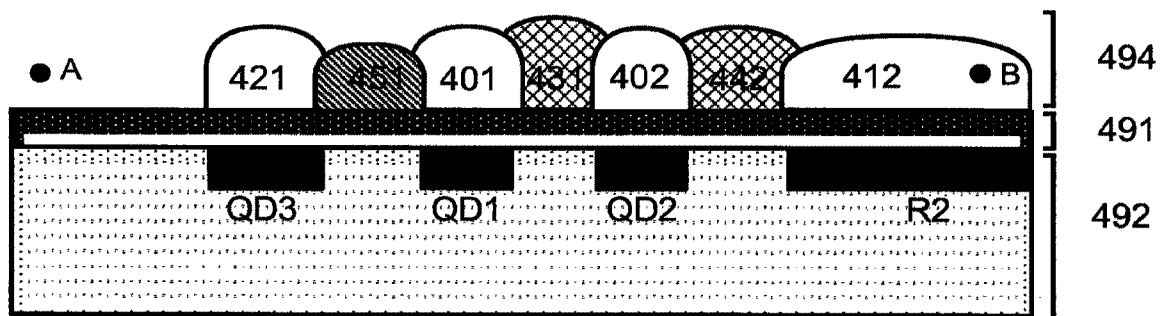

Figure 4C
(PRIOR ART)

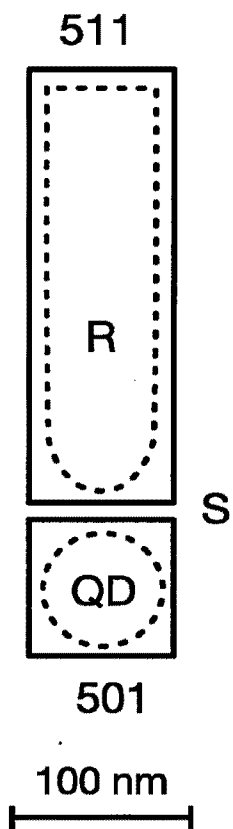

Figure 5A

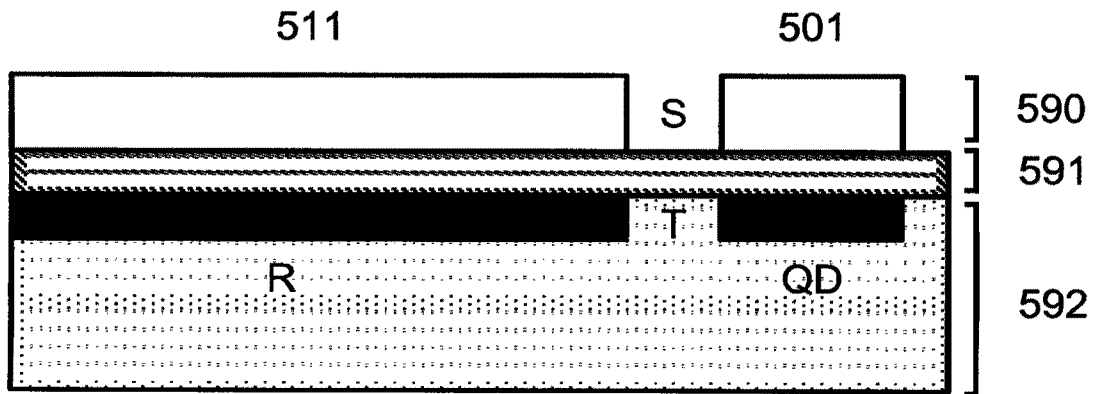

Figure 5B

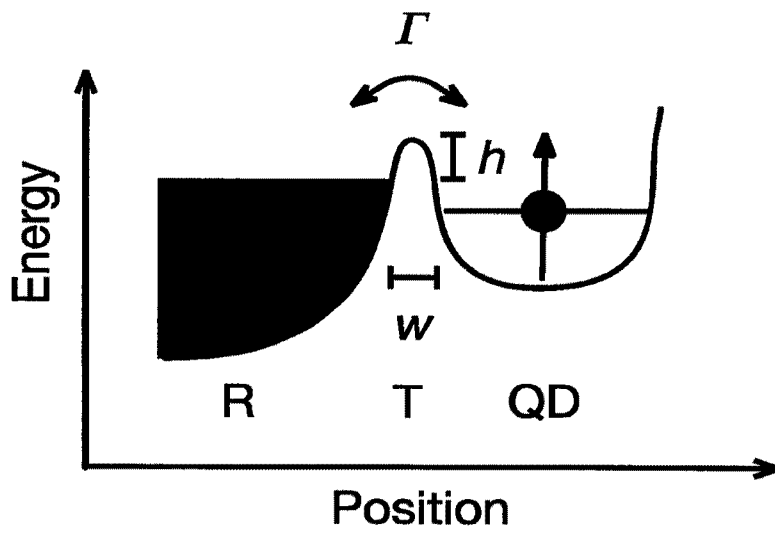

Figure 5C

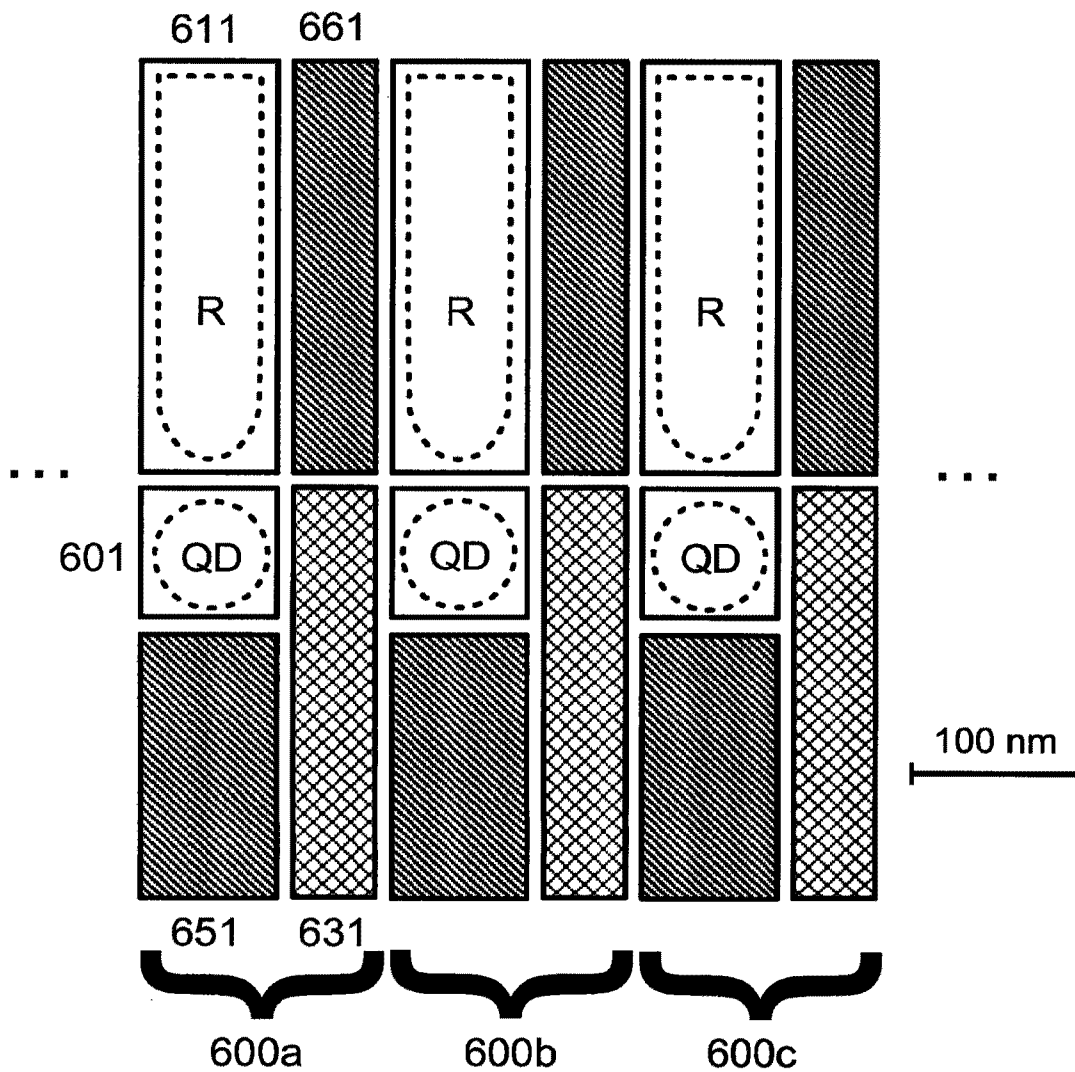

Figure 6A

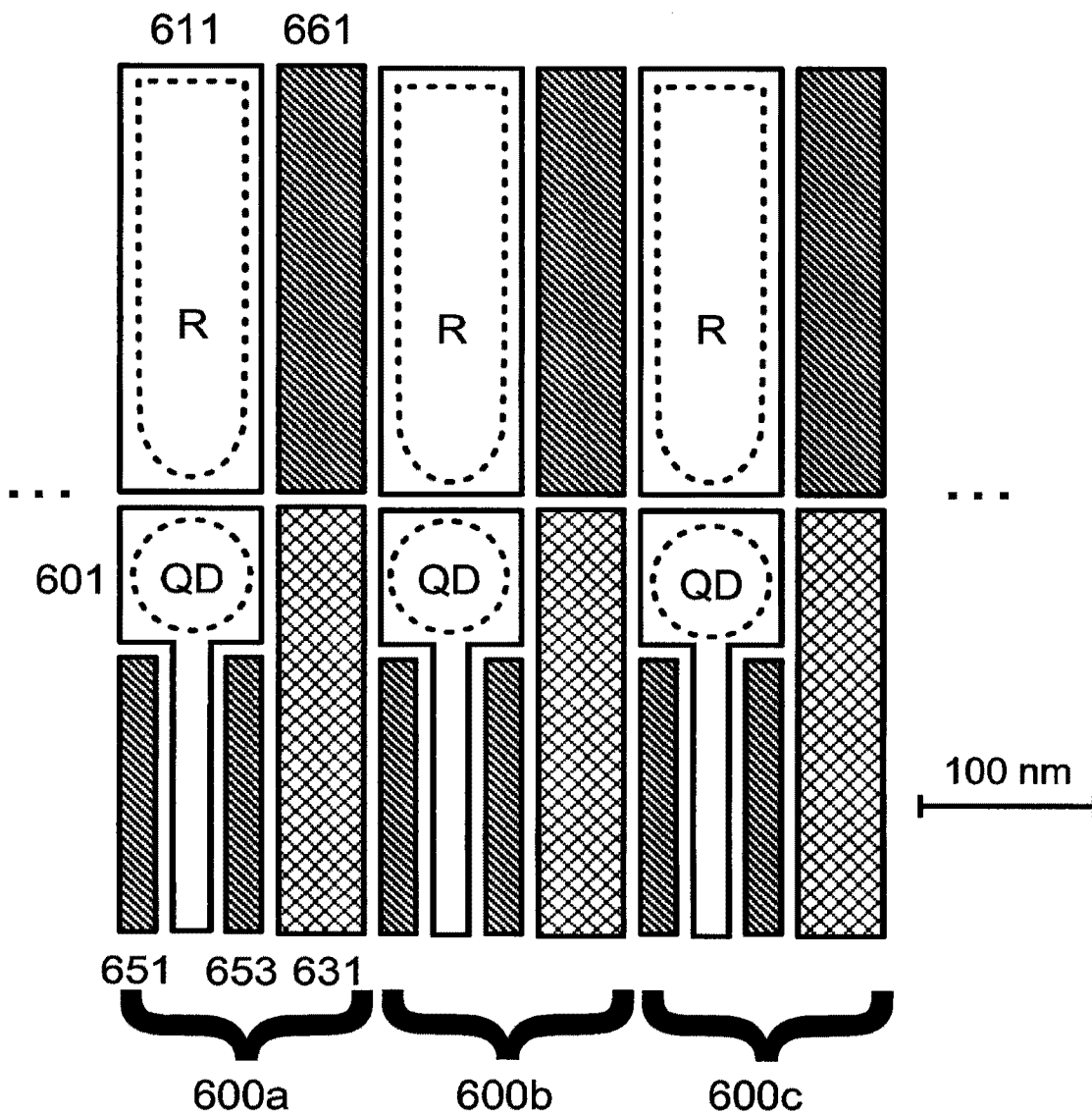

Figure 6B

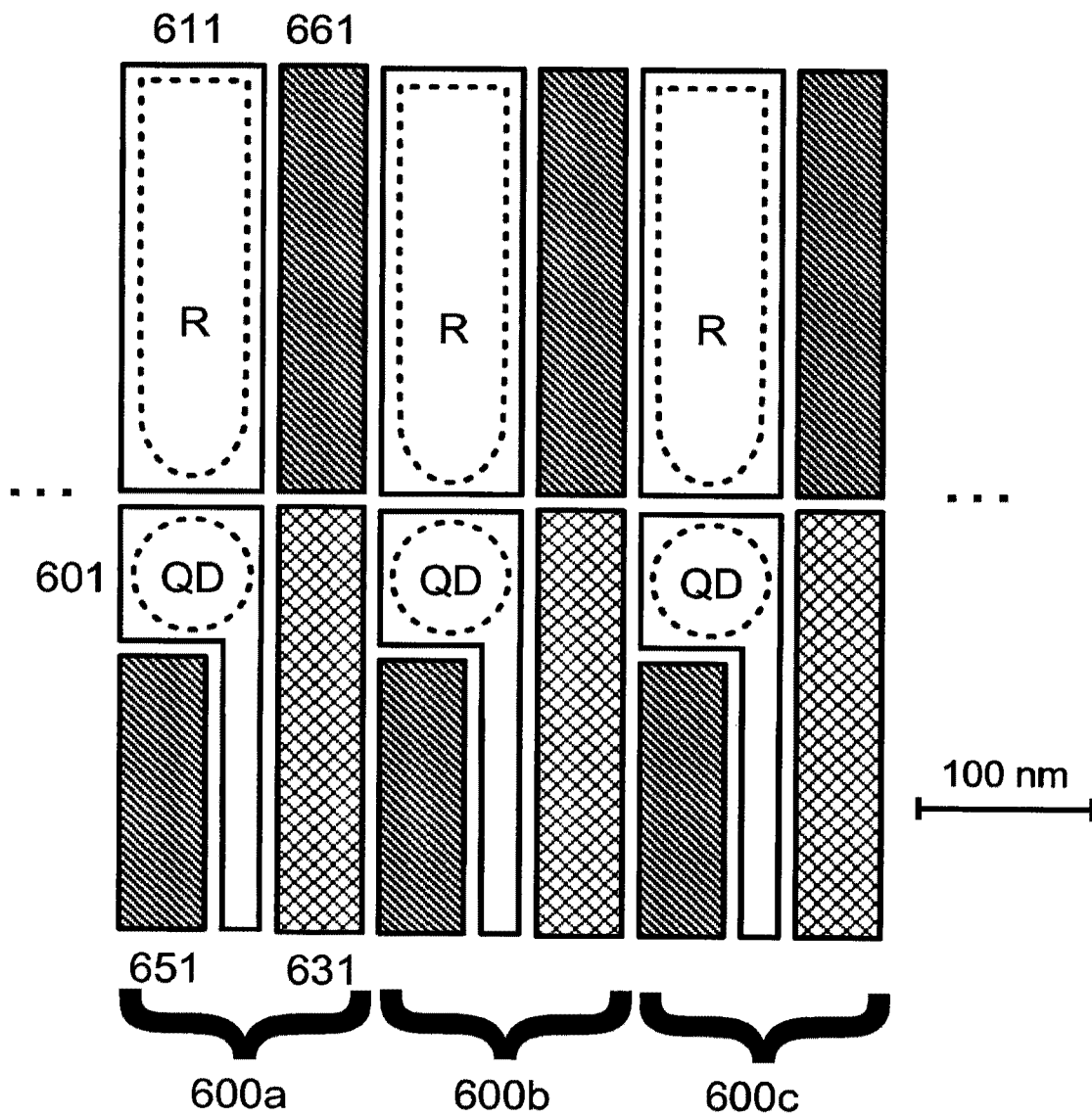

Figure 6C

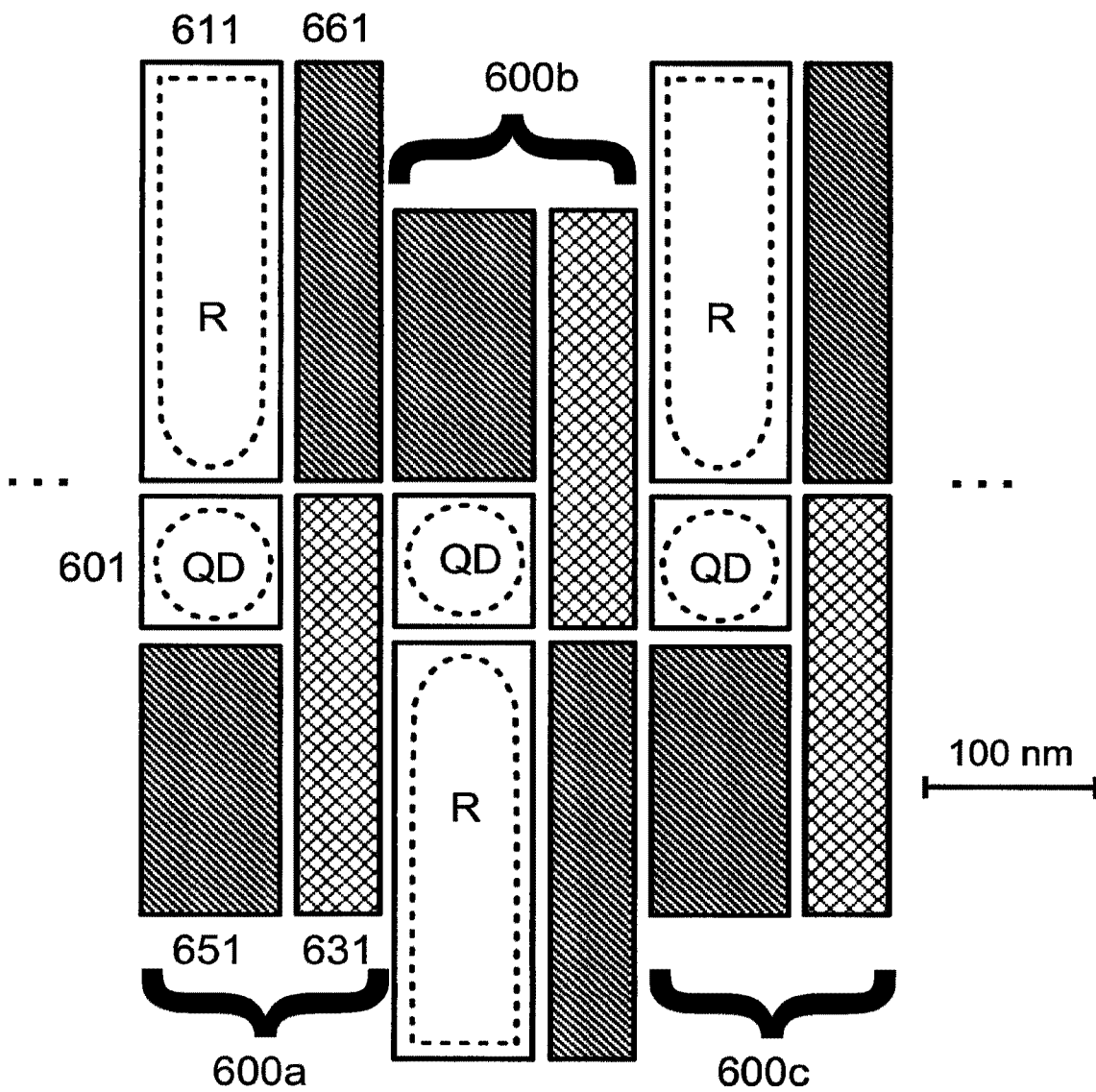

Figure 6D

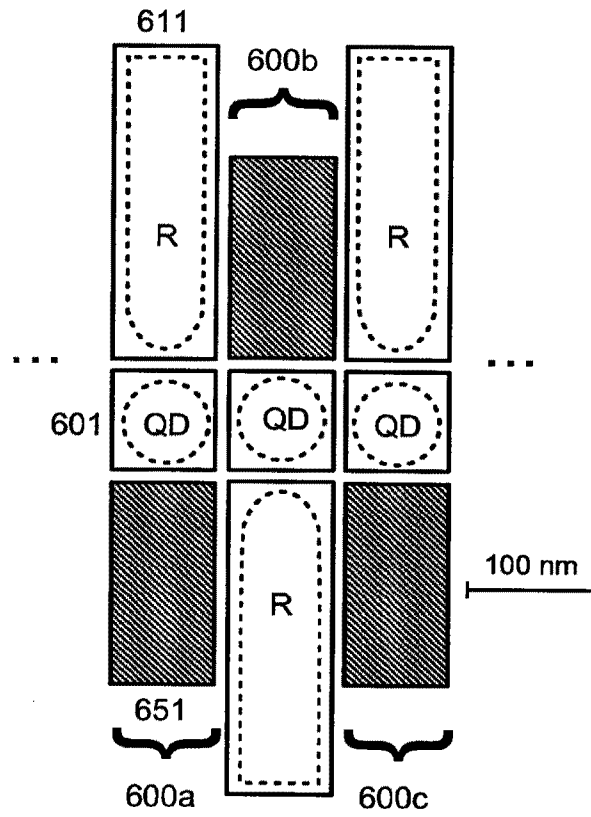

Figure 6E

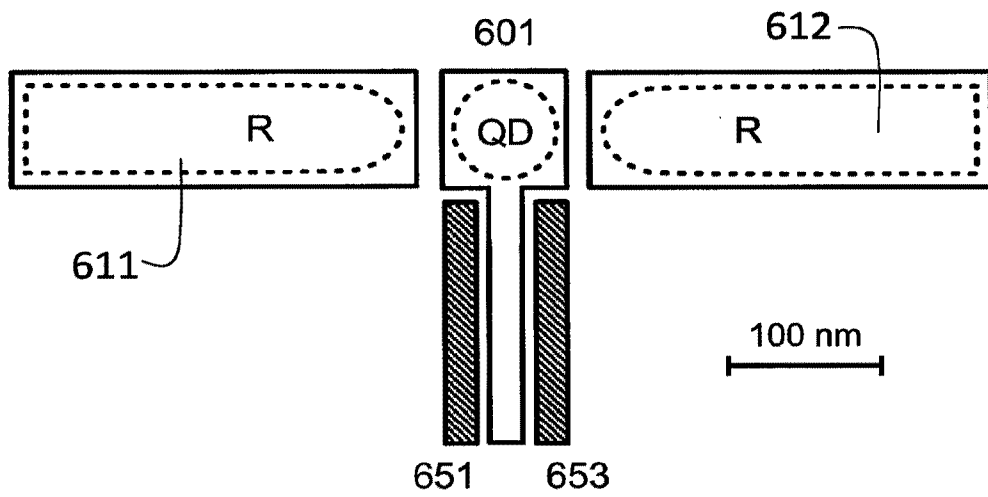

Figure 6F

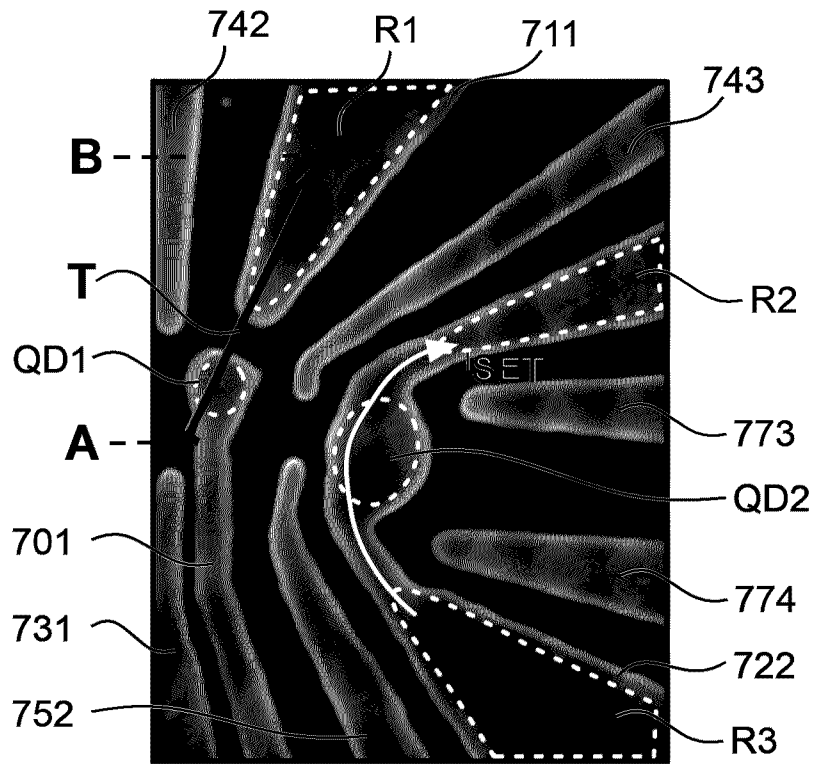

Figure 7A

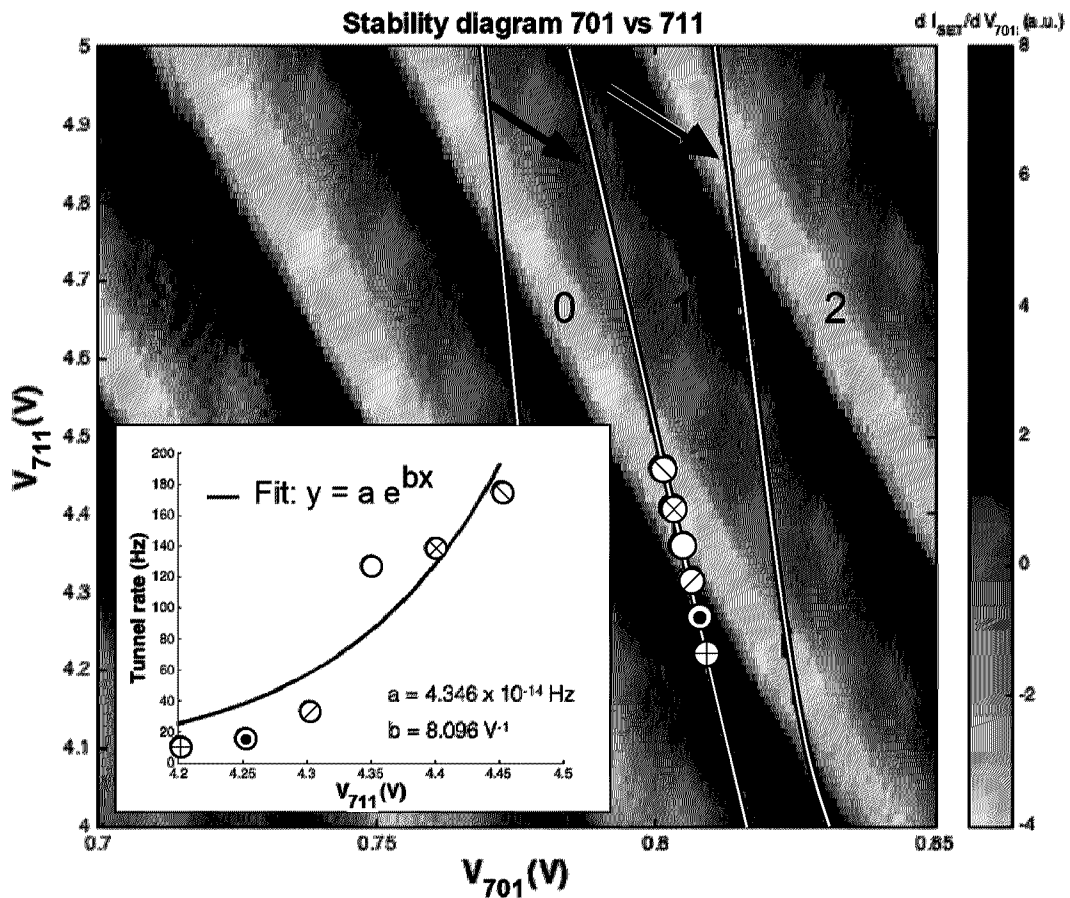
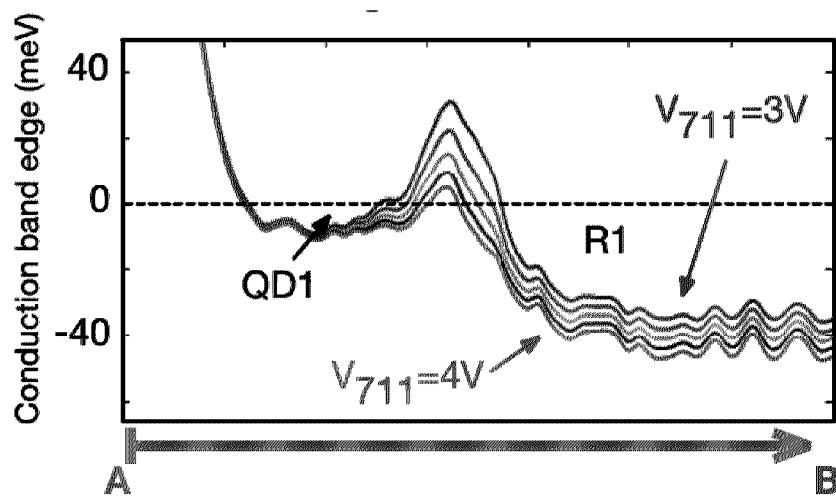
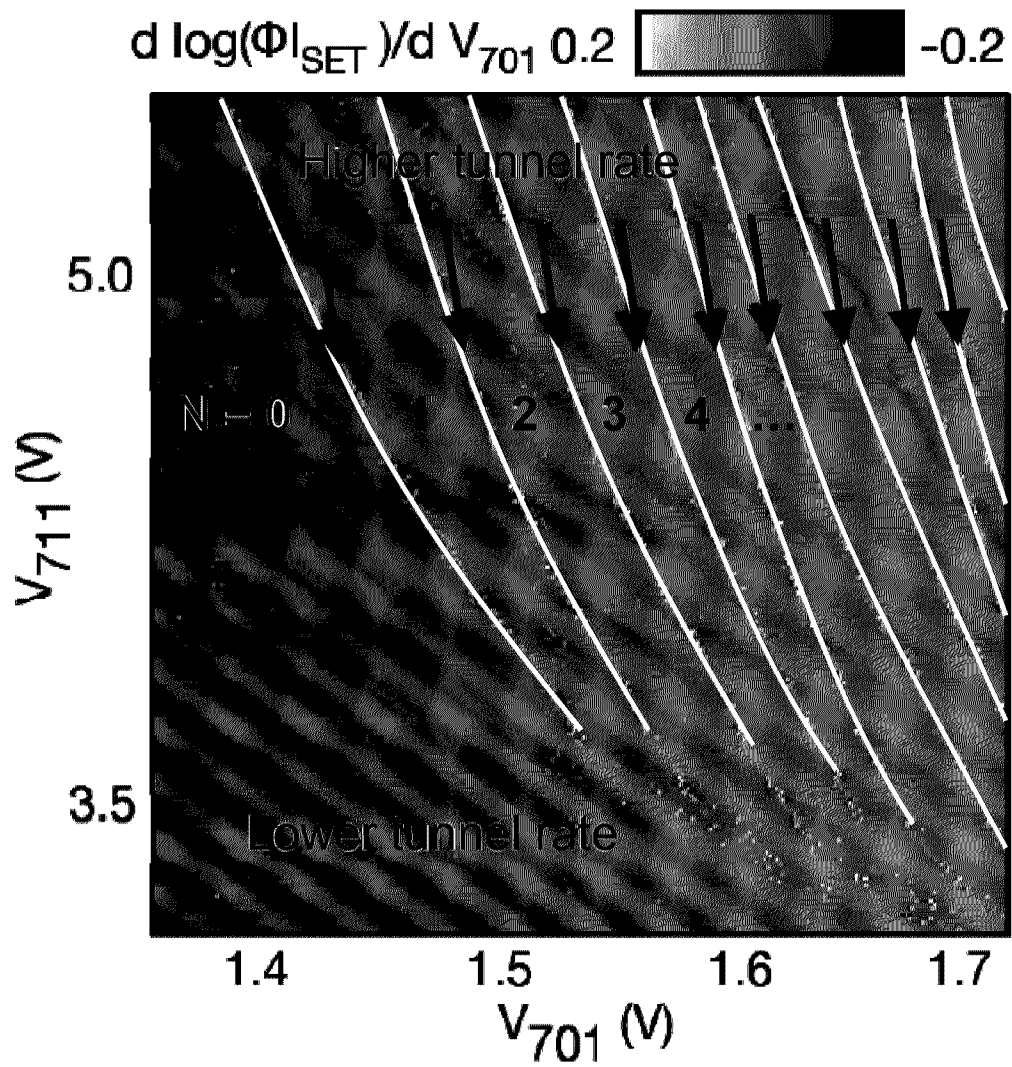

Figure 7B



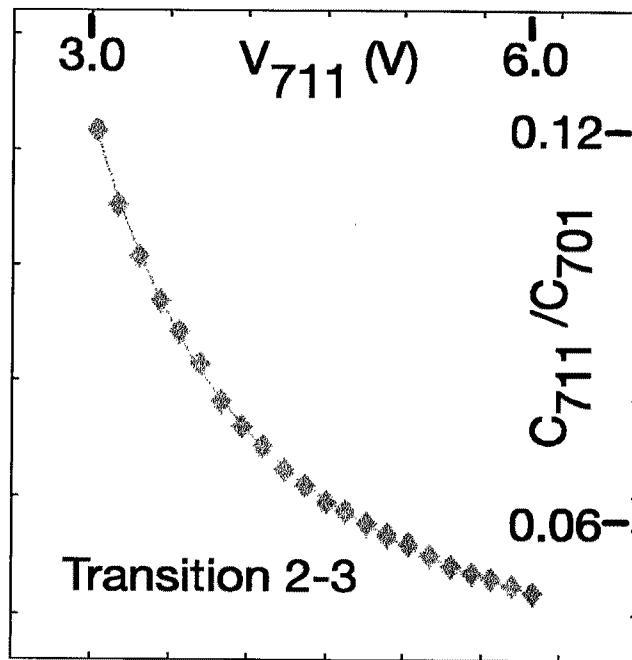

Figure 7E

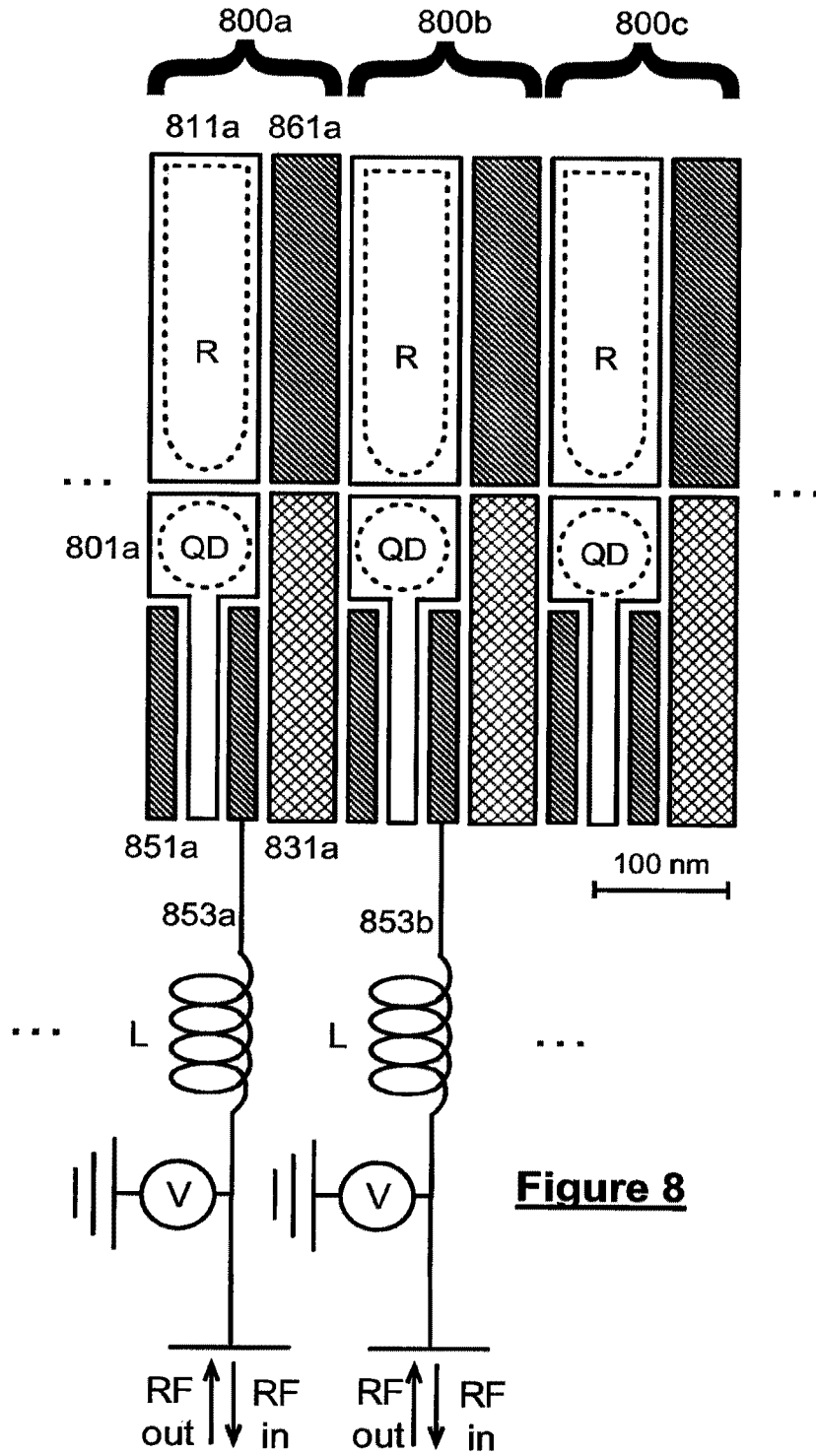

Figure 8

18/21

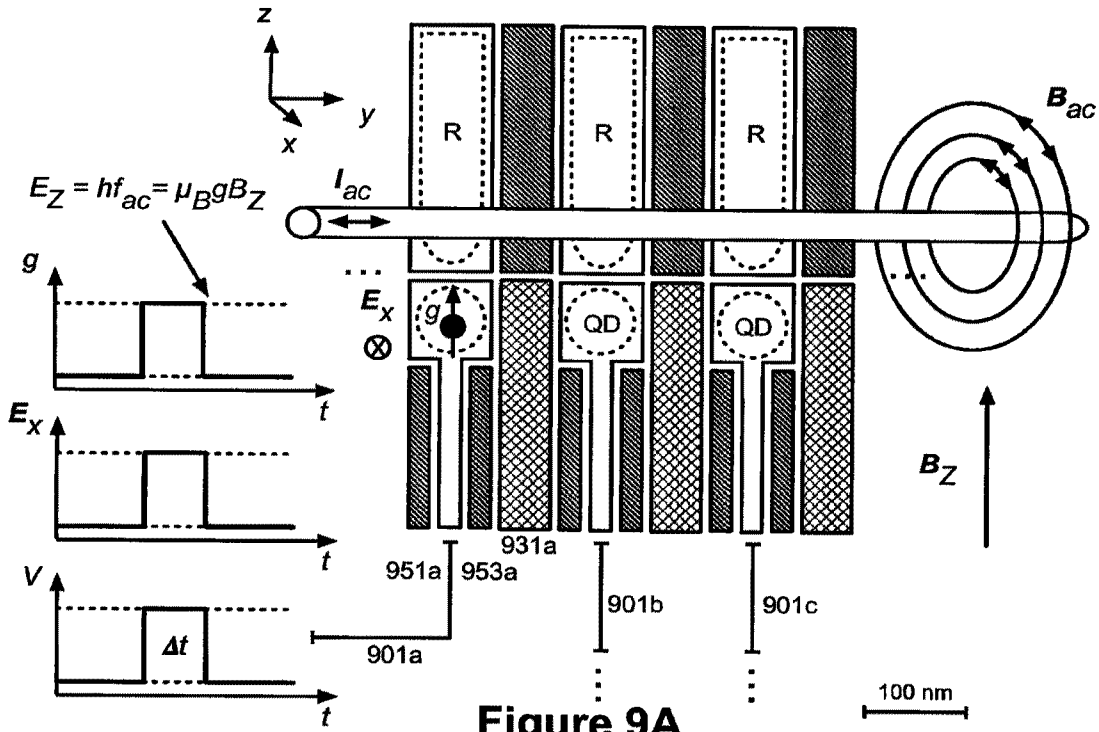

Figure 9A

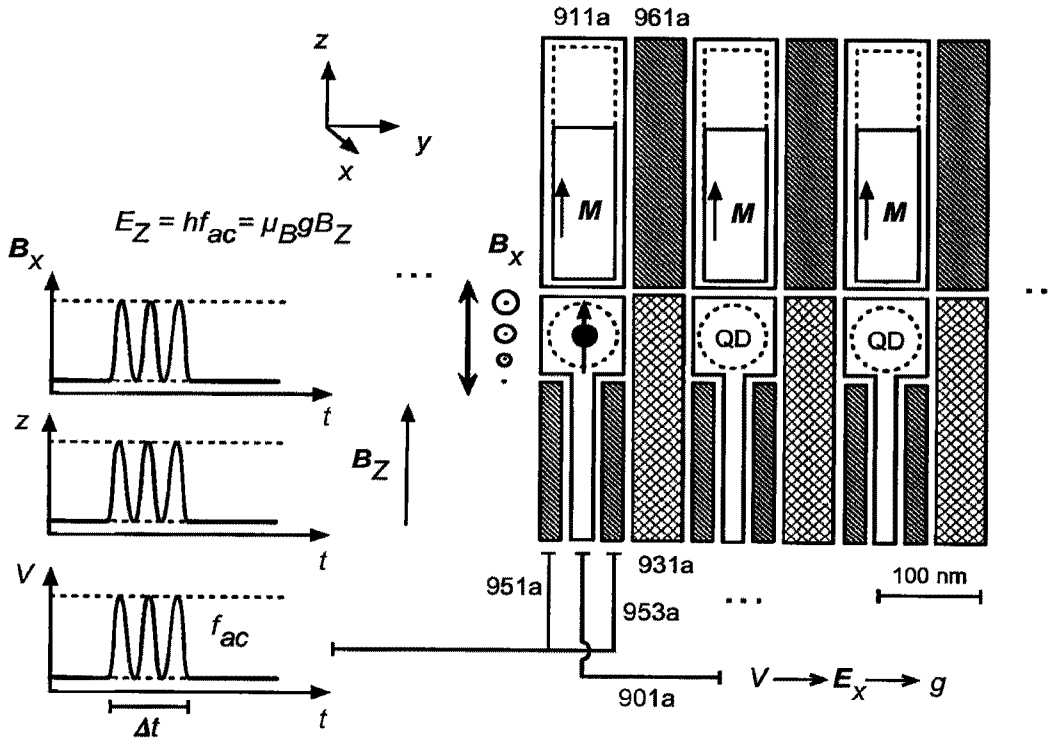

Figure 9B

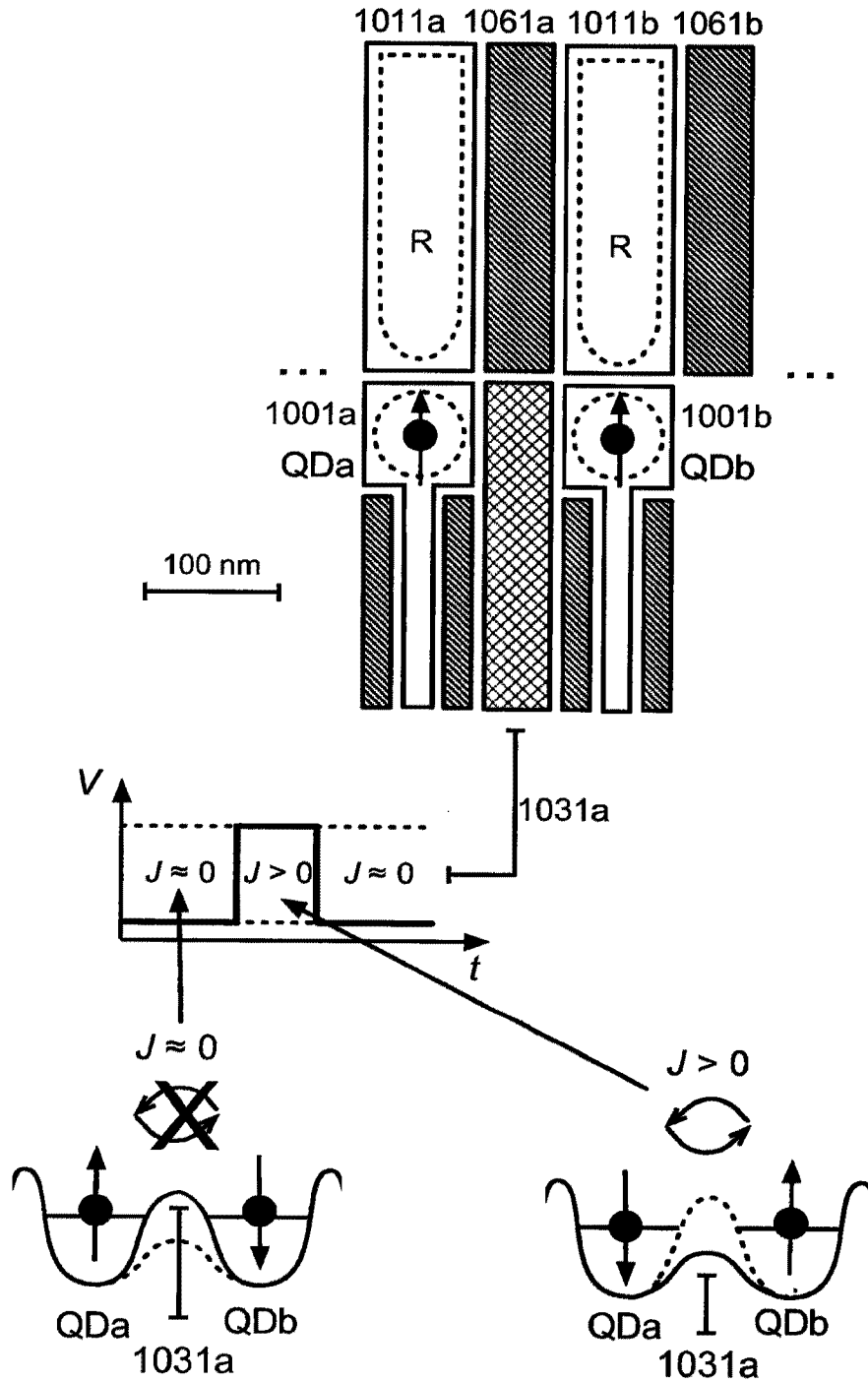

Figure 10A

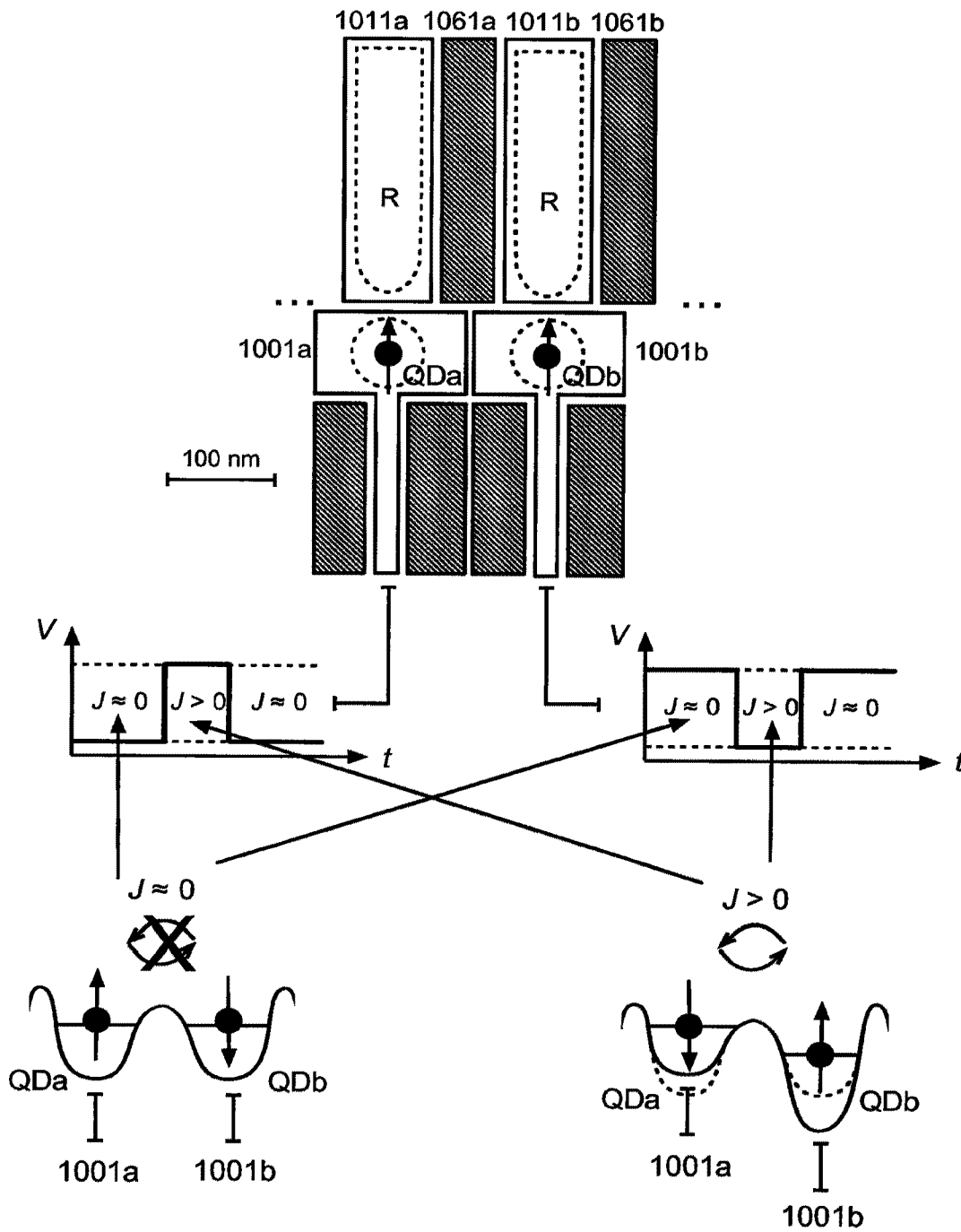

Figure 10B

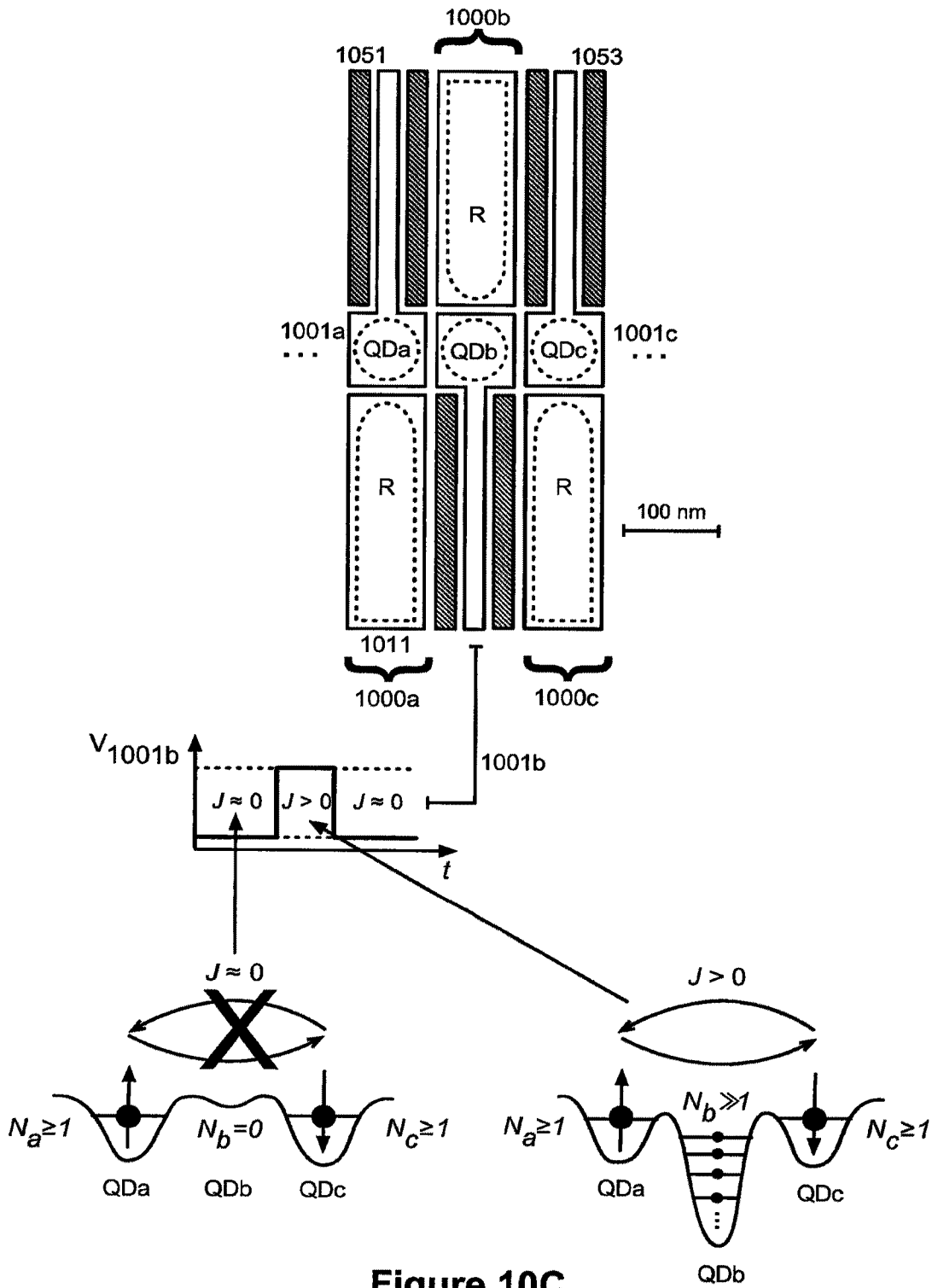

Figure 10C

511

501

