

(No Model.)

4 Sheets—Sheet 1.

H. McL. ABERNETHY.
RAILWAY SIGNAL.

No. 523,257.

Patented July 17, 1894.

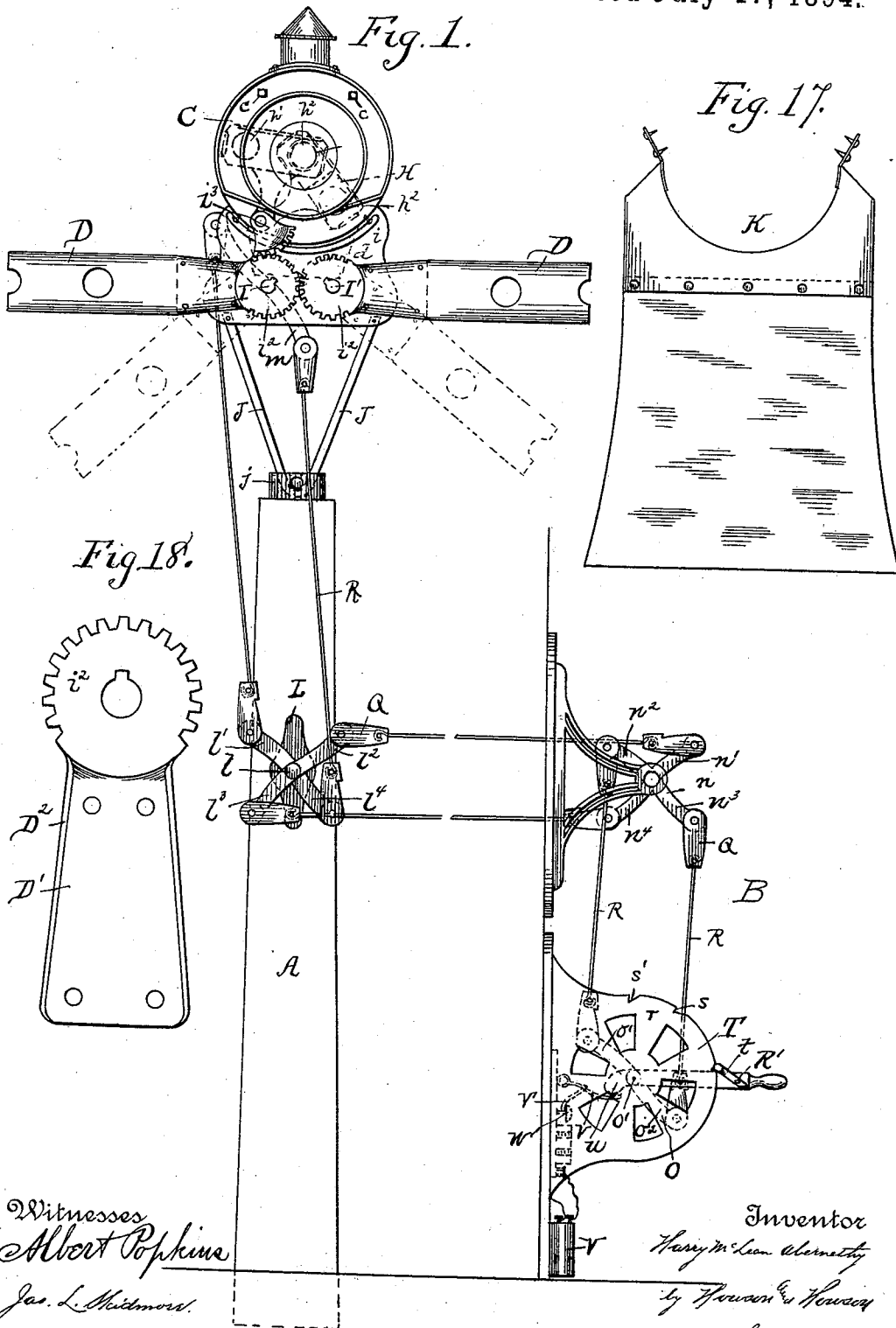

Witnesses
Albert Popkine
Jas. L. Midmore.

Inventor
Harry McL. Abernethy
by *Howden & Howden*
his Attorneys.

(No Model.)

H. McL. ABERNETHY.
RAILWAY SIGNAL.

4 Sheets—Sheet 2.

No. 523,257.

Patented July 17, 1894.

Fig. 2.

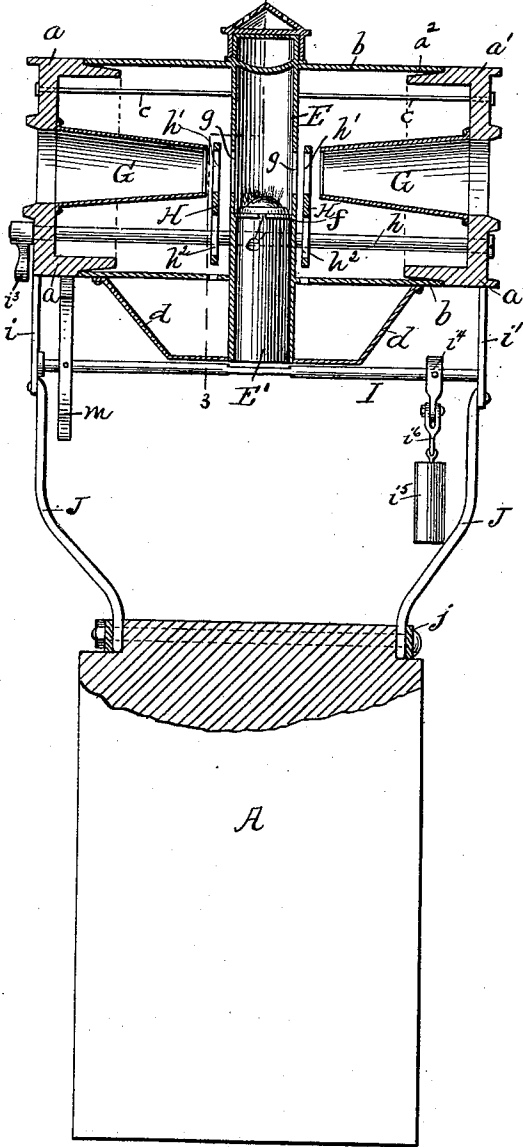
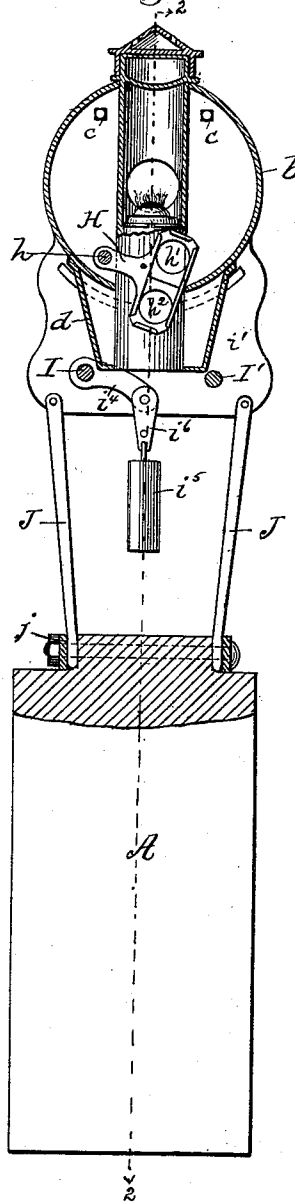

Fig. 3.



Witnesses
Albert Popkin,
Jas. L. Skidmore.

Inventor
Harry M. Leon Abernethy
by Howard E. Johnson
his Attorneys

(No Model.)

H. McL. ABERNETHY.
RAILWAY SIGNAL.

4 Sheets—Sheet 3.

No. 523,257.

Patented July 17, 1894.

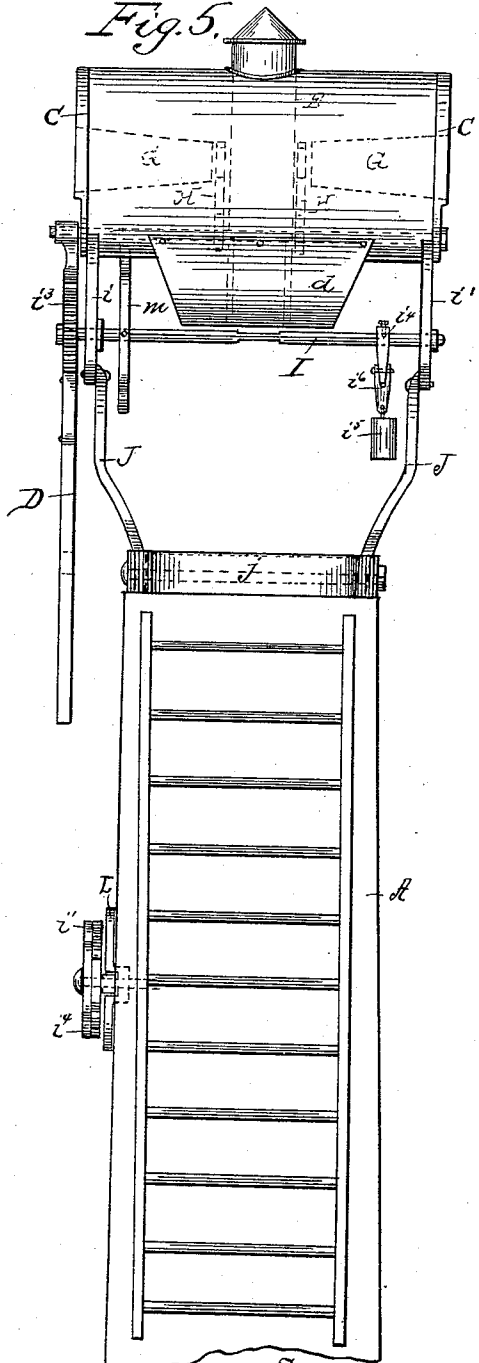
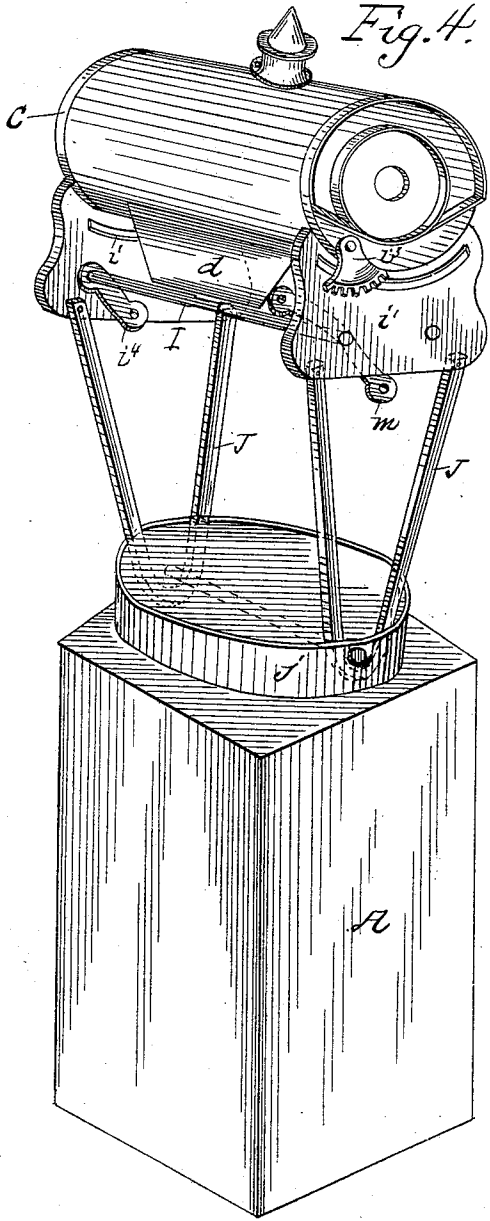

Witnesses
Albert Popkine
Jas. L. Skidmore.

Inventor
Harry McL. Abernethy
by Hanson & Hanson
 his Attorneys

H. McL. ABERNETHY.
RAILWAY SIGNAL.

No. 523,257.

Patented July 17, 1894.

Fig.13. Fig.14. Fig.15. Fig.16.

Fig.10.

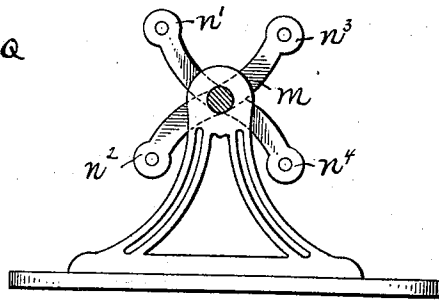
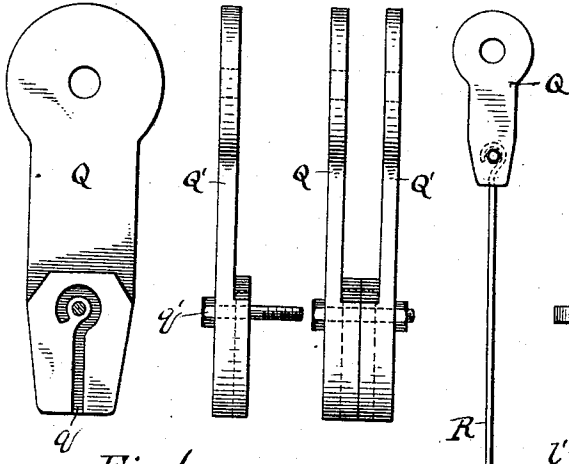

Fig.11.

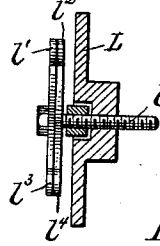

Fig.7.

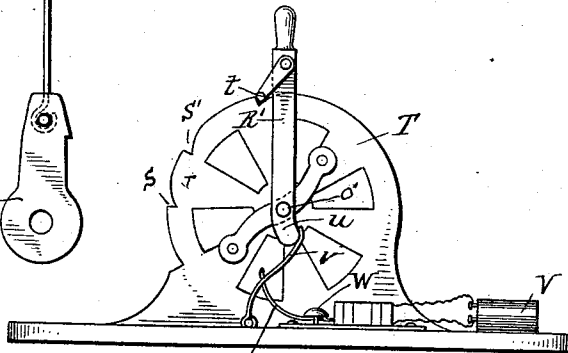

Fig.6.

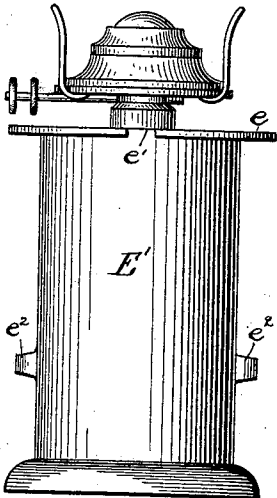

Fig.8.

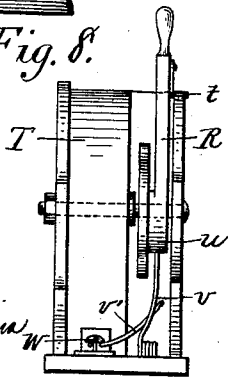

Fig.9.

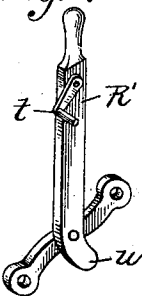
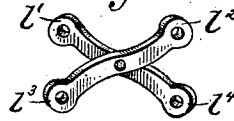

Fig.12.



Witnesses
Albert Popkin
Jas. L. Whitmore

Inventor
Harry M. Leon Abernethy
by Hanson & Hanson
 his Attorneys

UNITED STATES PATENT OFFICE.

HARRY MCLEAN ABERNETHY, OF NEWARK, OHIO.

RAILWAY-SIGNAL.

SPECIFICATION forming part of Letters Patent No. 523,257, dated July 17, 1894.

Application filed March 20, 1893. Serial No. 466,764. (No model.)

To all whom it may concern:

Be it known that I, HARRY MCLEAN ABERNETHY, a citizen of the United States, residing in the city of Newark, county of Licking, and State of Ohio, have invented certain new and useful Improvements in Railway-Signals, of which the following is a specification.

My invention relates to certain improvements in semaphore signaling devices of that general class in which a danger signal is normally displayed, and its particular object is to provide the signal with an alarm situated at any desired point and which will sound continuously when the character of the signal is changed, the alarm preferably continuing until the danger signal is displayed.

A further object of my invention is to simplify and improve the various details of construction of such a device as more fully set forth hereinafter.

In the accompanying drawings: Figure 1, is an elevation of the upper portion of a semaphore signal, also illustrating the operating devices at the tower or signal station and the connections between such tower or signal station and the semaphore. Fig. 2 is a sectional elevation on the line 2—2, Fig. 3, of the signaling lamp. Fig. 3 is a transverse section on the line 3—3, Fig. 2. Fig. 4 is a perspective view of the lamp structure. Fig. 5 is an elevation of the same. Fig. 6 is an elevation of the burner and oil receptacle of the lamp. Fig. 7 is a side elevation, partly in section, of the operating device and alarm. Fig. 8 is an end elevation of the operating devices in the tower or signal station. Fig. 9 is a perspective view of a detail of construction. Fig. 10 is an elevation, partly in section, illustrating the manner of mounting the operating levers at the signal tower. Fig. 11 is a side view of one of the operating levers, illustrating in section the means for securing the same to the signal post. Figs. 12, 13, 14, 15, 16, 17 and 18 are views of details of construction which will be referred to more specifically hereinafter.

Referring to the drawings, A represents a semaphore post of any approved construction, situated at any convenient point on the road so that the signal displayed may be readily seen by the trainmen and having its sig-

naling devices connected by suitable operating rods to a signal tower or station B.

The upper end of the post A is provided with a suitable lamp C having colored lenses so arranged as to alter the color of the lights in accordance with the alteration in position of the semaphore arms D, D, so as to provide for the display of a signal during either night or day.

Referring first to the lamp, *a, a'* represent suitable end castings provided with tapered annular flanges *a²*, over which the cylinder casing *b* of the lamp is fitted, the end sections being drawn toward each other by bolts *c* and drawing the tapered flanges *a²* within the cylindrical casing until the parts fit snugly together; immediately below this cylindrical casing is a chamber formed by a casing *d* which serves with the cylindrical casing to protect the colored lenses as they are moved out of the path of the lamp rays, and extending centrally through both casings is the cylindrical chamber E, open at its lower end and adapted to receive the lamp proper E'; the construction of the latter being more clearly shown in Fig. 6, and comprising a cylindrical body provided with an upper flange *e*, in which are cut diametrically-opposite slots *e'* and near this lower portion is provided, on lines at right angles to these slots, with lugs *e²*; the flange *e* being adapted to rest upon a shoulder *f* within the casing of the chamber D and the lugs *e²* being adapted to rest against the sides of the casing, in order to steady the lamp within the casing and prevent lateral movement of the same, the relative arrangement of the supporting devices is such that when the lamp is inserted in the lower end of the chamber E and turned part way around, its flange *e* will rest upon the lugs *f* and the lugs *e²* will extend to the casing and prevent the displacement of the lamp.

On the diametral line of the case *b* two openings *g* are made in the casing E, the openings being directly in line with converging reflectors G extending to openings formed in the heads *a, a'*, and being secured to and carried by said heads; the inner ends of the reflectors are at a sufficient distance from the casing E to provide for the ready entrance between the two of the lens frame H, which

is mounted upon a shaft h adapted to suitable bearings in the opposite end frames a, a' and which may also be provided with securing devices to take the place of one of the holding rods or bolts c .

The device as herein illustrated and described is double, so that signals may be displayed from both ends of the lamp casing, and to that end two lens frames H are provided, each carrying a red lens h^2 and a green lens h' the normal position of the lens being that illustrated by dotted lines in Fig. 1, with the red lens h^2 directly in line with the opening g in the casing E , showing a red light, while if moved to the position shown in Fig. 2, a green lens h' will be exposed, signaling caution, and if moved farther to the position shown in Fig. 3, the light is clear and indicates that the track is clear.

Immediately below the end frames a, a' , are opposite end frames i, i' , in which are formed suitable bearings for shafts I, I' , which carry the semaphore arms D , the latter being provided, as more fully set forth hereinafter, with segments i^2, i^3 , intermeshing with each other so that the movement of one will effect a corresponding movement of the other.

Intermeshing with one of the segments i^2 is a segment i^3 , mounted upon one end of the shaft h , and also mounted on the shaft I is an arm i^4 , to which is hung a weight i^5 , by means of a link i^6 , the weight being sufficient to normally keep the semaphore arms extended as shown by full lines in Fig. 1; and to keep the lens frame up with the red lens in front of the reflectors so as to display the red light.

The lamp structure as a whole is supported on top of the post A by means of suitable supporting arms J extending from the frames i, i' to the reduced upper end of the post, which is provided with a clamping collar j extending around both the rods J and the upper end of the post, and serving to securely hold the rods in position, while to protect the segments and other operating parts which might otherwise be exposed to the weather, I provide suitable shields K , having their upper ends so shaped as to fit partway around the casing and extending over and shielding the exposed parts of the mechanism.

In order to provide for the ready attachment of the semaphore arms with a view to simplify the construction, I preferably make each of the segments i^2 in a single piece with a fastening plate D' provided at its opposite edges with suitable turned-up flanges D^2 which may fit over the ends of the semaphore arms and hold the latter firmly in position, thus dispensing with the usual expensive connections commonly in use; and if desirable the counterbalancing weight may be cast in a single piece with the semaphore segment and fastening plate, thus dispensing with the counterbalancing weight i^5 on the shaft I .

At a point some distance below the top of the post A , or it may be at the extreme end of such post, is secured a plate L provided

with a projecting stud or screw bolt l , on which is mounted a lever provided with arms l', l^2, l^3, l^4 , the arms l', l^4 being connected, respectively, to the opposite ends of the levers m , keyed to the shaft I , and the opposite ends of the levers l^2 and l^3 being connected, respectively, to the ends of a lever or casting n , having four arms n', n^2, n^3, n^4 , the arms n^2 and n^3 being connected, respectively, to the arms o', o^2 , of the operating lever O , keyed to a shaft O' , mounted in suitable bearings in a supporting frame T in the signal tower or station. As shown in Figs. 1, 10, 11 and 12 the four armed lever has two of its arms in different vertical planes from the other two.

The rods which serve to connect the various arms of the levers described are of a character more clearly illustrated in Figs. 13 to 16, inclusive, and comprise opposite connecting plates Q, Q' , situated at each end of the connecting bar R , each plate being provided with an enlarged or thickened end-portion, in which is formed a slot q of a character more clearly shown in Fig. 13, and extending from the end of the plate up to and around the connecting bolt q' , which serves to hold the ends of the clamping plates in position, it being observed, however, that enough metal is left between the bolt and the slot to prevent any contact of the rod R with such bolt, and as the opposite ends of this rod are shaped to correspond to the slot, it is merely necessary to place the ends of the rods in position in the slots and clamp the two plates together by means of the bolt q' , forming a perfectly rigid and tight bar from pivot point to pivot point of the levers m , and l', l^4 , and by manufacturing the levers in a single piece, I can produce them much more rapidly and economically and, at the same time, any varying of the position which the levers might otherwise assume is avoided and the expense of fitting is lessened.

The frame T in which is mounted the shaft or bolt O' is preferably provided with a circular face r , and at s, s' this face is notched to arrest the movement of the operating lever R' , which is secured to said shaft, and is provided with a hinged pawl t adapted to engage with such recesses. The normal position of this lever is that illustrated in Fig. 1, the weight i^5 holding all of the parts as shown in said figure, with the red light exposed, the semaphore arms on the horizontal line, as shown in Fig. 1. This lever may have assumed a vertical position when the device is secured to the floor.

It will be seen that when the operator moves the lever R' up, the arrangement of levers and their connecting rods is such that by the time the pawl t arrives at the first notch, s , the semaphore arms will have assumed the position shown in dotted lines in Fig. 1, and the lens frame H will have assumed the position shown in Fig. 2, exposing a green light and signaling caution; a still further movement of the lever R' or until the pawl t engages

with the notch, s' , will cause the movement of the lens frame to the position shown in Fig. 3, exposing a clear white light, and, at the same time, the semaphore arms will have
 5 dropped to a vertical position, signaling the engineer to proceed. It is necessary, however, in changing these signals, that the operator remain at the operating lever, at all times, as in the event of his leaving it the
 10 weight w will immediately return all of the parts to the position shown in Fig. 1, displaying the danger signal, and it is in order to prevent the operator securing the operating lever at safety or caution signal that my invention particularly is made. To this end,
 15 therefore, the operating lever R' is provided with a projecting portion in the form of a toe u which passes into the path of a spring v secured to the frame-work and forming one
 20 terminal of an electric circuit which is energized by a battery V ; the opposite terminal of this circuit is formed by a looped contact-piece v' secured in any suitable manner to the frame, and so arranged that the movement
 25 of the lever R' , either to display a caution or safety signal, will immediately cause these two springs to be brought into contact, completing the circuit and energizing the magnets of an ordinary form of electric bell W ,
 30 situated either in the tower, signal station, or at any other convenient point, where due notice will be given that the operator has moved the danger position, and this alarm will continue and warn the operator, or other
 35 persons, that the signal is being held open and will, to a great extent, prevent any inattention on the part of the operator, or malicious displacement of the signal by unauthorized persons, as a continuous alarm will
 40 be given as long as the operating lever is away from its normal position.

The alarm is preferably in an electric circuit as this is the most advantageous and cheapest form, but it will be understood that
 45 any other form of alarm may be employed, such, for instance, as a clock-work or pneumatic or other power-actuated alarm, or the alarm may be made simply by the movement
 50 of the lever striking the gong, and may be continuous or intermittent, as desired.

Having thus described my invention, I claim and desire to secure by Letters Patent—

1. In a semaphore railway signal apparatus,
 55 the combination with the operating lever provided with a projecting arm, of an electric alarm bell located in a circuit having the contact points in the path of the said arm so that the circuit will be closed and the alarm
 60 sounded whenever the lever is moved from its normal position, substantially as described.

2. In a semaphore or similar signal normally displayed at danger, the combination of the signal operating device, a lever for op-

erating the same, with an alarm adapted to
 65 be brought into action by said lever when the position of such signal is changed from normal, substantially as specified.

3. The combination, in a semaphore or similar signaling device, of an operating lever
 70 adapted to control the position of such signals, and an alarm bell, an electric circuit in which said bell is placed and contact points so situated as to be operated upon by the lever
 75 to complete the circuit when such operating levers are moved from normal position, substantially as specified.

4. The combination, of the semaphore post, a lantern supported thereby, a lens frame, lenses therein adapted to be brought into the
 80 path of the light, a shaft carrying said lens frame, semaphore arms, shafts carrying the same, intermeshing segments mounted upon said shafts, a segment mounted upon the lens
 85 frame shaft and intermeshing with one of the semaphore segments, and operating levers connecting one of said semaphore shafts to an operating device, substantially as specified.

5. In a railway signal device, the covering for the lamp and lens mechanism consisting
 90 of the opposite end frames, tapered annular flanges thereon, a casing surrounding said flanges, and devices for securing the end frames together, substantially as specified.

6. In a signal apparatus the light mechanism consisting of the end frames, the reflectors carried thereby, a cylindrical casing between such end frames, a lamp, and lens
 100 frames adapted to be moved between the lamp and the inner ends of the reflectors, substantially as specified.

7. In a signal apparatus, the light mechanism comprising the end frames having reflectors secured thereto, an annular casing between said frames, a casing extending vertically
 105 through said annular casing supporting a lamp and provided with central openings on either side of said lamp, and lens frames located between the reflectors and the openings in the vertical casing, substantially as specified.
 110

8. In a railway signaling device, the combination of a signal post, frames supported thereon, a lamp carried by said frames, a shaft extending longitudinally through the casing
 115 surrounding said lamp to which is adapted a gear segment and lens frame, a shaft to which is secured the semaphore arm, and connecting devices between the semaphore and operating lever, all substantially as described.
 120

In testimony whereof I have signed my name to this specification in the presence of two subscribing witnesses.

HARRY MCLEAN ABERNETHY.

Witnesses:

ALBERT POPKINS,
 JAS. L. SKIDMORE.