

(19) World Intellectual Property Organization
International Bureau



(43) International Publication Date
24 January 2002 (24.01.2002)

PCT

(10) International Publication Number
WO 02/07341 A3

- (51) International Patent Classification⁷: H04B 7/06 Bedfordshire SG19 3AD (GB). HAINÉ, John, Leslie [GB/GB]; 9 Parkway, Shudy Camps, Cambridge CB1 6RQ (GB).
- (21) International Application Number: PCT/GB01/03185
- (22) International Filing Date: 16 July 2001 (16.07.2001) (74) Agents: HOGG, Jeffery, Keith et al.: Withers & Rogers, Goldings House, 2 Hays Lane, London SE1 2HW (GB).
- (25) Filing Language: English (81) Designated States (national): AE, AG, AL, AM, AT, AU, AZ, BA, BB, BG, BR, BY, BZ, CA, CH, CN, CO, CR, CU, CZ, DE, DK, DM, DZ, EC, EE, ES, FI, GB, GD, GE, GH, GM, HR, HU, ID, IL, IN, IS, JP, KE, KG, KP, KR, KZ, LC, LK, LR, LS, LT, LU, LV, MA, MD, MG, MK, MN, MW, MX, MZ, NO, NZ, PL, PT, RO, RU, SD, SE, SG, SI, SK, SL, TJ, TM, TR, TT, TZ, UA, UG, US, UZ, VN, YU, ZA, ZW.
- (26) Publication Language: English (84) Designated States (regional): ARIPO patent (GH, GM, KE, LS, MW, MZ, SD, SL, SZ, TZ, UG, ZW), Eurasian patent (AM, AZ, BY, KG, KZ, MD, RU, TJ, TM), European patent (AT, BE, CH, CY, DE, DK, ES, FI, FR, GB, GR, IE, IT, LU, MC, NL, PT, SE, TR), OAPI patent (BF, BJ, CF, CG, CI, CM, GA, GN, GW, ML, MR, NE, SN, TD, TG).
- (30) Priority Data:
0017427.6 14 July 2000 (14.07.2000) GB
0114031.8 8 June 2001 (08.06.2001) GB
- (71) Applicant (for all designated States except US): IP.A.C.ESS LTD. [GB/GB]; Melbourn Science Park, Cambridge Road, Royston, Herts SG8 6EE (GB).
- (72) Inventors; and
- (75) Inventors/Applicants (for US only): FOGG, Andrew [GB/GB]; 13 Middle Street, Great Gransden, Sandy.

[Continued on next page]

(54) Title: CELLULAR RADIO TELECOMMUNICATION SYSTEM

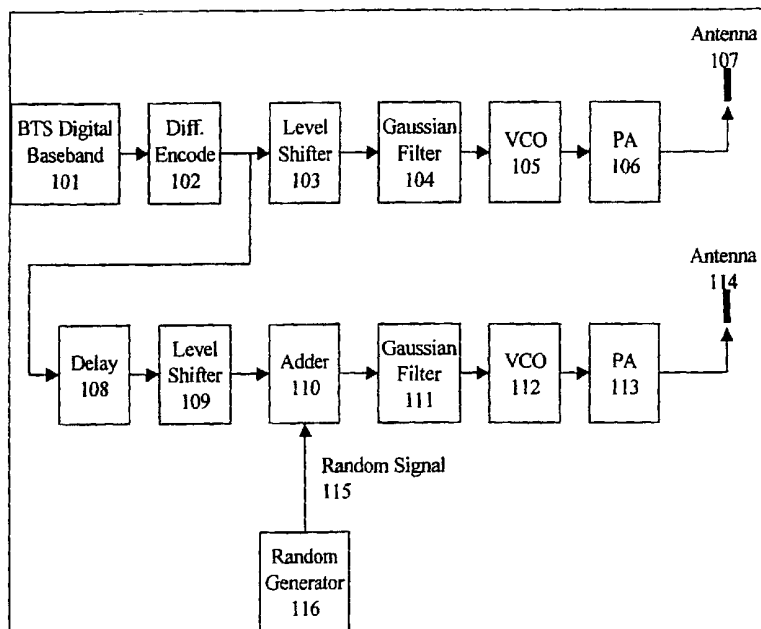

(57) Abstract: A cellular radio telecommunication system comprises a basestation having at least two antennas (107, 114). Each antenna is arranged to transmit a downlink signal to one or more mobile subscriber units. The downlink signal is transmitted from each antenna (107, 114) having a mutual time delay and phase difference, the phase difference changing from time to time. Because of the mutual phase differences, if the signals received at a mobile station are mutually in anti-phase during one time slot of the downlink signal, there is a very low probability that they will also be in anti-phase at the corresponding time slot in the next several frames.



WO 02/07341 A3



Published:

— with international search report

For two-letter codes and other abbreviations, refer to the "Guidance Notes on Codes and Abbreviations" appearing at the beginning of each regular issue of the PCT Gazette.

(88) Date of publication of the international search report:

30 May 2002

INTERNATIONAL SEARCH REPORT

International Application No

PCT/GB 01/03185

A. CLASSIFICATION OF SUBJECT MATTER IPC 7 H04B7/06				
According to International Patent Classification (IPC) or to both national classification and IPC				
B. FIELDS SEARCHED				
Minimum documentation searched (classification system followed by classification symbols) IPC 7 H04B				
Documentation searched other than minimum documentation to the extent that such documents are included in the fields searched				
Electronic data base consulted during the international search (name of data base and, where practical, search terms used) EPO-Internal, WPI Data				
C. DOCUMENTS CONSIDERED TO BE RELEVANT				
Category °	Citation of document, with indication, where appropriate, of the relevant passages	Relevant to claim No.		
X	WO 95 12927 A (NOKIA TELECOMMUNICATIONS OY ;HEIKKINEN EERO (FI); SAERKIOJA JUHA () 11 May 1995 (1995-05-11) abstract; figure 2 page 1, line 4 -page 6, line 1 claims 1,2 --- -/--	1-15		
<input checked="" type="checkbox"/> Further documents are listed in the continuation of box C.				
<input checked="" type="checkbox"/> Patent family members are listed in annex.				
° Special categories of cited documents :				
<table style="width: 100%; border: none;"> <tr> <td style="width: 50%; vertical-align: top; padding: 5px;"> *A* document defining the general state of the art which is not considered to be of particular relevance *E* earlier document but published on or after the international filing date *L* document which may throw doubts on priority claim(s) or which is cited to establish the publication date of another citation or other special reason (as specified) *O* document referring to an oral disclosure, use, exhibition or other means *P* document published prior to the international filing date but later than the priority date claimed </td> <td style="width: 50%; vertical-align: top; padding: 5px;"> *T* later document published after the international filing date or priority date and not in conflict with the application but cited to understand the principle or theory underlying the invention *X* document of particular relevance; the claimed invention cannot be considered novel or cannot be considered to involve an inventive step when the document is taken alone *Y* document of particular relevance; the claimed invention cannot be considered to involve an inventive step when the document is combined with one or more other such documents, such combination being obvious to a person skilled in the art. *&* document member of the same patent family </td> </tr> </table>			*A* document defining the general state of the art which is not considered to be of particular relevance *E* earlier document but published on or after the international filing date *L* document which may throw doubts on priority claim(s) or which is cited to establish the publication date of another citation or other special reason (as specified) *O* document referring to an oral disclosure, use, exhibition or other means *P* document published prior to the international filing date but later than the priority date claimed	*T* later document published after the international filing date or priority date and not in conflict with the application but cited to understand the principle or theory underlying the invention *X* document of particular relevance; the claimed invention cannot be considered novel or cannot be considered to involve an inventive step when the document is taken alone *Y* document of particular relevance; the claimed invention cannot be considered to involve an inventive step when the document is combined with one or more other such documents, such combination being obvious to a person skilled in the art. *&* document member of the same patent family
A document defining the general state of the art which is not considered to be of particular relevance *E* earlier document but published on or after the international filing date *L* document which may throw doubts on priority claim(s) or which is cited to establish the publication date of another citation or other special reason (as specified) *O* document referring to an oral disclosure, use, exhibition or other means *P* document published prior to the international filing date but later than the priority date claimed	*T* later document published after the international filing date or priority date and not in conflict with the application but cited to understand the principle or theory underlying the invention *X* document of particular relevance; the claimed invention cannot be considered novel or cannot be considered to involve an inventive step when the document is taken alone *Y* document of particular relevance; the claimed invention cannot be considered to involve an inventive step when the document is combined with one or more other such documents, such combination being obvious to a person skilled in the art. *&* document member of the same patent family			
Date of the actual completion of the international search <p style="text-align: center;">7 January 2002</p>		Date of mailing of the international search report <p style="text-align: center;">14/01/2002</p>		
Name and mailing address of the ISA European Patent Office, P.B. 5818 Patentlaan 2 NL - 2280 HV Rijswijk Tel. (+31-70) 340-2040, Tx. 31 651 epo nl, Fax: (+31-70) 340-3016		Authorized officer <p style="text-align: center;">Katruff, M</p>		

INTERNATIONAL SEARCH REPORT

International Application No
PCT/GB 01/03185

C.(Continuation) DOCUMENTS CONSIDERED TO BE RELEVANT		
Category °	Citation of document, with indication, where appropriate, of the relevant passages	Relevant to claim No.
X	MOGENSEN P E: "GSM BASE-STATION ANTENNA DIVERSITY USING SOFT DECISION COMBINING ON UP-LINK AND DELAYED-SIGNAL TRANSMISSION ON DOWN-LINK" PERSONAL COMMUNICATION - FREEDOM THROUGH WIRELESS TECHNOLOGY. SECAUCUS, NJ., MAY 18 - 20, 1993, PROCEEDINGS OF THE VEHICULAR TECHNOLOGY CONFERENCE, NEW YORK, IEEE, US, vol. CONF. 43, 18 May 1993 (1993-05-18), pages 611-616, XP000393257 ISBN: 0-7803-1267-8	1,5-9
Y	abstract; figure 1 page 613, right-hand column, last paragraph -page 614, right-hand column, paragraph 2	2-4, 11-15
X	VIJITHA WEERACKODY: "CHARACTERISTICS OF A SIMULATED FAST FADING INDOOR RADIO CHANNEL" PERSONAL COMMUNICATION - FREEDOM THROUGH WIRELESS TECHNOLOGY. SECAUCUS, NJ., MAY 18 - 20, 1993, PROCEEDINGS OF THE VEHICULAR TECHNOLOGY CONFERENCE, NEW YORK, IEEE, US, vol. CONF. 43, 18 May 1993 (1993-05-18), pages 231-235, XP000393165 ISBN: 0-7803-1267-8	1,5-10
Y	abstract page 231, left-hand column, paragraph 2 -right-hand column, last paragraph	2-4, 11-15
X	US 6 034 987 A (DENT PAUL WILKINSON ET AL) 7 March 2000 (2000-03-07) abstract; figure 2 column 5, line 5 - line 25 column 5, line 50 -column 6, line 5	1,5,6,9

INTERNATIONAL SEARCH REPORT

Information on patent family members

International Application No

PCT/GB 01/03185

Patent document cited in search report	Publication date	Patent family member(s)	Publication date
WO 9512927 A	11-05-1995	FI 934875 A	05-05-1995
		AU 8062894 A	23-05-1995
		WO 9512927 A1	11-05-1995

US 6034987 A	07-03-2000	AU 5521098 A	15-07-1998
		BR 9713943 A	21-03-2000
		CN 1245600 A	23-02-2000
		EP 0947058 A2	06-10-1999
		JP 2001524277 T	27-11-2001
		WO 9827663 A2	25-06-1998
		US 5991331 A	23-11-1999
