

(19) World Intellectual Property Organization
International Bureau



(43) International Publication Date
16 November 2006 (16.11.2006)

PCT

(10) International Publication Number
WO 2006/121969 A1

(51) International Patent Classification:

A61M 31/00 (2006.01) A61F 6/14 (2006.01)
A61M 25/00 (2006.01) A61L 29/00 (2006.01)

(21) International Application Number:

PCT/US2006/017618

(22) International Filing Date: 8 May 2006 (08.05.2006)

(25) Filing Language: English

(26) Publication Language: English

(30) Priority Data:

11/125,296 9 May 2005 (09.05.2005) US

(71) Applicant (for all designated States except US): **BOSTON SCIENTIFIC SCIMED, INC.** [US/US]; One Scimed Place, Mapled Grove, Minnesota 55311 (US).

(72) Inventors; and

(75) Inventors/Applicants (for US only): **MCINTYRE, Jon T.** [US/US]; 429 Waltham Street, Newton, Massachusetts 02465 (US). **DAIGNAULT, Kenneth** [US/US]; 50 Winfield Road, Holden, Massachusetts 01520 (US).

(74) Agents: **PARK, Keum J** et al.; **MAYER & WILLIAMS PC**, 251 North Avenue West, 2nd Floor, Westfield, New Jersey 07090 (US).

(81) Designated States (unless otherwise indicated, for every kind of national protection available): AE, AG, AL, AM, AT, AU, AZ, BA, BB, BG, BR, BW, BY, BZ, CA, CH, CN, CO, CR, CU, CZ, DE, DK, DM, DZ, EC, EE, EG, ES, FI, GB, GD, GE, GH, GM, HR, HU, ID, IL, IN, IS, JP, KE, KG, KM, KN, KP, KR, KZ, LC, LK, LR, LS, LT, LU, LV, LY, MA, MD, MG, MK, MN, MW, MX, MZ, NA, NG, NI, NO, NZ, OM, PG, PH, PL, PT, RO, RU, SC, SD, SE, SG, SK, SL, SM, SY, TJ, TM, TN, TR, TT, TZ, UA, UG, US, UZ, VC, VN, YU, ZA, ZM, ZW.

(84) Designated States (unless otherwise indicated, for every kind of regional protection available): ARIPO (BW, GH, GM, KE, LS, MW, MZ, NA, SD, SL, SZ, TZ, UG, ZM, ZW), Eurasian (AM, AZ, BY, KG, KZ, MD, RU, TJ, TM), European (AT, BE, BG, CH, CY, CZ, DE, DK, EE, ES, FI, FR, GB, GR, HU, IE, IS, IT, LT, LU, LV, MC, NL, PL, PT, RO, SE, SI, SK, TR), OAPI (BF, BJ, CF, CG, CI, CM, GA, GN, GQ, GW, ML, MR, NE, SN, TD, TG).

Published:

- with international search report
- before the expiration of the time limit for amending the claims and to be republished in the event of receipt of amendments

For two-letter codes and other abbreviations, refer to the "Guidance Notes on Codes and Abbreviations" appearing at the beginning of each regular issue of the PCT Gazette.

(54) Title: MEDICAL DEVICES FOR TREATING UROLOGICAL AND UTERINE CONDITIONS

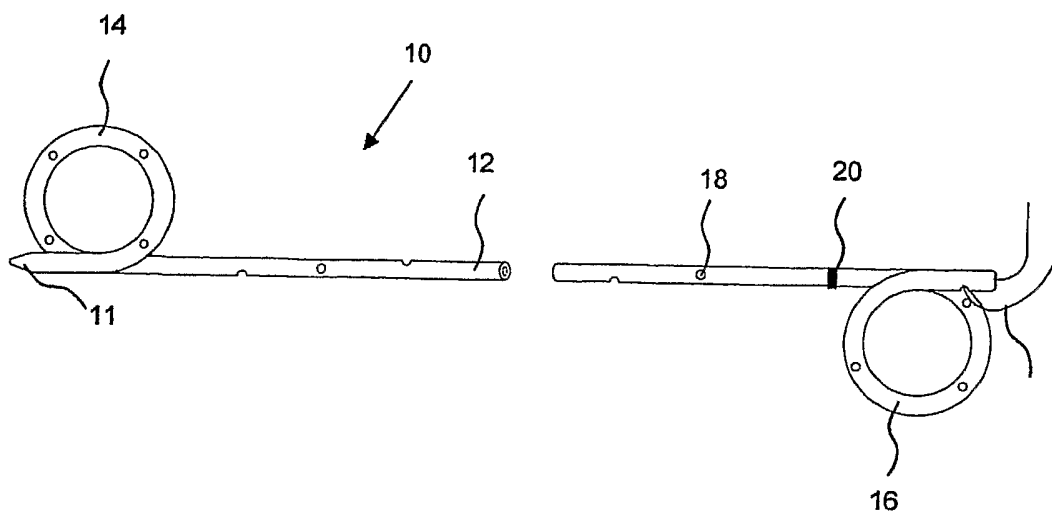

(57) Abstract: The present application, relates to implantable or insertable medical devices (10) that treat uterine and urological conditions that cause chronic pelvic pain and other symptoms. In another aspect, the present application relates to methods of manufacturing such implantable or insertable medical devices .

WO 2006/121969 A1

MEDICAL DEVICES FOR TREATING
UROLOGICAL AND UTERINE CONDITIONS

CROSS REFERENCE TO RELATED APPLICATIONS

[0001] This application is related to U.S. Patent Application Serial No. 11/125,297, filed on May 9, 2005, and entitled "Injectable Bulking Compositions," which is incorporated by reference in its entirety herein.

[0002] This application is related to U.S. Patent Application Serial No. 11/124,827, filed on May 9, 2005, and entitled "Method and Device For Tissue Removal And For Delivery Of A Therapeutic Agent Or Bulking Agent," which is incorporated by reference in its entirety herein.

[0003] This application is related to U.S. Patent Application Serial No. 11/124,828, filed on May 9, 2005, and entitled "Method For Treatment of Uterine Fibroid Tumors," which is incorporated by reference in its entirety herein.

FIELD OF THE INVENTION

[0004] The present invention relates generally to medical devices which contain polymer regions for release of therapeutic agents. In particular, the present invention relates to implantable or insertable medical devices that treat pelvic pain caused by gynecological and urological conditions such as uterine fibroids, endometriosis, interstitial cystitis, and urethral syndrome, as well as methods for manufacturing such devices.

BACKGROUND OF THE INVENTION

[0005] Interstitial cystitis ("IC") is a chronic progressive disorder of the lower urinary tract affecting both men and women marked by an inflammation or irritation of the bladder leading to urinary urgency, frequency and/or tenderness or pain in the bladder and surrounding pelvic area. Recent studies have indicated that up to 80-85% of women of the approximately nine million women who suffer from chronic pelvic pain may have interstitial cystitis (*see* Parsons et al., "Gynecologic presentation of interstitial cystitis as detected by intravesical potassium sensitivity," *Obstet Gynecol*, 98(1):127-132 (2001);

Parsons et al., "The prevalence of interstitial cystitis in gynecologic patient with pelvic pain as detected by intravesical potassium sensitivity," *Am J Obstet Gynecol*, 187(5):1395-1400 (2002), the contents of both of which are incorporated by reference in their entirety).

[0006] Though its etiology is unknown, it is believed that the protective layer of glycosaminoglycans (GAG) that protects the inner epithelial lining of the bladder is somehow disrupted, allowing substances in the urine to irritate the underlying epithelial cells. This disruption in the GAG lining is believed to be caused by an unidentified infection, perhaps of viral origin, that is disrupting the GAG lining or damaging the bladder wall directly, by a substance in the urine that causes the damage, and/or by an autoimmune response following a bladder infection.

[0007] Urethral syndrome is a related painful voiding disorder of unknown etiology affecting women exhibiting many similar symptoms set forth above.

[0008] Unlike some other diseases of the genitourinary system, such as common cystitis, urethritis, and nephritis, and bacterial prostatitis, IC and urethral syndrome generally do not respond to antibiotic therapy. For most IC patients, and for patients with prostatodynia, a related condition that occurs in men, therapy includes heparinoid therapy with oral pentosan polysulfate (PPS; Elmiron®, Ortho-McNeil/Alza), typically 300-600 mg daily, intravesical heparin (40,000 units in 8ml of 1% lidocaine and 3 ml sodium bicarbonate once or twice daily), or both. This therapy is usually combined with oral pain medication, antidepressants (to reverse neural activation of bladder nerves that may cause symptoms of pain and urgency to persist even after the epithelium has been restored), and/or antihistamines (to control immune system mast cell degranulation that is believed to provoke IC symptom flares). Heparinoids are similar in structure to the glycosaminoglycans in the bladder surface mucus and are believed to help repair or restore the epithelium in individuals who have abnormal epithelial permeability.

[0009] Other therapy options includes bladder instillation wherein the bladder is temporarily filled with a solution containing a therapeutic agent such as dimethyl sulfoxide (DMSO), transcutaneous electrical nerve stimulation (TENS), which delivers mild electric pulses to the bladder area, and as a last resort, bladder surgery.

[0010] Despite these treatment options, there is a continuing need for alternative therapies

that provide relief from IC symptoms, urethral syndrome and other urological symptoms and/or treat the underlying conditions that trigger these symptoms or prevent them from occurring.

[0011] Other leading causes of chronic pelvic pain are uterine fibroids and endometriosis. These two medical conditions affect millions of women in the U.S. and cost billions of dollars in health care dollars each year. Uterine fibroid tumors (also referred to as “uterine fibroids” or “leiomyomas”) are non-cancerous smooth muscle tumors of the uterus. They are believed to occur in 20 percent to 50 percent of women, depending on age and race. Depending on their size and location, fibroids can cause a variety of symptoms, the most common of which are bleeding and “bulk” pelvic pain, and infertility. Some of the most common treatments for fibroids are quite invasive. For example, although a hysterectomy results in the complete removal of the uterus, approximately one-third of the hysterectomies in the United States each year are performed to treat uterine fibroids. Myomectomy is also commonly used to surgically remove uterine fibroids. However, about three-quarters of the myomectomy surgeries are open surgeries involving an abdominal incision. A more recently developed treatment is uterine artery embolization. During this procedure, a catheter is inserted into a femoral artery and guided to a uterine fibroid artery. Small particles are then injected from the catheter into the fibroid artery, blocking its blood supply and causing it to eventually shrink and die. Although this procedure is less invasive than the above procedures, it commonly results in pain-related post-surgical symptoms. Myolysis and cryomyolysis are other techniques in which uterine fibroids are burned or frozen via laproscopic surgery. Like uterine artery embolization, myolysis/cryomyolysis causes fibroids to die and shrink over time.

[0012] Endometriosis, although a separate disease, is believed to be often triggered by the same mechanisms that cause fibroids and can also significantly impact a woman’s quality of life. Endometriosis is a condition where the endometrium (the lining of the uterus) is found in locations outside the uterus. This misplaced tissue may be found, for example, on the ovaries, outer wall of the uterus, bowel, bladder, utero-sacral ligaments (ligaments that hold the uterus in place) or peritoneum. On rare occasions, they may be found in distant sites such as the lungs or an armpit. As with fibroids, typical treatments include surgery to remove endometrial plaques by mechanical, electrical or laser means, and hysterectomy.

[0013] Non-surgical treatment options for both fibroids and endometriosis include oral administration of pain medication and hormonal therapy. For example, in the case of endometriosis, drug therapy includes non-steroidal anti-inflammatory drugs (NSAIDS) and hormonal therapy to interrupt ovarian function and control menstrual bleeding with hormones such as oral contraceptives, progestins, danazol, GnRH agonists, Mifepristone, selective progesterone receptor modulators (SPRMs) or aromatase inhibitors. Similarly, drug therapy for fibroids includes NSAIDS, oral contraceptives, and GnRH agonists.

[0014] For a significant fraction of patients, however, drug therapy, on its own, provides insufficient relief from symptoms caused by the fibroids and/or endometriosis and necessitates subsequent treatment with one of the surgical options discussed above. In addition, since the drugs are administered orally (i.e., systemically) and not directly to the fibroids or the endometrial cysts, the doses of drugs, particularly of hormonal drugs, required to disrupt ovarian function, menstrual bleeding, and/or cause fibroid shrinkage are high enough to cause undesirable side effects.

[0015] Hence, there is a continuing need for alternative therapies for the treatment of uterine fibroids and endometriosis, which are less invasive, which provide better relief from pelvic pain and discomfort, which preserve the patient's uterus, and which cause fewer side effects.

SUMMARY OF THE INVENTION

[0016] In an effort to alleviate the foregoing and other disadvantages of the prior art, Applicants have developed implantable or insertable medical devices suitable for short-term to long-term placement and/or implantation and a method for manufacturing such devices, wherein the devices provide *in situ* treatment of various uterine or urological conditions by delivering therapeutic agent(s) particularly suited for treating these conditions.

BRIEF DESCRIPTION OF THE DRAWINGS

[0017] Fig. 1 is a simplified schematic representation of a urological device, specifically a ureteral stent, according to one embodiment of the present invention.

[0018] Fig. 2 shows the ureteral stent of Fig. 1 as positioned within the body using a

standard catheter means. The stent is placed within the human urinary tract, which includes the renal pelvis, the kidney, the ureter, the urethra and the ureteral orifices opening into the bladder.

[0019] Fig. 3A is a schematic representation of a uterine device according to one embodiment of the present invention.

[0020] Fig. 3B is a cut-away schematic cross-sectional view of a device like that of Fig. 3A, withdrawn within a section of a delivery sheath.

[0021] Fig. 4 is a simplified schematic representation of a uterine device like that of Fig. 3A, positioned within the uterus.

DETAILED DESCRIPTION OF THE PREFERRED EMBODIMENTS

[0022] The present invention is directed to urological and uterine devices for treating one or more of the diseases and/or conditions set forth above. As used herein, "treatment" refers to the prevention of a disease or condition, the reduction or elimination of symptoms associated with a disease or condition, or the substantial or complete elimination of a disease or condition. Preferred subjects (also referred to as "patients") are mammalian subjects, and more preferably are human subjects.

[0023] As noted above, the implantable or insertable medical devices of the present invention are suitable for short-term to long-term placement and/or implantation, meaning times ranging from 24 hours to 2 days to 4 days to 1 week to 2 weeks to 1 month to 3 months to 6 months to 12 months or even longer.

[0024] According to one aspect of the present invention, a urological medical device is provided comprising a first therapeutic agent for treating a urological condition, wherein the medical device is adapted, upon implantation or insertion into a patient, to release all or a majority of a first therapeutic agent from a portion of the medical device that occupies the urinary bladder. The urological condition may comprise any condition affecting the urinary tract such as common cystitis, urethritis, and nephritis, and bacterial prostatitis, IC and urethral syndrome, but particularly to those that affect the bladder, such as interstitial cystitis.

[0025] According to one embodiment of this aspect of the invention, a urological medical

device is provided which resides partially in the urinary bladder and which extends upstream from the bladder, downstream from the bladder, or both. For example, the device can be a urethral stent which includes a tubular member having a bladder retention feature at the distal end of the tubular member, or a ureteral stent, which includes a tubular member, a renal retention feature at the distal end of the tubular member and a bladder retention feature at the proximal end of the tubular member. The portion of such a medical device that resides in the bladder (the "bladder portion") contains at least one release region that in turn controls the release of at least one therapeutic agent (which is disposed beneath or within the release region) for treating a urological condition. Moreover, in some embodiments, the therapeutic agent is either present exclusively in the bladder portion of the device, or is released from the bladder portion in concentrations that are greater (e.g., 1.5 times or more, 2 times or more, 3 times or more, 4 times or more, 5 times or more, 10 times or more, 25 times or more, 50 times or more, 100 times or more greater) than the concentrations released from other portions of the device. This can be achieved, for example, by providing concentrations of therapeutic agent in the bladder portion that are greater (e.g., by the above amounts) than the concentrations found in other portions of the device.

[0026] According to yet another embodiment of this aspect of the present invention, a urological medical device is provided where the therapeutic agent is released only from the portion of the medical device that occupies the urinary bladder. In other embodiments, the device resides completely in the urinary bladder.

[0027] The release regions of the above urological devices contain one or more polymers that may be selected from any biocompatible polymers that are suitable for use in implantable or insertable urological medical devices and are suitable for therapeutic agent release. (As used herein, the term "biocompatible" describes a material that is substantially not toxic to the human body, and that does not significantly induce inflammation or other adverse response in body tissues.)

[0028] The polymers may be substantially non-biodegradable or biodegradable. In other embodiments, the device comprises a second therapeutic agent, or a plurality of therapeutic agents. Typically, the therapeutic agent is disposed beneath or within at least one release region that comprises a biocompatible polymer. The release region can comprise one, two, or a plurality of biocompatible polymers.

[0029] An advantage of the urological devices of the present invention is that since the therapeutic agents are released from the devices *in situ*, e.g., near or inside the bladder, treatment is more direct, and less medication may be required as compared with typical systemic treatments such as oral pentosan polysulfate, antidepressant or antihistamine therapy.

[0030] Another advantage of certain urological devices of the present invention is that they may be selected for use in patients already requiring a stent or other device for another urological condition, such as a ureteral blockage or obstruction. The therapeutic agent(s) that are released from the device may treat the other condition (e.g., that caused by the blockage or obstruction) and/or treat other conditions such as interstitial cystitis.

[0031] According to another aspect of the present invention, a uterine device is provided, which is adapted to conform to the general contours of an interior cavity of a mammalian female uterus. According to one embodiment of this aspect, the invention comprises a uterine device for the treatment of a uterine condition comprising a contoured structure of a flexible material having the general contours of an interior cavity of a human female uterus wherein the device comprises a therapeutic agent for treating a uterine condition. The device comprises at least one release region that controls the release of at least one therapeutic agent (which is disposed beneath or within the release region) for treating a uterine condition.

[0032] At least one release region also contains at least one polymer that may be selected from any biocompatible polymers that are suitable for use in implantable or insertable uterine medical devices and are suitable for therapeutic agent release. The polymers may be substantially non-biodegradable or biodegradable and a device may comprise a plurality of biocompatible polymers.

[0033] An advantage of the uterine devices of the present invention is that since the therapeutic agent is released from the devices *in situ*, treatment is more direct, and less medication may be required as compared with typical systemic treatments such as oral contraceptives that may cause undesirable side effects. In particular, given that the devices are shaped to generally conform to the contours of the uterine cavity (e.g., the device comes into contact with the walls of the uterine cavity), an appreciable percentage of a surface of the device comes into contact with the uterine wall, facilitating direct and targeted release of the therapeutic agent into the uterine site.

[0034] Another advantage of the uterine devices of the present invention is that therapy using such devices is less invasive than surgical treatment options such as hysterectomy and myolysis.

[0035] Another advantage of the uterine device of the present invention is that since the device may be easily removed and replaced, the type or amount of therapeutic agent may be adjusted accordingly during the duration of the treatment, e.g., a succession of different hormonal agents and/or different agent concentrations may be employed to coincide with the patient's menstrual cycle.

[0036] The release regions of the present invention form at least a portion of the implantable or insertable medical devices of the present invention, and in some instances form the entire medical devices, in which case the materials forming the release region are selected to provide mechanical properties consistent with the intended function and operation of the implantable or insertable medical devices. A device may have a plurality of release regions. The base polymer can also be biodegradable to eliminate the need for removal.

[0037] Release regions for use in accordance with the devices of the present invention include carrier regions and barrier regions. By "carrier region" is meant a release region which further comprises a therapeutic agent and from which the therapeutic agent is released. Hence, in these embodiments, the release regions serve as a repository in which at least one therapeutic agent is present (e.g., dispersed and/or dissolved). For example, in some embodiments, a carrier region is disposed over all or a portion of a medical device substrate. In other embodiments, a carrier region constitutes the entirety of the medical device. In other embodiments, the medical device will comprise two or more distinct carrier regions, which may exist, e.g., as coaxial layers or as distinct sections lengthwise along the longitudinal axis of the device (e.g., a stent having distinct end regions of different durometer value and/or different therapeutic agent content with a transitional coextruded region in between).

[0038] By "barrier region" is meant a region which is disposed between a source of therapeutic agent and a site of intended release, and which controls the rate at which therapeutic agent is released. For example, in some embodiments, the medical device is provided with a barrier region that surrounds a source of therapeutic agent. In other

embodiments, a barrier region is disposed over a source of therapeutic agent, which is in turn disposed over all or a portion of a medical device substrate.

[0039] Hence, in certain embodiments, release regions for use in accordance with the present invention are in the form of a release layers, which cover all or a part of a medical device substrate. As used herein a "layer" of a given material is a region of that material whose thickness is small compared to both its length and width. As used herein a layer need not be planar or conformal (for example, taking on the contours of an underlying substrate). Layers can be discontinuous (*e.g.*, patterned). Terms such as "film," "layer" and "coating" may be used interchangeably herein.

[0040] As noted above, the release regions of the present invention comprise one or more polymers, typically at least 50 wt% polymers, at least 75 wt% polymers, at least 90 wt% polymers, at least 95 wt% polymers, or even more. The release regions may also contain therapeutic agents and further optional components, including but not limited to, radio-opacifying agents, colorants, and the like.

[0041] Numerous techniques are available for forming the polymeric release regions of the present invention. For example, where one or more polymers forming the release regions have thermoplastic characteristics, a variety of standard thermoplastic processing techniques can be used to form the release region, including compression molding, injection molding, blow molding, spinning, vacuum forming and calendaring, as well as extrusion into sheets, fibers, rods, tubes and other cross-sectional profiles of various lengths. In certain preferred embodiments, the device is formed using injection molding techniques. Although a wide array of polymers can be selected for making the devices of the present invention by processes such as injection molding, certain preferred polymers include EVA, polyurethanes, silicone and polyethylene.

[0042] Using these and other techniques, entire devices or portions thereof can be made. For example, an entire stent or uterine device can be extruded using the above techniques. As another example, a coating can be provided by extruding a coating layer onto a pre-existing stent or uterine device. As yet another example, a coating can be co-extruded along with an underlying stent body or uterine device body.

[0043] If the therapeutic agent is stable at processing temperatures, then it can be combined with the polymer(s) forming the release region prior to thermoplastic processing, producing a therapeutic-agent containing carrier region. If not, then a carrier

region can nonetheless be formed by subsequent introduction of therapeutic agent, for example, as discussed below. For example, therapeutic agents can be imbibed into an already formed polymer such as a polymer pigtail tip of a ureteral stent.

[0044] In some embodiments, processing may comprise dry blending, compounding or otherwise mixing one or more polymers, one or more therapeutic agents, and any further optional agents to form a relatively homogeneous mixture thereof and then shaping the homogenous mixture into a carrier region of a medical device. The mixing and shaping operations, as described more fully below, may be performed using any of the conventional devices known in the art for such purposes.

[0045] In the following description, the one or more therapeutic agents and further optional agents will, at times, be collectively referred to as "additives" or "agents."

[0046] Mixing or compounding polymer(s) with one or more of the therapeutic agents and further optional agents to form a relatively homogeneous mixture thereof may be performed with any device known in the art and conventionally used for mixing polymeric materials with additives. Where thermoplastic materials are employed, a polymer melt is formed by heating the various agents, which can then be mixed to form a more homogenous mixture. A common way of doing so is to apply mechanical shear to a mixture of the polymer and additives. Devices in which the polymer and additives may be mixed in this fashion include, but are not limited to, devices such as a single screw extruder, a twin screw extruder, a banbury mixer, a high-speed mixer, and a ross kettle.

[0047] Mixing may also be achieved by dissolving polymer(s) of interest with one or more of the therapeutic agents and further optional agents in a solvent system, as described below.

[0048] Any of the polymer(s) and/or additives may be precompounded or individually premixed to facilitate subsequent processing.

[0049] The mixture of polymer and additives can be shaped into at least a portion of a medical device in accordance with the present invention by means of any process conventionally used to shape polymeric materials such as thermoplastic and elastomeric materials. Among such shaping processes are included, but not limited to, extrusion including coextrusion, molding, calendaring, casting and coating.

[0050] Coextrusion is a shaping process that is useful wherein at least a portion of a

medical device in accordance with the present invention is a multilayer structure, for example, comprising one or more distinct carrier layers and one or more barrier layers at least partially covering a surface of a carrier layer. Multi-layer structures can also be formed by other processing and shaping techniques such as laminar injection molding (LIM) technology.

[0051] Alternatively, co-extrusion may comprise two polymer melts of different content, with or without additives, wherein, for example, the polymer melts are extruded according to a gradient such that the resultant medical device has sections with differing content. For example, melts producing polymeric regions of different durometer value may be extruded according to a gradient to form a device, such as a stent, with opposing end regions having respective polymer contents, and a transition region in between, which is a co-extrusion going from 100% of one polymer content at one end of the transition region to 100% of the other polymer content at the other end of the transition region. Other lengthwise co-extrusions are contemplated to form sections along the length of a medical device that have different polymer content, different therapeutic agents and/or different therapeutic agent concentrations.

[0052] Polymeric release regions can also be formed using solvent-based techniques in which one or more polymers are first dissolved or dispersed in a solvent and the resulting mixture is subsequently used to form a polymeric release region.

[0053] Where solvent-based techniques are used, the solvent system that is selected will contain one or more solvent species. The solvent system preferably is a good solvent for the polymer(s) within the release region and, where included, for the therapeutic agent and any supplemental additives. The particular solvent species that make up the solvent system may also be selected based on other characteristics including drying rate and surface tension.

[0054] Preferred solvent-based techniques include, but are not limited to, solvent casting techniques, spin coating techniques, web coating techniques, solvent spraying techniques, dipping techniques, techniques involving coating via mechanical suspension including air suspension, ink jet techniques, electrostatic techniques, and combinations of these processes.

[0055] In many embodiments, a mixture containing solvent, one or more polymers and

where included, therapeutic agent and any supplemental additive, is applied to a substrate to form a release region. For example, the substrate can be all or a portion of an implantable or insertable medical device, such as a stent or a uterine device, to which a release layer is applied. On the other hand, the substrate can also be, for example, a template such as a mold from which the release region is removed after solvent elimination. Such template-based techniques are particularly appropriate for forming objects such as sheets, tubes, cylinders and so forth, which can be easily removed from a template substrate.

[0056] In other techniques, for example, fiber forming techniques, the polymeric release region is formed without the aid of a substrate or template.

[0057] Where appropriate, techniques such as those listed above can be repeated or combined to build up a release region to a desired thickness. The thickness of the release region can be varied in other ways as well. For example, in one preferred process, solvent spraying, coating thickness can be increased by modification of coating process parameters, including increasing spray flow rate, slowing the movement between the substrate to be coated and the spray nozzle, providing repeated passes and so forth.

[0058] Where a carrier region is formed (as opposed to, for example, a barrier region), a therapeutic agent can be provided in a polymer solution or melt, and hence co-established with the carrier region. In other embodiments, on the other hand, the therapeutic agent can be dissolved or dispersed within a solvent, and the resulting solution contacted with a previously formed polymer region using, for example, one or more of the application techniques described above (e.g., dipping, spraying, etc.).

[0059] Barrier layers, on the other hand, may be formed over a therapeutic-agent-containing region, for example, using thermoplastic or solvent-based techniques such as those discussed above. The barrier layer serves, for example, as a boundary layer to retard diffusion of the therapeutic agent, for example, acting to prevent a burst phenomenon whereby much of the therapeutic agent is released immediately upon exposure of the device or a portion of the device to the implant or insertion site.

[0060] In some embodiments, the therapeutic-agent-containing region beneath the barrier region will comprise one or more polymers such as those described elsewhere herein. The polymeric composition of the barrier region may, or may not, be the same as the polymeric composition of the underlying therapeutic-agent-containing region. As such,

the therapeutic-agent-containing region can also be established using thermoplastic and solvent-based techniques such as those discussed above. In other embodiments, the therapeutic-agent-containing region beneath the barrier layer is established without an associated polymer. In this case, the therapeutic agent can simply be dissolved or dispersed in a solvent or liquid, and the resulting solution/dispersion can be contacted with a substrate again using, for instance, one or more of the above-described application techniques.

[0061] Where the release region is formed using a solvent-based technique, it is preferably dried after application to remove the solvents. The release region typically further conforms to any underlying surface during the drying process.

[0062] As indicated above, the polymers used in the urological and uterine devices of the present invention may be any biocompatible polymer suitable for use in implantable or insertable medical devices. The polymer may be substantially non-biodegradable or biodegradable.

[0063] Preferred substantially non-biodegradable biocompatible polymers include thermoplastic and elastomeric polymeric materials. Polymers for use in the devices of the present invention can be selected, for example, from polyolefins such as metallocene catalyzed polyethylenes, polypropylenes, and polybutylenes and copolymers thereof; vinyl aromatic polymers such as polystyrene; vinyl aromatic copolymers such as styrene-isobutylene copolymers and butadiene-styrene copolymers; ethylenic copolymers such as ethylene vinyl acetate (EVA), ethylene-methacrylic acid and ethylene-acrylic acid copolymers where some of the acid groups have been neutralized with either zinc or sodium ions (commonly known as ionomers); polyacetals; chloropolymers such as polyvinylchloride (PVC); fluoropolymers such as polytetrafluoroethylene (PTFE); polyesters such as polyethyleneterephthalate (PET); polyester-ethers; polyamides such as nylon 6 and nylon 6,6; polyamide ethers; polyethers; elastomers such as elastomeric polyurethanes and polyurethane copolymers; silicones; polycarbonates; and mixtures and block or random copolymers of any of the foregoing are non-limiting examples of non-biodegradable biocompatible polymers useful for manufacturing the medical devices of the present invention.

[0064] Among preferred non-biodegradable polymeric materials are polyolefins,

ethylenic copolymers including ethylene vinyl acetate copolymers (EVA) and copolymers of ethylene with acrylic acid or methacrylic acid; elastomeric polyurethanes and polyurethane copolymers; metallocene catalyzed polyethylene (mPE), mPE copolymers, ionomers, and mixtures and copolymers thereof; and vinyl aromatic polymers and copolymers. Among preferred vinyl aromatic copolymers are included copolymers of polyisobutylene with polystyrene or polymethylstyrene, even more preferably polystyrene-polyisobutylene-polystyrene triblock copolymers. These polymers are described, for example, in U.S. Patent No. 5,741,331, U.S. Patent No. 4,946,899 and U.S. Patent No. 6,545,097, each of which is hereby incorporated by reference in its entirety. Ethylene vinyl acetate (EVA) having a vinyl acetate content of from about 19% to about 28% is an especially preferred non-biodegradable material. EVA copolymers having a lower vinyl acetate content of from about 3% to about 15% are also useful in particular embodiments of the present invention as are EVA copolymers having a vinyl acetate content as high as about 40%. These relatively higher vinyl acetate content copolymers may be beneficial in offsetting stiffness from coextruded barrier layers. Among preferred elastomeric polyurethanes are block and random copolymers that are polyether based, polyester based, polycarbonate based, aliphatic based, aromatic based and mixtures thereof. Commercially available polyurethane copolymers include, but are not limited to, Carbothane®, Tecoflex®, Tecothane®, Tecophilic®, Tecoplast®, Pellethane®, Chronothane® and Chronoflex®. Other preferred elastomers include polyester-ethers, polyamide-ethers and silicone.

[0065] Preferred biodegradable polymers can be selected, for example, from polylactic acid, polyglycolic acid and copolymers and mixtures thereof such as poly(L-lactide) (PLLA), poly(D,L-lactide) (PLA); polyglycolic acid [polyglycolide (PGA)], poly(L-lactide-co-D,L-lactide) (PLLA/PLA), poly(L-lactide-co-glycolide) (PLLA/PGA), poly(D,L-lactide-co-glycolide) (PLA/PGA), poly(glycolide-co-trimethylene carbonate) (PGA/PTMC), poly(D,L-lactide-co-caprolactone) (PLA/PCL), poly(glycolide-co-caprolactone) (PGA/PCL); polyethylene oxide (PEO), polydioxanone (PDS), polypropylene fumarate, poly(ethyl glutamate-co-glutamic acid), poly(tert-butyloxy-carbonylmethyl glutamate), polycaprolactone (PCL), polycaprolactone co-butylacrylate, polyhydroxybutyrate (PHBT) and copolymers of polyhydroxybutyrate, poly(phosphazene), poly(phosphate ester), poly(amino acid) and poly(hydroxy butyrate),

polydepsipeptides, maleic anhydride copolymers, polyphosphazenes, polyiminocarbonates, poly[(97.5% dimethyl-trimethylene carbonate)-co-(2.5% trimethylene carbonate)], cyanoacrylate, polyethylene oxide, polyvinyl alcohol (PVA), polyvinylpyrrolidone (PVP), chemically modified celluloses such as hydroxypropylmethylcellulose and regenerate cellulose, polysaccharides such as hyaluronic acid, chitosan, alginates and modified starch such as pentastarch and hydroxyethyl starch, proteins such as gelatin and collagen, and mixtures and copolymers thereof, among others.

[0066] The medical devices of the present invention, for example, the urological devices, may also contain a radio-opacifying agent within its structure. For example, the radio-opacifying agent may be present in or on any of the carrier or barrier regions found in the devices. The radio-opacifying agent facilitates viewing of the medical device during insertion of the device and at any point while the device is implanted. A radio-opacifying agent typically functions by scattering x-rays. The areas of the medical device that scatter the x-rays are detectable on a radiograph. Among radio-opacifying agents useful in the medical device of the present invention are included, but not limited to, bismuth subcarbonate, bismuth oxychloride, bismuth trioxide, barium sulfate, tungsten and mixtures thereof. Where present, the radio-opacifying agent is preferably present in an amount of from about 0.5% to about 90%, more preferably from about 10% to about 90% by weight, of the polymer. A particularly preferred amount of radio-opacifying agent is from about 10 to about 40% by weight of the polymer.

[0067] Other optional agents may include, for example, antimicrobial agents that have been added in an amount effective to inhibit the growth of microbes on or around the device as well as any antimicrobial agents added for therapeutic purposes. Antimicrobial agents include, for example, triclosan, chlorhexidine and combinations thereof. In some embodiments, a lubricious hydrophilic coating may be applied to the surface of the urological devices and uterine devices of the present invention.

A. Urological Devices

[0068] As used herein, the term "urological devices" include medical devices that are adapted for placement in any part of the human urinary tract, including ureteral and urethral stents, urinary catheters such as Foley catheters, and the like.

[0069] As discussed above, in one aspect of the invention, a urological medical device is provided comprising a first therapeutic agent for treating a urological condition, wherein the medical device is adapted, upon implantation or insertion into a patient, to release all or a majority of the first therapeutic agent from a portion of the medical device that occupies the urinary bladder.

[0070] Ureteral stents, for example, are typically used to facilitate urinary drainage from the kidney to the bladder in patients having a ureteral obstruction or injury, or to protect the integrity of the ureter in a variety of surgical manipulations. They are used, for example, in post endo-urological procedures to act as a scaffold in the event of ureteral obstruction secondary to the procedure. Stents are also used as palliative devices to provide patency in the presence of congenital defects, strictures or malignancies that cause a ureter obstruction.

[0071] Any of a number of ureteral stent designs may be employed for the present invention. For example, the urological device of the present invention may comprise a tubular member, a renal retention structure on the distal end of the tubular member and a bladder retention structure on the proximal end of the tubular member.

[0072] In some preferred embodiments, the ureteral stents of the present invention are formed based on the design of the Percuflex® Ureteral Stent, which is commercially available from Boston Scientific, Natick, MA, USA. As would be appreciated by one of ordinary skill in the art, other ureteral stent designs may be employed such as that of the Contour™ Stent, also commercially available from Boston Scientific, and those disclosed in U.S. Patent Nos. 6,656,146, 6,719,804, 6,685,744, and 6,648,863, all of which are commonly assigned to SciMed Life Systems, Inc., and the contents of which are incorporated by reference in their entirety.

[0073] A schematic diagram of one exemplary stent 10 is illustrated in Fig. 1. Conventional retention structures typically include spirals, pigtails, coils, corkscrews, mallincotts, barbs, mushrooms or hook ends designed to retain the stent within the ureter and all are within the scope of the present invention. In some embodiments, the stent 10 is a tubular polymer extrusion containing a tubular member (e.g., shaft 12), a distal renal retention structure (e.g., renal pigtail 14), and a proximal retention structure (e.g., bladder pigtail 16). These retention structures prevent upward migration of the stent toward the kidney or downward migration of the stent into the ureter. In other embodiments, the

proximal retention structure comprises a mallincott instead of a bladder pigtail. The tubular member may comprise a melt-extruded polymeric tubular shaft as well as those produced according to any number of other processing methods as detailed above.

[0074] The stent 10 having two pigtails 14, 16, is inserted into the ureter to provide ureteral rigidity and to allow the passage of urine. The pigtails 14, 16 serve to keep the stent 10 in place once positioned by the physician. The stent 10, as exemplified by Fig. 1, may further be provided with any one or more of the following: (a) a tapered tip 11 (not shown), to aid insertion, (b) multiple side ports 18 (one numbered), which are typically arranged in a spiral pattern down the length of the body to promote drainage, (c) graduation marks 20 (one illustrated), which are normally used for visualization by the physician to know when the appropriate length of stent has been inserted into the ureter, and (d) a Nylon suture 22, which aids in positioning and withdrawal of the stent, as is known in that art. During placement, such ureteral stents 10 are typically placed over a urology guide wire, through a cystoscope and advanced into position with a positioner. Once the proximal end of the stent is advanced into the kidney/renal calyx, the guide wire is removed, allowing the pigtails 14, 16 to form in the kidney 19 and bladder 20, as shown in Fig. 2. The renal pigtail 14 of the stent may be closed or tapered, depending on the method of insertion (e.g., the use of a guide wire). As shown in Fig. 2, the stent extends through the ureteral orifice 21a and into the bladder. For clarity, the ureter entering bladder 20 through orifice 21b is not shown.

[0075] The bladder retention structure comprises a first release region that comprises a biocompatible polymer and the first therapeutic agent is disposed beneath or within the release region. The device may further comprise at least one other release region, contained in the tubular member or renal retention structure or both, which comprises a biocompatible polymer and beneath or within which a second therapeutic agent is disposed, which may be the same as or different from the first therapeutic agent.

[0076] As would be appreciated by one of ordinary skill in the art, the first release region and other release regions may contain the same therapeutic agent in different concentrations such that a concentration gradient exists in the device. The first release region may contain a higher concentration of the therapeutic agent than other release regions. Alternatively, the first and second therapeutic agents are different. For example, the bladder pigtail 16 alone can contain a therapeutic agent for treating interstitial cystitis

such as pentosan polysulfate, heparin, amitripyline, imipramine, hydroxyzine, dihydrochloride, hydroxyzine hydrochloride, hyoscyamine sulfate, hyosyamine, oxybutynin chloride, flavoxate, urised, phenazopyridine hydrochloride, DMSO, sodium oxychlorosene, lidocaine, hydrocortisone sodium succinate, sodium bicarbonate, capsaicin, hyaluronic acid silver nitrate or bacillus of Calmette and Guerin (BCG), or a combination of one or more of these agents.

[0077] Also, the bladder pigtail 16 may comprise a higher concentration of these or other therapeutic agents than concentrations in the renal pigtail 14 or the shaft 12.

[0078] The urological device may also reside completely in the urinary bladder, and take any of a number of forms, including a hollow three dimensional structure comprising a balloon, an annular ring, a disk, or a shaft, or other structure adapted for residence entirely within the bladder. To facilitate removal of the structure from the body, the device may further comprise a retraction means for removing the device from the bladder and out of the body. Typically, the retraction means is attached to a proximal portion of the structure and can comprise, for example, a suture or thread.

[0079] In other embodiments, the urological device comprises a urinary catheter such as a Foley catheter having a balloon structure and a catheter tip wherein the polymer release region containing the therapeutic agent is disposed over all or a portion of the medical device substrate. For example, the polymer used to create the Foley catheter tip or balloon is mixed or compounded with a therapeutic agent such as heparin as described in the processing details above.

[0080] In yet other embodiments, the urological device of the present invention comprises a urethral stent wherein the carrier region containing the therapeutic agent is disposed at least over a portion of the stent that will be placed in or near the bladder.

[0081] Techniques for forming urinary stents, including urethral and ureteral stents, are described in detail in U.S. Patent Application Publication No. 2003/0153983 to Kathleen M. Miller et al., the disclosure of which is hereby incorporated by reference. In brief, methods are described for forming stents which contain (a) a therapeutic agent (b) a radio-opacifying agent, (c) a colorant and (d) the balance ethylene vinyl acetate (EVA) copolymer (e.g., Elvax 460, from DuPont). First, the therapeutic agent, radio-opacifying agent and colorant are pre-blended to produce a consistent, homogenous powder blend. The pre-blended mixture is then compounded with the EVA copolymer and extruded into

pellets, which are then extruded into tubes of an appropriate diameter. For the stent devices, the extruded material is then cut, provided with a tapered tip, annealed, marked with ink and coated with a lubricious hydrophilic coating (Hydroplus™ (Union Carbide, Dow Chemical)), followed by side port formation, pigtail formation by hot air treatment, and the addition of the suture, as is known in the art.

[0082] In some other embodiments, only the pigtail portion of the device comprises a polymer release region containing or disposed over the therapeutic agents. Fabricated, for example, according to one of the processing techniques discussed above, in some embodiments, a preformed pigtail (e.g., a bladder pigtail containing a desired therapeutic agent) may be attached (e.g., thermally) to a stent main body to form a finished device. The stent main body itself may be comprised of any number of standard stent materials known in the art including polymeric or metallic materials.

[0083] "Therapeutic agents", "pharmaceutically active agents", "pharmaceutically active materials", "drugs" and other related terms may be used interchangeably herein and include genetic therapeutic agents, non-genetic therapeutic agents and cells. Therapeutic agents may be used singly or in combination. Therapeutic agents may be, for example, nonionic or they may be anionic and/or cationic in nature.

[0084] Exemplary therapeutic agents for use in connection with the urological devices of the present invention include: (a) non-steroidal anti-inflammatory agents (NSAIDS) (e.g., ibuprofen and naproxen); (b) steroidal anti-inflammatory agents (e.g., prednisolone and dexamethasone); (c) antihistamines (e.g., hydroxyzine); (d) antidepressants such as tricyclic antidepressants (e.g., amitriptyline or imipramine) or a selective serotonin reuptake inhibitor (SSRI) such as fluoxetine, paroxetine or sertraline; (e) calcium channel blockers (e.g., nifedipine); (f) dimethyl sulfoxide (DMSO); (g) pentosan polysulfate sodium (PPS, Elmiron®); (h) anesthetic agents such as lidocaine, bupivacaine and ropivacaine; (i) heparinoid therapy including heparin; (j) heparin-binding epidermal growth factor-like growth factor (HB-EGF); (k) glycosaminoglycans (e.g., hyaluronic acid); (l) antibiotics such as Macrochantin® and Augmentin®; (m) analgesics such as salicylic acid; (n) antimicrobial agents such as triclosan, cephalosporins, aminoglycosides and nitrofurantoin; and (o) potassium chelating agents such as potassium citrate. Other therapeutic agents include sodium succinate, sodium bicarbonate, capsaicin,

silver nitrate, or bacillus of Calmette and Guerin (BCG). Combinations of any of the foregoing are also used.

[0085] In preferred embodiments, the therapeutic agent comprises a combination of pentosan polysulfate and heparin.

[0086] Examples of non-steroidal anti-inflammatory drugs for use as therapeutic agents include: aminoarylcarboxylic acid derivatives such as enfenamic acid, etofenamate, flufenamic acid, isonixin, meclofenamic acid, mefenamic acid, niflumic acid, talniflumate, terofenamate and tolfenamic acid; arylacetic acid derivatives such as acetaminacin, alclofenac, amfenac, bufexamac, cinmetacin, clopirac, diclofenac sodium, etodolac, felbinac, fenclofenac, fenclorac, fenclozic acid, fentiazac, glucametacin, ibufenac, indomethacin, isofezolac, isoxepac, lonazolac, metiazinic acid, oxametacine, proglumetacin, sulindac, tiaramide, tolmetin and zomepirac; arylbutyric acid derivatives such as bumadizon, butibufen, fenbufen and xenbucin; arylcarboxylic acids such as clidanac, ketorolac and tinoridine; arylpropionic acid derivatives such as alminoprofen, benoxaprofen, bucloxic acid, carprofen, fenoprofen, flunoxaprofen, flurbiprofen, ibuprofen, ibuproxam, indoprofen, ketoprofen, loxoprofen, miroprofen, naproxen, oxaprozin, piketoprofen, pirprofen, pranoprofen, protizinic acid, suprofen and tiaprofenic acid; pyrazoles such as difenamizole and epirizole; pyrazolones such as apazone, benzpiperylon, feprazone, mofebutazone, morazone, oxyphenbutazone, phenybutazone, pipebuzone, propyphenazone, ramifenazone, suxibuzone and thiazolinobutazone; salicylic acid and its derivatives such as acetaminosalol, aspirin, benorylate, bromosaligenin, calcium acetylsalicylate, diflunisal, etersalate, fendosal, gentisic acid, glycol salicylate, imidazole salicylate, lysine acetylsalicylate, mesalamine, morpholine salicylate, 1-naphthyl salicylate, olsalazine, parsalimide, phenyl acetylsalicylate, phenyl salicylate, salacetamide, salicylamine o-acetic acid, salicylsulfuric acid, salsalate and sulfasalazine; thiazinecarboxamides such as droxicam, isoxicam, piroxicam and tenoxicam; others such as ϵ -acetamidocaproic acid, s-adenosylmethionine, 3-amino-4-hydroxybutyric acid, amixetrine, bendazac, benzydamine, bucolome, difenpiramide, ditazol, emorfazone, guaiazulene, nabumetone, nimesulide, orgotein, oxaceprol, paranyline, perisoxal, pifoxime, proquazone, proxazole and tenidap; and pharmaceutically acceptable salts and esters thereof; as well as combinations thereof.

[0087] Examples of steroidal anti-inflammatory agents include prednisolone,

methylprednisolone, hydrocortisone, flumethasone pivalate, triamcinolone, dexamethasone, betamethasone, amcinonide, and difluprednate.

B. Uterine Devices

[0085] The present invention is also directed to uterine devices for the treatment of uterine conditions which is adapted to conform to the general contours of an interior cavity of a human female uterus. The devices comprise at least one release region that controls the release of at least one therapeutic agent (which is disposed beneath or within the release region) for treating a uterine condition.

[0086] For example, in some embodiments, the uterine device comprises a contoured structure made of a flexible material having the general contours of an interior cavity of a mammalian (e.g., human) female uterus.

[0087] Referring to Fig. 3A, the present invention provides, in one embodiment, a uterine device 100 for the treatment of a uterine condition such as uterine fibroids. For instance, the device may comprise a contoured structure 110 made of a flexible material wherein an outer surface of the contoured structure 110 has the general contours of an interior cavity of a human female uterus. Thus, the contoured structure 110, may comprise a collapsible or inflatable three dimensional structure such as, for example, hollow three-dimensional structures like an inflatable "balloon," an irregular cone, irregular spheres, and the like. In addition to hollow three-dimensional structures, the contoured structure 110 may also comprise a continuous hoop of flexible material, e.g., irregular ring, and other predominantly two-dimensional structures whose length and width are appreciably greater than the thickness of the hoop. The contoured hoop, for example, may be made of a continuous length of a flexible material, e.g., a long cylinder, ribbon or tape of a soft polyurethane or other flexible polymeric material having a cross-sectional area that is circular, elliptical, rectangular, square, or the like. Both the hollow three-dimensional structures and the predominantly two-dimensional "hoops" are contoured such that when placed within the uterus, surface to surface contact between the outer surface of the device and the uterine wall is achieved. One or more therapeutic agents 112 are dispersed, dissolved or otherwise incorporated within a release region of the flexible material.

[0088] To facilitate ease of insertion of the uterine device, the device may be compressed

and withdrawn into a delivery sheath 130 as shown in Fig. 3B. Once the delivery sheath 130 has been placed through the cervix and into the uterine cavity, the sheath is retracted from the body. Due to the nature of the material forming the device, upon emerging from the sheath, the device self expands in the uterus to contact the walls of the uterus, described above, or is pushed into contact with the walls of the uterus, such as, for example, where the device is an inflatable balloon in the shape of the uterine cavity. Threads 120 or other means for removing the device from the body allow for easy extraction of the device upon completion of the treatment or replacement with a new uterine device 100 having other therapeutic agents 112 or the same therapeutic agent(s) at differing concentrations, for example, by pulling the device 100 into the sheath 130 to form a compressed configuration and then pulling the delivery sheath through the cervical opening and out of the body.

[0089] Referring to Fig. 4, a uterine device of the present invention as positioned within the uterus is shown. The size of the uterine device may be readily adapted to suit the size requirements of the individual patient. Generally, however, it is preferable that the general size of the device 100 be about the same or larger than that of the uterine cavity, such that upon deployment within the uterus, the device 100 exerts a positive tension in opposition to the uterine wall such that surface to surface contact between the device and the uterine wall is achieved. This facilitates direct contact and absorption of the therapeutic agents released by the device into the uterine lining where many conditions such as fibroids or endometriosis exist.

[0090] In alternative embodiments, the general shape of the uterine device may be that of typical intrauterine devices currently available as contraceptives (e.g., Mirena®, a T-shaped levonorgestrel-releasing intrauterine system sold by Berlex Laboratories) and other T-shaped intrauterine devices described, for example, in U.S. Patent Nos. 3,993,057 and 4,578,076. In yet other embodiments, the device may be in the form of a concave disk that covers the cervix, similar in structure to diaphragms used for contraceptive purposes by women.

[0091] Exemplary therapeutic agents for use in connection with the uterine devices of the present invention include: (a) steroidal and non-steroidal anti-inflammatory agents (NSAIDs) such as dexamethasone, prednisolone, corticosterone, budesonide, estrogen, sulfasalazine and mesalamine; (b) contraceptives, (c) hormonal replacement therapy

agents, and (d) GnRH agonists. Other therapeutic agents for the treatment of uterine conditions, in addition to the NSAIDs, contraceptives, and GnRH agonists discussed above include synthetic androgens, such as danazol (e.g., DANOCRINE®), antiprogestins, such as gestrinone and mifepristone (e.g., MIFEPREX®), selective progesterone receptor modulators (SPRMs), such as asoprisnil, selective estrogen receptor modulators (SERMs), and aromatase inhibitors, such as anastrozole (e.g., ARIMIDEX®), letrozole (e.g., FEMARA®) and exemestane (e.g., AROMASIN®), antiestrogens (e.g., tamoxifen and fulvestrant), among other agents.

[0092] Examples of non-steroidal and steroidal anti-inflammatory drugs for use as uterine treatment agents can be selected from those described above.

[0093] Examples of contraceptives for use as uterine fibroid treatment agents include: desogestrel, ethinyl estradiol, ethynodiol, ethynodiol diacetate, gestodene, lynestrenol, levonorgestrel, mestranol, medroxyprogesterone, norethindrone, norethynodrel, norgestimate, norgestrel, pharmaceutically acceptable salts and esters thereof, and combinations thereof. Specific examples include: norethynodrel/mestranol (e.g., ENOVID™), ethinyl estradiol/norethindrone (e.g., LOESTRIN™, BREVICON™, MODICON™, GENORA™, NELONA™, NORINYL™, OVACON-35™ and OVACON-50™), ethinyl estradiol/levonorgestrel (e.g., LEVLEN™, NORDETTE™, TRI-LEVLEN™ and TRIPHASIL-21™), ethinyl estradiol/norgestrel (e.g., LO/OVRAL™ and OVRAL™), ethinyl estradiol/ethynodiol diacetate (DEMULEN™), norethindrone/mestranol (e.g., NORINYL™, ORTHO-NOVUMO, NORETHIN™, GENORA™, and NELOVA™), ethinyl estradiol/desogestrel (e.g., DESOGEN™ and ORTHO-CEPT™), ethinyl estradiol/norgestimate (e.g., ORTHO-CYCLEN™ and ORTHO-TRICYCLEN™), norethindrone (e.g., MICRONOR™ and NOR-QD™), and norgestrel (e.g., OVRETTE™).

[0094] Examples of GnRH agonists for use as uterine fibroid treatment agents include: buserelin, cetorelix, decapeptyl, deslorelin, dioxalan derivatives, eulexin, ganirelix, gonadorelin hydrochloride, goserelin (ZOLADEX®), goserelin acetate, histrelin, histrelin acetate, leuprolide (e.g., LUPRON®), leuprolide acetate, leuprorelin, lutrelin, nafarelin (e.g., SYNAREL®) meterelin, triptorelin, further pharmaceutically acceptable salts and esters thereof, and combinations thereof.

[0095] Preferred therapeutic agents for the treatment of uterine conditions such as

fibroids and endometriosis comprise, for example, LUPRON®, progestins, PANAZOL® and oral contraceptives.

[0096] Although various embodiments are specifically illustrated and described herein, it will be appreciated that modifications and variations of the present invention are covered by the above teachings and are within the purview of the appended claims without departing from the spirit and intended scope of the invention.

What is claimed is:

1. A urological medical device comprising a first therapeutic agent for treating a urological condition, wherein said medical device is adapted, upon implantation or insertion into a patient, to release all or a majority of said first therapeutic agent from a portion of said medical device that occupies the urinary bladder.
2. The device of claim 1, wherein the urological condition comprises interstitial cystitis.
3. The device of claim 1, wherein said device further comprises a second therapeutic agent.
4. The device of claim 1, wherein said therapeutic agent is disposed beneath or within at least one release region that comprises a biocompatible polymer.
5. The device of claim 4, wherein said release region comprises a plurality of biocompatible polymers.
6. The device of claim 1, wherein said therapeutic agent is released only from said portion of said medical device that occupies the urinary bladder.
7. The device of claim 1, wherein said device resides completely in the urinary bladder.
8. The device of claim 7, wherein said device comprises a hollow three dimensional structure comprising a balloon, an annular ring, a disk, or a shaft.
9. The device of claim 7, wherein the device further comprises a retraction means for removing the device from the bladder and out of the body, wherein the retraction means is attached to a proximal portion of the structure.

10. The device of claim 9, wherein the retraction means comprises a suture or thread.
11. The device of claim 1, wherein said device comprises a tubular member, a renal retention structure on the distal end of the tubular member and a bladder retention structure on the proximal end of the tubular member.
12. The device of claim 11, wherein the bladder retention structure comprises a first release region that comprises a biocompatible polymer and wherein said first therapeutic agent is disposed beneath or within said release region.
13. The device of claim 12, wherein the device further comprises at least one other release region, contained in the tubular member or renal retention structure or both, which comprises a biocompatible polymer and beneath or within which a second therapeutic agent is disposed, which may be the same as or different from said first therapeutic agent.
14. The device of claim 13, wherein the first release region and other release regions contain the same therapeutic agent in different concentrations such that a concentration gradient exists in the device.
15. The device of claim 14, wherein the first release region contains a higher concentration of the therapeutic agent than other release regions.
16. The device of claim 13, wherein the first and second therapeutic agents are different.
17. The device of claim 1, wherein the first therapeutic agent comprises pentosan polysulfate or heparin, amitriptyline, imipramine, hydroxyzine, dihydrochloride, hydroxyzine hydrochloride, hyoscyamine sulfate, hyosyamine, oxybutynin chloride, flavoxate, urised, phenazopyridine hydrochloride, DMSO, sodium oxychlorosene, lidocaine, hydrocortisone sodium succinate, sodium bicarbonate, capsaicin, hyaluronic acid silver nitrate or bacillus of Calmette and Guerin (BCG).

18. The device of claim 14, wherein the first release region and other release regions contain the same therapeutic agent and wherein the release regions are adapted such that the therapeutic agent is released at higher concentrations in the bladder retention structure.
19. The device of claim 11, wherein the urological condition comprises interstitial cystitis.
20. The device of claim 4, wherein said release region(s) comprises a biocompatible biodegradable polymer.
21. The device of claim 4, wherein said release region(s) comprise a biocompatible non-biodegradable polymer.
22. The device of claim 21, wherein said non-biodegradable polymer is selected from the group consisting of ethylene vinyl acetate copolymers, copolymers of ethylene with acrylic acid or methacrylic acid, elastomeric polyurethanes and polyurethane copolymers, metallocene catalyzed polyethylene, ionomers and vinyl aromatic copolymers.
23. The device of claim 20, wherein said biodegradable polymer is selected from the group consisting of polylactic acid, polyglycolic acid, polycaprolactone, and copolymers and mixtures thereof.
24. The device of claim 21, wherein said non-biodegradable polymer is an ethylene vinyl acetate copolymer.
25. The device of claim 1, wherein the therapeutic agent is selected from the group consisting of non-steroidal anti-inflammatory agents, steroidal anti-inflammatory agents, antihistamines, tricyclic antidepressants, selective serotonin reuptake inhibitors, calcium channel blockers, dimethyl sulfoxide, pentosan polysulfate sodium, anesthetic agents comprising lidocaine, bupivacaine and ropivacaine, heparinoids comprising heparin, heparin-binding epidermal growth factor-like growth factor, glycosaminoglycans

comprising hyaluronic acid, antibiotics, analgesics comprising salicylic acid, antimicrobial agents comprising triclosan, cephalosporins, aminoglycosides or nitrofurantoin, potassium chelating agents comprising potassium citrate, sodium succinate, sodium bicarbonate, capsaicin, silver nitrate, and bacillus of Calmette and Guerin, or combinations thereof.

26. The device of claim 1, wherein the therapeutic agent is selected from the group consisting of pentosan polysulfate sodium and heparin, or combinations thereof.
27. The device of claim 1, wherein said polymer further comprises a radio-opacifying agent.
28. The device of claim 4, wherein said release region is a barrier layer at least partially covering a source of therapeutic agent.
29. The device of claim 1, further comprising an antimicrobial agent present in an amount effective to inhibit the growth of microbes on and around the device.
30. The device of claim 4, wherein the antimicrobial agent is selected from the group consisting of triclosan, chlorhexidine and combinations thereof.
31. The device of claim 1, further comprising a lubricious hydrophilic coating on a surface of said device.
32. The device of claim 11, wherein said device comprises a melt-extruded polymeric tubular shaft.
33. The device of claim 11, wherein the device comprises a ureteral stent, a urethral stent or a urinary catheter.
34. A uterine device for the treatment of a uterine condition comprising a contoured structure of a flexible material having the general contours of an interior cavity of a

human female uterus wherein the device comprises a therapeutic agent for treating a uterine condition.

35. The device of claim 34, wherein said device further comprises a second therapeutic agent.

36. The device of claim 34, wherein said device comprises a release region that comprises a biocompatible polymer and wherein the therapeutic agent is disposed beneath or within the release region.

37. The device of claim 36, wherein said release region comprises a plurality of biocompatible polymers.

38. The device of claim 36, wherein said device comprises a plurality of said release regions.

39. The device of claim 36, wherein said release region comprises a biocompatible biodegradable polymer.

40. The device of claim 36, wherein said release region comprises a biocompatible non-biodegradable polymer.

41. The device of claim 40, wherein said non-biodegradable polymer is selected from the group consisting of ethylene vinyl acetate copolymers, copolymers of ethylene with acrylic acid or methacrylic acid, elastomeric polyurethanes and polyurethane copolymers, metallocene catalyzed polyethylene, ionomers, silicone, and vinyl aromatic copolymers.

42. The device of claim 39, wherein said biodegradable polymer is selected from the group consisting of polylactic acid, polyglycolic acid, polycaprolactone, and copolymers and mixtures thereof.

43. The device of claim 40, wherein said non-biodegradable polymer is an ethylene vinyl acetate copolymer.
44. The device of claim 34, wherein the therapeutic agent is selected from the group consisting of non-steroidal anti-inflammatory agents, steroidal anti-inflammatory agents, contraceptives, hormonal replacement therapy agents, LUPRON®, PANAZOL®, GnRH agonists, danazol, antiprogestins comprising gestrinone and mifepristone, selective progesterone receptor modulators comprising asoprisnil, selective estrogen receptor modulators, aromatase inhibitors comprising anastrozole, letrozole and exemestane, and antiestrogens comprising tamoxifen and fulvestrant and combinations thereof.
45. The device of claim 34, wherein the therapeutic agent is selected from the group consisting of contraceptives and GnRH agonists, or combinations thereof.
46. The device of claim 36, wherein the release region comprises a biocompatible non-biodegradable polymer comprising therapeutic agent is selected from the group consisting of Ethylene Vinyl Acetate (EVA) and the therapeutic agent is selected from the group consisting of GnRH agonists, LUPRON®, progestins and oral contraceptives.
47. The device of claim 36, wherein said release region is a barrier layer at least partially covering a source of therapeutic agent.
48. The device of claim 34, further comprising an antimicrobial agent present in an amount effective to inhibit the growth of microbes on and around the device.
49. The device of claim 48, wherein the antimicrobial agent is selected from the group consisting of triclosan, chlorhexidine and combinations thereof.
50. The device of claim 34, further comprising a lubricious hydrophilic coating on a surface of said device.
51. The device of claim 34, wherein said device is produced by injection molding.

52. The device of claim 34, wherein the uterine condition comprises uterine fibroids or endometriosis.
53. The device of claim 34, wherein the contoured structure comprises a hollow three-dimensional shape selected from a balloon, an irregular cone, an irregular sphere.
54. The device of claim 34, wherein the contoured structure comprises a continuous hoop comprising an irregular ring.

1/4

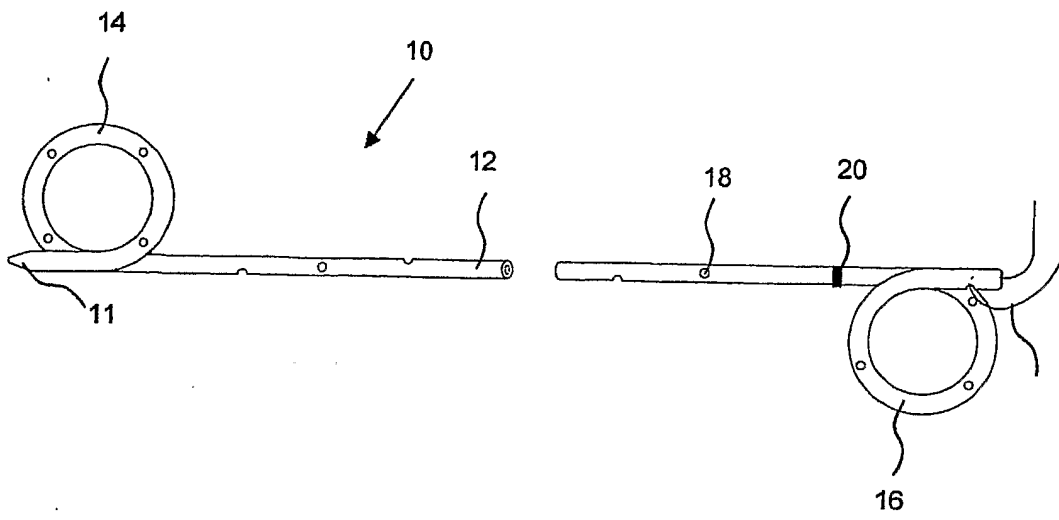

FIG 1

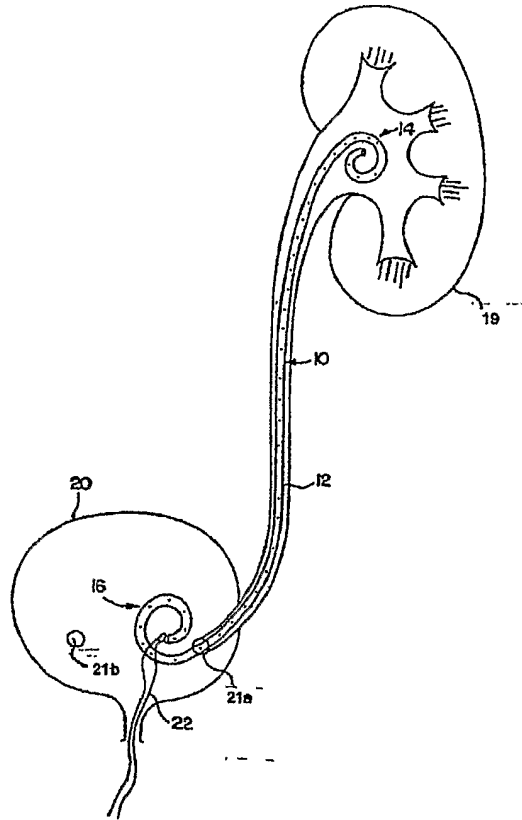

FIG 2

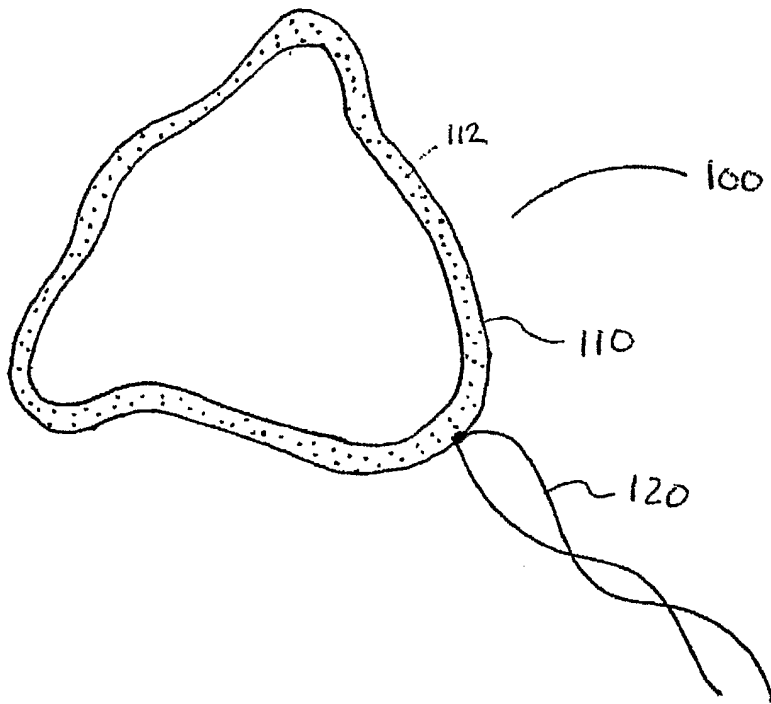

FIG 3A

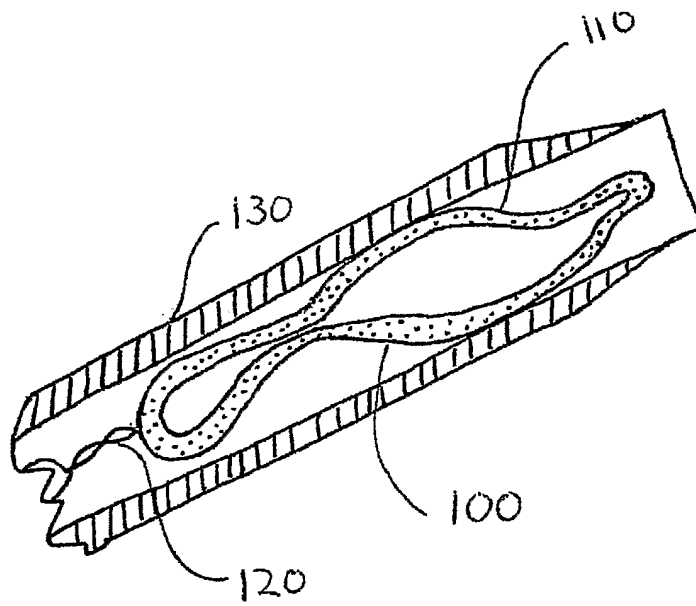

FIG 3B

4/4

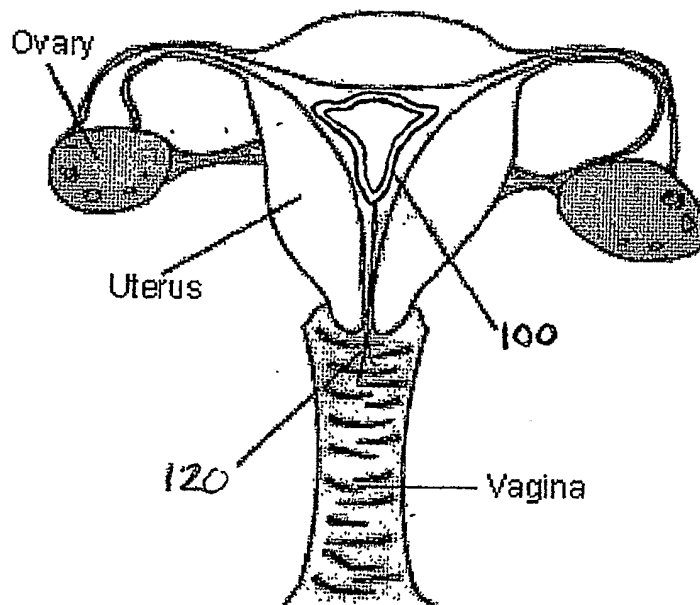

FIG 4

INTERNATIONAL SEARCH REPORT

International application No
PCT/US2006/017618

A. CLASSIFICATION OF SUBJECT MATTER
 INV. A61M31/00 A61M25/00 A61F6/14 A61L29/00

According to International Patent Classification (IPC) or to both national classification and IPC

B. FIELDS SEARCHED
 Minimum documentation searched (classification system followed by classification symbols)
 A61M A61F A61L A61K

Documentation searched other than minimum documentation to the extent that such documents are included in the fields searched

Electronic data base consulted during the international search (name of data base and, where practical, search terms used)
 EPO-Internal, WPI Data

C. DOCUMENTS CONSIDERED TO BE RELEVANT

Category*	Citation of document, with indication, where appropriate, of the relevant passages	Relevant to claim No.
X	WO 2004/010975 A (SCIMED LIFE SYSTEMS INC) 5 February 2004 (2004-02-05)	1,3,4, 6-8, 11-18, 20-22, 24,25, 31-33
Y	paragraph [0020] - paragraph [0060]; figures 1-7	5,19,23, 26-30
A		34-36, 38-41, 43,44, 47,51
	----- -/--	

Further documents are listed in the continuation of Box C. See patent family annex.

* Special categories of cited documents :

"A" document defining the general state of the art which is not considered to be of particular relevance	"T" later document published after the international filing date or priority date and not in conflict with the application but cited to understand the principle or theory underlying the invention
"E" earlier document but published on or after the international filing date	"X" document of particular relevance; the claimed invention cannot be considered novel or cannot be considered to involve an inventive step when the document is taken alone
"L" document which may throw doubts on priority claim(s) or which is cited to establish the publication date of another citation or other special reason (as specified)	"Y" document of particular relevance; the claimed invention cannot be considered to involve an inventive step when the document is combined with one or more other such documents, such combination being obvious to a person skilled in the art.
"O" document referring to an oral disclosure, use, exhibition or other means	"&" document member of the same patent family
"P" document published prior to the international filing date but later than the priority date claimed	

Date of the actual completion of the international search 14 September 2006	Date of mailing of the international search report 25/09/2006
--	--

Name and mailing address of the ISA/ European Patent Office, P.B. 5818 Patentlaan 2 NL - 2280 HV Rijswijk Tel. (+31-70) 340-2040, Tx. 31 651 epo nl, Fax: (+31-70) 340-3016	Authorized officer Jameson, Patricia
---	---

INTERNATIONAL SEARCH REPORT

International application No

PCT/US2006/017618

C(Continuation). DOCUMENTS CONSIDERED TO BE RELEVANT

Category*	Citation of document, with indication, where appropriate, of the relevant passages	Relevant to claim No.
X	WO 00/64513 A (SITUS CORPORATION) 2 November 2000 (2000-11-02)	1-3, 6-10,17, 25,26,31
Y	page 2, line 17 - page 3, line 19 page 12, line 12 - page 14, line 7; figures 6-8 page 19, line 6 - page 21, line 35	19
X	US 6 293 923 B1 (YACHIA DANIEL ET AL) 25 September 2001 (2001-09-25) column 2, line 64 - column 3, line 15 column 5, line 41 - column 6, line 19; figures 1-6 column 6, line 57 - column 7, line 15; figure 11	1-3,6-9, 29
X	EP 0 372 137 A (FERRING, B.V) 13 June 1990 (1990-06-13) column 3, line 46 - column 5, line 49; figures 1-8	1,4,6-8, 21
X	US 2002/161352 A1 (LIN CHEN HAI ET AL) 31 October 2002 (2002-10-31)	34,36, 40,41, 44,45, 47,51, 52,54 35,37, 42,48-50
Y	paragraph [0001] - paragraph [0049]; figures 1-2c	
X	US 3 993 057 A (RAMWELL ET AL) 23 November 1976 (1976-11-23) cited in the application column 3, line 59 - column 6, line 6; figures 1-7 column 11, line 35 - column 16, line 44	34-39, 44,45, 53,54
X	GB 1 414 812 A (ALZA CORPORATION) 19 November 1975 (1975-11-19)	34,36, 40,44, 45,47, 53,54
A	page 2, line 104 - page 4, line 45 page 6, line 54 - page 7, line 7; figures 1-9 page 9, line 79 - page 10, line 126	1,4,21, 22,25
X	US 5 694 947 A (LEHTINEN ET AL) 9 December 1997 (1997-12-09) the whole document	34-38, 40,41, 43-46,54
	----- -/--	

INTERNATIONAL SEARCH REPORT

International application No
PCT/US2006/017618

C(Continuation). DOCUMENTS CONSIDERED TO BE RELEVANT		
Category*	Citation of document, with indication, where appropriate, of the relevant passages	Relevant to claim No.
A	US 2003/153983 A1 (MILLER KATHLEEN M ET AL) 14 August 2003 (2003-08-14) cited in the application	1-22, 24, 25, 31-54
Y	paragraph [0020] - paragraph [0092]; figures 1-6 -----	5, 23, 26-30, 35, 37, 42, 48-50

INTERNATIONAL SEARCH REPORT

International application No.
PCT/US2006/017618

Box II Observations where certain claims were found unsearchable (Continuation of item 2 of first sheet)

This International Search Report has not been established in respect of certain claims under Article 17(2)(a) for the following reasons:

1. Claims Nos.:
because they relate to subject matter not required to be searched by this Authority, namely:

2. Claims Nos.:
because they relate to parts of the International Application that do not comply with the prescribed requirements to such an extent that no meaningful International Search can be carried out, specifically:

3. Claims Nos.:
because they are dependent claims and are not drafted in accordance with the second and third sentences of Rule 6.4(a).

Box III Observations where unity of invention is lacking (Continuation of item 3 of first sheet)

This International Searching Authority found multiple inventions in this international application, as follows:

see additional sheet

1. As all required additional search fees were timely paid by the applicant, this International Search Report covers all searchable claims.
2. As all searchable claims could be searched without effort justifying an additional fee, this Authority did not invite payment of any additional fee.
3. As only some of the required additional search fees were timely paid by the applicant, this International Search Report covers only those claims for which fees were paid, specifically claims Nos.:

4. No required additional search fees were timely paid by the applicant. Consequently, this International Search Report is restricted to the invention first mentioned in the claims; it is covered by claims Nos.:

Remark on Protest

- The additional search fees were accompanied by the applicant's protest.
- No protest accompanied the payment of additional search fees.

FURTHER INFORMATION CONTINUED FROM PCT/ISA/ 210

This International Searching Authority found multiple (groups of) inventions in this international application, as follows:

1. claims: 1-33

A urological medical device comprising a first therapeutic agent for treating a urological condition, wherein said medical device is adapted, upon implantation or insertion into a patient, to release all or a majority of said first therapeutic agent from a portion of said medical device that occupies the urinary bladder.

1.1. claims: 34-54

A uterine device for treatment of a uterine condition comprising a contoured structure of a flexible material having the general contours of an interior cavity of a human female uterus wherein the device comprises a therapeutic agent for treating a uterine condition.

INTERNATIONAL SEARCH REPORT

Information on patent family members

International application No

PCT/US2006/017618

Patent document cited in search report		Publication date	Patent family member(s)	Publication date			
WO 2004010975	A	05-02-2004	AU 2003261335	A1 16-02-2004			
			CA 2506997	A1 05-02-2004			
			EP 1526879	A2 04-05-2005			
			JP 2006500085	T 05-01-2006			
			US 2004022824	A1 05-02-2004			
			US 2006171895	A1 03-08-2006			
WO 0064513	A	02-11-2000	AU 4483100	A 10-11-2000			
US 6293923	B1	25-09-2001	AT 283673	T 15-12-2004			
			AU 3189100	A 04-10-2000			
			CA 2365447	A1 21-09-2000			
			DE 60016387	D1 05-01-2005			
			DE 60016387	T2 10-11-2005			
			EP 1161199	A1 12-12-2001			
			WO 0054701	A1 21-09-2000			
			JP 2002538888	T 19-11-2002			
			US 2002055730	A1 09-05-2002			
			US 2002082551	A1 27-06-2002			
			EP 0372137	A	13-06-1990	AU 622877	B2 30-04-1992
						AU 2685088	A 02-08-1990
IN 168149	A1 09-02-1991						
US 4871542	A 03-10-1989						
US 2002161352	A1	31-10-2002	CN 1382500	A 04-12-2002			
US 3993057	A	23-11-1976	NONE				
GB 1414812	A	19-11-1975	NONE				
US 5694947	A	09-12-1997	AT 177657	T 15-04-1999			
			AU 674758	B2 09-01-1997			
			AU 6848194	A 17-01-1995			
			BR 9407118	A 03-09-1996			
			CA 2165282	A1 05-01-1995			
			CN 1125403	A 26-06-1996			
			CZ 9503208	A3 17-07-1996			
			DE 69417232	D1 22-04-1999			
			DE 69417232	T2 04-11-1999			
			DK 703802	T3 11-10-1999			
			EE 3202	B1 16-08-1999			
			EP 0703802	A1 03-04-1996			
			ES 2130423	T3 01-07-1999			
			FI 932789	A 18-12-1994			
			WO 9500199	A1 05-01-1995			
			GR 3030565	T3 29-10-1999			
			HU 74548	A2 28-01-1997			
			JP 8511240	T 26-11-1996			
			LT 1957	A 31-01-1995			
			LV 12452	A 20-04-2000			
			NO 955029	A 12-12-1995			
PL 312193	A1 01-04-1996						
RU 2121824	C1 20-11-1998						
US 2003153983	A1	14-08-2003	AU 2003215079	A1 02-09-2003			
			CA 2478787	A1 14-08-2003			
			EP 1476205	A1 17-11-2004			

INTERNATIONAL SEARCH REPORT

Information on patent family members

International application No

PCT/US2006/017618

Patent document cited in search report	Publication date	Patent family member(s)	Publication date
US 2003153983	A1	JP 2005534350 T	17-11-2005
		WO 03066119 A1	14-08-2003
		US 2005161859 A1	28-07-2005
		US 2004249441 A1	09-12-2004
