

M. Loughran.

Spike Machine.

N^o 20,076.

Patented Apr. 27, 1858.

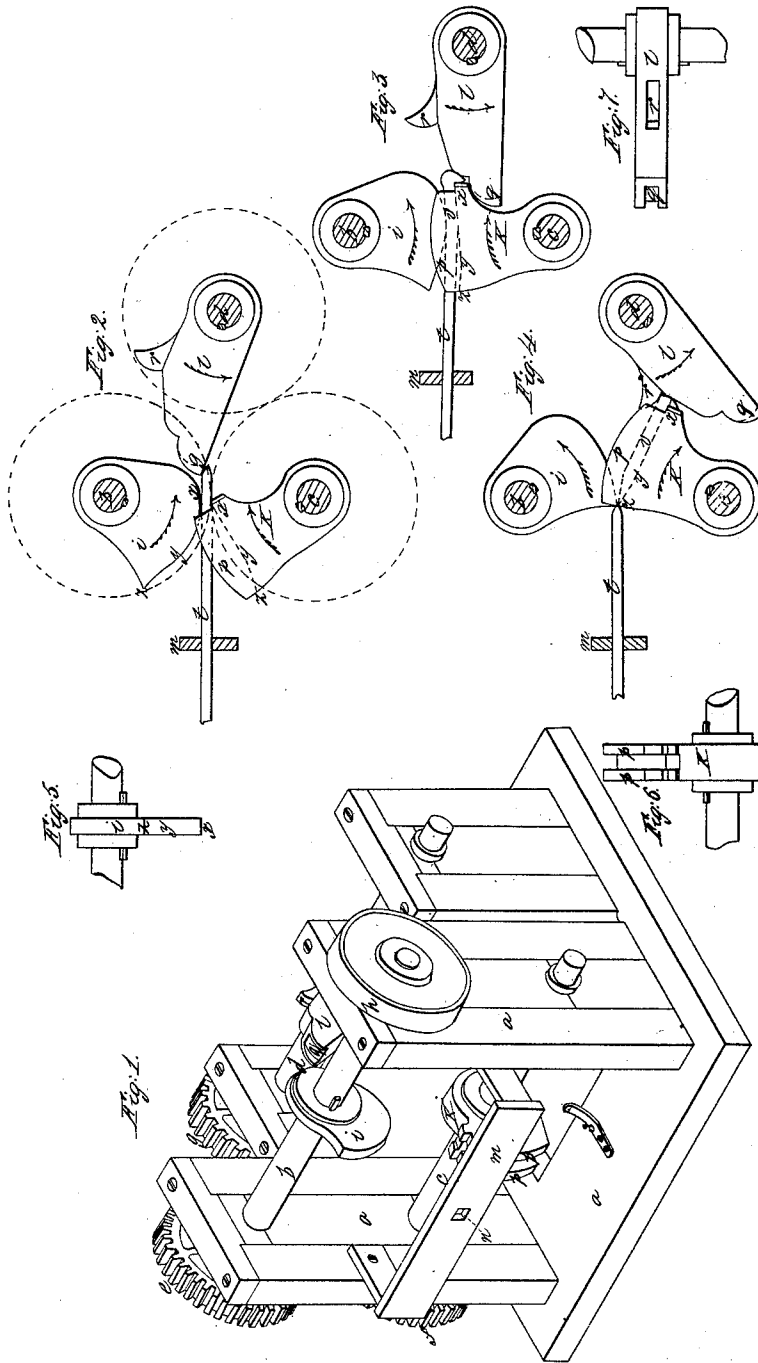

UNITED STATES PATENT OFFICE.

MICHAEL LOUGHRAN, OF PITTSBURG, PENNSYLVANIA.

SPIKE-MACHINE.

Specification of Letters Patent No. 20,076, dated April 27, 1858.

To all whom it may concern:

Be it known that I, MICHAEL LOUGHRAN, of Pittsburg, in the county of Allegheny and State of Pennsylvania, have invented a new and useful Improvement in Machines for Making Spikes; and I do hereby declare the following to be a full, clear, and exact description thereof, reference being had to the annexed drawing, forming part of this specification, in which—

Figure 1, is a perspective view of my machine. Fig. 2, is a side view of the dies, when about to operate on the iron in the formation of a spike. Fig. 3, is a side view of the dies after the head is bent over and before the spike is finished. Fig. 4, represents a side view of the dies when the spike is fully formed and pointed, showing the mode in which it is severed from the bar. Fig. 5, is a front view of the upper die. Fig. 6, is a front view of the lower die. Fig. 7, is a front view of the heading die.

In the several figures like letters of reference denote similar parts of my machine.

My invention consists in the use of dies working as eccentric cams, and of the shape hereinafter described, so combined and arranged as to form a spike at one operation at every single revolution of the dies.

To enable others skilled in the art to construct and use my improved spike machine, I will proceed to describe its construction and operation.

My machine is designed to make what are usually called railroad spikes, made of square iron, with a flat or chisel point, and a head on one side.

In the drawings, Figure 1, is a perspective view of my machine, in which *a* is the frame of my machine, consisting of two side pieces, united by a bed plate; *b*, *c*, and *d* are three shafts, each of which carries one of the dies; the shafts *b* and *c* are so placed that *b* is in a perpendicular line over *c*, and *d* is placed behind *b* and *c*, the axis of the shaft *d* being the same distance from the axis of the shaft *c* that *c* is from *b*. These shafts are connected at one side of the machine by three cog wheels of equal diameter, the cog wheel *e*, on the shaft *b*, gearing into the cogwheel *f*, on the shaft *c*, and the cogwheel *f*, gearing into the cogwheel *g*, on the shaft *d*. These shafts *b*, *c*, and *d* revolve, therefore, with equal velocity. Power is communicated to my machine from some prime mover, by a belt passing over a drum *h* at

the other end of one of these shafts, while to one of the other of the shafts is attached the fly wheel. Each of these shafts carries a die, by which the spike is formed. The shaft *b*, carries the upper die *i*; the shaft *c*, (the axis of which is perpendicularly below the axis of the shaft *b*) carries the lower die *k*, and the shaft *d* carries the heading die *l*. These three dies revolve with their shafts and all in the same plane.

m is the rest through an aperture *n* in which the iron is fed to the dies.

The upper die *i* is shaped like an eccentric cam, and the shape of it, as well as of the other dies will best be seen by the side view given in Figs. 2, 3, and 4. From the point *x* to *y* (see Fig. 2) the upper die *i* is a regular eccentric curve, so that when revolving with the lower die *k* it will roll the iron exactly straight, but from *y* to *z* it is straight, the point *z*, being distant from the axis or center of the die, just half of the thickness of the spike farther than the point *y*, so as to shape the upper half of the point of the spike. The width or thickness of the face of the upper die *i*, is exactly the width or thickness of the spike to be rolled.

The lower die *k*, is of the shape shown in Fig. 2, the shape of the face of the die being shown by dotted lines, the sides *p*, *p* of this die, projecting above the face so as to inclose the sides of the spike, and prevent the pressure between the dies, pressing the iron out laterally. The upper die *i* passes in between the sides *p*, *p*, of the lower die *k*. The face of this lower die *k*, from *x* to *y*, is straight, but from *Y* to *z*, it inclines upward so as to form the one half of the point of the spike, as will be more clearly seen by Fig. 4.

The heading die *l*, is of the shape shown in Figs. 2, 3 and 4, the point *q* of this die is rounded and has a recess (see Fig. 1) so that in turning over the head of the spike, the side of the head may be made smooth and square: The horn *r* on the upper edge of the heading die *l* is designed to press down the shoulder formed by the first action of the heading die in turning over the iron, and giving the proper shape and finish to the head, and is so situated on the heading die *l* that it acts on the head of the spike just as the lower and lower dies are pointing the spike, and severing it from the bar of iron of which it was made, as will be seen in Fig. 4.

On the bed plate *a* of the machine, in the

same plane in which the dies revolve is a leaf spring *s*, the point of which is slightly hooked, and which as the lower die revolves with the finished spike between its side pieces *p*, *p* touches the head of the spike and delivers it from the die.

Having thus described the several parts of my machine I will proceed to describe its operation.

My machine is designed to make spikes from long bars or rods of squared iron, just as they pass from the mill, in which the iron is rolled. Being then at a red heat, not too cold to be readily worked into shape by the dies, and not too hot to retain the shape given to it, the long bars of iron are cut up and formed into spikes as rapidly as they can be fed into my machine or made by the rolling mill.

A rod of iron, being usually about thirty feet long, will make about fifty five six-inch spikes in as many revolutions of my machine.

The bar of iron is inserted through the hole *n* in the rest *m*, (see Fig. 1,) is caught between the upper die *i* and lower die *k*, and carried forward between them as they revolve. The bar of iron (marked *t* in Figs. 2, 3 and 4,) is now in the position relatively to the dies, shown in Fig. 2. As the dies *i* and *k* revolve, they press the iron between their faces, and the side pieces *p*, *p*, of the lower die *k* from *x* to *y* making it straight and square at *y* and thence, toward 2, the thickness of the iron between the faces of the dies *i* and *k* is gradually diminished, until the heel *z* of the dies *i* and *k* come together and touch as at Fig. 4, when the iron in the dies is severed from the bar and the spike *v* has a sharp point given to it. As the dies *i* and *k* pass around (in the direction indicated by the arrows) from the position shown in Fig. 2 to that represented in Fig. 3, the point *q* of the heading die *l*, passes over the extremity of the iron bar which projects from the dies *i* and *k*, and turns it over as seen in Fig. 3, the head passing into

and being formed by the recess in the end of the die *l*. This is done (see Fig. 3,) while the body of the spike is being pressed, and makes a shoulder in the spike just back of the head. Meanwhile as the dies *i* and *k* pass around to the position shown in Fig. 4, the face of the heading die *l* from the point of the die *l* which touches the spike in Fig. 3, to the base of the horn *r* rubs over the head of the spike, shaping it properly. The horn *r* then presses against the shoulder formed back of the head of the spike and flattens down the shoulder leaving the back of the spike at its upper end straight and smooth as seen in Fig. 4. At this point in the revolution of the dies the heel of the dies *i* and *k* have come in contact with each other, and therefore have pointed and severed the spike from the bar of iron. The spike is still retained between the sides *p*, *p*, of the lower die *k*, but as this die passes around, the spring *s* catches the head of the spike and delivers it from the die *k*, whence it falls to the ground. The bar of iron remains in the position shown in Fig. 4, until the next revolution of the dies *i* and *k* catches, and draws it forward, forming a spike in like manner; and this process is repeated without any necessity of feeding in, until the whole bar is cut up into spikes, by the machine.

Having thus described my improvement in spike machines, what I claim as my invention and desire to secure by Letters Patent is—

The employment of dies *i*, *k*, and *l*, constructed arranged and operated as specified, working on separate shafts and forming spikes at a single revolution.

In testimony whereof I have hereunto set my hand this thirtieth day of March A. D. 1858.

MICHAEL LOUGHRAN.

Witnesses:

MARTIN G. CURLING,
W. DUDLEY KING.