

(No Model.)

2 Sheets—Sheet 1.

C. W. BAIRD.  
HAY RAKE AND LOADER.

No. 508,397.

Patented Nov. 14, 1893.

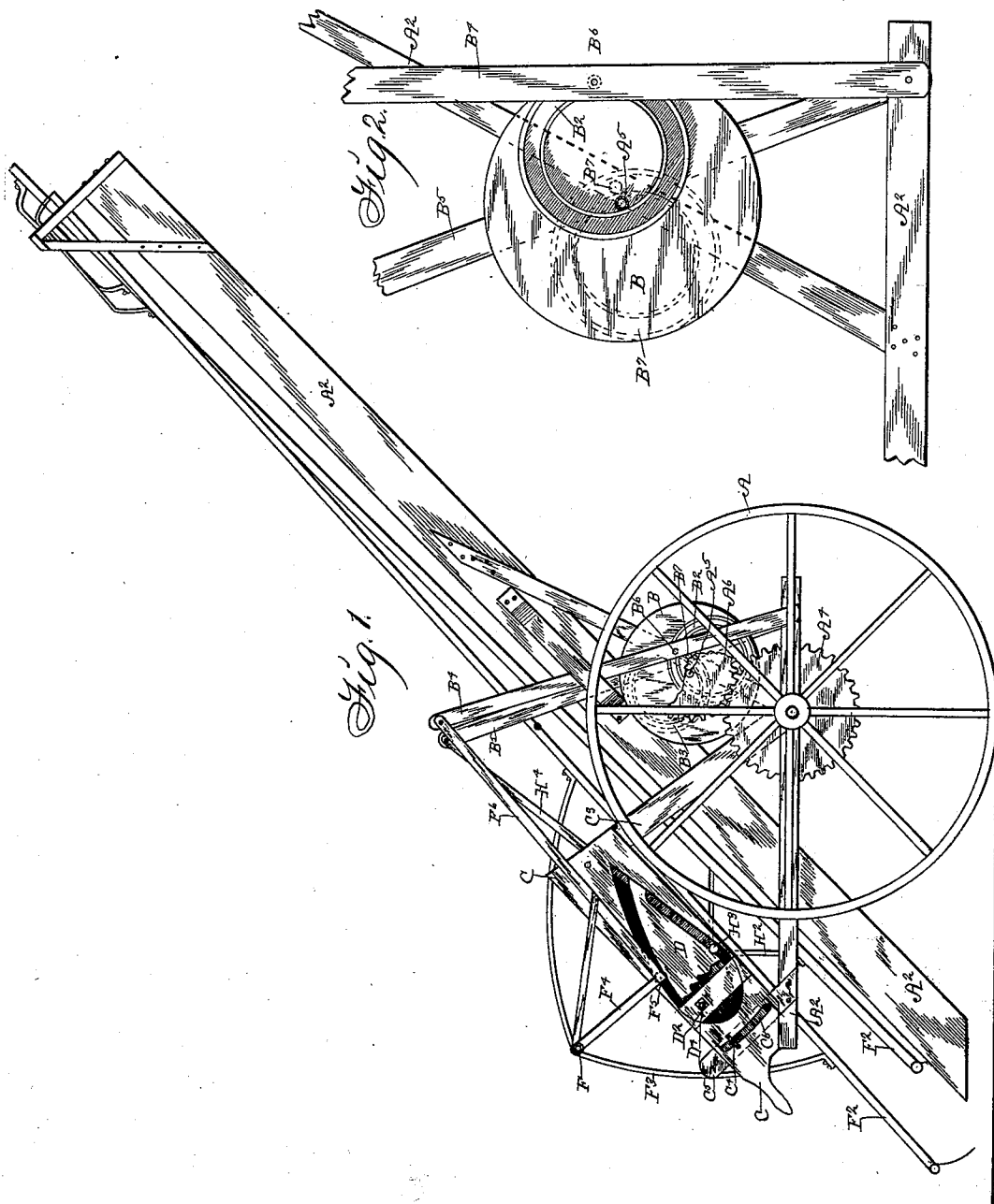

Witnesses:  
 J. Ralph Orwig,  
 A. H. Orwig

Inventor: Charles W. Baird,  
 By Thomas G. Orwig, Atty.

C. W. BAIRD.  
HAY RAKE AND LOADER.

No. 508,397.

Patented Nov. 14, 1893.

*Fig. 3.*

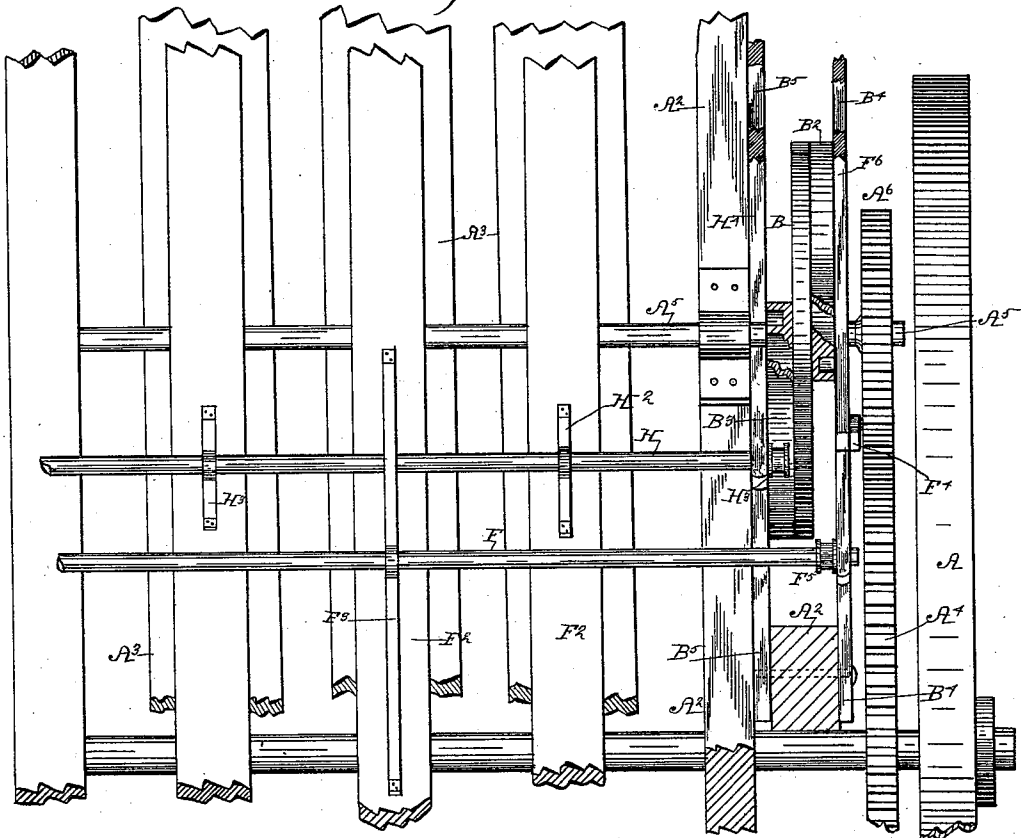

*Fig. 4.*

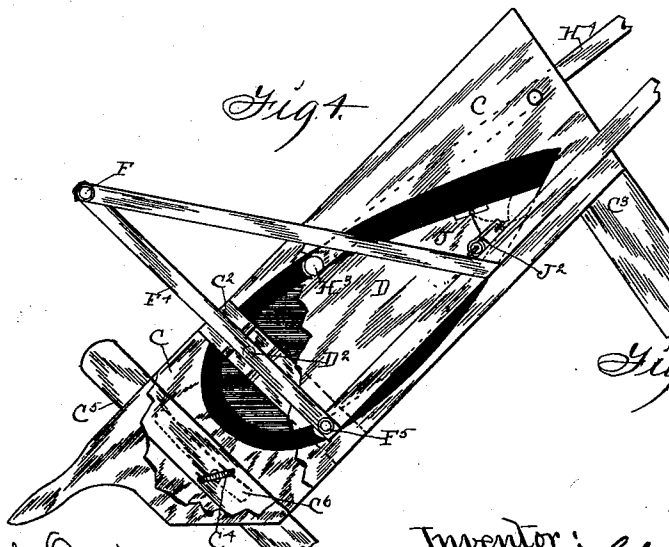

*Fig. 5.*

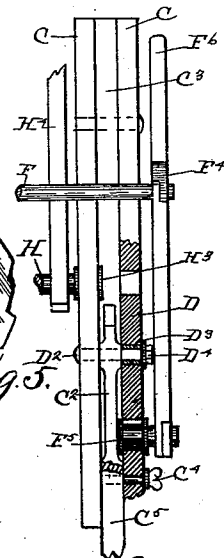

J. Ralph Orwig.  
R. H. Orwig. } Witnesses.

Inventor: Charles W. Baird,  
By Thomas G. Orwig, Atty.

# UNITED STATES PATENT OFFICE.

CHARLES W. BAIRD, OF MILLERSBURG, IOWA.

## HAY RAKE AND LOADER.

SPECIFICATION forming part of Letters Patent No. 508,397, dated November 14, 1893.

Application filed April 10, 1893. Serial No. 469,692. (No model.)

*To all whom it may concern:*

Be it known that I, CHARLES W. BAIRD, a citizen of the United States of America, residing at Millersburg, in the county of Iowa and State of Iowa, have invented an Improved Hay Rake and Loader, of which the following is a specification.

The objects of my invention are, broadly, to dispense with the expensive sprocket gears and crank shafts heretofore employed in transmitting motion from the traction wheels to the elevator bars, and to substitute therefor mechanism which will be cheap, simple, durable and operated with a minimum of power, and so arranged that any desirable movement may be given to the lower end portion of the elevator bars so that all of the power may be used to the best possible advantage.

With these ends in view my invention consists first in the construction of a device for imparting an alternately reciprocating motion to two levers, from the traction wheels of the device.

My invention consists further in the construction of mechanism whereby the alternate elevator bars are connected with the said levers to be operated thereby and an approximately elliptical stroke imparted thereto.

My invention consists further in certain other minor details of construction, arrangement and combination of parts as hereinafter set forth, pointed out in my claims, and illustrated in the accompanying drawings, in which—

Figure 1 is a side elevation of the complete rake and loader. Fig. 2 is an enlarged detail side view of the mechanism for imparting an alternately reciprocating motion to the two levers. Fig. 3 is an enlarged, rear view of a portion of the elevator frame, showing the mechanism for imparting an alternately reciprocating motion to the two levers, and connective parts. Fig. 4 is an enlarged detail side view of the mechanism for imparting an approximately elliptical motion to the elevator bars, parts being broken away to reveal hidden portions and Fig. 4 is a rear, edge view of the same.

Referring to the accompanying drawings, the reference letter A is used to designate

the traction wheels, and A<sup>2</sup> the supporting frame, which has a slotted bottom A<sup>3</sup> all of the ordinary construction.

The mechanism for imparting motion to the elevator bars is similar, on each side of the machine, so that but one side will be hereinafter described.

A<sup>4</sup> designates a cog wheel fixed to the axle of the traction wheels of the device.

A<sup>5</sup> is a shaft mounted in suitable bearings fixed to a portion of the supporting frame and extended transversely of the device.

A<sup>6</sup> is a cog wheel fixed to its outer end and in mesh with the wheel A<sup>4</sup>.

B designates a wheel fixed to the same shaft, and having formed on its opposite sides the annular grooves B<sup>2</sup> and B<sup>3</sup>. These grooves are preferably formed by means of two concentric circular walls projecting laterally from the sides of the wheel, and are preferably of such a size that the grooves will extend from a point in proximity to the center of the wheel B to the outer edge of the other side of the center.

B<sup>4</sup> and B<sup>5</sup> are levers fulcrumed at their lower ends to a suitable portion of the frame and extended in close proximity to the opposite side of the wheel B.

B<sup>6</sup> is an anti-friction roller, mounted upon a bolt fixed to the lever B<sup>4</sup> to enter the annular groove B<sup>2</sup> and B<sup>7</sup> is a like roller connected with the lever B<sup>5</sup> to work in the groove B<sup>3</sup>. It will thus be seen that a rotation of the wheel B will impart an alternately reciprocating motion to the levers B<sup>4</sup> and B<sup>5</sup> by causing the anti-friction rollers B<sup>6</sup> and B<sup>7</sup> to engage the sides of the annular grooves B<sup>2</sup> and B<sup>3</sup> said grooves being of such a size, that, as the rollers pass from the outer portion of the wheel B toward the central portion thereof, the said groove will have changed its position relative to the roller and wheel B as to allow the levers to swing in a vertical plane from their pivotal point on the frame and the rollers be in a position in advance of the central portion of the wheel B at all times, as clearly shown in Figs. 1 and 2.

C designates a frame composed of two flat pieces of wood separated by means of a block C<sup>3</sup> and placed in a position approximately

parallel with the frame  $A^2$  and pivotally mounted at the upper end portion on the support  $C^3$  which is fixed to the frame. The lower end portion of this frame  $C$  is made capable of a slight vertical adjustment for purposes hereinafter set forth, by means of the set screw  $C^4$  extended through the support  $C^5$  and working in slots  $C^6$  formed in the side pieces of the frame. In the central portion of each of the side pieces of this frame  $C$  is a block  $D$ , approximately elliptical in shape and pivotally mounted near its rear upper portion upon the pivot  $D^2$  and capable of a slight movement in a vertical plane. Its lower forward end portion normally rests upon the bottom side of the opening formed in the side piece of the frame  $C$ .

$D^3$  is a sleeve encircling the pivot  $D^2$  where it engages block  $D$  and  $D^4$  is a nut upon one end of said pivot. By removing the sleeve  $D^3$  and tightening the nut  $D^4$  the block  $D$  may be held rigid for purposes hereinafter explained.

$F$  designates a bar extended transversely of the machine and connected with each alternate elevator bar  $F^2$  (which bars have a sliding connection with the elevator frame at their upper end portions) by means of a brace  $F^3$ . This bar is extended above and beyond the side of the frame  $C$ , and a support  $F^4$  depends from its outer end and has a flanged antifriction roller  $F^5$  fixed to its end to enter the space between the outer elliptical block and the edges of the opening in the outer side piece of the frame  $C$ , with its flanges overlapping said parts, and  $F^6$  is a bar connecting said support  $F^4$  with the upper end of the lever  $B^4$ .

$H$  designates a bar similar to the bar  $F$  and connected with the remaining elevator bars by the braces  $H^2$ , and having a flanged antifriction roller  $H^3$  connected directly with its end to enter the space between the inner elliptical block and the edges of the opening in the inner side piece of the frame  $C$ . This bar is connected with the lever  $B^5$  by means of a bar  $H^4$ . It will now be obvious that the straight reciprocating motion of the levers  $B^4$  and  $B^5$  will transmit a motion to the elevator bars corresponding with the shape of the block  $D$  (which in the present instance is approximately elliptical) for the reason that the rollers will travel around said block when motion is imparted to them by the levers. As the said roller reaches the forward end of the block it will elevate the same and when it has passed beyond the block said block will fall and compel the roller to return on the top edges thereof. The brackets that support the bar  $F$  are of such a length that the bar  $H$  may perform its movement wholly beneath it, so that they will not interfere with each other and if it is desirable to change the position of the stroke of the elevator bars, that is, relative to the slatted bottom of the frame the frame  $C$  may be swung vertically

on its pivot and adjusted to any height by the set screw  $C^4$ .

If desirable, the elliptical blocks may be permanently fixed and their forward end portions hinged at  $J$  in the manner shown in Fig. 4 so that only said hinged portion will be elevated by the roller, as indicated by dotted lines in the same figure.  $J^2$  is a hook by which said hinged portion may be secured to the block  $C^2$  so that the whole block will move in the manner first described, so that these parts may be used interchangeably.

I do not desire to be understood as limiting myself to the particular shape of the blocks  $C^2$  nor to the combination of the particular manner of imparting an alternately reciprocating motion to the levers  $D^3$  and  $D^4$  and the particular manner of imparting motion to the elevator bars.

What I claim as my invention, and desire to secure by Letters Patent of the United States therefor, is—

1. In a hay rake and loader mechanism for imparting an alternately reciprocating motion, from the traction wheels, to the elevator bars, comprising the following elements, in combination to wit; a rotatable shaft geared to the traction wheels to be operated thereby, a wheel  $B$  fixed to said shaft and having the annular grooves  $B^2$  and  $B^3$  formed thereon, levers  $B^4$  and  $B^5$  pivotally mounted in a suitable portion of the machine frame and having the anti-friction rollers  $B^6$  and  $B^7$  connected therewith and placed in the said grooves, cross bars connected with the alternate elevator bars and bars connecting said cross bars with the said levers, to operate in the manner set forth.

2. In a hay rake and loader, mechanism for imparting an approximately elliptical motion to two sets of elevator bars, in opposite directions, comprising the following elements in combination, to wit, two flat boards secured to the elevator frame near its lower end portion, an approximately elliptical block pivotally mounted in an opening in each board, to swing in a vertical plane, a roller interposed between the block and the edges of the opening in each board, a bar connected with the alternate elevator bars and with one of said rollers and a like bar connected with the remaining elevator bars and the remaining roller and mechanism deriving its motion from the traction wheels of the device to alternately reciprocate the said rollers, to operate in the manner set forth.

3. In a hay rake and loader, mechanism for imparting an approximately elliptical motion to two sets of elevator bars, in opposite directions, comprising the following elements, in combination, to wit; a frame  $C$  composed of two flat side pieces, separated by the block  $C^2$  mounted on part of the machine frame, an approximately elliptical block  $D$  in an opening in each side piece, pivoted at its rear end portion to swing in a vertical plane with its

forward end normally resting upon the bottom of said opening as set forth, a cross bar F connected with each alternate elevator bar by means of the braces F<sup>3</sup> and having a bracket F<sup>4</sup> depending from its outer end to support a flanged roller F<sup>5</sup> in the space between the edges of the outer elliptical block and the edges of the opening in the outer side piece of the frame C, a like cross bar H connected with the remaining elevator bars by means of the braces H<sup>2</sup>, a roller H<sup>3</sup> in its end to enter the space between the inner elliptical block and the edges of the opening in the inner side piece of the frame C to operate in the manner set forth, and means for imparting an alternately reciprocating motion to the said rollers.

4. In a hay rake and loader mechanism for imparting an approximately elliptical motion to two sets of elevator bars in opposite directions comprising the following elements in combination, to wit, a frame C composed of two flat side pieces separated by the block C<sup>2</sup> and pivotally mounted at its forward end to a suitable portion of the frame and having a set screw C<sup>4</sup> to provide means whereby the rear end may be vertically adjusted for the purposes stated, an approximately elliptical block D in an opening in each side piece, pivoted at its rear end portion, to swing in a vertical plane, with its forward end normally resting upon the bottom of said opening, as set forth, a cross bar F, connected with each alternate elevator bar by means of the braces F<sup>3</sup> and having a bracket F<sup>4</sup> depending from its outer end, to support a flanged roller F<sup>5</sup>, in the space between the edges of the outer elliptical block and the edge of the opening in its outer side piece of the frame C, a like cross bar H connected with the remaining elevator bars by means of the braces H<sup>2</sup>, a roller H<sup>3</sup> on its end to enter the space between the inner elliptical block and the edges of the opening in the inner side piece of the frame C, to operate in

the manner set forth, and means for imparting an alternately reciprocating motion to the said roller.

5. In a hay rake and loader the combination of the following elements to wit; a flat board having an approximately elliptical opening therein, a block D mounted in a pivot D<sup>2</sup>, a sleeve D<sup>3</sup> interposed between the pivot and block and a nut D<sup>4</sup> on the end of said pivot, the forward section of said block hinged to the remainder thereof at J, and a hook J<sup>2</sup> whereby said sections may be secured together for the purposes stated.

6. An improved hay rake and loader comprising the following elements, arranged and combined as set forth, for the purposes stated, the traction wheels A the frame A<sup>2</sup> mounted thereon and having the slatted bottom A<sup>3</sup>, mechanism at each side of the machine for operating the elevator bars, comprising the cog wheel A<sup>4</sup>, a shaft A<sup>5</sup> extended transversely of the machine a cog wheel A<sup>6</sup> on each end thereof a wheel B having the annular grooves B<sup>2</sup> and B<sup>3</sup>, the levers B<sup>4</sup> and B<sup>5</sup> the anti-friction rollers B<sup>6</sup> and B<sup>7</sup> the frame C composed of flat side pieces as set forth separated by the block C<sup>2</sup>, and pivotally mounted on the supports C<sup>3</sup> the set screw C<sup>4</sup> extended through the upright C<sup>5</sup> and slots C<sup>6</sup> the blocks D mounted on the pivots D<sup>2</sup>, the sleeve D<sup>3</sup> and nuts D<sup>4</sup>, the cross bar F, connected with the alternate elevator bars F<sup>2</sup>, means whereby said bars have their upper ends slidingly connected with the elevator frame, the bracket F<sup>4</sup> having the flanged roller F<sup>5</sup> on its lower end, the bar F<sup>6</sup> the cross bar H, the braces H<sup>2</sup>, and flanged roller H<sup>3</sup> and the sections of the blocks D hinged at J and held in position by the hook J<sup>2</sup> to operate in the manner set forth.

CHARLES W. BAIRD.

Witnesses:

H. L. MCBRIDE,  
JOHN V. HATTER.