

A. AMREIN.
 APPARATUS FOR DYEING.
 APPLICATION FILED JUNE 11, 1909.

997,360.

Patented July 11, 1911.

2 SHEETS—SHEET 1.

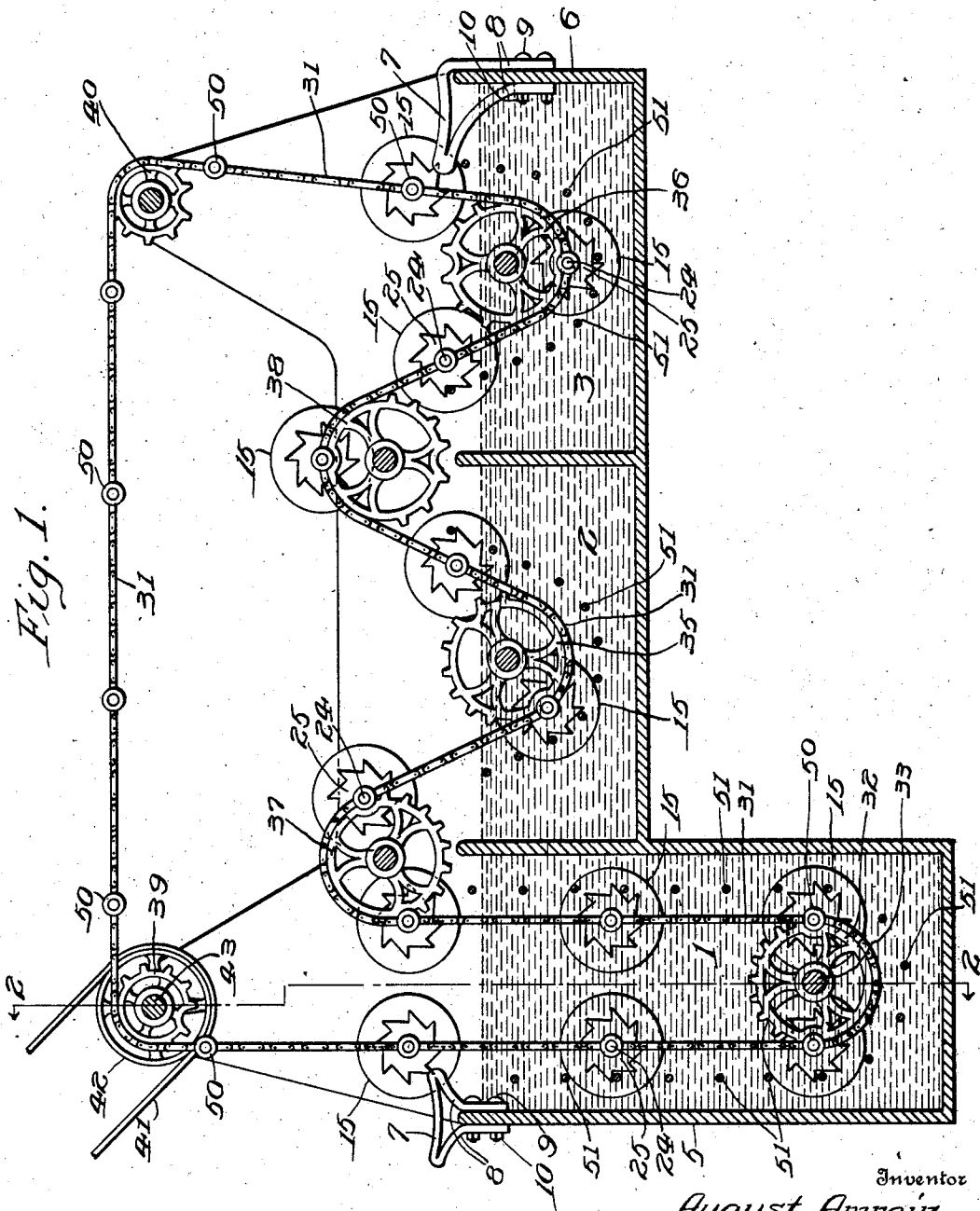

Fig. 1.

Witnesses
 Daniel Webster, Jr.
 Maurice J. Wall.

Inventor
 August Amrein.
 Home City.
 Attorney

A. AMREIN.
 APPARATUS FOR DYEING.
 APPLICATION FILED JUNE 11, 1909.

997,360.

Patented July 11, 1911.

2 SHEETS—SHEET 2.

Fig. 3.

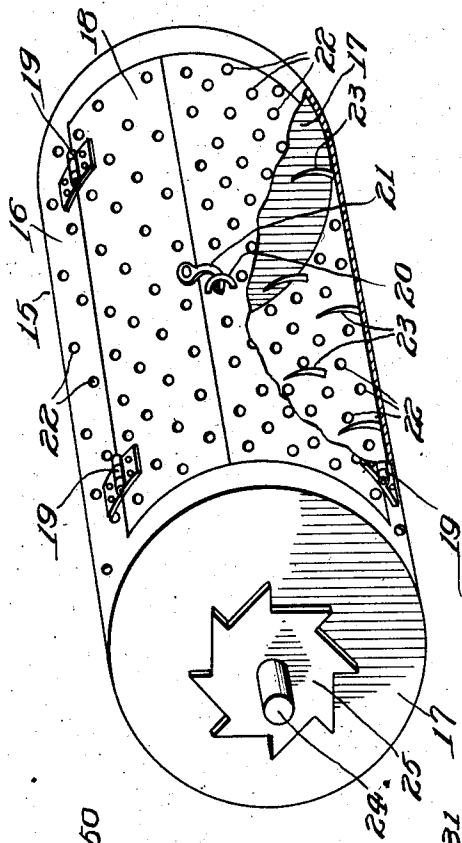

Fig. 4.

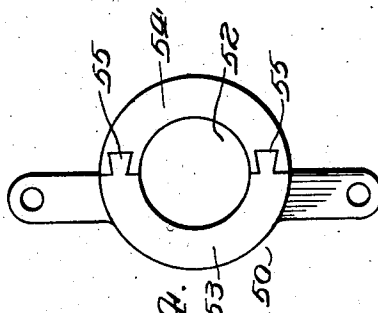
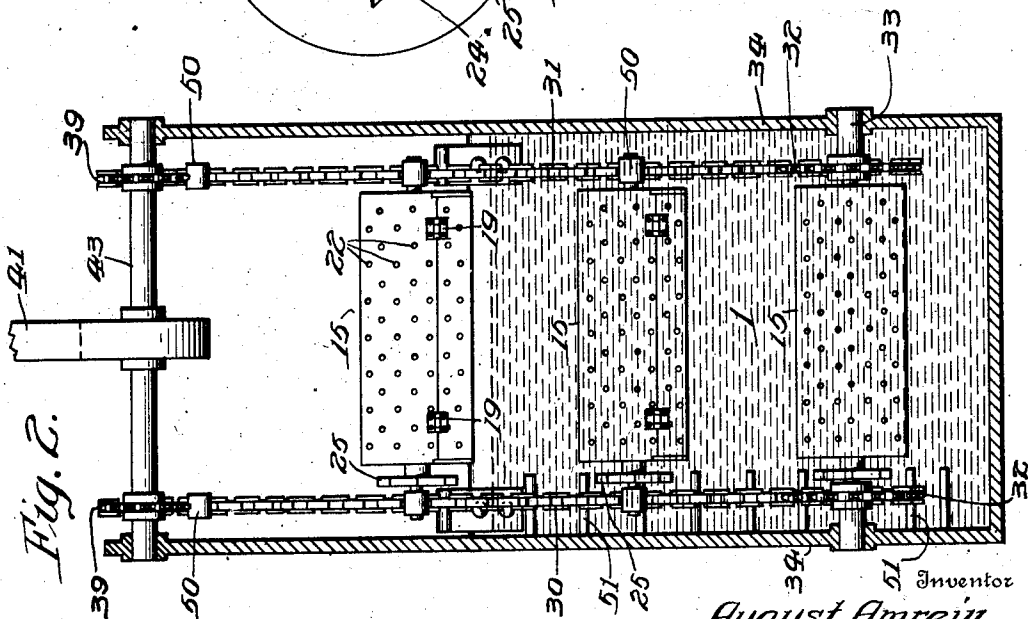

Fig. 5.



Inventor
August Amrein.

Witnesses
Daniel Webster, Jr.
Maurice J. Wall.

H. M. Tetzl.

Attorney

UNITED STATES PATENT OFFICE.

AUGUST AMREIN, OF PHILADELPHIA, PENNSYLVANIA.

APPARATUS FOR DYEING.

997,360.

Specification of Letters Patent. Patented July 11, 1911.

Application filed June 11, 1909. Serial No. 501,463.

To all whom it may concern:

Be it known that I, AUGUST AMREIN, a citizen of Switzerland, and a resident of the city and county of Philadelphia, State of Pennsylvania, have invented certain new and useful Improvements in Apparatus for Dyeing, of which the following is a full, clear, and complete disclosure.

This invention relates to the art of dyeing, and more especially to that branch of the art which embraces the dyeing of raw material, such as cotton, wool, and the like, in loose form.

The objects of my invention are to provide a method and apparatus in which all the steps of the dyeing process, including the washing of the dyed stock, is carried on automatically, and the dyeing proper is accomplished without removing the stock from the dyeing bath or liquor.

My invention is especially applicable to the dyeing of vat colors, such as direct, sulfur, acid and chrome colors, and other colors which are liable to be oxidized by being frequently brought into contact with the air while being subjected to the dyeing liquor.

With these and other objects in view, my invention consists of the method hereinafter described and claimed, and the combination and arrangement of parts in the apparatus hereinafter described, illustrated in the accompanying drawings and specifically pointed out in the appended claims.

In the drawings, Figure 1 is a view partly in vertical section and partly in elevation of my improved apparatus. Fig. 2 is a transverse vertical section on the line 2-2 of Fig. 1. Fig. 3 is a perspective view of a container for holding the stock. Fig. 4 is a view of a detail.

In carrying out this improved method, I make use of a series of vats or tanks, 1, 2 and 3, which may be made of wood or metal as desired. The vat 1 contains the dye liquor. Its depth may be made much greater than its width, in order to provide a comparatively small surface exposed to the air for a given amount of the liquor.

The vats 2 and 3 are provided with the washing liquid. Ordinarily only two are used, but it is obvious that as many may be used as it is thought expedient or desirable to use. These vats are arranged in successive relation to each other, with their top portions on a level with each other.

Brackets or shelves are erected at the top of the side 5 of the vat or tank 1 and the side 6 of the vat or tank 3. These brackets or shelves consist of supporting portions 7 and arms 8, which straddle the sides of the vats or tanks and are attached to the same by means of bolts 9 and nuts 10.

The holder or carrier 15 is adapted to carry the loose material to be dyed. This holder is in the form of a closed receptacle, which may be cylindrical in form, as shown, and is composed of the side portion 16 and the ends 17. The side portion 16 is provided with a closure which may comprise the doors 18, hinged as at 19, and furnished with suitable means for holding the same closed, as the eye 20 and the hook 21. The side portion 16 may also be provided with the perforations 22, to permit the dyeing and washing liquors to pass through the same and permeate the stock. It is obvious that similar perforations may be made in the ends 17, if desired. For the purpose of agitating the mass of stock, the inside of the walls of the receptacle 15 is provided with the pins or teeth 23, which may be curved as shown. The ends of the receptacle 15 have the trunnions 24 projecting outwardly from their central portions, and the ratchet wheels 25 arranged concentrically with the same, for a purpose hereinafter disclosed. These means consist of a pair of parallel endless chains 30 and 31, between which the receptacle 15 is mounted. A pair of sprocket wheels 32, mounted on the shaft 33, are suitably mounted to rotate in the vat 1. The shaft 33 may be journaled in the ends 34 of the vat 1, as shown, or any other means may be used for the purpose. The wheels 35 and 36 are similarly arranged in the vats or tanks 2 and 3, respectively. Between the tanks and above the same are also

arranged the similar wheels 37 and 38. The wheels 39 and 40 are suitably mounted to rotate above the tanks 1 and 3, respectively. The chains 30 and 31 pass alternately under and over the wheels 32, 37, 35, 38 and 36, and over the wheels 39 and 40. Any suitable means for applying motive power to the carrier may be used. In this instance there is shown a belt 41 and a pulley 42 attached to the shaft 43, upon which are mounted the wheels 39.

In practicing my improved method, I first place the raw material in the receptacle 15. This receptacle is then placed on the brackets or shelves 7. Certain of the links in the chains 30 and 31 are provided with the eyes 50. The trunnions 24 of the receptacle 15 are inserted in opposite eyes and the receptacle is thereby supported upon the carrier. The end walls 34 of the vats are provided with the projecting pins 51. These pins are so arranged that the teeth of the ratchet wheels 25 strike the same as the receptacle 15 is carried along on the carrier, and a certain intermittent rotary motion is given to the receptacle. It will be noted that the pins 51 are placed closer together in the tanks 2 and 3, as it is found desirable to rotate the receptacles more frequently in the washing bath than in the dye liquor.

It is evident, that the relatively frequent rotation of the receptacles in the washing baths will much more completely remove surplus dyeing fluid from the material within said receptacles than the slower rotation and consequently milder agitation formerly employed.

The speed of the carrier is so regulated that it may be driven continuously, and at the same time the receptacle may be left a sufficient time in the dye liquor and the washing baths. After the receptacle has passed through the tank 3, it is removed from the carrier, and in this connection the shelves 7 may be used to support the same temporarily. It has been found in practice that good results are obtained by having the depth of the tank 1 of such a size that it will take about a half hour for the receptacle to pass through the same, and the depths of the other tanks are also arranged so that it will take about the same time for the receptacle to pass through the washing bath, the speed of the carrier being properly regulated. The whole process would therefore consume about one hour in practice.

In Fig. 4 I have shown a special form of link to be used in the chains 30 and 31. This link is provided with the eye 52, which is composed of two independent portions 53 and 54. The portion 54 has a dovetailed connection, as shown at 55, with the portion 53. This portion 54 may therefore be separated from the portion 53 by a sliding

movement. In practice the portion 54 is removed, the trunnion 24 is then inserted in the eyes, and the portion 54 is replaced. In using this form of eye it would therefore not be necessary to spring the chains 30 and 31 apart.

In my method it will be noted that the material is completely treated with the dye liquor without being exposed to the action of the air. It is also at the same time agitated so that some portions of the material may not be exposed to a greater extent than others to the action of the dye liquor.

In practice I fill the vat 1 with the dye liquor, and as the same gets weaker I replenish it from time to time with fresh dye to keep it at a uniform standard. I also may furnish the vats with steam pipes and heat the liquids therein to maintain the temperature of the same at any desired degree. The liquids in the washing vats are drawn off, as they become contaminated with the dye liquor, and the vats 2 and 3 are filled with a fresh supply of the washing liquid.

The above described form is the preferred form of my apparatus, but it is obvious that many changes may be made therein without departing from the spirit and scope of my invention.

Having now fully described my invention, what I claim and desire to secure by Letters Patent of the United States, is:

1. In an apparatus for dyeing, the combination of a plurality of dyeing and washing tanks, a carrier therein, receptacles rotatively mounted on said carrier, wheels on said receptacles, and means for engaging said wheels to rotate said receptacles at a relatively greater frequency in said washing tanks.

2. In an apparatus for dyeing, a closed receptacle for the material to be dyed, provided with means for agitating said material, comprising rearwardly curved pins.

3. In an apparatus for dyeing, the combination of a series of dyeing and washing tanks, a receptacle, an endless carrier supporting said receptacle and arranged to pass successively through said tanks and variably spaced means progressed by said carrier arranged to revolve said receptacle at a relatively greater frequency in said washing tanks.

4. In an apparatus for dyeing, the combination of a dyeing vat and a plurality of washing vats, an endless carrier arranged to pass successively through said vats, a receptacle rotatively mounted on said carrier, and means in said tanks for intermittently rotating said receptacle, said means in said washing vats being arranged to similarly rotate said receptacle at more frequent intervals than the means in said dyeing vat.

5. In an apparatus for dyeing, a receptacle, a series of dyeing and washing tanks,

means for conveying said receptacle through and between said tanks, means arranged to intermittently rotate said receptacle within said tanks and at a greater
5 speed in said washing tank than in said dyeing tank, and rearwardly curved hooks within each of said tanks for agitating material placed therein.

In witness whereof, I have hereunto set my hand this 8th day of June, A. D. 1909. 10

AUGUST AMREIN.

Witnesses:

MAURICE J. WALL,
ALEXANDER PARK.

Copies of this patent may be obtained for five cents each, by addressing the "Commissioner of Patents, Washington, D. C."
