

(19)



(11)

**EP 1 589 606 B1**

(12)

**EUROPEAN PATENT SPECIFICATION**

(45) Date of publication and mention of the grant of the patent:  
**19.09.2018 Bulletin 2018/38**

(51) Int Cl.:  
**H01Q 1/12** <sup>(2006.01)</sup>      **H01Q 5/385** <sup>(2015.01)</sup>  
**H01Q 5/378** <sup>(2015.01)</sup>      **H01Q 1/36** <sup>(2006.01)</sup>

(21) Application number: **04026430.1**

(22) Date of filing: **08.11.2004**

**(54) A passive wirelike structure for increasing the gain of a window antenna**

Passive Drahtstruktur zur Erhöhung der Verstärkung einer Fensterantenne

Une structure filaire passive pour augmenter le gain d'une antenne sur une fenêtre

(84) Designated Contracting States:  
**AT BE BG CH CY CZ DE DK EE ES FI FR GB GR HU IE IS IT LI LU MC NL PL PT RO SE SI SK TR**

(30) Priority: **22.04.2004 IT RE20040037**

(43) Date of publication of application:  
**26.10.2005 Bulletin 2005/43**

(73) Proprietor: **ASK INDUSTRIES SOCIETÀ PER AZIONI**  
**60037 Monte San Vito (AN) (IT)**

(72) Inventors:  
 • **Cerretelli, Matteo**  
**50019 Sesto Fiorentino (Firenze) (IT)**

• **Giere, Andre**  
**64297 Darmstadt (DE)**

(74) Representative: **Baldi, Claudio et al**  
**Ing. Claudio Baldi S.r.l.**  
**Viale Cavallotti 13**  
**P.O. Box 187**  
**60035 Jesi (AN) (IT)**

(56) References cited:  
**US-A1- 2004 008 144 US-A1- 2004 012 537**

• **PATENT ABSTRACTS OF JAPAN vol. 1998, no. 11, 30 September 1998 (1998-09-30) & JP 10 163727 A (ASAHI GLASS CO LTD), 19 June 1998 (1998-06-19)**

**EP 1 589 606 B1**

Note: Within nine months of the publication of the mention of the grant of the European patent in the European Patent Bulletin, any person may give notice to the European Patent Office of opposition to that patent, in accordance with the Implementing Regulations. Notice of opposition shall not be deemed to have been filed until the opposition fee has been paid. (Art. 99(1) European Patent Convention).

**Description**

## FIELD OF THE INVENTION

**[0001]** The present invention relates to a passive wirelike structure for increasing the gain of a window antenna for automotive vehicles.

**[0002]** More particularly the present invention relates to a passive wirelike structure for increasing the gain of a window antenna for automotive vehicles, particularly suitable for antennas integrated on small windows, such as a side window glass, or on a small portion of large windows such as some no-metalized zones of the windscreen having thin metalization.

**[0003]** The passive wirelike structure having metallic segments of the present invention, allows to integrate an AM-FM reception antenna on available free spaces having dimensions smaller than those necessary for other embodiments. This is due to the fact that the solution of the present invention is able to reduce, for the frequencies relative to the FM reception, the negative influence generally carried out by the surrounding metal body on the antenna gain.

## DESCRIPTION OF THE PRIOR ART

**[0004]** U.S. Patent No. 5,510,804 discloses an antenna based upon a dipole configuration and so typically it requires more available space to be performed than an equivalent monopole antenna. Moreover, the shape of the antenna in said patent is not optimized for reducing the space requirements. So it is not suitable for being implemented as an FM antenna in small glasses but it is particularly applicable for a passive remote entry system.

**[0005]** U.S. Patent Nos. 5,905,470 and 6,437,749 disclose an antenna for AM and FM reception suitable for being attached to a vehicle side window glass and characterised by an S-shaped pattern. In U.S.

**[0006]** Patent No. 5,905,470 the problem of the effects of the vehicle body on antenna gain is marginally covered and it is explained that such an antenna is to be conformed to the window shape on which it is applied so that some parts of the antenna itself are disposed along the peripheral edges of the window glass. In this way the reception gain is not lowered by the influence of the vehicle metal body. However, the degree of freedom in the definition and optimisation of the antenna is very limited.

**[0007]** Moreover, the antennas described in U.S. Patent Nos. 5,905,470 and No. 6,437,749 are realized on a window glass significantly greater (surface more than 3 times) than those where the antenna of this present invention related to and for which is particularly useful. In fact in U.S. Patent No. 5,905,470 the glass having a length of 630mm and an height of 430-450mm is disclosed; while, the structure given as an example in the present invention is realized on a window having: 410mm height and from 140mm (top) to 260mm (bottom) wide.

**[0008]** By reducing significantly glass dimensions the

negative effect of the vehicle metal body on the antenna gain becomes greater and is evident without using shrewdness.

**[0009]** U.S. Patent No. 6.369,767 discloses an FM antenna characterised by dimensions that can be considered compatible with those to which the present invention relates to. The structure of the antenna disclosed in this patent, however, doesn't have any optimization in order to avoid reduction of the gain by the interaction with the surrounding metal body. Moreover, it requires an additional wire in order to receive the AM signal because the FM antenna is a loop antenna and its grounding on one side is not compatible with the receiving of AM signals.

**[0010]** A passive wirelike structure for increasing the gain of a window antenna for vehicles is known from US-A-2004/008 144. The disclosed passive wirelike structure has the features of the preamble of claim 1.

## SUMMARY OF THE INVENTION

**[0011]** The object of the present invention is to solve the above drawbacks.

**[0012]** More particular, the object of the present invention is to provide a AM-FM antenna having improved performances when located on small window.

**[0013]** A further object of the present invention is to provide an AM-FM antenna which can also be used for other applications with different operative frequencies, like GSM (Global System Mobile) telephone antennas placed on a conductive windscreen within a small non-conductive area.

**[0014]** A further object of the present invention is to provide an AM-FM antenna suitable to be integrated in a free space smaller than those necessary for other solution as being able to reduce for FM waves the negative influence carried out by the surrounding metal body on the antenna gain.

**[0015]** According to the present invention these and other objects, which will result from the following description, are achieved by a passive wirelike structure comprising at least one conductive wirelike segment constituted by metallic tracks, arranged on the window glass provided with the antenna and connected to the metallic chassis delimiting the window; said at least one conductive wirelike segment having a length substantially equal to one quarter of the working wavelength of the antenna and being arranged between said antenna and the metallic border of the metallic chassis delimiting the window glass; wherein said passive wirelike structure is constituted by four wire conductive segments: a first wire conductive segment is connected at one end to the metallic border of the chassis surrounding the window glass; a second conductive wire segment is connected to the first segment and arranged parallel to the next edge of the window glass; and a third segment connecting said second wire segment with a fourth segment, this latter wire segment being arranged parallel to the second wire segment and between the next edge of the window glass

and said second wire segment.

**[0016]** It has been found, in fact, that the passive wirelike structure improves the gain of the antenna by changing the intrinsic resonance of the window.

**[0017]** By the passive wirelike structure of the present invention the influence of the metal body on the antenna gain is reduced.

**[0018]** Moreover, it is possible to use as antenna a monopole structure optimised to be small, for example, by using a fractal shaped profile.

**[0019]** The passive wirelike structure is completely separated from the antenna giving more degree of freedom in the definition and optimisation of the antenna that best cover the required specifications.

**[0020]** Without the passive wirelike structure of the present invention, antennas placed in a window with dimensions (height and/or width or perimeter) in the range of the used wavelength or smaller, have a gain which is strongly affected by the interaction with the conductive chassis. Typically this interaction reduces significantly the performance of the antenna compared with those achievable by the same antenna in a free space environment.

**[0021]** According to the present invention the wirelike passive structure is placed between the antenna and the edge of the conductive chassis delimiting the window glass and connected to this one so that it changes the interaction between the antenna and the surrounding metal body.

**[0022]** The wirelike structure is connected to the conductive chassis either by a direct connection at one end of the wire segment, or by an electromagnetic coupling with the wire segments placed parallel to the edge of the conductive chassis delimiting the window glass.

**[0023]** The wirelike structure is connected to the antenna by the wire segment next to the antenna.

#### BRIEF DESCRIPTION OF THE DRAWINGS

**[0024]** In order to fully understand the present invention, it will be herein below described with reference to the figures of the enclosed drawings which relate to some embodiments illustrating but not limiting the present invention, and wherein:

Figure 1 represents the prospective view of a side window of a vehicle with a segmented line or fractal shaped profile antenna combined with a passive wirelike structure consisting of metal segments, according to the present invention;

Figures 2 and 3 represent the prospective views of different types of antennas applied on side window glasses, having reduced surface, of automotive vehicles, combined with the same type of passive wirelike structure of figure 1, according to the present invention;

Figure 4 illustrates a variation of the passive wirelike structure according to the present invention, used for a different action and a different gain control on an antenna;

Figure 5 shows a passive wirelike structure according to the present invention, arranged on a vehicle windscreen, and

Figure 6 shows a passive wirelike structure according to the present invention, arranged on a rear window of a vehicle.

#### DETAILED DESCRIPTION OF A PREFERRED EMBODIMENT

**[0025]** The wirelike passive structure of the present invention is particularly useful to increase the performances of FM antennas when they are integrated on small windows of vehicles.

**[0026]** Moreover, said passive wirelike structure can be used for applications with different operative frequencies such as GSM (Global System Mobile) telephone antennas placed on a conductive windscreen with a thin metallization for an IR reflecting layer and a small non-conductive area.

**[0027]** More generally, the passive wirelike structure of the present invention can be used when the antenna which is integrated in a non-conductive area surrounded by a conductive one having an intrinsic resonance (which is substantially determined by the perimeter of the non-conductive area) close to the operative frequency of the antenna.

**[0028]** According to the invention, at least one passive wirelike structure made with metallic tracks (for example with a cross section or a width comprised between 0.1 mm and 15 mm) is placed, together with an antenna 8, on a glass 1, particularly a small one, of a vehicle window. This passive wirelike structure improves the performances of the antenna 8 as for gain, modifying the intrinsic resonance of the chassis 2 surrounding the space occupied by the glass 1.

**[0029]** The passive wirelike structure/s made with metal tracks is/are placed on the window glass upon which an antenna 8 is placed between the same antenna and the conductive borders of the chassis 2; the structures are electrically connected to these borders in such a way to change the electromagnetic interaction between the antenna and the surrounding metallic structure.

**[0030]** According to the invention, each passive wirelike structure is coupled with the chassis 2 in two ways: by a direct connection 3, 5 to each side of the wirelike segment 4a, 6a, or by an electromagnetic coupling with segments 4d, 6d which are parallelly placed to the conductive border of the chassis. The structure is also coupled to the antenna 8 with the segments 4b, 6b which are closest to it.

**[0031]** These three kinds of couplings modify the inter-

action between the antenna 8 and the metallic part of the chassis 2 of vehicles and increase the corresponding gain of the same antenna.

**[0032]** The function of the passive wirelike structure is maximized when the segments are oriented in such a way that the connection point to the chassis 3, 5 is on the opposite side of the feeding end 7 of the antenna 8, with respect to the passive segments of the invention.

**[0033]** The resonant frequency of the antenna is close to the intrinsic resonance frequency of the window, that is bound to its perimeter.

**[0034]** In order to modify the effects of the window on the gain of the antenna, the present invention is used by integrating, for example, two wirelike passive structures, a first wirelike passive structure 4a - 4d and a second wirelike passive structure 6a - 6d, on the same window glass (1). The wire segments of said structures are folded in order to be resonant on a frequency very close to that of the antenna. In this way the radio frequency currents of the border of the window are turned off from flowing all around the window 1 and are, instead, driven on the added wirelike passive structure. In such a manner, the intrinsic resonance frequency of the total structure composed by the metallic border around the window plus the wirelike passive structure of the present invention, is different from those of the metallic border alone. The resulted combinations of all the currents, flowing on the antenna and on the surrounding metal parts, bring to a more efficient radiation.

**[0035]** The first segment 4a of the first folded wirelike passive structure at the left side of the antenna is connected at its free end 3 to the conductive chassis 2 around the window 1. The second segment 4b and the fourth segment 4d of the first folded wirelike passive structure are parallel to the border of the window and connected between them by a segment 4c. The fourth segment 4d, which is the end of the wire, is placed between the second segment 4b and the border. The length of the fourth wire segment 4d is shorter than that of the second wire segment 4b and the ratio between the lengths of segments helps to control the influence of the folded wirelike passive structure to the antenna and especially to the gain of the antenna. The total length of the folded wire consisting of all four segments 4a - 4d is round about one quarter of the used wavelength.

**[0036]** In conclusion, the folded wirelike passive structure of the present invention consists of four segments produced by metallic tracks having a cross section or width comprised between 0.1 and 15 mm: a first conductive wire segment 4a connected, in correspondence of an end 3, to the metallic border of the chassis 2 near the window glass 1; a second wire conductive segment 4b connected to the first wire segment 4a and arranged parallel to the next edge of the window 1, the length of this second wire segment 4b being comprised between about one octave and about one quarter of the working wavelength of the antenna 8; a third wire segment 4c connecting said second wire segment 4b with a fourth wire seg-

ment 4d, this latter fourth wire segment arranged parallel to the second segment 4b and between the next edge of the window 1 and said second wire segment 4b; the length of said fourth wire segment 4d being variable to obtain a total length of the four segments 4a - 4d equal to about a quarter of the working wavelength of the antenna 8. The lengths of the first 4a, the third 4c and/or the fourth 4d wire segments may be zero when the length of the second wire segment 4b is one quarter of the working wavelength of the antenna 8.

**[0037]** The second folded wirelike passive structure 6a - 6d at the other side of the antenna 8 is connected at its end 5 to the conductive chassis of the vehicle. The constituting wire segments 6a - 6d are folded as the wire segments 4a - 4d of the first folded wirelike passive structure so that the fourth segment 6d is placed between the second segment 6b and the border of the window 1 at this side of the window.

**[0038]** The length of the first folded wirelike passive structure 4a - 4d can be different from the length of the second folded wire like passive structure 6a - 6d to get a wide band adaptation of the antenna maintaining a high gain level.

**[0039]** The connections at the end 3, 5 between the first segment 4a, 6a of each wirelike folded passive structure and the metallic conductive chassis 2 can be a direct (mechanical) connection. Otherwise an indirect connection is possible by using a capacitive coupling between the first segments 4a and/or 6a and the chassis 2.

**[0040]** Figure 2 and 3 show different types of antenna structures 8 applied on a side glass of a vehicle window combined with the same kind of the folded wirelike passive structure 4a - 4d and 6a - 6d of the present invention. The feeding points of the antennas 8 in both figures are in correspondence of one end 7.

**[0041]** Figure 4 illustrates a variation of the folded wirelike passive structure of the present invention for a different adjustment to the antenna 8 and a different control of the gain. The total length of the wire from the connection point 3 or 5 to the end of the wire is tuned to a length round about a quarter of the used wavelength. The different lengths of the fourth 4d, 6d and of the second 4b, 6b wire segments of the folded wirelike structure are bound to the used antenna 8 and to the distance between the antenna and the folded wirelike passive structure. The ratio between the length of these both segments controls the strength of the coupling between the antenna 8, the folded wirelike passive structures 4a - 4d, 6a - 6d and the conductive chassis 2 around the window glass 1.

**[0042]** Dependent from the available space, it is possible to use a wirelike passive structure where the third and fourth segments 4c, 4d and/or 6c, 6d are completely removed and the passive wirelike structure of the present invention is only constituted by the first and second wire segments 4a, 4b and/or 6a, 6b.

**[0043]** A further possible condition, which depends on the space and/or the shape of the window glass 1, consists in that the second segment 4b and/or 6b and the

fourth segment 4d and/or 6d are not parallel to the border of the window glass 1 and/or are not parallel between them, but the fourth segment 4d and/or 6d is arranged between the border of the window glass 1 and the second segment 4b and/or 6b.

**[0044]** Moreover, the number of the used wirelike passive structures 4a - 4d, 6a - 6d is variable in function of the available space of the window glass 1 and of the antenna type.

**[0045]** Figure 5 shows another application where the wirelike passive structure of the present invention is useful to improve the quality of an antenna. The constellation shown in figure 5 is a windscreen 9 with a reflecting layer able to screen the IR frequencies over nearly the whole area of the window. The IR reflecting layer is constituted by a conductive metallic layer, which extends on all the surface of the windscreen except a limited zone for the application of the antenna 8 without interfering with the function of the antenna. In order to reduce the size of this blank area without affecting the antenna performance, the structure of the present invention can be used to reduce the coupling effects between the antenna and the IR reflecting layer 9. The wire segments 4 and 6 are connected to the reflecting layer 9 either directly or using a capacitive coupling.

**[0046]** The lengths of the wire segments 4 and 6 are also approximately equal to a quarter of the used wavelength of the antenna and are placed with the same criteria of those illustrated in figs. 1 - 4.

**[0047]** The folded wirelike passive structure of the present invention can also be placed on the rear window having an IR reflecting layer 9 to improve the performance of an antenna like shown in figure 6.

**[0048]** Depending from the necessary bandwidth any variation of the number and orientation of the segments forming the wirelike passive structure of the present invention is possible.

**[0049]** It is noted that the total length of the wirelike passive structure 4a - 4d and/or 6a - 6d of the present invention depends from the dielectric characteristics of the window glass 1 on which they are mounted as well as from other optional dielectric materials arranged near said wirelike passive structure.

## Claims

1. An assembly for increasing the gain of a window antenna (8) for a vehicle, said assembly comprising:

- a window glass (1);
- a metallic chassis (2) delimiting the window glass (1);
- an antenna (8) applied to the window glass (1) and having a feeding end (7);
- a passive wirelike structure comprising at least one conductive wirelike segment (4a - 4d, 6a - 6d) constituted by metallic tracks, arranged on

the window glass (1) and connected to the metallic chassis (2) by means of connection point (3, 5), said at least one conductive wirelike segment (4a

- 4d, 6a - 6d) having a length substantially equal to a quarter of the working wavelength of the antenna (8) and being arranged between said antenna (8) and the metallic border of the chassis (2) delimiting the window glass (1);

**characterized in that** said passive wirelike structure is constituted by four wire conductive segments: a first wire conductive segment (4a, 6a) connected at one end by means of said connection point (3, 5) to the metallic border of the chassis (2) surrounding the window glass (1); a second conductive wire segment (4b, 6b) connected to the first segment (4a, 6a) and arranged parallel to an edge of the window glass (1) said edge corresponding to the side where the passive wirelike structure has its first wire conductive segment (4a, 6a) connected to; and a third segment (4c, 6c) connecting said second wire segment (4b, 6b) with a fourth segment (4d, 6d), this latter wire segment being arranged parallel to the second wire segment (4b, 6b) and between said edge of the window glass (1) and said second wire segment (4b, 6b); said passive wirelike structure is completely separated from the antenna (8): and said at least one conductive wirelike segment (4a - 4d, 6a - 6d) is orientated in such way that the connection point (3, 5) to the chassis (2) is on the opposite side of the feeding end (7) of the antenna (8), with respect to the passive segments.

2. The assembly according to claim 1, **characterized in that** the length of the fourth wire segment (4d) is shorter than that of the second wire segment (4b).

3. The assembly according to anyone of the preceding claims, **characterised in that** it further comprises an IR reflecting layer (9) able to screen the IR frequencies and constituted by a conductive metallic layer which extends on all the surface of the window glass (1) except a limited zone for the application of the antenna (8) and the wire segments are connected to said reflecting layer (9) said window glass being a windscreen of a vehicle.

4. The assembly according to anyone of claim 1 or 2, **characterized in that** it further comprises an IR reflecting layer (9) able to screen the IR frequencies and constituted by a conductive metallic layer which extends on all the surface of the window glass (1) except a limited zone for the application of the antenna (8) and the wire segments are connected to said reflecting layer (9), said window glass being a rear vehicle window.

## Patentansprüche

1. Anordnung zur Erhöhung des Gewinns einer Antenne (8) für Fahrzeugfenster, wobei die Anordnung Folgendes umfasst:

- eine Glasscheibe (1) des Fensters;
- eine Metallkarosserie (2), die die Glasscheibe (1) begrenzt;
- eine Antenne (8), die an der Glasscheibe (1) angebracht ist und ein Versorgungsende (7) aufweist;
- eine passive Drahtstruktur, umfassend wenigstens ein aus metallischen Bahnen bestehendes, leitendes Drahtsegment (4a-4d, 6a-6d), das auf der Glasscheibe (1) angeordnet und mit der Metallkarosserie (2) mittels Verbindungsstellen (3, 5) verbunden ist, wobei das wenigstens eine leitende Drahtsegment (4a-4d, 6a-6d) eine Länge aufweist, die im Wesentlichen einem Viertel der Arbeitswellenlänge der Antenne (8) entspricht, und zwischen der Antenne (8) und dem Metallrand der Metallkarosserie (2) angeordnet ist, die die Glasscheibe (1) begrenzt;

### dadurch gekennzeichnet, dass

die passive Drahtstruktur aus vier leitenden Drahtsegmenten besteht: ein erstes leitendes Drahtsegment (4a, 6a), das mittels Verbindungsstelle (3, 5) ein einem Ende mit dem Metallrand der die Glasscheibe (1) umgebenden Karosserie verbunden ist; ein zweites leitendes Drahtsegment (4b, 6b), das mit dem ersten Segment (4a, 6a) verbunden und parallel zu einem Rand der Glasscheibe (1) angeordnet ist, wobei der Rand der Seite entspricht, an der die passive Drahtstruktur mit dem ersten leitenden Drahtsegment (4a, 6a) verbunden ist; und ein drittes Segment (4c, 6c), welches das zweite leitende Drahtsegment (4b, 6b) mit einem vierten Segment (4d, 6d) verbindet, wobei das letzte Drahtsegment parallel zum zweiten Drahtsegment (4b, 6b) und zwischen dem Rand der Glasscheibe (1) und dem zweiten Drahtsegment (4b, 6b) angeordnet ist; die passive Drahtstruktur vollkommen von der Antenne (8) getrennt ist; und das wenigstens eine leitende Drahtsegment (4a - 4d, 6a - 6d) derart ausgerichtet ist, dass die Verbindungsstelle (3, 5) mit der Karosserie (2) sich auf der gegenüberliegenden Seite des Versorgungsendes (7) der Antenne (8) in Bezug auf die passiven Segmente befindet.

2. Anordnung nach Anspruch 1, **dadurch gekennzeichnet, dass** die Länge des vierten Drahtsegments (4d) kürzer als die des zweiten Drahtsegments (4b) ist.

3. Anordnung nach einem der vorstehenden Ansprüche, **dadurch gekennzeichnet, dass** sie ferner eine IR-reflektierende Schicht (9) umfasst, die in der Lage ist, die IR-Frequenzen abzuschirmen und aus einer leitenden Metallschicht besteht, die sich über die gesamte Oberfläche der Glasscheibe (1) erstreckt, mit Ausnahme eines begrenzten Bereichs zur Anbringung der Antenne (8), und die Drahtsegmente mit der reflektierenden Schicht (9) verbunden sind und die Glasscheibe die Windschutzscheibe eines Fahrzeugs ist.

4. Anordnung nach einem der Ansprüche 1 oder 2, **dadurch gekennzeichnet, dass** sie ferner eine IR-reflektierende Schicht (9) umfasst, die in der Lage ist, die IR-Frequenzen abzuschirmen und aus einer leitenden Metallschicht besteht, die sich über die gesamte Oberfläche der Glasscheibe (1) erstreckt, mit Ausnahme eines begrenzten Bereichs zur Anbringung der Antenne, und die Drahtsegmente mit der reflektierenden Schicht verbunden sind und die Glasscheibe die Heckscheibe eines Fahrzeugs ist.

## Revendications

1. Groupe pour augmenter le gain d'une antenne (8) pour fenêtre de véhicule, ledit groupe comprenant :

- une vitre (1) d'une fenêtre ;
- un cadre métallique (2) qui délimite la vitre (1) ;
- une antenne (8) appliquée à la vitre (1) et dotée d'une extrémité d'alimentation (7) ;
- une structure filiforme passive comprenant au moins un segment filiforme conducteur (4a-4d, 6a-6d) composé de pistes métalliques, disposées sur la vitre (1) et branché au cadre métallique (2) moyennant des points de connexion (3, 5), ledit au moins un segment filiforme conducteur (4a-4d, 6a-6d) ayant une longueur essentiellement égale à un quart de la longueur d'onde opérationnelle de l'antenne (8) et étant disposé entre l'antenne (8) et le bord métallique du cadre métallique (2) qui délimite la vitre (1) ;

### caractérisé en ce que

ladite structure passive filiforme est composée par quatre segments filiformes conducteurs : un premier segment filiforme conducteur (4a, 6a) raccordé à une extrémité au bord métallique du cadre qui entoure la vitre (1), moyennant ledit point de connexion (3, 5) ; un deuxième segment filiforme conducteur (4b, 6b) raccordé au premier segment (4a, 6a) et disposé parallèle à un bord de la vitre (1), ledit bord correspondant au côté sur lequel la structure filiforme passive a son premier segment filiforme conducteur (4a, 6a) raccordé ; et un troisième segment (4c, 6c) qui raccorde ledit deuxième segment filiforme conduc-

teur (4b, 6b) à un quatrième segment (4d, 6d), ce dernier segment filiforme étant disposé parallèle au deuxième segment filiforme (4b, 6b) et entre ledit bord de la vitre (1) et ledit deuxième segment filiforme (4b, 6b) ;  
 ladite structure filiforme passive est complètement séparée de l'antenne (8) ; et  
 ledit au moins un segment filiforme conducteur (4a - 4d, 6a - 6d) est orienté de manière à ce que le point de connexion (3, 5) au cadre (2) se trouve du côté opposé de l'extrémité d'alimentation (7) de l'antenne (8) par rapport aux segments passifs.

5

10

2. Groupe selon la revendication 1, **caractérisé en ce que** la longueur du quatrième segment filiforme (4d) est plus courte que celle du deuxième segment filiforme (4b). 15
3. Groupe selon l'une quelconque des revendications précédentes, **caractérisé en ce qu'il** comprend également une couche réfléchissante IR (9) apte à blinder les fréquences IR et composé d'une couche métallique conductrice qui se déploie sur toute la surface de la vitre (1), à l'exception d'une zone limitée pour l'application de l'antenne (8) et les segments filiformes sont raccordés à ladite couche réfléchissante (9) et ladite vitre étant un pare-brise d'un véhicule. 20 25
4. Groupe selon l'une quelconque des revendications 1 ou 2, **caractérisé en ce qu'il** comprend également une couche réfléchissante IR (9) apte à blinder les fréquences IR et composé d'une couche métallique conductrice qui se déploie sur toute la surface de la vitre (1), à l'exception d'une zone limitée pour l'application de l'antenne (8) et les segments filiformes sont raccordés à ladite couche réfléchissante (9) et ladite vitre étant une lunette arrière du véhicule. 30 35

40

45

50

55



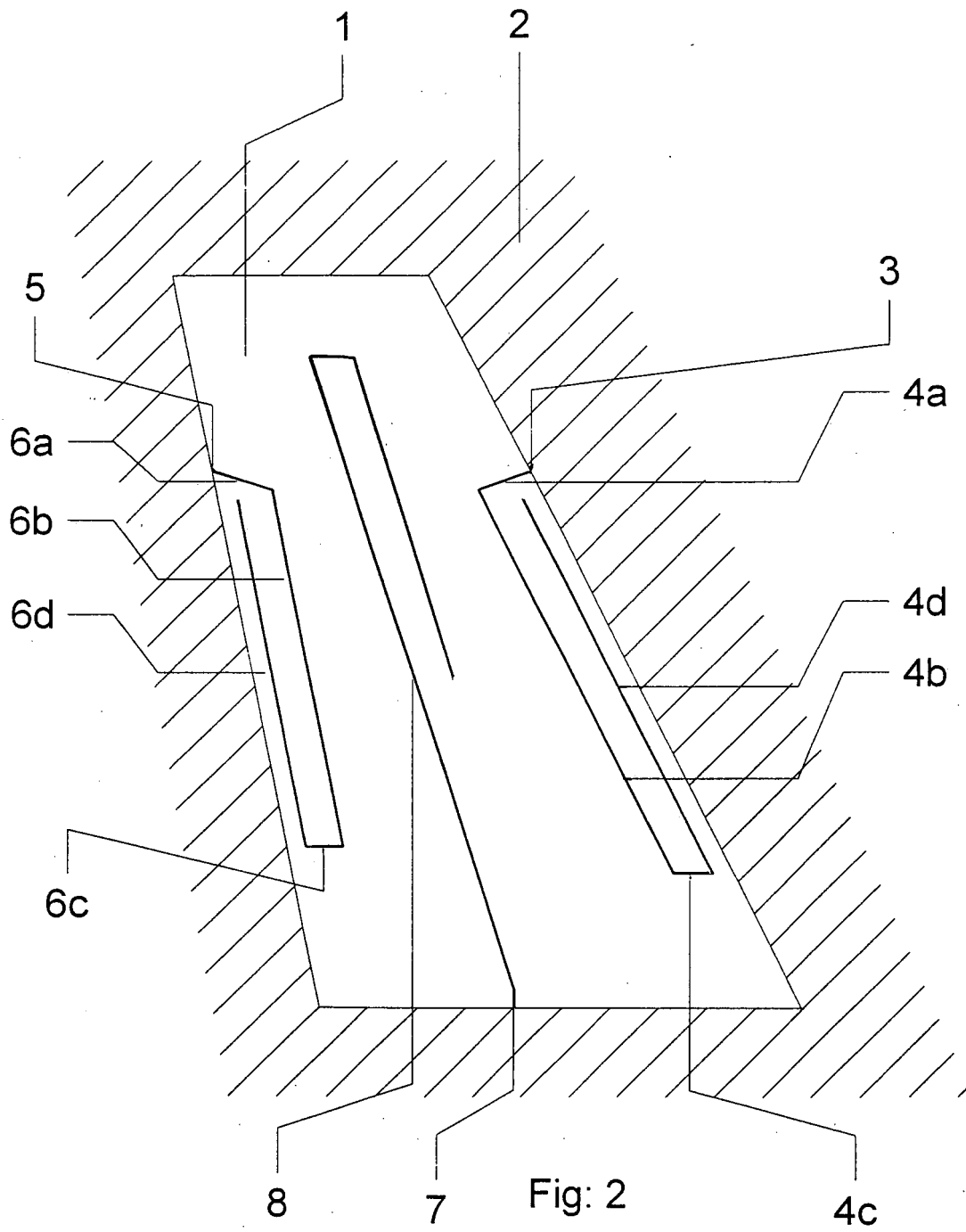

Fig: 2

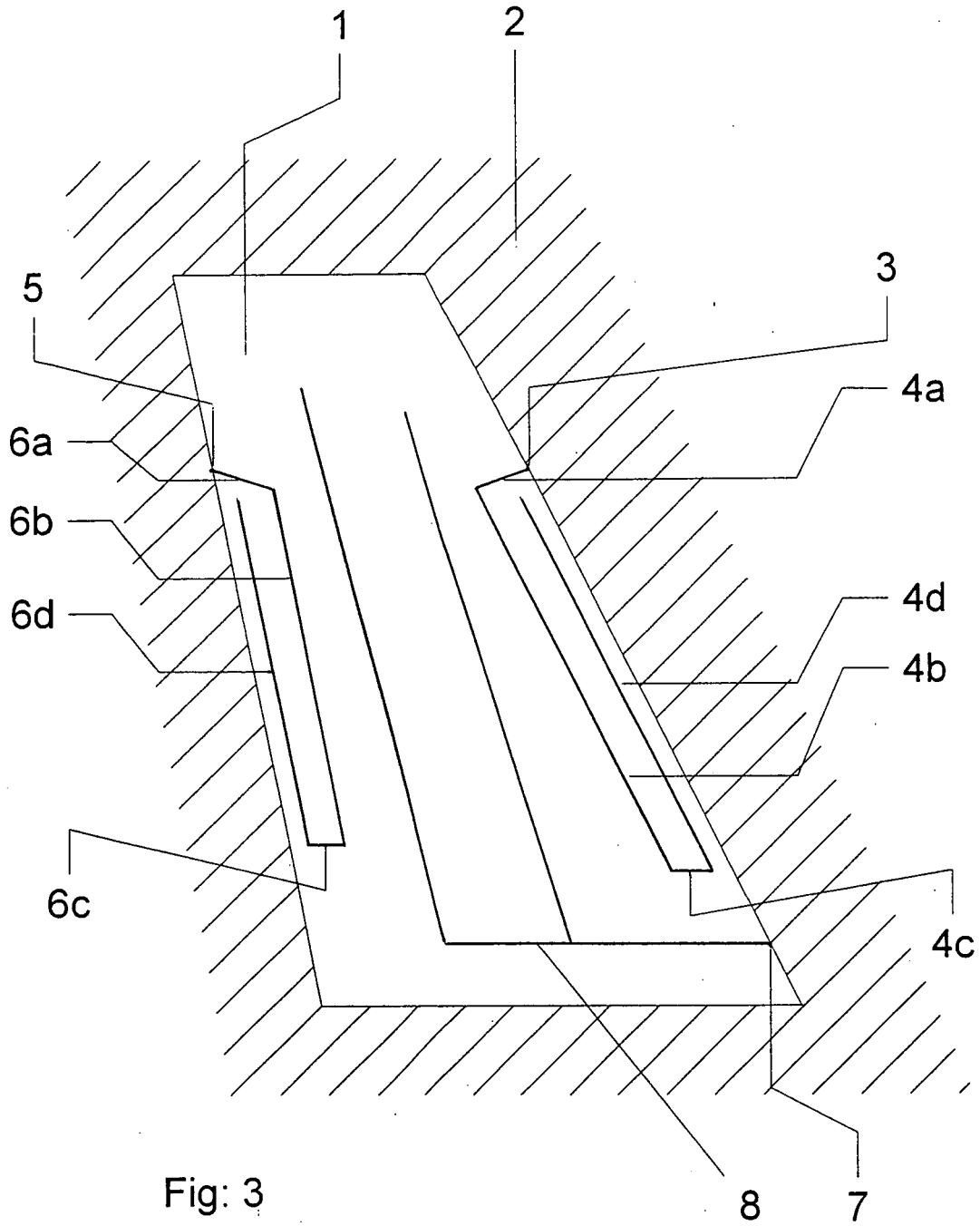
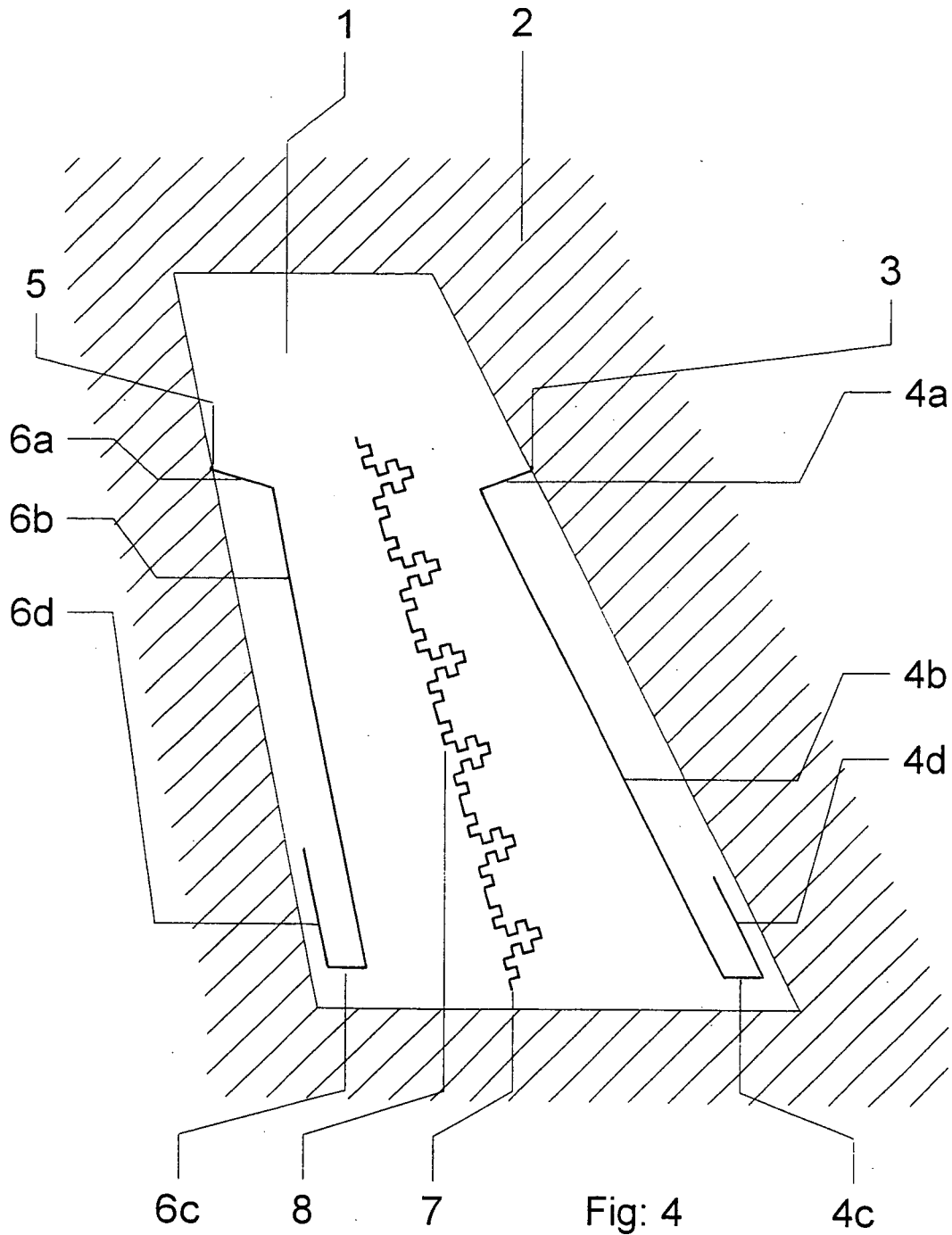

Fig: 3



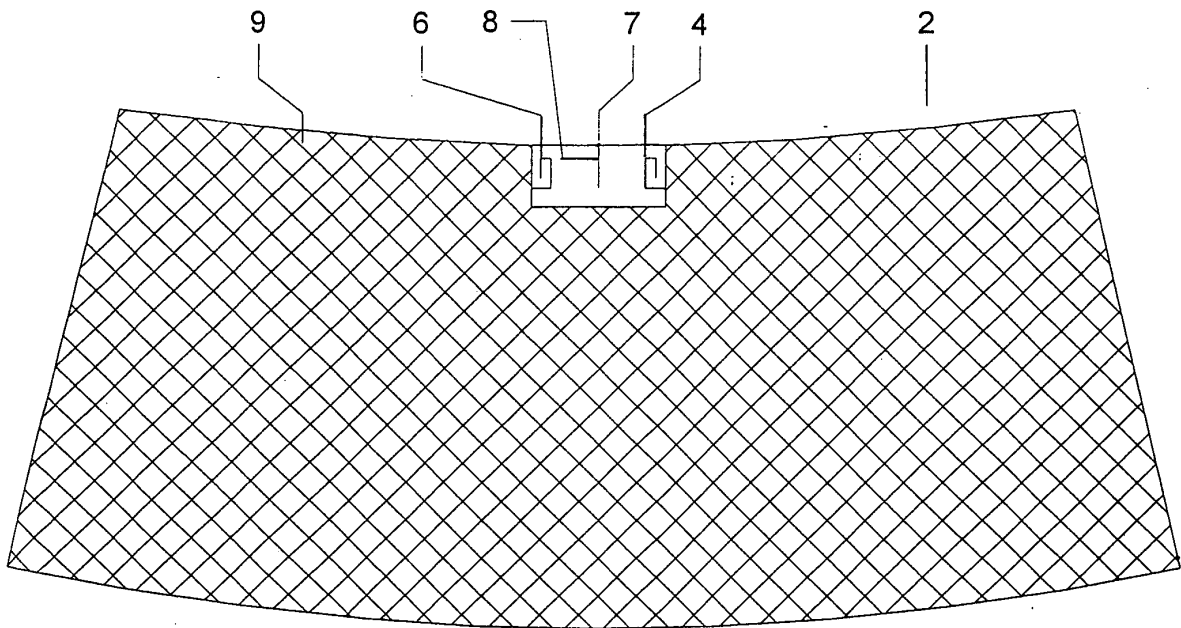

Fig: 5

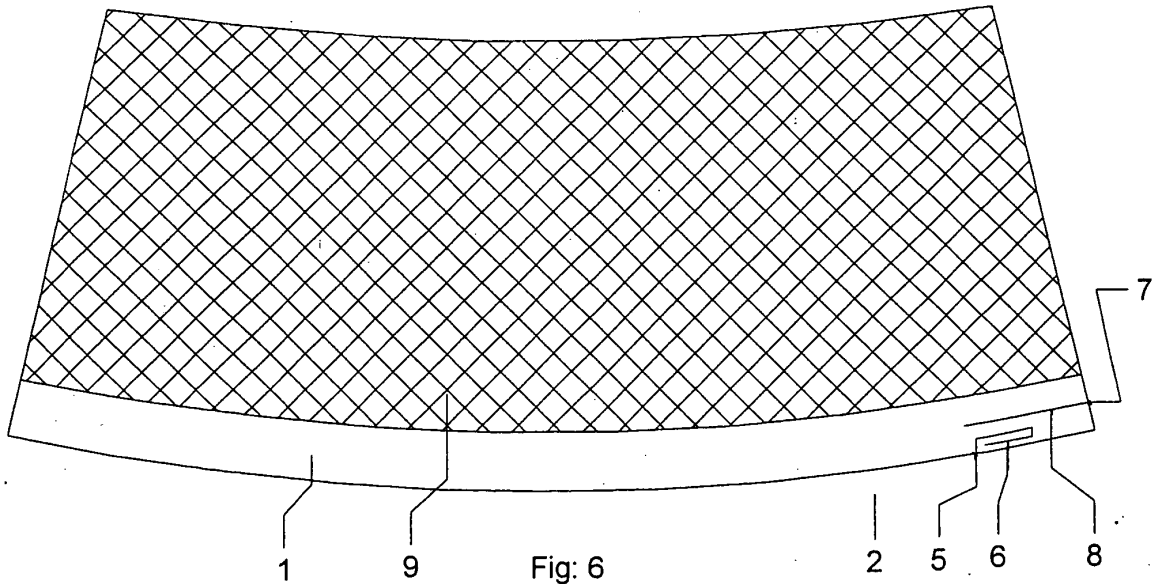

Fig: 6

**REFERENCES CITED IN THE DESCRIPTION**

*This list of references cited by the applicant is for the reader's convenience only. It does not form part of the European patent document. Even though great care has been taken in compiling the references, errors or omissions cannot be excluded and the EPO disclaims all liability in this regard.*

**Patent documents cited in the description**

- US 5510804 A [0004]
- US 5905470 A [0005] [0006] [0007]
- US 6437749 B [0005] [0007]
- US 6369767 B [0009]
- US 2004008144 A [0010]