

(No Model.)

2 Sheets—Sheet 1.

W. HALL.

APPARATUS FOR HOLDING WINDOW SASHES.

No. 557,268.

Patented Mar. 31, 1896.

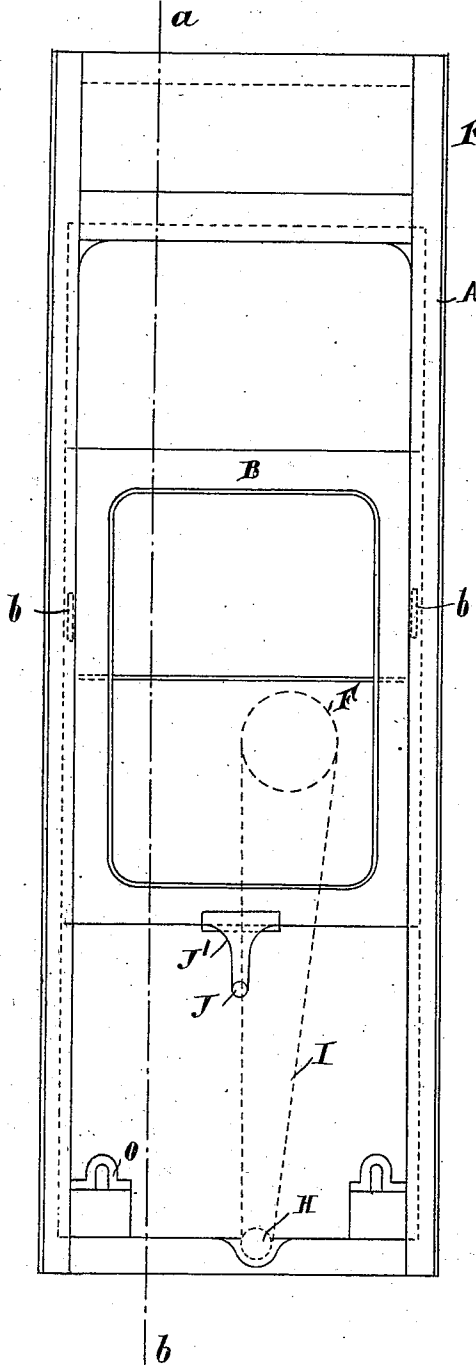

Fig. 1.

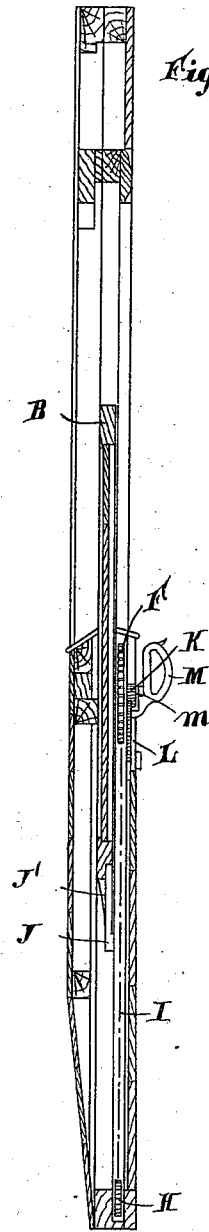

Fig. 2.

Witnesses
M. V. Bulford
J. G. Green

Investor
Walter Hall
 By *Henry L. ...*
Attys

W. HALL.

APPARATUS FOR HOLDING WINDOW SASHES.

No. 557,268.

Patented Mar. 31, 1896.

Fig. 3.

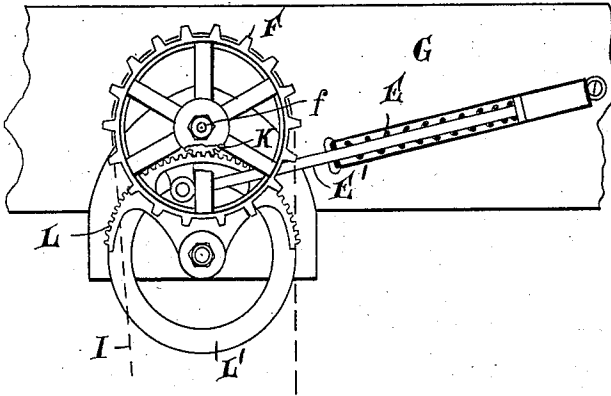

Fig. 4.

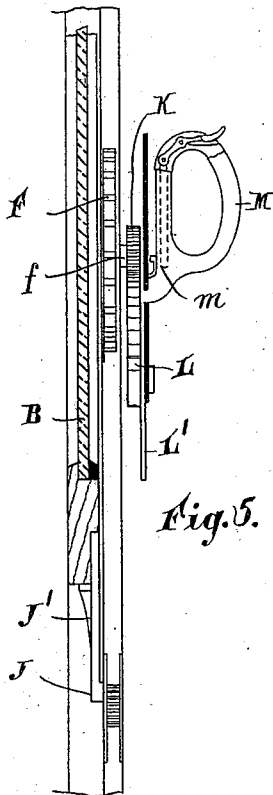
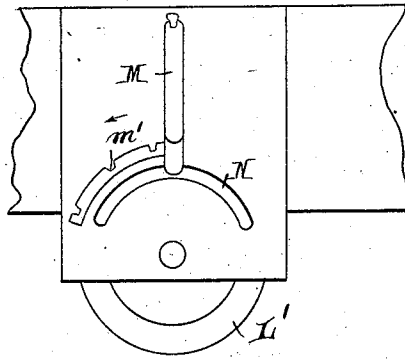

Fig. 5.

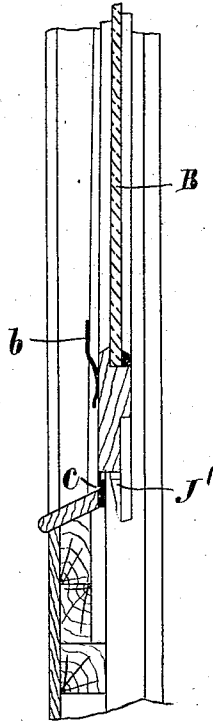

Fig. 6.

Witnesses
D. V. Bilegood
J. Green

Inventor
William Hall
 By *Amos A. ...*
Attor

UNITED STATES PATENT OFFICE.

WATKIN HALL, OF GREAT CROSBY, ENGLAND.

APPARATUS FOR HOLDING WINDOW-SASHES.

SPECIFICATION forming part of Letters Patent No. 557,268, dated March 31, 1896.

Application filed January 24, 1895. Serial No. 536,020. (No model.) Patented in England January 31, 1894, No. 2,131.

To all whom it may concern:

Be it known that I, WATKIN HALL, civil engineer, a subject of the Queen of Great Britain, residing at Great Crosby, in the county of Lancaster, England, have invented certain new and useful Improvements in Apparatus for Holding Window-Sashes, (for which I have received Letters Patent in England, No. 2,131, dated January 31, 1894,) of which the following is a specification.

This invention has for its object a method of and apparatus for raising and lowering railway-carriage and other window-sashes.

In the accompanying drawings, Figure 1 shows a standard English railway-carriage door fitted with my improved apparatus, parts being removed for clearness. Fig. 2 is a section on the line *a b*, and Figs. 3, 4, 5, and 6 enlarged details.

In the figures, A is the carriage-door; B, the window-sash; F, a chain or sprocket wheel mounted on a stud or pin *f* fixed to the cross-rail G of the door, and H a second sprocket wheel or pulley mounted in a bracket fixed to the bottom rail of the door. A chain I or band of wire, sash-cord, or the like, which connects these wheels F and H, is also fixed to a joint-pin J in a bracket J', on which the window-sash rests.

K is a pinion on the axis of the chain-wheel F, gearing with a spur-wheel or toothed segment L. This latter is rotated by means of a handle M, which passes through a curved slot N in a plate let into the cross-rail G of the door. This handle projects into the carriage, &c., whereby the people in the carriage, &c., by rotating the handle through the required arc can raise or lower the window.

To counteract the weight of the window, the toothed segment L is provided with a spring E, which can be placed at any convenient point and operated by the rod E'. The ordinary buffer O can be placed below, so that when the window-sash is let fall it shall not strike the bottom with force. The toothed segment L carries a guard L' to close the slot N wherever the handle M may be. The before-mentioned gearing is preferably arranged in a cut-away portion of the cross-rail G, as shown in Figs. 2 and 3, and is also so designed that when the handle M has traveled the full length of the curved slot N

the sash B will have been raised to its full height and is clear of the fence-plate.

To facilitate the opening of the window, a spring *b*, Fig. 6, may be placed in the sash-groove, which spring, when the sash is up and about to engage the fence-plate *c*, is compressed, and will therefore press the sash inward when raised by the handle M clear of the said fence-plate.

The rod E', engaging the spring E, is pivoted to a radial point of the circular rack L, while the end of the casing confining the spring is pivoted to a fixed point. The result of this construction is that the tendency of the spring will be to move the radius of the circular rack, to which rod E' is pivoted, toward the position where the spring would be tangential to it, and the rack will have a motion in the contrary direction in raising the window. The resistance of the spring will therefore increase as the versed sine of the angle of the radius of attachment with the perpendicular to the tangent diminishes, or the leverage upon the counterbalancing-spring will be reduced as the force of the spring increases, so that the pressure of the spring in counterbalancing the window will be approximately uniform.

The mode of operation is as follows: To raise the sash, the handle M is turned in the direction of the arrow, Fig. 4, and by means of the gearing L, K, and F causes the chain I to travel, and thereby raises the window-sash, which raising is also assisted by the spring E. The sash is raised a distance proportionable to the arc through which the handle M is rotated. The drawing shows the sash raised about half-way. The handle M has a spring locking-catch *m*, Fig. 5, which engages with notches *m'*, Fig. 4, to allow the said handle being locked in any desired position. Any other locking device may be employed, such as a spring-pin on the handle engaging holes, or the handle might be arranged to engage itself with a small spring when the sash is raised to its highest point. The window-sash may be lowered by reversing the movement of the handle, first of course raising the sash so as to clear the fence-plate. Buffer-springs O have for their object to buffer the sash when the window is suddenly lowered.

I do not confine myself to the exact form of

mechanism herein described and illustrated, as this may be altered without departing from the spirit of the invention. For instance, pulleys may be employed instead of the sprocket-wheels F and H, and the gearing may take other forms well known to mechanics, whereby the same results may be obtained. Moreover, the invention may be applied equally well to almost all kinds of road and railway cars, including railway-cars on the American system, in which the sashes are raised to open the windows and lowered to close the same, the handles M in that case being located at the top of the windows or at the side between the windows.

The invention may even be applied with advantage to raising and lowering domestic windows or windows in public buildings.

I declare that what I claim is—

1. In a window-sash, the arrangement for counteracting the weight of the window, which consists in providing in combination with a pulley F, a toothed segment K geared thereto and a spring device E coupled to the segment L, substantially as described.

2. The combination, with a frame such as a window requiring to be raised and lowered, of a sprocket-and-chain device for raising and lowering the same placed entirely below the window when closed and provided with an operating-handle 7, a multiplying-gear between the operating-handle and the sprocket-wheel, and a counterbalanced spring acting on the multiplying-gear, whereby, with a comparatively slight movement of the operating-handle and spring, a large movement of the window takes place and all the mechanism can be hid in the window-box below the position of the window when closed, as set forth.

3. In combination, with a frame such as a

window requiring to be raised and lowered, of a bracket J fixed to the sash below the same, two sprocket-wheels near the vertical extremities of the window-box, a sprocket-chain connected to said bracket and passing around said sprocket-wheels, and mechanism for winding up and down the sprocket-chain, and for counterbalancing the said window, substantially as described, whereby a sprocket-chain placed entirely below the position which the window is to occupy when closed can be used to close the window.

4. The combination, in a window-raising device, of a circular rack L, a counterbalancing-spring E pivoted to a radius of the same and to a fixed point, said spring having a tendency to bring the radius to which it is attached toward the position where the spring would be tangential to it, and the rack in raising the window having a motion in the contrary direction, whereby the resistance of the spring increases as the versed sine of the angle of the radius of attachment with the perpendicular to the tangent diminishes, and thus the counterbalancing of the window is approximately uniform, as set forth.

5. In combination with a window-raising device, a counterbalancing-spring arranged in such manner that as the force of the spring increases the leverage thereon is reduced, and thus the pressure of the spring in counterbalancing the sash is practically uniform, as set forth.

In testimony whereof I have signed my name to this specification in the presence of two subscribing witnesses.

WATKIN HALL.

Witnesses:

GEO. BARTON,
EDWARD CAHILL.