

(19) World Intellectual Property  
Organization  
International Bureau



(43) International Publication Date  
19 February 2004 (19.02.2004)

PCT

(10) International Publication Number  
**WO 2004/015237 A2**

- (51) International Patent Classification<sup>7</sup>: **E21B 17/00**
- (21) International Application Number:  
PCT/US2003/024298
- (22) International Filing Date: 5 August 2003 (05.08.2003)
- (25) Filing Language: English
- (26) Publication Language: English
- (30) Priority Data:  
10/213,963 7 August 2002 (07.08.2002) US  
10/213,966 7 August 2002 (07.08.2002) US  
10/626,044 24 July 2003 (24.07.2003) US
- (71) Applicant: **DEEPWATER TECHNOLOGIES, INC.**  
[US/US]; 11700 Old Katy Road Suite 150, Houston, TX  
77079 (US).
- (72) Inventor: **HORTON, Edward, E., III**; 6114 Crab Orchard,  
Houston, TX 77057 (US).
- (74) Agent: **KLEIN, Howard, J.**; Klein, O'Neill & Singh,  
LLP, 2 Park Plaza, Suite 510, Irvine, CA 92614 (US).
- (81) Designated States (*national*): AE, AG, AL, AM, AT, AU, AZ, BA, BB, BG, BR, BY, BZ, CA, CH, CN, CO, CR, CU, CZ, DE, DK, DM, DZ, EC, EE, ES, FI, GB, GD, GE, GH, GM, HR, HU, ID, IL, IN, IS, JP, KE, KG, KP, KR, KZ, LC, LK, LR, LS, LT, LU, LV, MA, MD, MG, MK, MN, MW, MX, MZ, NO, NZ, OM, PH, PL, PT, RO, RU, SC, SD, SE, SG, SK, SL, TJ, TM, TN, TR, TT, TZ, UA, UG, UZ, VC, VN, YU, ZA, ZM, ZW.
- (84) Designated States (*regional*): ARIPO patent (GH, GM, KE, LS, MW, MZ, SD, SL, SZ, TZ, UG, ZM, ZW), Eurasian patent (AM, AZ, BY, KG, KZ, MD, RU, TJ, TM), European patent (AT, BE, BG, CH, CY, CZ, DE, DK, EE, ES, FI, FR, GB, GR, HU, IE, IT, LU, MC, NL, PT, RO, SE, SI, SK, TR), OAPI patent (BF, BJ, CF, CG, CI, CM, GA, GN, GQ, GW, ML, MR, NE, SN, TD, TG).
- Published:**  
— *without international search report and to be republished upon receipt of that report*
- For two-letter codes and other abbreviations, refer to the "Guidance Notes on Codes and Abbreviations" appearing at the beginning of each regular issue of the PCT Gazette.*



WO 2004/015237 A2

(54) Title: OFFSHORE WELL PRODUCTION RISER

(57) Abstract: An offshore oil well riser system that compensates for the motions of an associated floating platform comprises a vertical pipe section supported by the floating vessel and extending downward from the vessel substantially perpendicular to the sea floor, and a horizontal pipe section connected to the associated sub-sea well equipment and extending away from the equipment substantially parallel to the sea floor. A angled elbow pipe connects the horizontal pipe to the vertical pipe. At least one of the horizontal and the vertical pipes incorporates a flexing portion comprising a plurality of recurve sections of pipe connected end-to-end with alternating curvatures. In one embodiment, the central axis of the flexing portion lies in a single plane and takes a sinusoid path. In another embodiment, the central axis of the flexing portion takes a three dimensional helical path.

## OFFSHORE WELL PRODUCTION RISER

## CROSS-REFERENCE TO RELATED APPLICATIONS

This Application is a continuation-in-part of co-pending U.S. Pat. App. Ser. Nos. 10/213,966 and 10/213,963, both filed August 7, 2002.

5

STATEMENT REGARDING FEDERALLY  
SPONSORED RESEARCH OR DEVELOPMENT

(Not Applicable)

## REFERENCE TO APPENDIX

(Not Applicable)

10

## BACKGROUND OF THE INVENTION

1. *Field of the Invention*

This invention relates, in general, to offshore oil well risers that convey petroleum from producing wells on the sea floor to a floating platform on the sea surface, and in particular, to risers that are capable of accommodating large motions of the platform relative to the wells without damage.

15

2. *Description of Related Art*

Conventional "dry tree" floating offshore platforms for drilling and production of oil and gas typically include such "low heave" designs as Spar platforms, Tension Leg Platforms ("TLPs"), and Deep-Draft semi-submersible platforms. These platforms are capable of supporting a plurality of vertical production and/or drilling "risers," *i.e.*, long pipes extending up from oil and gas wells on the sea floor to the platforms. The platforms typically comprise a "well deck," where surface "trees," *i.e.*, control valves disposed on the top ends of the risers, are located, and a production deck, where the crude oil is collected from the risers and fed to a processing facility for separation of water, oil and gas. In conventional dry tree offshore platforms, the risers extend from the respective well heads to the well deck and are supported thereon by a tensioning apparatus, and such risers are thus termed Top-Tensioned Risers ("TTRs").

25

One known TTR design uses "active" hydraulic tensioners located on the well deck to support each riser independently of the others. Each riser extends vertically from the well head to a tensioner located on the well deck of the platform, and is supported there by hydraulic cylin-

ders connected to the well deck. The cylinders enable the platform to move up and down relative to the risers, and thereby partially isolate the risers from the heave motions of the hull. A surface tree is attached at the top of each riser, and a flexible, high-pressure jumper hose connects the surface tree to the production deck. However, as the tension force and displacement requirements of the hydraulic cylinders increase, these active tensioners become prohibitively expensive. Further, the offshore platform must be capable of supporting the combined load of all the risers.

A second TTR design uses passive "buoyancy cans" to support the risers independently of the platform, as illustrated in the schematic elevation view of Fig. 1 of the accompanying drawings. In this design, each riser 100 extends vertically from the well head through the keel of the floating platform and into a "stem pipe," to which the buoyancy cans are attached. This stem pipe extends above the buoyancy cans and supports a platform to which the risers and the surface trees are attached. A flexible, high pressure jumper hose connects the surface trees to the production deck of the platform. Since the risers are independently supported by the buoyancy cans relative to the hull of the platform, the hull is able to move up and down relative to the risers, and thus, the risers are isolated from the heave motions of the platform. The buoyancy cans must provide sufficient buoyancy to supply the required top tension in the risers, as well as support the weight of the can, stem, and the surface tree. At greater depths, the buoyancy required to support the riser system is proportionately greater, resulting in relatively large buoyancy cans. Consequently, the deck space required to accommodate all the risers increases substantially. Designing and manufacturing individual buoyancy cans for each riser in deep water applications is therefore costly.

Conventional "wet tree" offshore platforms include Floating Production Storage and Off-loading ("FPSO") and semi submersible platforms. These types of platforms have relatively large motions that make it impractical for them to support vertical production and drilling risers, and accordingly, are generally used in connection with a sub-sea completion system, *i.e.*, sub-sea trees, which are arranged on the seafloor. Produced crude oil is typically conveyed along the seafloor with flow-lines and gathered in a manifold. Production risers then carry the crude oil from the manifold or sub-sea tree to the process equipment of the floating support. As the floating support has relatively large motions (both heave and horizontal), the production risers must be designed to accommodate these large motions.

Production risers can also comprise flexible, reinforced elastomeric risers. Flexible risers are connected directly to the floating platform, and thus take the shape of a catenary that extends from the floating support to the sea floor, as illustrated schematically in Fig. 2, in which a flexible riser 200 is shown. Because of their shape and construction, and particularly their flexibility, flexible risers are better able to accommodate the motions of the platform. However, they are also relatively heavy and expensive. Alternatively, the risers can comprise so-called Steel Catenary Risers ("SCRs"). These connect directly to the floating support through a flexible joint or similar mechanism and also present a catenary shape when deployed. Because they are made of steel, SCRs are less expensive than flexible risers, but because they are also stiffer, are prone to fatigue problems caused by dynamic motions and require greater lengths to absorb the vessel motion.

Another known dry tree riser system is the so-called "riser tower." In this system, the riser tower comprises one or more rigid vertical pipes connected to the seafloor through a pivot connection or stress joint. The pipes are supported by a large top buoyancy device which provides sufficient buoyancy to support the pipes and prevent them from going slack or vibrating in response to ocean currents. Flexible jumpers are used to connect the vertical pipes to the floating support. This type of riser system is both expensive and difficult to install.

In light of the foregoing, a long felt but as yet unsatisfied need exists in the petroleum industry for a low-cost, simple, yet reliable offshore oil well riser system that compensates for the motions of an associated floating platform.

#### BRIEF SUMMARY OF THE INVENTION

In accordance with the present invention, an offshore oil well riser system is provided that compensates for the motions of an associated floating drilling or production platform. The riser system is relatively inexpensive, simple to fabricate and deploy, and reliable in operation.

The novel riser comprises a rigid vertical pipe section that is supported by the floating vessel, and which extends downward from the vessel substantially perpendicular to the sea floor, and a rigid horizontal pipe section that is connected to the associated sub-sea well equipment (*i.e.*, the well head, sub-sea tree, split tree, manifold, or the like), and which extends away from the equipment substantially parallel to the sea floor. A relatively short, inflexible angled pipe section, *i.e.*, an "elbow," connects the horizontal pipe to the vertical pipe. In a preferred embodiment, the vertical pipe section predominates over the others such that the overall riser sys-

tem presents a substantially vertical shape, and only a relatively small, substantially horizontal pipe section is used to connect the riser to the sub-sea well head equipment.

Since the riser is directly supported by the floating platform, motions of the platform (*i.e.*, heave, surge, sway, pitch, roll, and yaw) are transmitted to the riser, and must therefore be absorbed by the horizontal and vertical pipes. To limit the resulting stress and fatigue in these two sections, at least one of them is provided with a flexing portion that is able to absorb the motion of the platform imparted to the riser. This flexing portion can be arranged in the vertical pipe section, in the horizontal pipe section, or in both. The flexing portion comprises a plurality of recurvate sections of pipe connected end-to-end with alternating curvatures. In one possible embodiment thereof, the central axis of the flexing portion lies in a single plane and takes a sinuous path, *e.g.*, that of a sinusoid. In another possible embodiment, the central axis of the flexing portion takes a three dimensional path, *e.g.*, that of a helix. Many other configurations of the flexing portion are possible.

Both the angled pipe section, *i.e.*, the elbow, and the flexing portion of the novel riser can be designed to easily accommodate wire line, coiled tubing or "pigging" operations internally. The floating vessel supports the riser, and thus, no expensive buoyancy cans are required. Since all vessel motions are absorbed by the riser, neither a flexible jumper nor a long length of pipe is required to accommodate the motion. Additionally, since the major portion of the riser is substantially vertical, the total length of riser required is substantially reduced, relative to a catenary shape, and since it is made entirely of steel pipe, it is cost-effective to make.

A better understanding of the above and many other features and advantages of the present invention may be obtained from a consideration of the detailed description thereof below, especially if such consideration is made in conjunction with the views of the appended drawings.

#### BRIEF DESCRIPTION OF THE SEVERAL VIEWS OF THE DRAWINGS

- Figure 1 is a schematic elevation view of a prior art offshore oil well riser system;  
Fig. 2 is a schematic elevation view of another prior art riser system;  
Fig. 3 is schematic elevation view of an exemplary embodiment of an offshore oil well riser system in accordance with the present invention;  
Fig. 4 is an enlarged elevation view of the exemplary riser system shown in Fig. 3;  
Fig. 5 is an elevation view of exemplary embodiment of an another riser system in accordance with the present invention;

Figs. 6 and 7 are perspective views of the centerline of the riser of the system illustrated in Fig. 4, showing displacements of the riser in response to surface platform movements;

Fig. 8 is a partial elevation view of a riser in accordance with another exemplary embodiment of the present invention;

5 Fig. 9 is a partial elevation view of a riser in accordance with another exemplary embodiment of the present invention;

Fig. 10 is an elevation view of an exemplary embodiment of another riser system in accordance with the present invention;

10 Figs. 11-13 are schematic elevation views of exemplary embodiments of other riser systems in accordance with the present invention.

### DETAILED DESCRIPTION OF THE INVENTION

An offshore oil well riser system 10 in accordance with one exemplary embodiment of the present invention is illustrated in the respective schematic and enlarged elevation views of Figs. 3 and 4. The riser system comprises a substantially horizontal well entry pipe section 12  
15 connected to a wellhead 14 located on the sea floor 16. An angulated elbow section of pipe 18 connects the horizontal well entry pipe 12 to a substantially vertical riser pipe section 20, which in turn, is connected to and supported by a vessel 22 that floats on the surface of the water, *e.g.*, a Spar platform, an FPSO, or any type of floating platform. In one advantageous embodiment, the horizontal well entry pipe, the elbow and the vertical riser pipe are all made of steel. Although  
20 steel risers are relatively much stiffer than flexible risers, they nevertheless have sufficient resilience and elasticity to bend and flex in response to the motions of the floating vessel, such that the forces thereby exerted on the riser are substantially isolated from the wellhead.

As a practical matter, because of the relatively large depths in which the riser system 10 is deployed, the length of the vertical pipe section 20 is much greater than that of the horizontal  
25 pipe section 12, and accordingly, the overall riser 10 presents a substantially vertical aspect. Also, as will be appreciated by those of skill in the art, "substantially horizontal" and "substantially vertical" are relative terms, as both the horizontal and vertical sections of pipe move through relatively large angles relative to the sea floor 16 in response to movement of the surface vessel 22, as illustrated schematically in Figs. 6 and 7, in which movement of the central axis 24 of the  
30 riser with respect to the sea floor in response to surface vessel movement is shown before (solid line) and after (dashed line) displacement.

An alternative exemplary embodiment of a riser system 10 in accordance with the present invention is illustrated in Fig. 5. In this embodiment, a riser "spur" pipe 24, comprising a short, substantially vertical pipe section, is connected at one end to the wellhead 14. As in the first embodiment above, an elbow section 18 connects the other end of the spur pipe to a substantially vertical riser pipe section 20, which in turn, is connected to and supported by the floating vessel 22. In the first embodiment of Fig. 1, the elbow section 18 is bent at an angle of about 90° to accommodate the horizontal and vertical sections of pipe. In the second embodiment of Fig. 5, the elbow is bent at an angle of about a 45° to accommodate the substantially vertical stub pipe, and accordingly, the lower end portion 24 of the vertical pipe section 20 is curved tangentially at about 45° to attach to the elbow. Of course, a plurality of elbows having a variety of other included angles may be used to connect the sections of the riser together, and in some possible embodiments, the walls of the elbows can incorporate bellows-like convolutions to render them more flexible.

The flexing of the riser system 10 illustrated in Figs. 6 and 7 comprises flexing of the horizontal and vertical pipe sections 12 and 20 in a direction generally perpendicular to their respective long axes. By such flexing, the riser can absorb a considerable amount of the energy associated with movement of the floating-vessel 22 without buckling. However, as described in more detail below, it is possible to further increase the amount of surface vessel motion that the riser system can accommodate by incorporating one or more "flexing portions" into the pipe sections of the riser that enable the sections to flex in directions both perpendicular and parallel to their respective long axes.

As illustrated in Figs. 8 and 9, the flexing portion 30 of the riser 10 comprises a plurality of recurvate pipe sections 32 that are connected end-to-end, *e.g.*, with flanges or by welding, with their respective curvatures in an alternating arrangement. In one advantageous embodiment, the central axis of the flexing portion lies in a single plane and takes a sinuous path, *e.g.*, that of a sinusoid, as illustrated in Fig. 8. In another advantageous embodiment, the curved sections also include an axial twist, such that the central axis of the flexing portion takes a three dimensional path, *e.g.*, that of a helix. Of course, the flexing portions may advantageously have many other possible two- and three-dimensional geometries. The dimension  $P$  between equivalent points in adjacent recurvate sections of the flexing portion is referred to herein as the wavelength of the portion, for a two-dimensional configuration, or its pitch, for a three-dimensional configuration,

and the dimension  $R$  relates to the amplitude of the portion, for a two-dimensional configuration, or its radius, for a three-dimensional configuration. In one advantageous embodiment, the wavelength or pitch of the flexing portion is at least four times that of its amplitude or radius. In another advantageous embodiment, the pitch increases as the flexing portion extends higher above the seafloor 16. The recurvate section both flexes resiliently in a direction generally perpendicular to its long axis, and expands and contracts in a direction parallel to its long axis, to accommodate the motion of the floating-body 22.

The flexing portion 30 enables a wellhead 14 to be connected directly to a floating platform 22 with single steel riser 10 without requiring either a flexible, reinforced elastomeric section of pipe, as illustrated in the prior art riser system of Fig. 1, and/or a catenary curve in the riser, as illustrated in Fig. 2. Further, since the steel of the risers can withstand the external compressive loads exerted by the environment, the need for reinforcement of a flexible elastomeric pipe section is also eliminated. Additionally, by eliminating the need for a catenary curve in the riser and its correspondingly greater weight, the need for the riser tension loads supported by the floating vessel are significantly.

It should be understood that the riser system 10 of the invention can be used in conjunction with many types of known platforms, including an FPSO platform, a TLP platform, a semi-submersible platform, or other types of such platforms that are known to those of skill in the art.

The characteristics of an exemplary vertical riser pipe 20 incorporating a flexing portion 30 having a sinusoidal configuration, such as that illustrated in Fig. 8, is shown in Table 1 below,

**Table 1 - Vertical Riser Pipe With Sinusoidal Flexible Portion**

No.	P	R	TL	OD	Wm	D/t	RF	RFr	St	Kr	PS <sub>ksi</sub>	PS <sub>psf</sub>	P <sub>ksf*100</sub>	L <sub>30ksi</sub>
1	30	2.0	210	6.625	0.4321	15.3	425.4	2.8	21.3	2.8	815.5	1.17E+08	1174.3	5708
2	30	3.4	210	6.625	0.4321	15.3	150.4	1.0	7.5	1.0	461.9	6.65E+07	665.1	3233
3	20	3.4	220	6.625	0.4321	15.3	135.5	0.9	6.8	0.9	411.0	5.92E+07	591.8	3014
4	40	3.4	200	6.625	0.4321	15.3	85.8	0.6	4.3	0.6	508.8	7.33E+07	732.7	3392
5	30	3.4	420	6.625	0.4321	15.3	72.1	0.5	3.6	0.5	228.3	3.29E+07	328.7	3196
6	30	5.0	210	6.625	0.4321	15.3	63.2	0.4	3.2	0.4	288.7	4.16E+07	415.8	2021
7	30	2.0	210	6.625	0.2161	30.7	235.4	1.6	11.8	1.6	844.3	1.22E+08	1215.8	5910
8	30	3.4	220	6.625	0.2161	30.7	75.0	0.5	3.7	0.5	425.4	6.13E+07	612.5	3119
9	40	3.4	200	6.625	0.2161	30.7	85.8	0.6	4.3	0.6	508.8	7.33E+07	732.7	3392
10	20	3.4	220	6.625	0.2161	30.7	75.0	0.5	3.7	0.5	425.4	6.13E+07	612.5	3119
11	30	3.4	420	6.625	0.2161	30.7	39.9	0.3	2.0	0.3	236.3	3.40E+07	340.3	3308
12	30	5.0	210	6.625	0.2161	30.7	34.0	0.2	1.7	0.2	298.9	4.30E+07	430.4	2092
13	30	3.4	210	8	0.5229	15.3	318.8	2.1	15.9	2.1	559.0	8.05E+07	805.0	3913

wherein,

$P$  = flexing portion wavelength, in feet;

- R** = flexing portion amplitude, in feet;
- TL** = total length of flexing portion, in feet;
- OD** = outer diameter of riser pipe, in inches;
- Wt** = wall thickness of riser pipe, in inches;
- 5 **D/t** = ratio of riser outer diameter to wall thickness;
- RF** = reaction force necessary to displace top of riser 20 feet;
- RFr** = normalization of reaction forces relative to straight pipe;
- K** = stiffness of riser;
- Kr** = normalization of stiffness relative to a straight pipe;
- 0 **PS<sub>ksi</sub>** = peak stress in riser, in kips per square inch;
- PS<sub>psf</sub>** = peak stress, pounds per square foot;
- PS<sub>ksi\*100</sub>** = peak stress, kips per square foot times 100; and,
- L<sub>30ksi</sub>** = length of a curved section necessary to limit maximum stress in riser to 30 ksi.

The characteristics of an exemplary vertical riser pipe 20 incorporating a flexing portion  
 5 30 with a helical configuration, such as that illustrated in Fig. 9, is shown in Table 2 below,

**Table 2 - Vertical Riser Pipe With Helical Flexing Portion**

No.	P	R	TL	OD	Wt	D/t	RF	RFr	St	Kr	PS <sub>ksi</sub>	PS <sub>psf</sub>	P <sub>ksi*100</sub>	L <sub>30ksi</sub>
1	30	3.4	240	6.625	0.4321	15.3	24.6	1.0	1.2	1.0	127.1	1.83E+07	183.0	1016.7
2	20	3.4	240	6.625	0.4321	15.3	19.5	0.8	1.0	0.8	85.1	1.23E+07	122.5	680.6
3	30	2	240	6.625	0.4321	15.3	84.6	3.4	4.2	3.4	294.4	4.24E+07	424.0	2355.6
4	30	5	240	6.625	0.4321	15.3	9.2	0.4	0.5	0.4	59.0	8.49E+06	84.9	471.7
5	40	3.4	240	6.625	0.4321	15.3	27.5	1.1	1.4	1.1	153.9	2.22E+07	221.6	1231.1
6	20	3.4	240	6.625	0.2161	30.7	10.8	0.4	0.5	0.4	88.1	1.27E+07	126.8	704.4
7	30	2	240	6.625	0.2161	30.7	46.9	1.9	2.3	1.9	304.9	4.39E+07	439.0	2438.9
8	30	3.4	240	6.625	0.2161	30.7	13.6	0.6	0.7	0.6	131.3	1.89E+07	189.0	1050.0
9	30	5	240	6.625	0.2161	30.5	5.1	0.2	0.3	0.2	61.0	8.79E+06	87.9	488.3
10	40	3.4	240	6.625	0.2161	30.7	15.3	0.6	0.8	0.6	159.0	2.29E+07	229.0	1272.2
11	30	3.4	240	8	0.5229	15.3	52.1	2.1	2.6	2.1	153.6	2.21E+07	221.3	1229.2

wherein,

- P** = flexing portion pitch, in feet;
- R** = flexing portion radius, in feet;
- 20 **TL** = total length of flexing portion, in feet;
- OD** = outer diameter of riser pipe, in inches;
- Wt** = wall thickness of riser pipe, in inches;
- D/t** = ratio of riser pipe outer diameter to wall thickness;
- RF** = reaction force necessary to displace top of riser 20 feet;
- 25 **RFr** = normalization of reaction forces relative to a straight pipe riser;
- K** = riser stiffness;
- Kr** = normalization of riser stiffness relative to a straight pipe riser

$PS_{ksi}$  = peak stress, kips per square inch;

$PS_{psf}$  = peak stress, pounds per square foot;

$PS_{ksf*100}$  = peak stress, kips per square foot times 100; and,

$L_{30ksi}$  = length of flexing portion necessary to limit maximum stress in riser to 30 ksi.

5 An important advantage provided by the flexing portions 30 is the additional “layer” of safety that they afford to the structural integrity of the entire riser system 10. If, for example, the top end of the riser pipe 20 should move beyond its normal operating design limits, either horizontally or vertically, the flexing portions will responsively expand or contract, without local buckling, and thereby maintain the structural integrity of the riser. This situation might occur if, for example, the surface vessel 22 were to lose buoyancy due to a damaged tank, or if it should  
10 inadvertently slip its moorings.

In addition to the riser pipe characteristics shown in Tables 1 and 2 above, a number of additional design factors should be considered in developing a site-specific riser system 10 design. These additional factors include:

- 15
- Water depth;
  - Envelope of surface vessel motion;
  - Physical properties of the riser;
  - Ocean currents;
  - Envelope of deflection curve of the riser to avoid riser collisions;

20

  - Method of installation and removal of riser; and,
  - Limitation of riser curvature to allow passage of through-tubing tools (*e.g.* “pigs”).

As illustrated in Fig. 10, the benefits of the flexing portions 30 can be advantageously combined with those of the riser systems 10 having elbows described above in connection with Figs. 4 and 5. In Fig. 10, a flexing portion has been incorporated in the vertical pipe section 20, such that movements of the floating platform 22 are accommodated by flexure of the horizontal and vertical sections of pipe in a direction perpendicular to their respective longitudinal axes, as well as by flexure of the flexing portion in a direction parallel to its longitudinal axis. Embodiments of riser systems incorporating a flexing portion in the horizontal, vertical, and both the horizontal and vertical pipe sections of the riser are illustrated schematically in Figs. 11, 12 and  
25  
30 13, respectively.

As will by now be apparent to those of skill in the art, many modifications, alterations and substitutions are possible to the materials, methods and configurations of the riser systems of the present invention without departing from its spirit and scope. Accordingly, the scope of the present invention should not be limited to the particular embodiments described and illustrated  
5 herein, as these are merely exemplary in nature. Rather, the scope of the present invention should be commensurate with that of the claims appended hereafter, and their functional equivalents.

## CLAIMS

## WHAT IS CLAIMED IS:

1. An offshore oil well riser system extending from a floating vessel on the sea surface to a sub-sea well equipment located on the sea floor, the riser system comprising:
  - 5 an elongated, substantially vertical section of pipe supported by the floating body and extending downward towards the sea floor;
  - an elongated, substantially horizontal section of pipe connected to the sub-sea well equipment;
  - an angled elbow section of pipe connecting the vertical pipe section to the horizontal pipe
  - 10 section such that the vertical and horizontal pipe sections resiliently flex in a direction generally perpendicular to their respective long axes in response to motion of the floating vessel. and,
  - an elongated flexing portion of pipe disposed axially within at least one of the vertical and the horizontal pipe sections and arranged therein to resiliently flex in directions both generally perpendicular and parallel to its long axis in response to motion of the floating vessel.
- 15 2. The riser system of claim 1, wherein the flexing portion of pipe comprises a plurality of recurvate sections of pipe connected end-to-end with alternating curvatures.
3. The riser system of claim 1, wherein the flexing portion of pipe is disposed in the vertical, the horizontal, or both the vertical and the horizontal sections of pipe.
4. The riser system of claim 1, wherein a central axis of the flexing portion of pipe lies in
- 20 a single plane.
5. The riser system of claim 1, wherein the flexing portion pipe is generally sinusoidal in shape.
6. The riser system of claim 1, wherein the flexing portion of pipe is generally helical in shape.
- 25 7. The riser system of claim 1, wherein the flexing portion of pipe has a two-dimensional shape.

8. The riser system of claim 1, wherein the flexing portion of pipe has a three-dimensional shape.

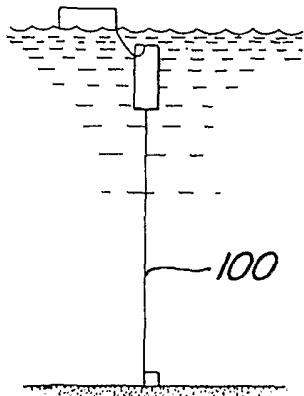

**FIG. 1**  
PRIOR ART

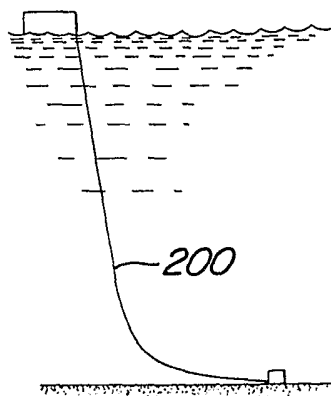

**FIG. 2**  
PRIOR ART

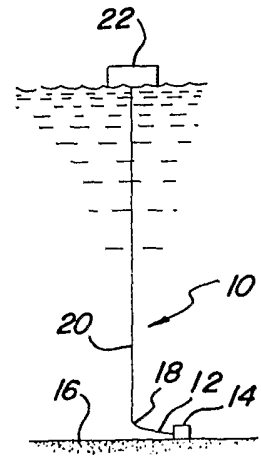

**FIG. 3**

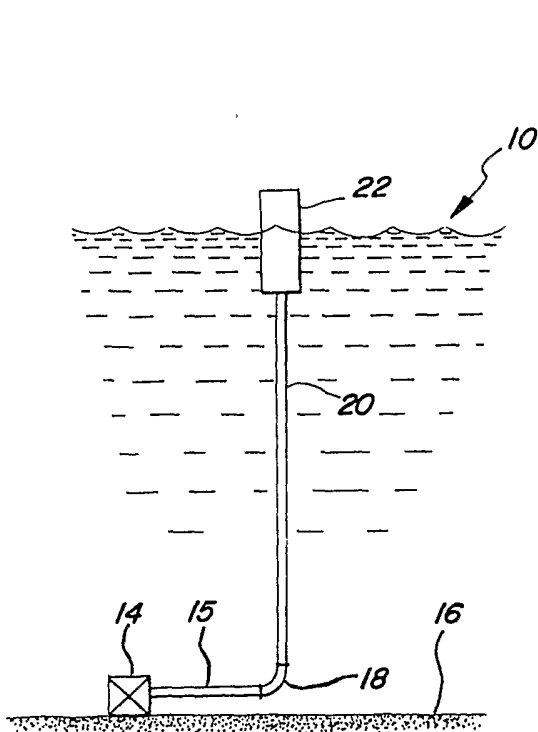

**FIG. 4**

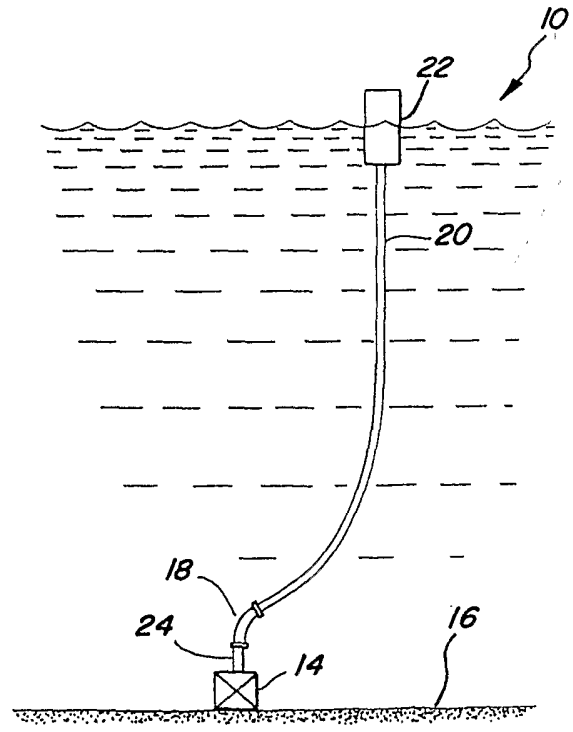

**FIG. 5**

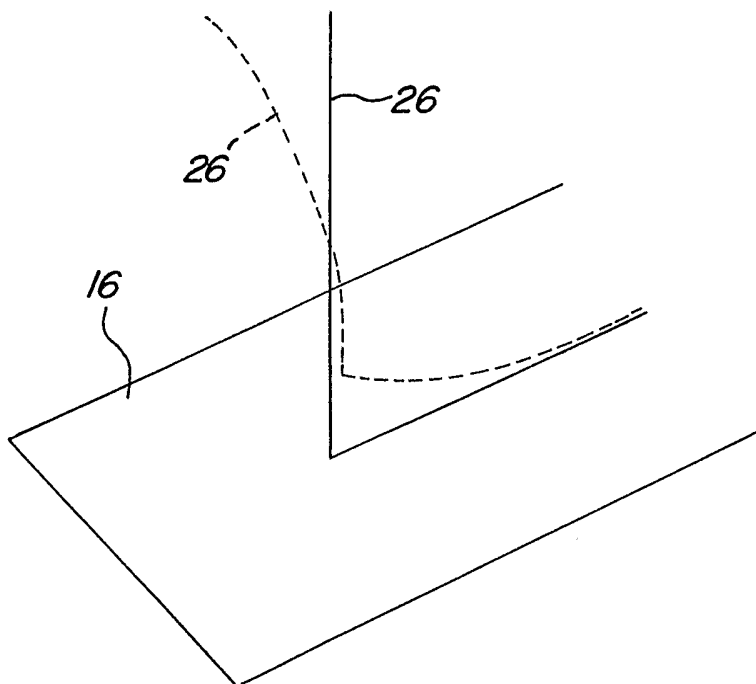

**FIG. 6**

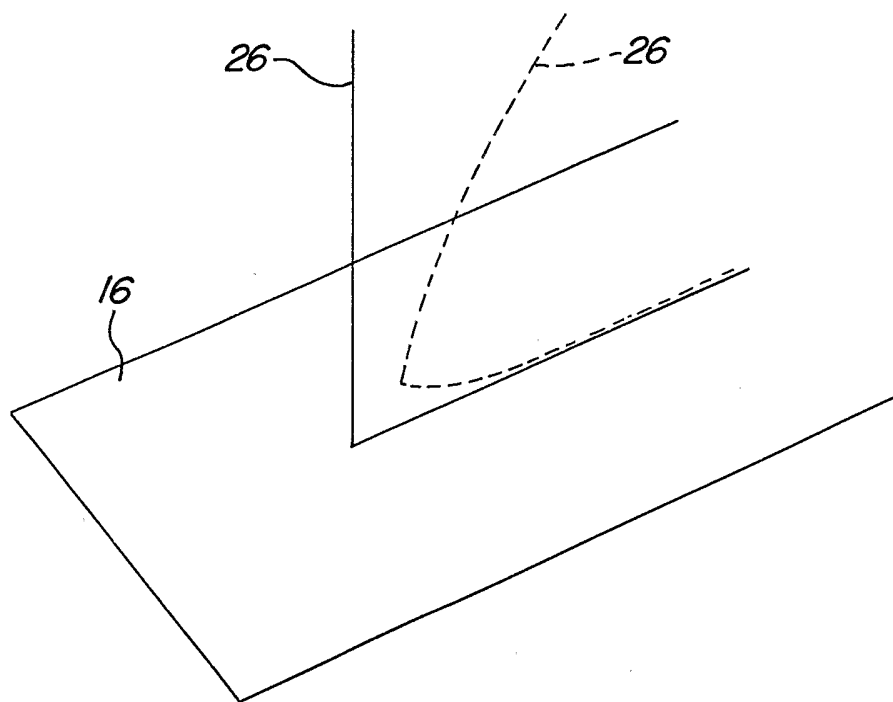

**FIG. 7**

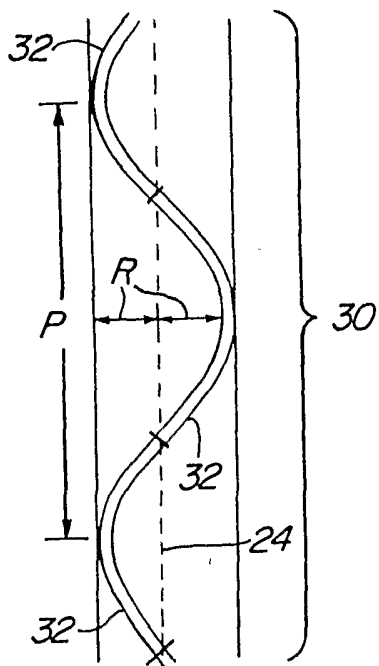

FIG. 8

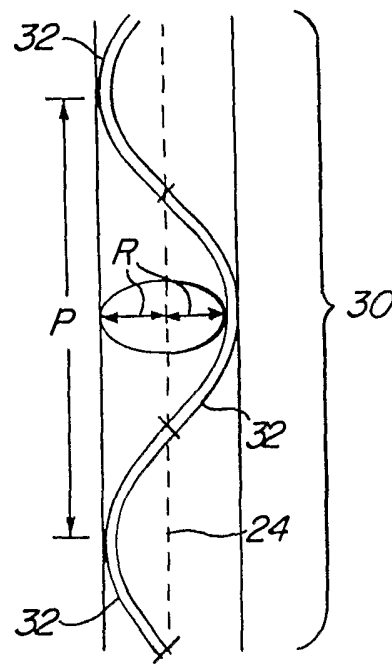

FIG. 9

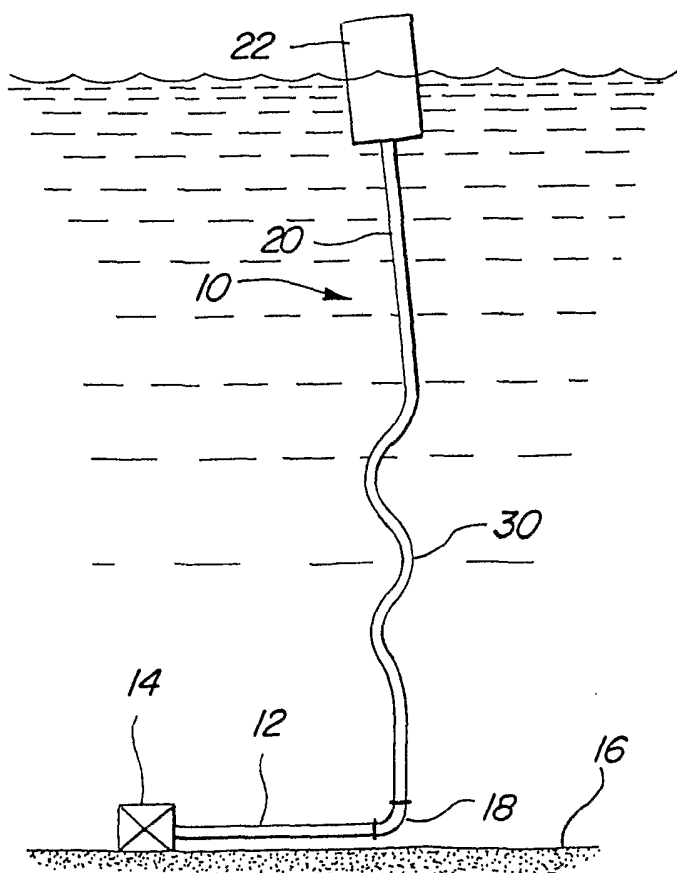
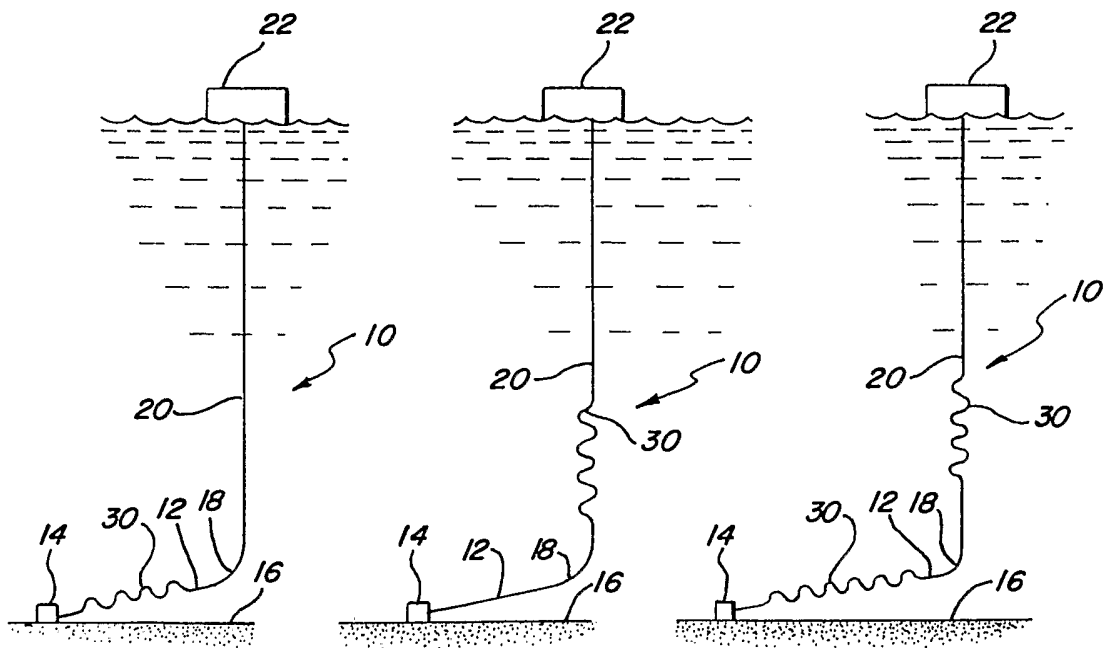

FIG. 10



**FIG. 11**

**FIG. 12**

**FIG. 13**