

H. G. BALLOU.

TRUSS.

APPLICATION FILED AUG. 7, 1908.

968,728.

Patented Aug. 30, 1910.

2 SHEETS—SHEET 1.

FIG. 1.

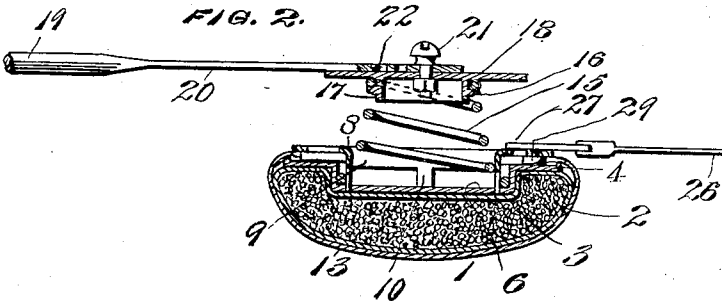
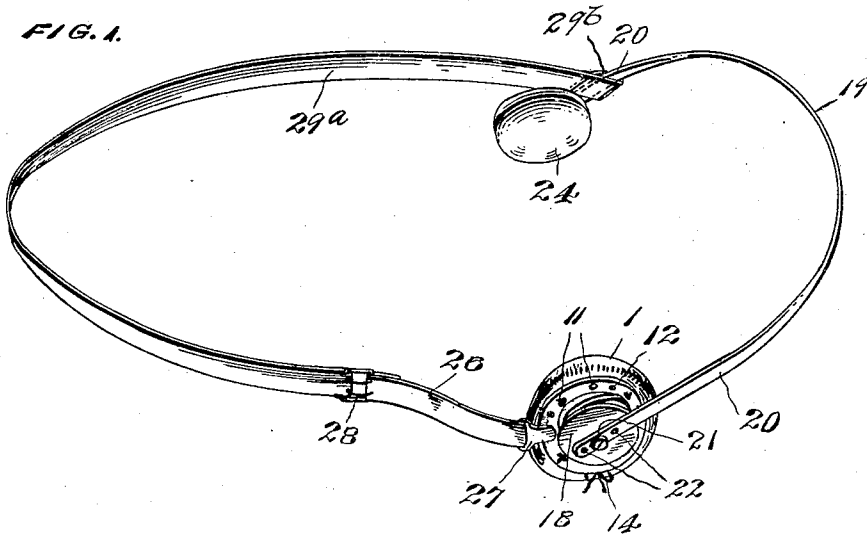

FIG. 3.

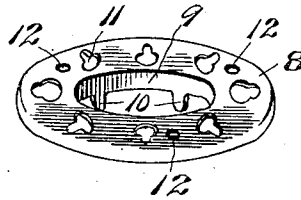

FIG. 5.

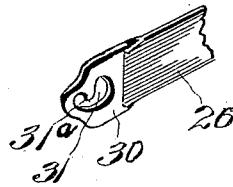
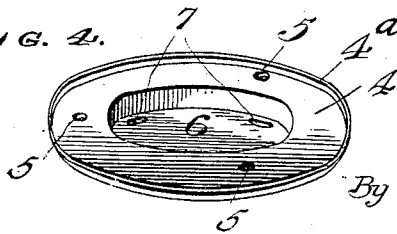

FIG. 4.



WITNESSES
Chas. N. Davies.
J. Stewart Rice.

INVENTOR
H. G. Ballou,
By C. L. Parken,
Attorney.

H. G. BALLOU.
 TRUSS,
 APPLICATION FILED AUG. 7, 1908.

968,728.

Patented Aug. 30, 1910.

2 SHEETS—SHEET 2.

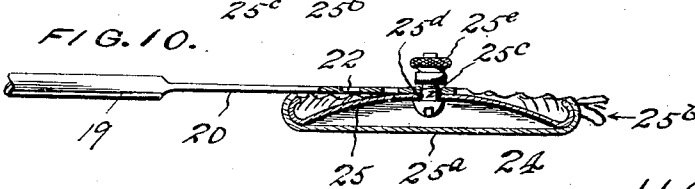
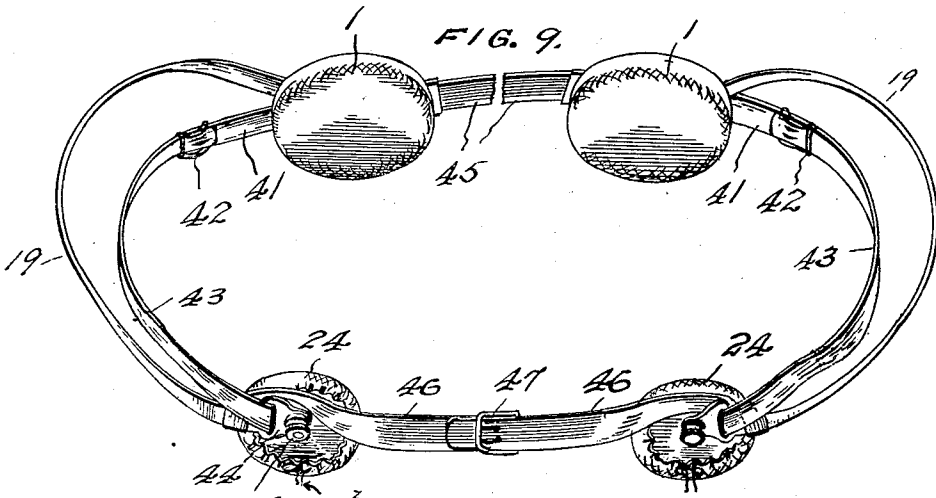
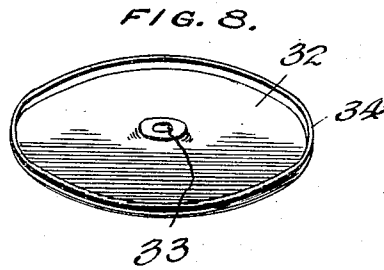
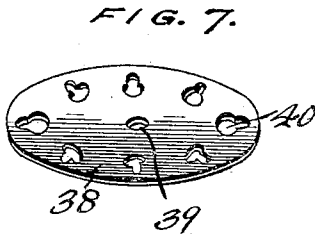
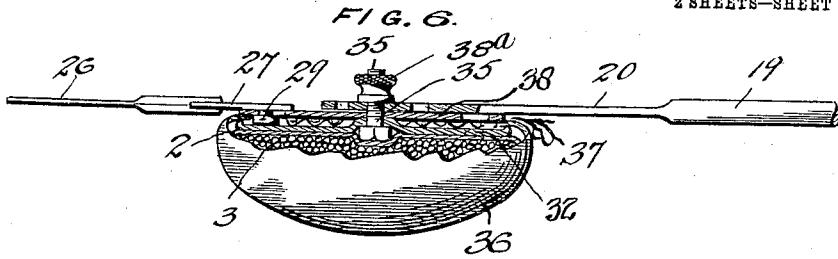

WITNESSES
 Chas. N. Davis
 Stewart Rice.

H. G. Ballou,
 INVENTOR
 by C. L. Parker,
 Attorney

UNITED STATES PATENT OFFICE.

HARRY G. BALLOU, OF SEATTLE, WASHINGTON.

TRUSS.

968,728.

Specification of Letters Patent. Patented Aug. 30, 1910.

Application filed August 7, 1908. Serial No. 447,450.

To all whom it may concern:

Be it known that I, HARRY G. BALLOU, a citizen of the United States, residing at Seattle, in the county of King and State of Washington, have invented certain new and useful improvements in Trusses, of which the following is a specification.

This invention relates to improvements in trusses, and has for its object to provide a truss, which while held positively against the rupture, to prevent slipping, will nevertheless exert an easy and elastic pressure thereagainst.

Another object of my invention is to provide a filling for the front pads, which possesses marked advantages over those heretofore employed.

Other objects and advantages of my invention will appear in the following specification.

In the accompanying drawing, Figure 1 is a perspective view of my improved truss, as employed for a single hernia, showing the sustaining means employed to position the same; Fig. 2 is a cross sectional view (enlarged) through the front pad and showing how the hip spring is connected thereto; Fig. 3 is a perspective view of the clamping plate or disk. Fig. 4 is a perspective view of the foundation plate or disk. Fig. 5 is a modified form of fastening means. Fig. 6 shows a modified form of the means employed to mount and hold the front pad in position. Fig. 7 shows a modified form of clamping plate or disk. Fig. 8 shows a modified form of foundation plate. Fig. 9 is a perspective view of my improved truss adapted to serve as a double truss together with the sustaining means employed, and, Fig. 10 is a cross section (enlarged) through one of the rear pads, and showing the method of connecting the hip spring thereto.

Referring to the drawings, which illustrate the preferred form of my invention, 1 designates the front pad, which has therein a small circular sack of leather, cloth or other pliable material 2 loosely filled with a granular material 3, as for instance, mustard seed or other material of greater or less degree of coarseness, which will not "cake" by reason of being subjected to the moisture exhaled from the pores of the skin, and hence will not constitute an irritating, hard or dense pad. The pad will also be cool and soft, because the heat of the body transmit-

ted to it will be readily diffused and dissipated by the granular filling.

Adapted to be seated upon the sack 2, is a metal plate or disk 4, which for convenience of description will be termed the foundation plate or disk. This plate has a central countersunk portion 6 in the bottom of which are formed several slots 7, while that portion of the plate surrounding the countersunk portion has several small perforations 5, which are threaded. The circumferential edge of the foundation plate is turned up as shown at 4^a.

Upon the foundation plate 4 a second plate or disk 8 is adapted to be seated, which second disk constitutes a clamping plate. This clamping plate has its outer edge turned over, as shown, and has a central opening therein from which depends a circular flange 9 provided with several lugs or projections 10, which are adapted to enter the slots 7 in the countersunk portion 6 of the foundation plate 4. The face of the clamping plate is provided with a plurality of apertures 11, which are preferably of the keyhole type, as shown. In the face of the plate 8 there are also several small circular perforations 12, which are threaded and designed to register with the perforations 5 in the foundation plate 4 and the two plates are thus held together by short screws passing through the perforations.

The pad is provided with an outer cover 13 of leather, cloth or other soft, pliable material. This cover is designed to be drawn over the sack 2 by means of a draw string 14 and firmly held by the outer edges of the clamping plate 8 overlapping the edges of the cover. By reason of the upturned edges of the foundation plate the degree of tightness to which the cover 13 can be drawn over the sack 2 can be regulated, that is the draw string 14, can be drawn to make the cover 13 as tight as desired, thereby compressing the granular filling 3 in the sack 2 to make the pad as hard as desired, and then the clamping plate 8 can be fastened to the foundation plate 4, which will firmly hold the cover as tight as it is drawn by the draw-string.

A spiral spring 15 with its lower convolution secured between the wall of the countersunk portion 6 of the foundation plate 4 and the projections or lugs 10 of the clamping member is designed to have its

upper end or convolution sprung into and held by spring action in a groove 16 formed in a depending circular rib or projection 17, which is either fixedly attached to or forms
 5 an integral part of a plate or disk 18.

A bow-shaped hip spring 19, which is substantially cylindrical in cross section, but flattened at its ends, as at 20, 20, is adapted to have one of its ends secured by means of a headed bolt 21 to the plate 18.
 10 Each end of the hip spring is provided with several perforations 22, as shown, so that an adjustment of the front and rear pads can be effected to fit the truss to the wearer. A
 15 back pad 24, see Fig. 10, is adapted to be secured to the other end of the hip spring 19. The back pad 24 consists of a dished plate 25, the circumferential edge of which is turned up as shown, and a cover 25^a of
 20 leather, cloth or other suitable material secured by means of a draw-string 25^b. The back pad is secured to the hip spring by means of a headed bolt 25^c, the threaded end of which is projected through a centrally
 25 arranged aperture 25^d in the plate 25 and then through the selected perforation 22 in the end of the hip spring to which it is secured by a nut 25^e.

My form of hip spring possesses advantages over those heretofore employed, as it is substantially cylindrical at its central
 30 portion to lend strength, and rigidity where needed and flattened for some distance from the point of engagement with the front and
 35 back pads thereby readily admitting of a lateral flexibility, but resisting any movement up or down.

While it will be noted that both ends of the hip spring are shown as flattened, it is evident that I may flatten only one end, and this could be the end connected to either the
 40 front or back pad as desired. This will cause a decrease in the flexibility of the hip spring, which, under some circumstances will prove desirable.

While the pad 1 will, under normal conditions, be held in position by the elasticity of the hip spring 19 I deem it advisable, under certain conditions, as in the case of a
 50 severe hernia, to employ a strap as an additional sustaining means. This strap consists of a short strap 26, preferably of elastic fabric, provided with a tab 27 at one end and a buckle 28 at the other. This tab 27
 55 is provided with a headed pin or stud 29 adapted to be inserted in the enlarged part of the opening of one of the key-hole slots 11, and held in said slot by being drawn over to the reduced portion by the contraction of the elastic strap 26. Adapted to be
 60 secured to said buckle is a non-elastic fabric strap 29^a, which has its other end connected at 29^b to the bow-shaped hip spring 19 thereby forming an adjustable girth strap
 65 for the wearer. By this arrangement the

short elastic straps 26, which wear out much sooner than the plain fabric ones can be replaced at little cost.

In Fig. 5 a modified form of tab, as 30, is shown provided with a curved slot 31
 70 which is slightly reduced at its lower end, and has a projection 31^a therein, which partially closes or divides said slot to retain therein the projection engaged. In this form the tabs are designed to be hooked over
 75 the headed bolt 21 and will be readily retained thereon against accidental displacement.

From the foregoing it will be obvious that I have produced a truss, which can be
 80 readily applied with equal facility to a rupture on either the right or the left hand side, and which will be comfortable to the wearer and efficacious in the reduction of
 85 the hernia.

While I have shown the front pad 1 as being connected to the bow-shaped hip spring 19 by means of the coil spring 15 it is obvious that the pad can be connected directly to the hip spring, as shown in Fig.
 90 6. In this form the foundation plate 32 is a flat disk provided with a central aperture 33, the under edge of which is bent upward as shown. The circumferential edge of the foundation plate is turned up as indicated
 95 at 34. The foundation plate is adapted to be seated upon the sack 2 with a headed bolt 35 having its threaded end projected through the aperture 33. A cover 36 is then placed over the sack 2 filled with granular
 100 material 3 and drawn over the upturned edge 34 of the foundation plate 32, and drawn as tightly as desired by a draw string 37 and then a clamping plate 38 provided with a central aperture 39 and keyhole slots
 105 40 is positioned thereon with the threaded end of the bolt 35 passing through said aperture 39 and all held thus assembled by a milled nut 38^a.

In Fig. 9 I have shown a double form of
 110 truss, which is adapted to be worn by a person afflicted with a double hernia. In this form two front pads are employed which may be of the type in which the coil spring is interposed between the pad and the hip
 115 spring, as in Figs. 1 and 2, or of the form where the coil spring is interposed on one side only, while on the other side the front pad is connected directly to the hip spring, as in Fig. 6, or both front pads can be connected
 120 directly to the hip springs. In the less severe hernias it would probably be best to employ the form where the front pads have a spring interposed between the pad and the hip spring, thereby avoiding any undue
 125 pressure on the affected parts.

In the double form of truss, shown in Fig. 9, I have shown side straps connecting the front and rear pads. These side straps each consist of a short piece of fabric 41,
 130

preferably elastic, provided with a buckle 42 by which they can be attached to a strip of non-elastic fabric 43, which has a perforated tab 44 at its free end by which it is 5 connected to the rear pad by means of the bolt 25^c. The strips 41 carry tabs, either of the type designated by 27 provided with a headed pin 29 for engagement with the key-hole slots of the clamping plate or of the 10 form shown in Fig. 5 to engage the bolt 21 of the front pad, as in Fig. 2, or the bolt 35, as in Fig. 6. The front pads are designed to be connected together by two strips of fabric 45, 45, elastic if desired, which are 15 suitably secured to the front pads and are adjustably connected together by a buckle, not shown, carried by one of the strips. The hip springs 19, 19, are connected together near their juncture with the back pads by 20 back straps 46, 46, one of which carries a buckle 47 by means of which the straps may be adjusted. As is apparent the back and front straps will prevent the hip springs from becoming displaced. In connection 25 with the double form of truss it is apparent that any and all of the straps may be omitted, as the condition of the hernias of the wearer will admit, as the hip springs will, by reason of their shape and elasticity, 30 maintain the pads in their proper positions, but with the use of the straps they will of course, be held firmer and thus secure against accidental displacement.

Having thus described my invention, I 35 claim,

1. In a truss, a hip spring, pads arranged upon said hip spring, one or both of said pads comprising a foundation plate provided with a countersunk portion, a second plate

arranged upon said first named plate and 40 being provided with a portion to fit within said countersunk portion, a coiled spring having a portion thereof arranged within 45 said countersunk portion and around the outer side of said portion of said second named plate adapted to fit within said coun- 45 tersunk portion, means for securing one end of said spring to said hip spring and means for securing said first and second named 50 plates together, substantially as described.

2. In a truss, a hip spring, a pad arranged upon said hip spring, said pad comprising a sealed casing, light non-metallic spheres arranged within said casing for forming the 55 filling therefor, a plate arranged upon said casing, a covering of flexible material surrounding said casing and arranged upon said 55 plate, means for adjusting the size of said covering, and a plate for holding said covering in such adjusted position, substantially 60 as described.

3. In a truss, a hip spring, a pad arranged upon said hip spring, said pad comprising a sealed casing, seeds arranged within said casing for forming the filling therefor, a 65 plate arranged upon said casing, a covering of flexible material surrounding said casing and arranged upon said plate, means for adjusting the size of said covering, and a 70 plate for clamping said covering in such adjusted position, to said first named plate, substantially as described.

In testimony whereof I affix my signature in presence of two witnesses.

HARRY G. BALLOU.

Witnesses:

V. A. PETERSON,
L. W. BRUNDAGE.