

T. CONELEY.

Improvement in Churns.

No. 128,364.

Patented June 25, 1872.

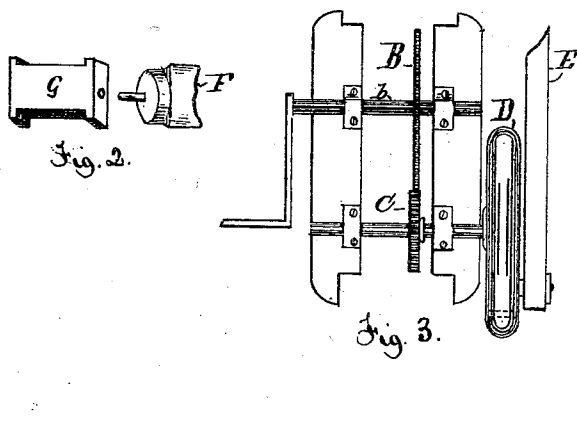
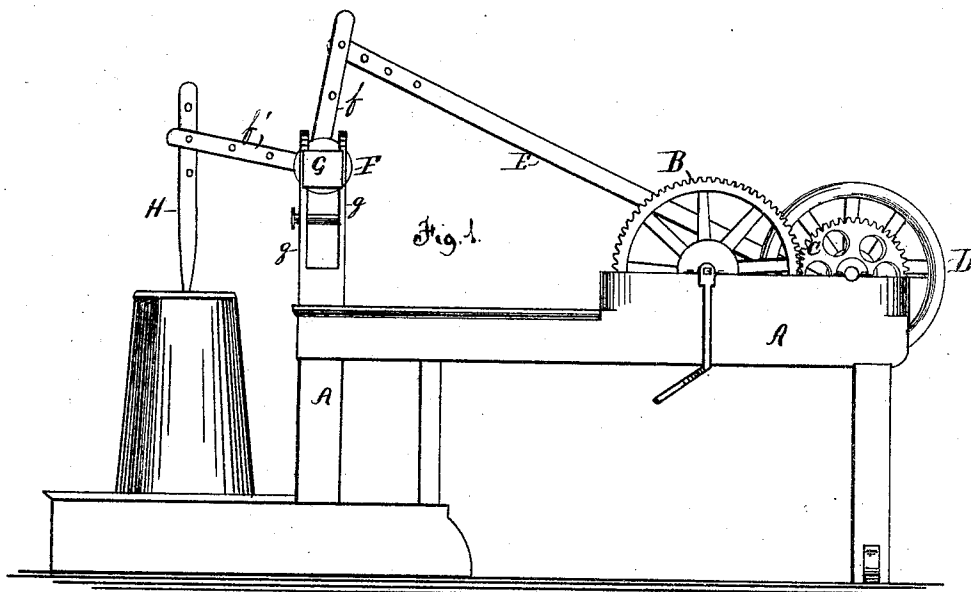

WITNESSES.

H. Carlin Letart.
S. J. Hayes.

INVENTOR.

Thomas Coneley by
Dyer, Beadle & Co.
attys.

UNITED STATES PATENT OFFICE.

THOMAS CONELEY, OF GRAFTON, ILLINOIS.

IMPROVEMENT IN CHURNS.

Specification forming part of Letters Patent No. 128,364, dated June 25, 1872.

SPECIFICATION.

To all whom it may concern:

Be it known that I, THOMAS CONELEY, of Grafton, in the county of McHenry and State of Illinois, have invented a new and useful Improvement in Churn; and I do hereby declare that the following is a full and exact description of the same, reference being had to the accompanying drawing and to the letters of reference marked thereon.

This invention relates to that class of devices for operating churns which give a vertical movement to the dasher by means of the revolution of a crank; and consists mainly in the specific construction, by means of which it is adjusted to suit different sizes of churns, as will be fully described hereinafter.

In the drawing, Figure 1 represents a side elevation of my improved machine; and Figs. 2, 3, and 4, views of parts detached.

To enable others skilled in the art to make and use my invention, I will now proceed to describe fully its construction and manner of operation.

A A represents the frame-work of the machine, consisting of suitable beams supported upon proper legs, as shown in the drawing. B represents the main driving-wheel, having the shaft *b*, turning in suitable bearings in the frame, which shaft is provided with a crank or other proper means for receiving motion. The periphery of the wheel B is provided with suitable teeth, which engage with the teeth of the smaller wheel C, the shaft of which latter is provided at one end with the fly-wheel D, to which is attached one end of the connecting-rod E, as shown. This connecting-rod is attached at its opposite end to a slotted arm, *f*, of the rocking shaft F, which latter is supported by bearings in the sliding boxes G, held in the slotted beams *g g*, as shown. *f'* also represents a slotted arm attached to the rocking shaft at right angles to the arm *f*. H represents the churn-dasher, which is connected by means of a pin to the arm *f'*. The churn itself rests upon a suitable platform below the arm, as shown.

The connecting parts of this churn are made readily adjustable in order that it may be adapted to suit any size of churn. The con-

necting-rod E may be adjusted upon the fly-wheel nearer to or further from its center, in order to shorten or lengthen its throw as may be desired. This result is accomplished by changing the screw-bolt which secures it in place from one orifice to another, as indicated in Fig. 3. The opposite end of the connecting-rod may be attached to the arm *f* of the rocking shaft, to make it longer or shorter, at any desired point, it being provided for that purpose with a series of orifices, as shown.

The position of the rod E in the slot of the arm *f* may be varied at will by means of the series of orifices and the securing-pin, by which means the length of the movement of the rocking shaft is determined. The arm *f'* is also provided with a series of openings, so that the dasher may be adjusted to have a longer or shorter stroke in the churn, or operate in a line nearer or more remote from the frame-work. The vertical position of the dasher may also be adjusted by means of the series of holes in its rod. The position of the rocking shaft vertically may also be adjusted by moving the sliding boxes in the slotted supporting-beams *g g*.

By means of the construction described the mechanism is adapted to be adjusted to any size of churn. The power is advantageously applied, and consequently excellent results are obtained from its operation.

I do not claim the adjustability of the parts separately; but

Having thus fully described my invention, what I claim as new, and desire to secure by Letters Patent, is—

1. In a churn, the combination of the rocking shaft with the sliding boxes G in the slotted beams, as described.

2. The combination of the adjustable wrist-pin in the fly-wheel D, the adjustable connecting-rod F, the bent lever with adjustable arms *f f'*, the sliding boxes *g g*, and the adjustable dasher-rod, as described.

This specification signed and witnessed this 13th day of April, 1872.

THOMAS CONELEY.

Witnesses:

A. C. BELCHER,
C. E. BEST.