



## INTERNATIONAL APPLICATION PUBLISHED UNDER THE PATENT COOPERATION TREATY (PCT)

<p>(51) International Patent Classification <sup>5</sup> : <b>B01D 53/04</b></p>	<p><b>A1</b></p>	<p>(11) International Publication Number: <b>WO 91/14496</b> (43) International Publication Date: 3 October 1991 (03.10.91)</p>
<p>(21) International Application Number: PCT/US91/01876 (22) International Filing Date: 19 March 1991 (19.03.91) (30) Priority data: 496,484 20 March 1990 (20.03.90) US (71) Applicant: W.L. GORE &amp; ASSOCIATES, INC. [US/US]; 551 Paper Mill Road, P.O. Box 9206, Newark, DE 19714 (US). (72) Inventors: DAUBER, Edwin, George ; 60 Leicester Way, Chesapeake City, MD 21915 (US). BAILEY, Christian, Edward ; 700 Principio Road, Port Deposit, MD 21904 (US). SASSA, Robert, Louis ; 1 Francis Circle, Newark, DE 19711 (US).</p>		<p>(74) Agents: WEKER, Dena, Meyer et al.; W.L. Gore &amp; Associates, Inc., 551 Paper Mill Road, P.O. Box 9206, Newark, DE 19714 (US). (81) Designated States: AT (European patent), BE (European patent), CA, CH (European patent), DE (European patent), DK (European patent), ES (European patent), FR (European patent), GB (European patent), GR (European patent), IT (European patent), JP, LU (European patent), NL (European patent), SE (European patent). <b>Published</b> <i>With international search report.</i> <i>Before the expiration of the time limit for amending the claims and to be republished in the event of the receipt of amendments.</i></p>
<p>(54) Title: AN ADSORBENT ASSEMBLY FOR REMOVING GASEOUS CONTAMINANTS</p>		
<div style="text-align: center;"> </div>		
<p>(57) Abstract</p> <p>An adsorbent assembly is provided for removing gaseous contaminants from an enclosure having one or more layers of an adhesive, at least one layer of an adsorbent material and a layer of filtering material, wherein the adsorbent layer is located between the adhesive layer and filtering layer. The assembly is very thin and adheres to an interior wall of an enclosure.</p>		

**FOR THE PURPOSES OF INFORMATION ONLY**

Codes used to identify States party to the PCT on the front pages of pamphlets publishing international applications under the PCT.

AT	Austria	ES	Spain	MG	Madagascar
AU	Australia	FI	Finland	ML	Mali
BB	Barbados	FR	France	MN	Mongolia
BE	Belgium	GA	Gabon	MR	Mauritania
BF	Burkina Faso	GB	United Kingdom	MW	Malawi
BG	Bulgaria	GN	Guinea	NL	Netherlands
BJ	Benin	GR	Greece	NO	Norway
BR	Brazil	HU	Hungary	PL	Poland
CA	Canada	IT	Italy	RO	Romania
CF	Central African Republic	JP	Japan	SD	Sudan
CG	Congo	KP	Democratic People's Republic of Korea	SE	Sweden
CH	Switzerland	KR	Republic of Korea	SN	Senegal
CI	Côte d'Ivoire	LI	Liechtenstein	SU	Soviet Union
CM	Cameroon	LK	Sri Lanka	TD	Chad
CS	Czechoslovakia	LU	Luxembourg	TG	Togo
DE	Germany	MC	Monaco	US	United States of America
DK	Denmark				

-1-

AN ADSORBENT ASSEMBLY FOR REMOVING GASEOUS CONTAMINANTS

**FIELD OF THE INVENTION**

This invention relates to a thin compact self-adhesive adsorbent assembly having one or more layers of adhesive, one or more layers of adsorbent or reactant material, and a layer of filter material which retains the adsorbent material, and is permeable to gases and selected liquids but impermeable to large size materials.

**BACKGROUND OF THE INVENTION**

Many enclosures that contain sensitive instrumentation must maintain very clean environments in order to keep that instrumentation running properly. Examples include enclosures with sensitive optical surfaces, electronic connections and magnetic data storage surfaces on computer hard disk drives. Contaminants to these surfaces may be either particulate or gaseous in nature insomuch as they interfere with the proper operation of the equipment, and may enter the enclosure from the outside environment or be generated within the enclosure such as by outgassing of components.

Filtration devices to keep particulate from entering these enclosures are well known. They may consist of a filtration media held in place by a housing of polycarbonate, acrylonitrile butadiene styrene, or some other material; or they may consist of a filtration media in the form of a self-adhesive disk utilizing a layer or layers of pressure sensitive adhesive. These devices are mounted and sealed over a vent hole in the enclosure to filter the air entering the enclosure. Filtration performance depends not only on the filter having a high filtration efficiency but also on having a low resistance to air flow so that unfiltered air does not leak into the enclosure through a gasket or seam instead of entering through the filter.

Cartridges that contain adsorbents or reactants to remove gas or vapor impurities are also well known. They may consist of an adsorbent material held in place by a housing of polycarbonate, acrylonitrile butadiene styrene, or other material which also utilizes a filtration media that allows the exchange of gases in and out of the adsorbent cartridge while preventing the adsorbent

material from becoming a source of particulate contamination. A preferred configuration of the adsorbent cartridge is to have the adsorbent completely encapsulated by the filtration media such as in a tube of pure expanded polytetrafluoroethylene as described in U.S. Patent 4,830,643.

Another constraint, however, in many enclosures is space. The sensitive instrumentation is continually being miniaturized and put in smaller and smaller enclosures. In some cases this compounds the contamination problem as surfaces become more sensitive and closer together such as in computer hard disk drives where particulates, hydrocarbon gases, acid gases, and solvent vapors become more of a problem as read/write head flying heights become smaller and more sensitive higher density thin film recording media are employed.

Breather filters that are constructed of only filter media and a self-stick adhesive are ideal for these applications as they can be made very thin and small in size. Adsorbent cartridges or tubes, however, take up valuable space in these enclosures, and when they are used, they often must be put into a corner away from the most sensitive surfaces because of space constraints.

One solution of these problems is the combination of an adsorber breather filter. These can be made by filling a cartridge of polycarbonate, acrylonitrile butadiene styrene, or some other material with adsorbent and securing filter media on both ends of the cartridge and attaching said cartridge to the enclosure which needs a controlled environment. This allows air to enter the enclosure through the adsorbent to clean the air that enters the enclosure. Gas or vapor contaminants that outgas or originate from sources inside the enclosure can be captured by the adsorbent by diffusing through the filter media into the adsorbent material. These cartridges also take up space although they can be mounted outside the enclosure. Outside mounting, however, raises problems of rigidity and sturdiness as a filter that protrudes from the enclosure is subject to easier damage.

A second combination adsorbent breather filter is also available that encapsulates the adsorbent material between two layers of filter media and is applied to the enclosure with a layer of self-stick adhesive.

Both of these above-mentioned adsorbent breather configurations, however, have two major drawbacks. First, since they utilize two layers of filter media and a layer of adsorbent material, they suffer from a fairly high resistance to air flow. As mentioned earlier, filtration performance in a breather filter depends in part upon the filter having a low resistance to air flow such that unfiltered air is not forced or allowed to leak through gaskets or seams that might open up under higher pressure. Secondly, since they are located directly under or over a vent hole into the enclosure, one side of the adsorbent breather faces the outside atmosphere and the adsorbent can become more quickly spent or saturated with gaseous contaminants.

There is need for a system that minimizes space requirements for adsorbent, and has a long lasting adsorbent that is easily mounted proximate to the critical areas of enclosures housing sensitive instrumentation.

#### SUMMARY OF THE INVENTION

This invention provides a self-stick adsorbent assembly having a low profile container for selectively adsorbing gaseous components comprising one or more layers of adhesive one or more layers of adsorbent or reactant material and a layer of filtering material.

The assembly provides a means for continually depleting the air of unwanted contaminating gases by providing a means for adsorbing these unwanted gases without limiting the performance of other particulate filtration devices and by placing the device proximate to the critical areas that require protection and as far away as possible from the outside atmosphere.

#### BRIEF DESCRIPTION OF THE DRAWINGS

Figure 1 is a simplified schematic drawing of the interior of a disk drive enclosure showing the adsorbent assembly.

Figure 2 is a top view of the adsorbent assembly.

Figure 2a is a cross-sectional view of the assembly taken along line A-B.

Figure 3 is a top view of a second embodiment.

Figure 3a is a cross-sectional view of this embodiment taken along line C-D.

Figure 4 is a top view of a third embodiment of the present invention.

Figure 4a is a cross-sectional view of this embodiment taken along line E-F.

Figure 5 is a top view of a fourth embodiment of the present invention.

Figure 5a is a cross-sectional view of this embodiment taken along line G-H.

Figure 6 is a top view of a fifth embodiment of the present invention.

Figure 6a is a cross-sectional view of Figure 6 along line I-J.

#### DETAILED DESCRIPTION OF THE PREFERRED EMBODIMENTS

The present invention provides a very thin adsorbent filter assembly that is self-adhering for use within the interior enclosure of a computer disk drive that is capable of removing contaminants within the enclosure. Because of the novel features of the assembly, specifically its thin dimensions, contaminants are easily removed without any interference of the operation of the disk drive. Referring to Figure 1, the thin adsorbent assembly 20 is located at a site of concentrated contaminants where it is capable of removing contaminants. Figure 1 also shows the magnetic storage disk 21, read/write head 22, and armature 23 to control position of read/write head. Gaseous contaminants that may be of concern include but are not limited to dioctylphthalate, chlorine, hydrogen sulfide, nitrous oxide, mineral acid gases, and vapors from silicone, hydrocarbon based cutting oils, and other hydrocarbon pollutants. In general, the filter assembly will have at least one layer of adhesive, at least one layer of adsorbent material and one layer of filter material.

The adhesive layer may be either a single layer of transferable adhesive or a double-sided adhesive coated onto a carrier such as polyester or polypropylene. A preferred adhesive utilizes a high peel strength of greater than 30 ounces/inch as measured by PSTC #1 (FTM1), low outgassing of less than 0.1%

collected volatile condensable material (cvcm) as measured by ASTM E-595-84 and E-595-77, solvent-free non-particulating permanent acrylic pressure sensitive adhesive. A commercially available adhesive satisfying these requirements is Bostik P/N 11-610-5. Other adhesives are also suitable such as high temperature permanent acrylic pressure sensitive adhesives, FDA approved adhesives, and removable adhesives.

The adsorbent may comprise one or more layers of 100% adsorbent material such as granular activated carbon or may be a filled product such as a scaffold of porous polymeric material in which void spaces are filled with an adsorbent. Other possibilities include adsorbent impregnated non-wovens such as cellulose or polymeric non-wovens that may include latex or other binders as well as porous castings of adsorbents and fillers that are polymeric or ceramic. The adsorbent may be 100% of a particular adsorbent or may be a mixture of different types of adsorbents, the selection of which is dependent on the specific application. A preferred embodiment is the use of expanded porous polytetrafluoroethylene (PTFE) made in accordance with the teachings in U.S. Patent No. 3,953,566 and 4,187,390, the expanded porous PTFE then filled with a particular adsorbent material. The filled PTFE is particularly desirable because the adsorbent material does not migrate to the outside and cause contamination problems. A layer of filled PTFE is also desirable because it can be made in extremely thin dimensions such as having a thickness of less than about 0.001 inch thus being adaptable to fit in extremely low profile applications.

The adsorbent material may include physisorbents, such as silica gel, activated carbon, activated alumina, or molecular sieve, or chemisorbents, such as potassium permanganate, calcium carbonate, calcium sulfate, powdered metals or other reactants for scavenging gas phase contaminants depending on the known contaminants desired to be removed. In addition, the adsorbent material may be a mixture of the above-mentioned materials. Further, multiple layers of adsorbent materials may be used such that each layer contains a different adsorbent and contaminants may be selectively removed as they pass through the different layers.

**SUBSTITUTE SHEET**

The outer filter layer may comprise any gas permeable, particulate filtration media that allows vapor contaminants to diffuse through it to the adsorbent layer. The outer filter layer also provides a means of containing the adsorbent material (or layer) within the assembly. The filter layer may include polymeric membranes, non-shedding filter paper or laminated filtering materials. A preferred material having a high vapor transmission and high particulate retention is a membrane of expanded porous PTFE, or a laminate thereof.

The most preferred filtering layer is expanded porous PTFE having an air permeability of 7.0 cubic feet/square foot of membrane at a 0.5 inch of water column differential pressure with a particulate filtration efficiency greater than 99.97% retention of particles greater than or equal to 0.3 micrometers in diameter.

The invention is best understood by reference to drawings 2-6. Figure 2 provides an enlarged top view of the filter assembly. In this embodiment, as best seen in cross-section shown in Figure 2a, the filter assembly 1 comprises one layer of an adhesive 10 for attachment of the assembly to an interior surface in the enclosure, an adsorbent material layer 11 and a top filtering layer 12 such that the adsorbent layer 11 is totally encapsulated between the adhesive layer 10 and the filtering layer 12.

Figures 3 and 3a show a second embodiment of the assembly wherein two adhesive layers 10 and 10a in laminar relationship are provided in this embodiment, the second tier of the assembly comprises exterior areas of an adhesive layer 10a and centered between them is disposed the adsorbent layer 11.

Figures 4 and 4a show a third embodiment wherein two adsorbent layers 11 and 11a are employed superimposed on each other (in series) which are further sandwiched between an adhesive layer 10 and an outer filter layer 12.

Figures 5 and 5a show an embodiment of the filter assembly wherein the adsorbent layers 11 and 11a are located in the middle layer in a side-by-side configuration (in parallel) each adsorbent layer surrounded by an adhesive layer 10a. A central adhesive layer further separates the two adsorbent layers. Each adsorbent layer can be of a different size.



Figures 6 and 6a show a fifth embodiment that is similar to the side-by-side configuration shown in Figure 5; however, this embodiment provides for a space between two regions comprising adhesive layers surrounding an adsorbent layer.

A self-adhesive adsorbent filter assembly was made having the following features. The assembly was disk shaped and has a 1.0 inch outside diameter and a thickness of 0.035 inches. A top retention layer was provided comprising expanded porous PTFE membrane that had a thickness of less than 0.001 inches and laminated to a non-woven polyester backing having a thickness of 0.0055 inches. The laminate was at least 99.97% efficient at filtering particulate having a diameter equal to or greater than 0.3 micrometer. The laminate also had a maximum resistance to air flow of 1.38 inches of water at an air velocity of 10.5 fpm.

The adsorbent layer was approximately 0.5 inches in diameter and had a thickness of 0.022 inches. The adsorbent layer was constructed of expanded PTFE filled with activated carbon with a 60% by weight carbon loading and a total carbon content of 0.0257 grams of activated carbon.

The adhesive layer actually comprised two sides of 0.001 inch thick each high temperature permanent acrylic pressure sensitive adhesive on both sides of a polyester film carrier having a thickness of 0.002 inches.

The adsorbent filters were placed on a release liner for easy handling. The adsorbent filter was placed inside a computer disk drive. The assembly was capable of adsorbing over 25 milligrams of gaseous contaminants. When this assembly is placed inside the enclosure housing sensitive equipment such as a computer hard disk drive, it is capable of offering long term protection by preventing gaseous contaminants from reaching the magnetic storage disks and extending the useful life of the drive.

It will be apparent to those skilled in the art that various modifications and variations can be made without departing from the scope of this invention.

WHAT IS CLAIMED IS:

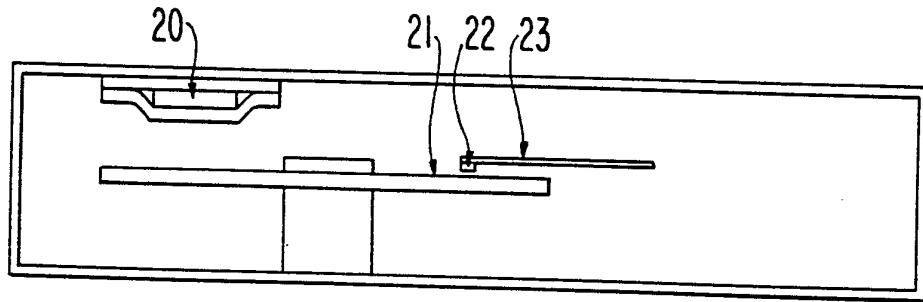
1. An adsorbent assembly having a low profile container for removing gaseous contaminants from an enclosure comprising one or more layers of an adhesive; at least one layer of an adsorbent material, and a layer of filtering material wherein the adsorbent layer is placed between said adhesive layer and filtering layer and wherein said adhesive layer is adhered to a surface inside the enclosure.
2. An adsorbent assembly of Claim 1 wherein the adhesive layer is a double-sided adhesive of non-particulating permanent acrylic coated onto a carrier.
3. An adsorbent assembly of Claim 1 wherein the adsorbent layer comprises a plurality of layers.
4. An adsorbent assembly of Claim 1 wherein the adsorbent layer comprises 100% adsorbent material.
5. An adsorbent assembly of Claim 1 or 3 wherein each adsorbent layer comprises a scaffold of porous polymeric material filled with an adsorbent.
6. An adsorbent assembly of Claim 5 wherein the scaffold of porous polymeric material is expanded porous PTFE.
7. An adsorbent assembly of Claim 6 wherein the thickness of the adsorbent layer is less than about 0.001 inches.
8. An adsorbent assembly of Claim, 1, 3, 4, or 5 wherein the adsorbent material is selected from the group consisting of physisorbents such as silica gel, activated carbon, activated alumina, a molecular sieve.
9. An adsorbent assembly of Claim 1, 3, 4, or 5 wherein the adsorbent material is selected from the group consisting of potassium permanganate, calcium carbonate, calcium sulfate and powdered metals.
10. An adsorbent assembly of Claim 1 wherein the layer of filtering material is selected from the group consisting of polymeric membranes, non-shedding filter paper, laminated filtering materials, non-wovens, spun bonded, and electret materials.
11. An adsorbent assembly of Claim 1 wherein the layer of filtering material is expanded porous PTFE membrane.

**SUBSTITUTE SHEET**

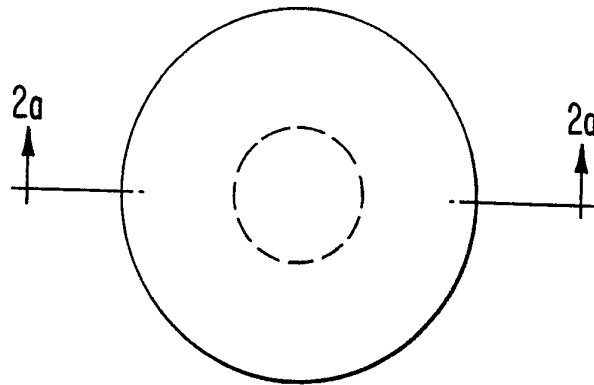
12. An adsorbent assembly of Claim 1 wherein the layer of filtering material is a laminate of expanded porous PTFE and support material.
13. An adsorbent assembly of Claim 11 wherein the porous PTFE has an air permeability of 7.0 cubic feet/square foot of membrane at a 0.5 inches of water column differential pressure and has a filtration efficiency of greater than 99.97% retention of particles greater than or equal to 0.3 micrometers.
14. An adsorbent assembly of Claim 3 wherein the adsorbent layers are superimposed on each other in series.
15. An adsorbent assembly of Claim 3 wherein the adsorbent layers are located in a side-by-side parallel configuration.
16. An adsorbent assembly of Claim 14 or 15 wherein an adhesive layer is disposed between said adsorbent layers.
17. A self-adhesive adsorbent assembly for removing gaseous contaminants from a computer disk drive enclosure comprising: a top filtering layer of expanded porous PTFE laminated to a non-woven backing, a middle adsorbent layer comprising expanded PTFE filled with activated carbon and/or silica gel, and a bottom adhesive layer of a polyester film carrier laminated on two sides with a high temperature permanent acrylic pressure sensitive adhesive wherein the top filtering layer and bottom adhesive layer surround the middle adsorbent layer and further wherein the top filtering layer and bottom adhesive layer meet to form a seam along a peripheral edge of the adhesive layer.
18. A self-adhesive adsorbent assembly of Claim 17 wherein the assembly is disk shaped and has a thickness of about 0.035 inches.
19. A system to protect contaminant sensitive devices comprising a sealed enclosure, a sensitive device, and an adsorbent assembly attached to an inside surface of the sealed enclosure, said assembly comprising one or more layers of an adhesive; at least one layer of an adsorbent material, and a layer of filtering material.
20. A system to protect contaminant sensitive devices as described in Claim 19 wherein said sealed enclosure has a filtered vent hole.

**SUBSTITUTE SHEET**

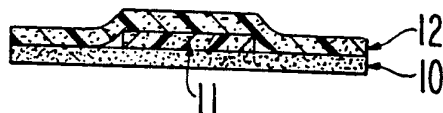
**FIG. 1**



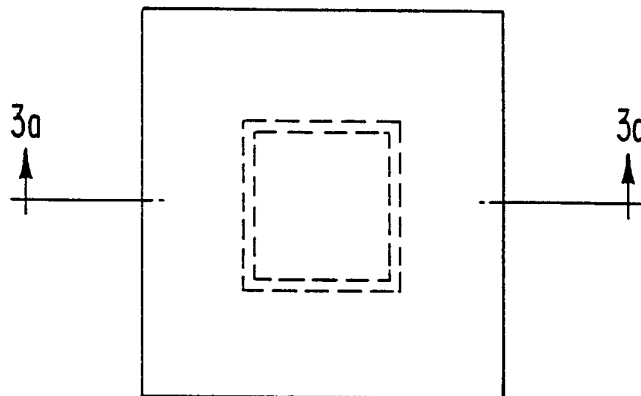
**FIG. 2**



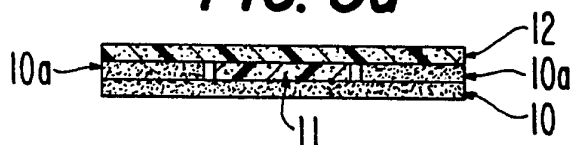
**FIG. 2a**



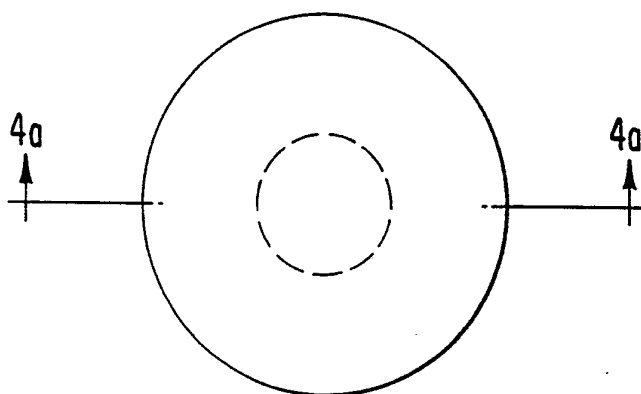
**FIG. 3**



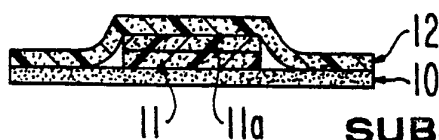
**FIG. 3a**



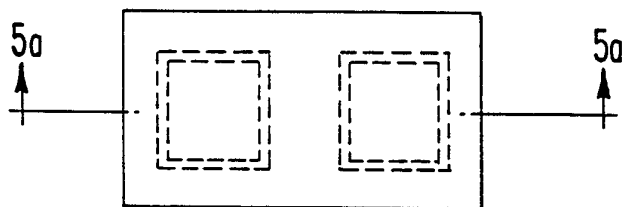
**FIG. 4**



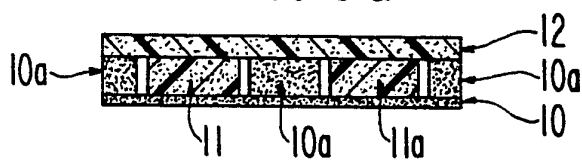
**FIG. 4a**



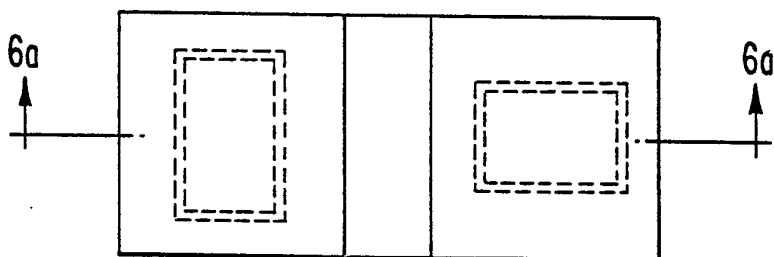
**FIG. 5**



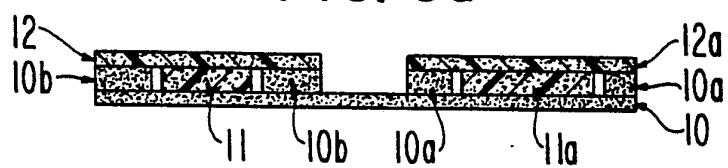
**FIG. 5a**



**FIG. 6**

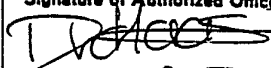


**FIG. 6a**



# INTERNATIONAL SEARCH REPORT

International Application No PCT/US 91/01876

<b>I. CLASSIFICATION OF SUBJECT MATTER</b> (if several classification symbols apply, indicate all) <sup>6</sup>		
According to International Patent Classification (IPC) or to both National Classification and IPC		
IPC <sup>5</sup> : B 01 D 53/04		
<b>II. FIELDS SEARCHED</b>		
Minimum Documentation Searched <sup>7</sup>		
Classification System	Classification Symbols	
IPC <sup>5</sup>	B 01 D, B 01 J	
Documentation Searched other than Minimum Documentation to the Extent that such Documents are Included in the Fields Searched <sup>8</sup>		
<b>III. DOCUMENTS CONSIDERED TO BE RELEVANT <sup>9</sup></b>		
Category <sup>10</sup>	Citation of Document, <sup>11</sup> with indication, where appropriate, of the relevant passages <sup>12</sup>	Relevant to Claim No. <sup>13</sup>
A	EP, A, 0225593 (KAKEN PHARMACEUTICAL CO. LTD.) 16th June 1987 see claims 1-3; column 1, lines 11-16; figure 6	1, 4, 8, 10, 15
A	----- US, A, 4830643 (ROBERT L. SASSA) 16th May 1989 see claims 1-11 cited in the application -----	1, 4, 6, 8-12, 15, 17
<p><sup>10</sup> Special categories of cited documents: <sup>10</sup></p> <p>"A" document defining the general state of the art which is not considered to be of particular relevance</p> <p>"E" earlier document but published on or after the international filing date</p> <p>"L" document which may throw doubts on priority claim(s) or which is cited to establish the publication date of another citation or other special reason (as specified)</p> <p>"O" document referring to an oral disclosure, use, exhibition or other means</p> <p>"P" document published prior to the international filing date but later than the priority date claimed</p> <p>"T" later document published after the international filing date or priority date and not in conflict with the application but cited to understand the principle or theory underlying the invention</p> <p>"X" document of particular relevance; the claimed invention cannot be considered novel or cannot be considered to involve an inventive step</p> <p>"Y" document of particular relevance; the claimed invention cannot be considered to involve an inventive step when the document is combined with one or more other such documents, such combination being obvious to a person skilled in the art.</p> <p>"&amp;" document member of the same patent family</p>		
<b>IV. CERTIFICATION</b>		
Date of the Actual Completion of the International Search	Date of Mailing of this International Search Report	
10th July 1991	02. 09. 91	
International Searching Authority	Signature of Authorized Officer	
EUROPEAN PATENT OFFICE	 Danielle van der Haas	

**ANNEX TO THE INTERNATIONAL SEARCH REPORT  
ON INTERNATIONAL PATENT APPLICATION NO.**

US 9101876  
SA 46381

This annex lists the patent family members relating to the patent documents cited in the above-mentioned international search report. The members are as contained in the European Patent Office EDP file on 27/08/91. The European Patent Office is in no way liable for these particulars which are merely given for the purpose of information.

Patent document cited in search report	Publication date	Patent family member(s)	Publication date
EP-A- 0225593	16-06-87	JP-A- 62135168 US-A- 4749392	18-06-87 07-06-88
US-A- 4830643	16-05-89	AU-A- 3970589 EP-A- 0428558 WO-A- 9000438	05-02-90 29-05-91 25-01-90