

S. Nicolson. Sheet 1, 2, Sheets.

Ice Boat & Breaker.

No. 3,668.

Patented Jul. 16, 1844.

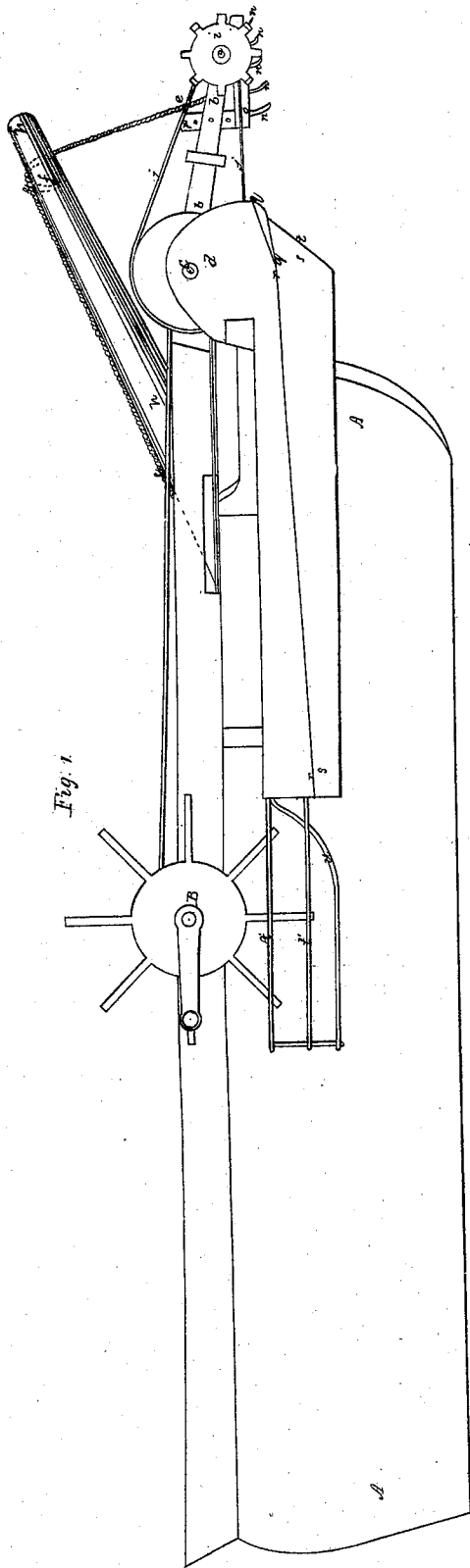

Fig. 1

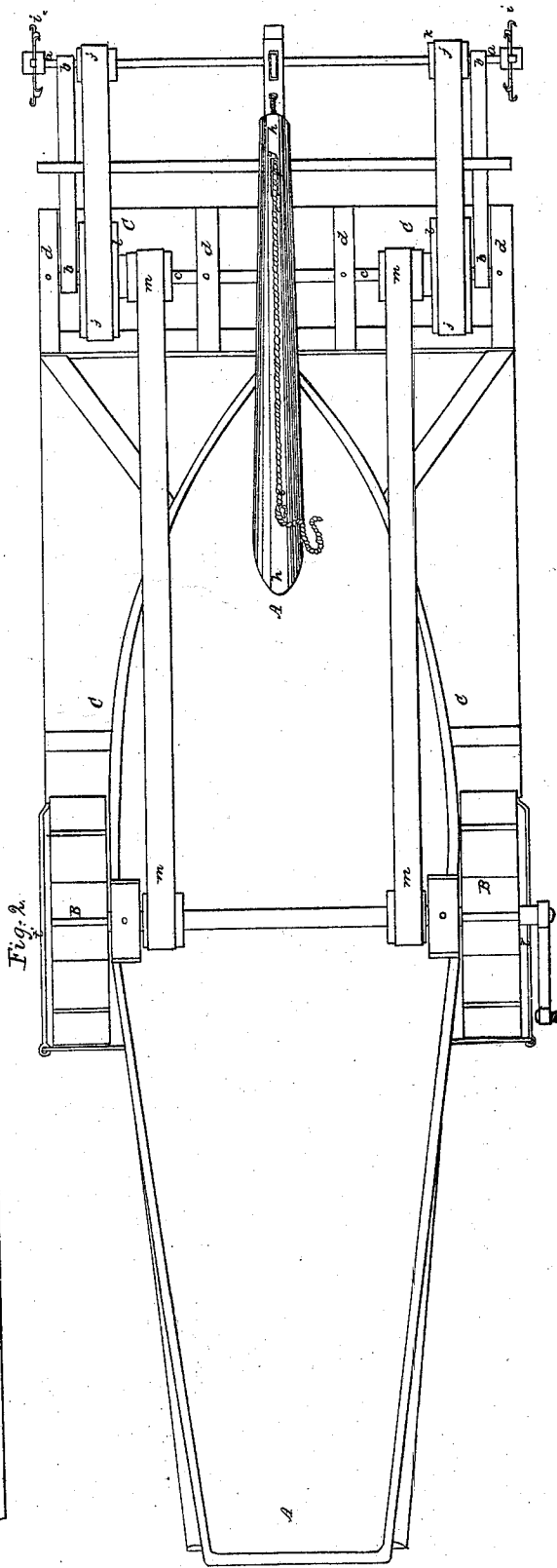

Fig. 2



# UNITED STATES PATENT OFFICE.

SAMUEL NICOLSON, OF BOSTON, MASSACHUSETTS.

## ICE-BREAKER FOR BOATS AND OTHER VESSELS.

Specification of Letters Patent No. 3,668, dated July 16, 1844.

*To all whom it may concern:*

Be it known that I, SAMUEL NICOLSON, of Boston, in the county of Suffolk and State of Massachusetts, have invented new and useful Improvements in Machinery for Breaking Up and Displacing or Removing Ice Which Forms in Rivers, Harbors, &c., and that the following description, taken in connection with the accompanying drawings hereinafter referred to, forms a full and exact specification of the same, wherein I have set forth the nature and principles of my said improvements by which my invention may be distinguished from others for a similar purpose, together with such parts or combinations as I claim and desire to have secured to me by Letters Patent.

The machines or apparatus, which have heretofore been devised for the above specified purpose, have failed in accomplishing effectually the desired result, by reason of the absence or want of some adequate means for displacing or clearing away the pieces or cakes of ice, which have been separated from the main body of the same.

My improvements combine mechanical arrangements for cutting the ice into strips; for breaking said strips into blocks or smaller pieces, and depressing and passing or guiding the same under the main body of ice, on each side of the steam tow or tug boat, (to the bow of which my improvements are to be attached); and also for protecting the propelling wheels of the boat from the destructive effects which would result from their coming in contact with drift ice and other floating substances. The first of the above results is effected, by means of circular cutters or straight plows, arranged some little distance in front of the bow of the boat, so as to be propelled along with it, the circular cutters being driven by bands from any proper shaft of the steam engine. The breaking, depressing and removing the ice is provided by a "shield" or "shoe," attached to the bow of the boat but in rear of the cutters aforesaid, said shield or shoe being as wide as the combined width of the boat and paddle wheels, and having its underside formed with such planes as will depress and guide the ice as herein above specified. The protection to the paddle wheels is secured by the arrangement of guards, composed of rods or thin strips or bars of iron, about the lower parts of the wheels, the rods being fixed at such intervals apart as

to exclude ice &c. but to allow the free flowing of the water.

The figures of the accompanying plate of drawings represent my improvements.

Figure 1, is a side elevation of a boat with my improvement attached to the bow of the same. Fig. 2, is a top view or plan of the same, and Fig. 3, is a plan or view of the underside of the same showing the planes of the shoe &c.

*a a* Figs. 1, 2, 3, is a long shaft equal in length to the width of the track to be cut, or to the combined width of the boat *A, A*, and the paddle wheels *B, B*. This shaft has proper bearings in which it revolves in the timber framework *b b b b*, which may be constructed of longitudinal and transverse beams properly framed together, as seen in the drawings, Figs. 2, and 3, or in any other suitably strong manner. This framework *b b b b*, is arranged so as to be raised and lowered by turning (on its rear side or that nearest to the bow of the boat), on a long shaft *c c* Figs. 1, 2, which shaft has suitable bearings in the upright blocks *d, d, d, d*, supported on the shield or shoe *c c c c* which will be explained hereinafter; the raising and lowering is accomplished by means of a cord *e e e* Figs. 1, and 2, connected to said framework, and passing over a pulley *f*, properly supported, so as to turn, in a mortise *g* of an inclined mast or bowsprit *h h* firmly secured to some convenient part of the front of the boat.

Circular revolving cutters *i i*, Figs. 1, 2, 3, may be placed and firmly fastened on the shaft *a a*, at any proper intervals apart, for the purpose of cutting the ice into strips. The cutters of a circular kind which I have devised and think preferable to all kinds of circular saws have their teeth formed in a hooked shape as shown in Figs. 2, and 3, the turn or bend of the teeth being curved or angular, as may seem most fitting, and said bend or turn being alternately on one and the opposite side of the cutter, or so that each tooth shall be bent in an opposite direction to that of the one which precedes it, which arrangement it will be seen provides for the cutting of wide grooves in the ice. The revolutions of the circular cutters are effected by bands or chain belts *j j j j* passing from pulleys *k, k*, on the shaft *a a*, to other pulleys *l, l*, on the shaft *c c*, which latter shaft is revolved by similar bands or belts *m m, m m* passing from it to any

proper shaft of the steam engine or of whatever motive power may be used. In view of the circular cutters above described any of the various kinds of ice plows may be used, being arranged along the front of the framework *b b b b*.

The plow which I have designed is represented partially in Fig. 1, and more particularly in Figs. 4, and 5, which are detailed views, the former being a side and the latter a front view of the same.

The several teeth *n n* &c. are secured to the beam *o*, each tooth being longer than that which precedes it, and being of a bow shape, so as to have a cutting edge all around the bow as seen in Fig. 5, and an open space in the middle to allow the chips of ice to pass through. The rear end of the beam *o* of the plow may be raised and lowered by the vertical adjustment provided for in the upright bar *p* which will be seen by inspection of Fig. 4, which adjustment accommodates the machinery to ice of different thickness.

The above description embraces all that part of the machinery which has for its object the cutting of the ice. The next process is to break it into pieces and clear it away. This is done by the shoe or shield *c c c c* herein above mentioned. This shoe is constructed of timber or plank strongly framed and is formed so as to fit the bow of the boat to which it is to be very firmly fastened by bolts and braces or otherwise. The total width of the shield is like the length of the shaft *a a* equal to the combined width of the boat and paddle wheels, so that the faces of the sides of the shield shall be in the same vertical planes with the exterior sides of the wheel the length of said shield extending to about "midships." The underside of this shield is formed as follows: Across the front of the same there is a short incipient inclined plane *q q q q* Figs. 1, and 3, the object of which is to enable or cause the shield to rise upon the strips of ice after they have been sawed, said plane being made sufficiently abrupt for this purpose. From the rear line of this plane commence two triangular and more gradually inclined planes *r r r r*, *r r r r* which extend to the rear of the shield on each side of the bow of the boat as shown in Fig. 3, their apexes being in the same plane with the respective sides of the shield. Two diverging vertical planes *s s*, *s s* starting from a common line to near the center point of the front line of the plane *q q q q*, said line *t* being in the same longitudinal vertical plane as the an-

gles of the bow of the boat, form a wedge which should enter into the center groove made by the plows or cutters; these two vertical planes diverge until their rear ends would meet, vertical planes drawn by or tangents to the sides of the shield. The difference of level between the front of the plane *q q q q*, and the rear ends or apexes of the triangular planes *r r r*, *r r r*, should be sufficient to depress the pieces of ice to a depth equal to the thickness of any ice, and it will readily be seen that the above specified arrangement of the vertical planes *s s*, *s s* will serve to guide or pass the pieces so depressed, under the main body of the ice as herein above set forth. This shield may be permanently fastened to the boat or it may be arranged so as to be removed from or adapted to the same at pleasure, and the various planes may be protected with iron; it will also be evident that modifications may be made in the arrangement of the planes on the underside of the shield, but the essential principles must remain the same and must involve the power to break, depress, and pass away the pieces of ice.

The guards about the paddle wheels to protect the floats of the same and prevent blocks of drift ice or other floating substances from coming in contact with them, are composed of the longitudinal side bars *t'*, *t'*, Figs. 1, 2, 3, arranged on the outside of the wheel and returned and fastened to the sides of the vessel (see Figs. 2, 3,) and of the curved bars *u*, *u*, *u*, arranged on the underside of the wheel as seen in the drawings or in any other proper manner.

Having thus set forth and described my improvements I shall specify my claim as follows:

What I claim as my invention and desire to secure by Letters Patent is—

Making the shield or shoe at the bow to consist of a combination of inclined surfaces, arranged as herein described, so as to depress and carry the ice under, and on each side, the shield being as wide or nearly so, as the extreme width across the paddle wheels by which the boat is propelled.

In testimony that the foregoing is a true description of my said invention and improvements I have hereto set my signature this thirteenth day of March, in the year eighteen hundred and forty-four.

SAMUEL NICOLSON.

Witnesses:

EZRA LINCOLN, Jr.,  
JAS. B. ROBB.