

(No Model.)

2 Sheets—Sheet 1.

W. S. VARNER.
MIDLINGS PURIFIER.

No. 250,856.

Patented Dec. 13, 1881.

Fig. 1.

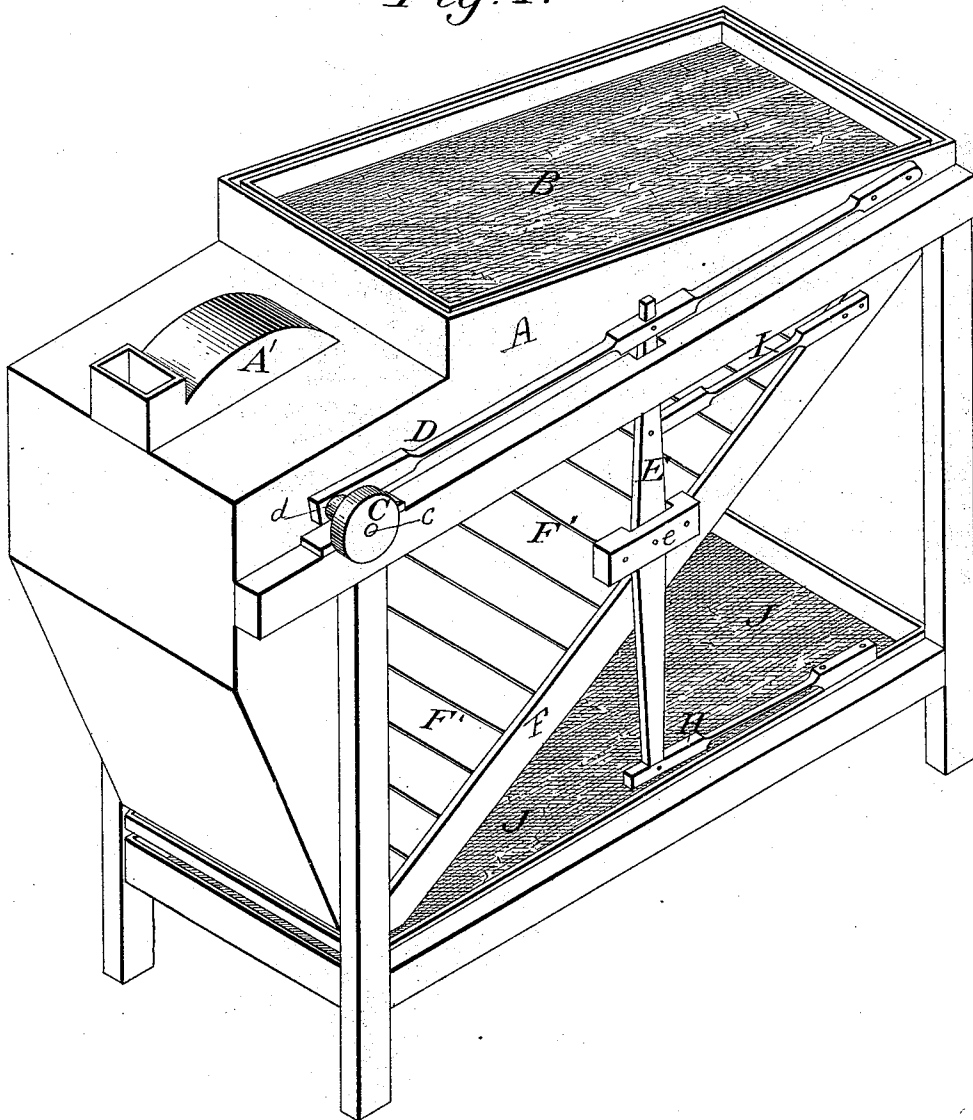

Witnesses:
Geo. Phillips
W. S. Mather

Inventor:
W. S. Varner
Per
W. Alexander

(No Model.)

2 Sheets—Sheet 2.

W. S. VARNER.
MIDLINGS PURIFIER.

No. 250,856.

Patented Dec. 13, 1881.

Fig. 2.

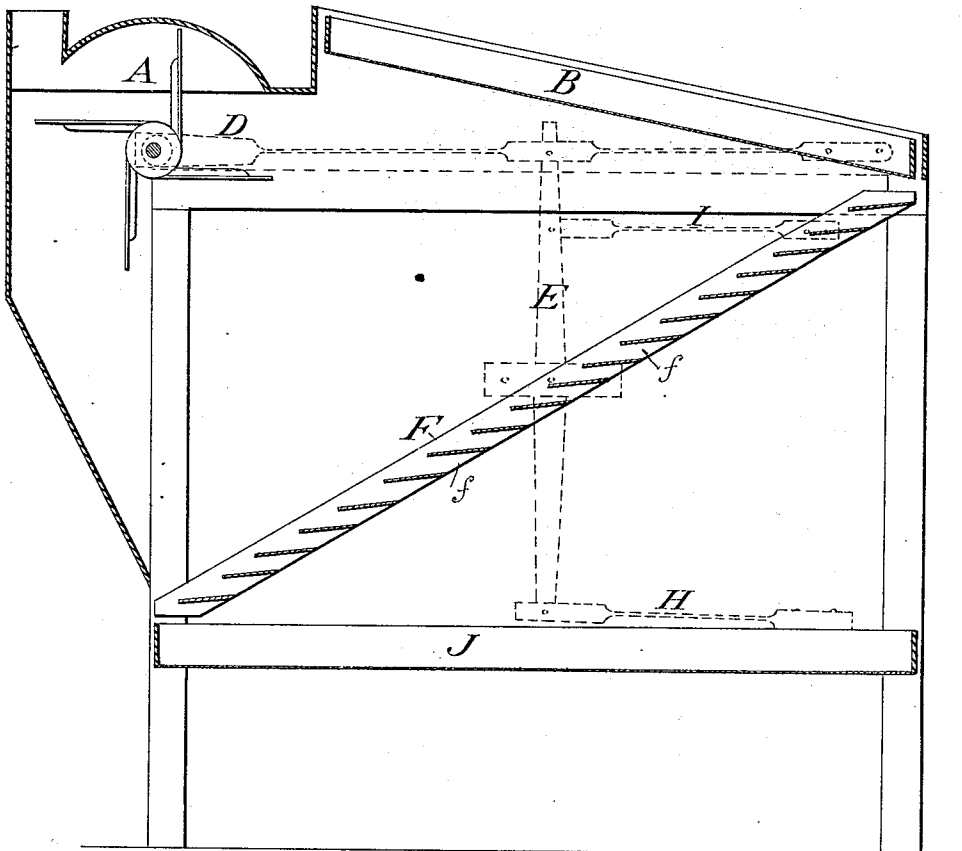

Witnesses:
Jno. Phillips
W. S. Walker

Inventor:
W. S. Varner
Per
W. Alexander

UNITED STATES PATENT OFFICE.

WILLIAM S. VARNER, OF ALEXANDRIA, PENNSYLVANIA.

MIDLINGS-PURIFIER.

SPECIFICATION forming part of Letters Patent No. 250,856, dated December 13, 1881.

Application filed April 29, 1881. (No model.)

To all whom it may concern :

Be it known that I, WILLIAM S. VARNER, a citizen of the United States, residing at Alexandria, in the county of Huntingdon, State of Pennsylvania, have invented a new and useful Improvement in Middlings-Purifiers, which improvement is fully set forth in the following specification.

This invention relates to certain improvements in middlings-purifiers; and it has for its objects to separate the light and imperfect matter from the middlings by an exhaust-current of air while the middlings are passing from an upper to a lower screen, whereby the clogging of the bolting-cloth of the screen is prevented, as more fully hereinafter specified. These objects I attain by the apparatus illustrated in the accompanying drawings, in which—

Figure 1 represents a perspective view of my improved apparatus, with part of casing removed to show interior; and Fig. 2, a vertical sectional view of the same.

The letter A indicates the main casing and frame of the apparatus, and A' an exhaust-fan located at the front of the upper part of said frame.

The letter B indicates an inclined reciprocating bolting-screen, located at the top of the frame A, and supported therein in any convenient manner.

To the frame, at one side, is attached one end of a spring-bar, D, the other end of which is secured to an eccentric, *d*, on the fan-shaft *e*, in such manner as to impart a reciprocating motion to the screen as the shaft is rotated.

C indicates a driving-pulley, secured to the said shaft.

The letter F indicates a rectangular reciprocating frame, inclining from the top at the rear of the main frame to the bottom at the front of the same. The said frame F is provided with a series of slightly-inclined slats, F', ar-

ranged to leave suitable intervening spaces, *f*, between them for the passage of air.

I indicates a spring-bar connecting the frame F with the lever E, which connects with the bar D, and is fulcrumed at *e* to the frame or casing. The lower end of the lever E connects with one end of a spring-bar, H, the other end of which is connected to the lower reciprocating screen, J.

The operation of my improved apparatus will be readily understood in connection with the foregoing description. The driving-pulley C, being put in motion by means of a suitable band, imparts a rotary motion to the fan-shaft and a reciprocating motion through the medium of the connections D E I H to the screens B J and frame F. The middlings are placed in the upper screen and pass down over the slats F', where they are subjected to the exhaust-air current established by the fan, by means of which the lighter particles and impurities are separated. They then pass on to the screen J, where the final separation is effected.

Having thus described my invention, what I claim, and desire to secure by Letters Patent, is—

1. The combination of the fan A', screen B, spring D, eccentric *d*, lever E, spring-bar I, and slatted frame F, all arranged to operate substantially in the manner specified.

2. The combination, in a middlings-purifier, of the fan A', inclined slatted frame F', screens B J, spring D, eccentric *e*, lever E, and spring-bars I H, all constructed and arranged to operate substantially as and for the purpose set forth.

WILLIAM S. VARNER.

Witnesses:

H. N. CRESSWELL,
W. S. WALKER.