



(12) **EUROPEAN PATENT APPLICATION**

(43) Date of publication:  
**11.10.2006 Bulletin 2006/41**

(51) Int Cl.:  
**F21S 8/00<sup>(2006.01)</sup> F21V 21/10<sup>(2006.01)</sup>**

(21) Application number: **06111443.5**

(22) Date of filing: **21.03.2006**

(84) Designated Contracting States:  
**AT BE BG CH CY CZ DE DK EE ES FI FR GB GR  
HU IE IS IT LI LT LU LV MC NL PL PT RO SE SI  
SK TR**  
Designated Extension States:  
**AL BA HR MK YU**

(71) Applicant: **iGUZZINI ILLUMINAZIONE S.p.A.  
62019 Recanati-Macerata (IT)**

(72) Inventor: **Guzzini, Giannunzio  
62019, Recanati (Macerata) (IT)**

(30) Priority: **08.04.2005 IT MI20050123 U**

(74) Representative: **De Gregori, Antonella et al  
Ing. Barzano' & Zanardo Milano S.p.A.  
Via Borgonuovo 10  
20121 Milano (IT)**

(54) **Unit consisting of a pole for lighting appliances and a relative device for the assembly of at least one lighting body**

(57) A unit consisting of a pole (11) for lighting appliances and a relative device for the assembly (12) of at least one lighting body (13) comprising a tubular element (14) substantially having the same section of the pole (11), in which the tubular element (14) and the pole (11) respectively comprise facing coupling surfaces (16, 17) equipped with complementary constraining means (18) with a vertical axis, the assembly device (12) being openable above by the tightening of the constraining means (18).

**Fig. 5**

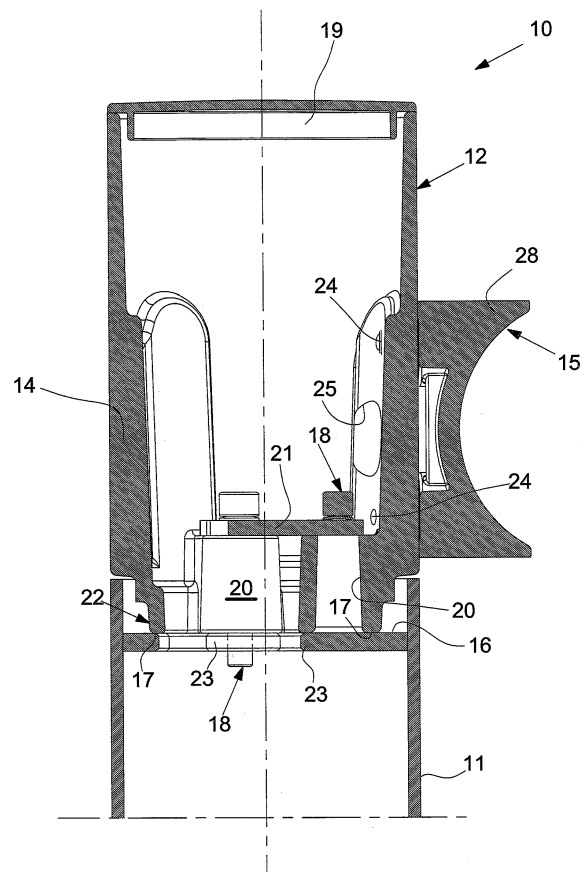

## Description

**[0001]** The present invention relates to a unit consisting of a pole for lighting appliances and a relative device for the assembly of at least one lighting body.

**[0002]** Lighting appliances, in particular, for street lighting or for external environments are generally applied close to an upper end of a pole which, in addition to supporting the lighting appliances, houses and seals electric wires.

**[0003]** An objective of the present invention is to provide a unit consisting of a pole for lighting appliances and a relative device for the assembly of at least one lighting body comprising a reduced number of elements which can be easily assembled.

**[0004]** A further objective of the present invention is to provide a visibly screwless sealed unit.

**[0005]** Another objective of the present invention is to provide a unit consisting of a pole for lighting appliances and a relative device for the assembly of at least one lighting body which is particularly simple and functional, with limited costs.

**[0006]** These objectives according to the present invention are achieved by providing a unit consisting of a pole for lighting appliances and a relative device for the assembly of at least one lighting body as specified in claim 1.

**[0007]** Further characteristics of a unit are object of the dependent claims.

**[0008]** The characteristics and advantages of a unit consisting of a pole for lighting appliances and a relative device for the assembly of at least one lighting body according to the present invention will appear more evident from the following illustrative and non-limiting description, referring to the enclosed drawings in which:

figure 1 is a perspective view of a lighting appliance comprising a pole and a lighting body connected thereto;

figure 2 is a raised view of a unit consisting of a pole for lighting appliances and a relative device for the assembly of a lighting body according to the present invention;

figures 3 to 5 are sectional views of the unit of figure 2 indicated respectively according to the traces III-III, IV-IV and V-V;

figure 6 shows a further embodiment of the invention wherein the device for the assembly allows the assembly of three lighting bodies.

**[0009]** With reference to the figures, these show a unit, indicated as a whole with 10, consisting of a pole 11 for lighting appliances and a relative device for the assembly 12 of one or more lighting bodies 13 on the top of the pole 11.

**[0010]** Figures 1 to 5 show how the device 12, used for the assembly of a lighting body 13, comprises a tubular element 14 substantially having the same section

of the pole 11, which is shown in the figures for illustrative but non-limiting purposes with a circular section.

**[0011]** The lighting body is then connected to the assembly device 12 by means of an articulation, for example with a joint 15, or rigidly.

**[0012]** The tubular element 14 and the pole 11 respectively comprise facing coupling surfaces 16 and 17, equipped with complementary constraining means 18 with a vertical axis, for example of the threaded type. The tubular element 14, which is internally hollow, is applied in a removable manner to the top of the pole 11 by means of the constraining means which are accessible from the inside through an upper opening which can be closed as a sealing by a cover 19.

**[0013]** A first surface 16, arranged close to the top of the pole 11, is equipped with threaded holes, i.e. at least one threaded hole, for coupling with the same number of threaded stems.

**[0014]** The constraining means 18, for example screws, are housed in pass-through seats 20 situated on a second coupling surface 17 positioned close to a lower end of the tubular element 14.

**[0015]** The constraining means 18, which in the embodiment shown are equal to three, are distributed along the perimeter of the complementary coupling surfaces, for example equidistant from each other.

**[0016]** Figures 3 and 5 also show a perforated flange 21 positioned on the upper surface of the pass-through seats 20 for the buffer positioning of the heads of the screws 18.

**[0017]** For a greater centering stability, the first coupling surface 16 is situated at a lower height with respect to the top of the pole 11. The tubular element 14 does in fact have a lower centering portion 22 with a reduced diameter which is inserted into the top of the pole 11 to produce the contact between the coupling surfaces 16 and 17 in the internal area of the pole 11.

**[0018]** The first coupling surface 16, for example a plate welded to an inner surface of the pole, equipped with threaded holes in addition to at least one opening for the passage of wires.

**[0019]** The first coupling surface 16, according to a preferred embodiment shown in the figures, consists of a series of protuberances 23 with a flat upper surface which extend from the inner wall of the pole 11 towards its inside in correspondence with the screws 18, and in which each of the protuberances 23 is equipped with a threaded hole.

**[0020]** The device for the assembly of an illuminating body also comprises an arm 28 extending outwards in a substantially orthogonal direction with respect to the tubular element 14 for the jointed constraint with the illuminating body 13. Said arm 28, however, can extend outwards in any other direction considered suitable.

**[0021]** The arm 28, which can be produced in a single piece with the tubular element 14, or removably joined to the same with screws 24, has a joint 15 at a free end for orientating the lighting body 13, which can be of any type known to experts in the field.

**[0022]** As shown in figures 3 to 5, according to a preferred embodiment, the tubular element 14 and the arm 28 are also equipped with holes 25 for the passage of wires.

**[0023]** Figure 6 shows how the assembly device allows, according to the same innovative concept, three arms 28 to be assembled, arranged at 120° from each other with respect to the axis of the pole 11. In this case, there is either the integral formation of said number of arms or the presence of adequate removable fixing elements (screws 24). The number of arms and their positioning can differ each time in relation to the specific demands.

**[0024]** The application of the single lighting body 13 to the upper end of the pole 11 is effected, after passing the wire, not shown, leaving the pole through the assembly device 12, by resting it on the top of the pole 11 with the coupling surfaces 16 and 17 in contact with each other.

**[0025]** By tightening the screws 18 from inside the tubular element 14 and positioning the lid 19, the assembly device is firmly applied to the top of the pole 11. It is therefore possible to join the lighting body 13 to the arm 28 of the assembly device 12 and terminate its wiring.

**[0026]** The unit consisting of a pole for lighting appliances and a relative device for the assembly of at least one lighting body, object of the present invention, has the advantage of being able to be easily assembled.

**[0027]** The unit advantageously envisages an aligned positioning of the elements thus reducing discontinuity on the outer surface of the product.

**[0028]** Furthermore, in the unit, object of the present invention, the constraining means to the pole are advantageously protected with respect to the outside environment thus reducing possible infiltrations of water and humidity inside the pole itself.

## Claims

1. A unit consisting of a pole (11) for lighting appliances and a relative device for the assembly (12) of at least one lighting body (13), comprising a tubular element (14) substantially having the same section of the pole (11), **characterized in that** said tubular element (14) and said pole (11) respectively comprise facing coupling surfaces (16, 17) equipped with complementary constraining means (18) with a vertical axis, said assembly device (12) being openable above by the tightening of said constraining means (18).
2. The unit according to claim 1, **characterized in that** said constraining means (18) comprise at least one threaded hole on a first of said coupling surfaces (16) situated close to the top of said pole (11), and at least one threaded stem housed in at least one pass-through seat (20) produced on a second of said coupling surfaces (17) situated close to a lower end of said tubular element (14).
3. The unit according to claim 2, **characterized in that** said first coupling surface (16) is situated at a lower height with respect to the top of said pole (11).
4. The unit according to claim 3, **characterized in that** said tubular element (14) comprises at the lower end, a lower centering portion (22) with a reduced diameter for the insertion of said pole (11) into the top.
5. The unit according to claim 2, **characterized in that** said constraining means (18) are distributed along the perimeter of said complementary coupling surfaces (16, 17).
6. The unit according to claim 2, **characterized in that** said device for the assembly (12) of at least one lighting body comprises a perforated flange (21) situated on the upper surface of said pass-through seats (20) for the buffer positioning of the constraining means (18).
7. The unit according to claim 1, **characterized in that** said first coupling surface (16) is a plate joined to an inner surface of said pole, said plate being equipped with at least one opening for the passage of wires.
8. The unit according to claim 7, **characterized in that** said first coupling surface (16) consists of a series of protuberances (23) which extend from the internal wall of the pole (11), each of said protuberances (23) having constraining means (18).
9. The unit according to claim 1, **characterized in that** said tubular element (14) can be closed above as a seal by means of a cover (19).
10. The unit according to claim 1, **characterized in that** said assembly device (12) comprises at least one arm (28) for constraint to the lighting body (13) extending outwards with respect to said tubular element (14).
11. The unit according to claim 10, **characterized in that** said at least one arm (28) extends outwards in a substantially orthogonal direction.
12. The unit according to claim 10 or 11, **characterized in that** said at least one arm (28) is removably joined by means of screws (24) to said tubular element (14).
13. The unit according to claim 10 or 11, **characterized in that** said at least one arm (28) comprises at a free end a joint (15) for the orientation of said lighting body (13).
14. The unit according to claim 10 or 11, **characterized**

**in that** said tubular element (14) and said at least one arm (28) are equipped with holes (25) for the passage of wires.

5

10

15

20

25

30

35

40

45

50

55

4

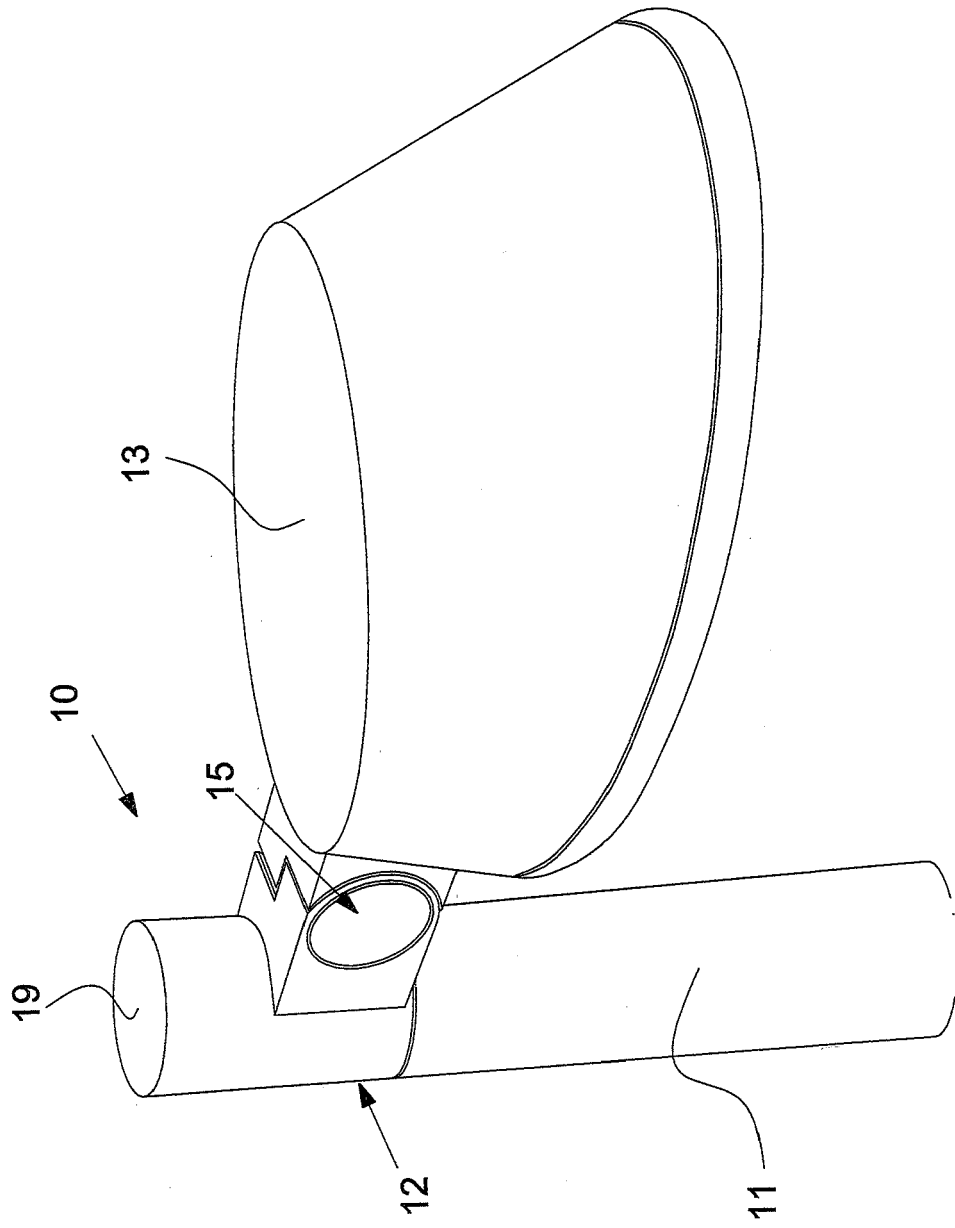

Fig. 1

Fig. 2

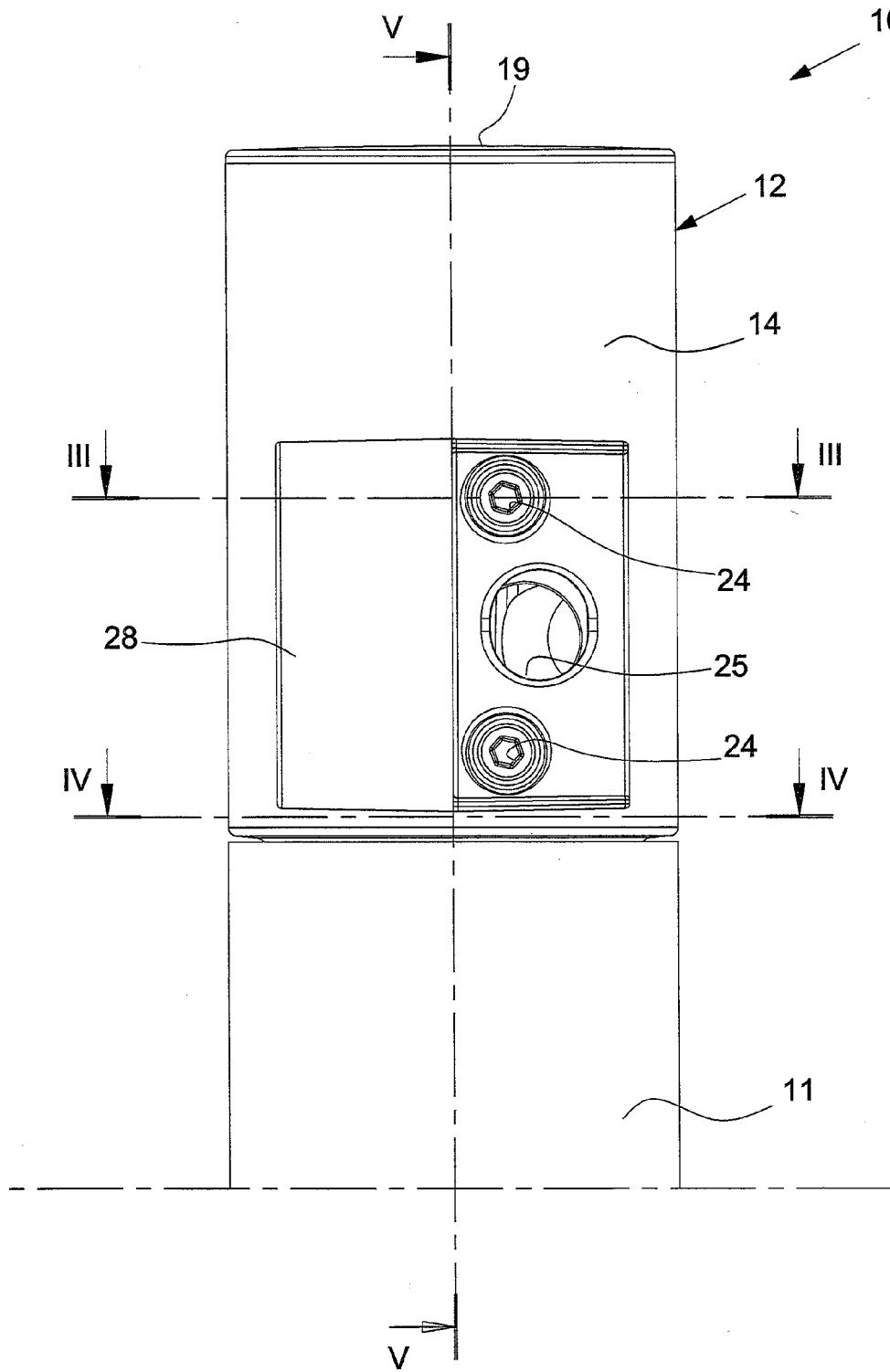

Fig. 3

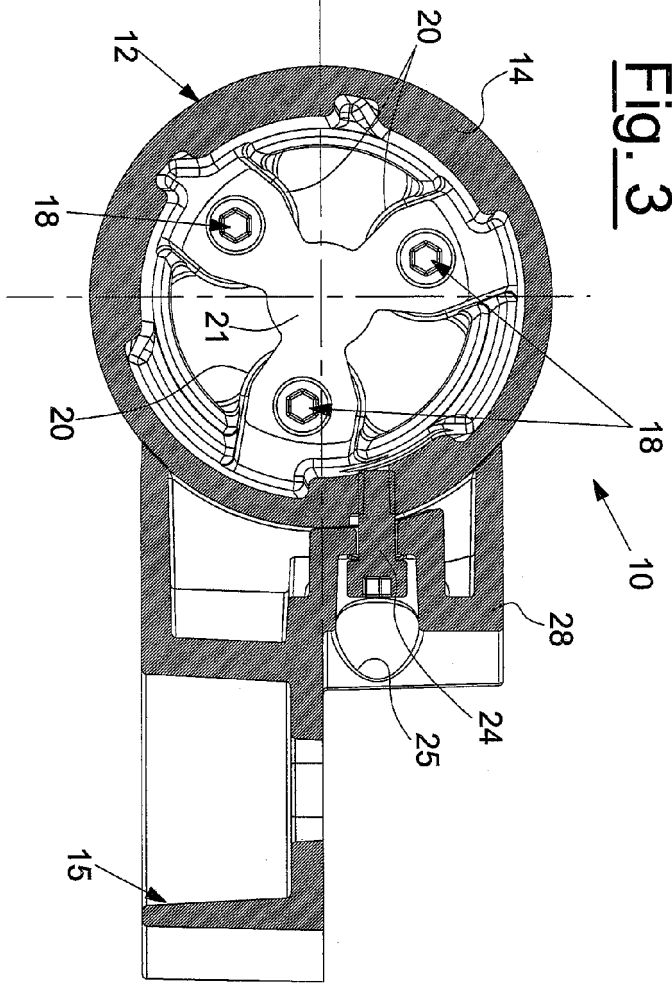

Fig. 4

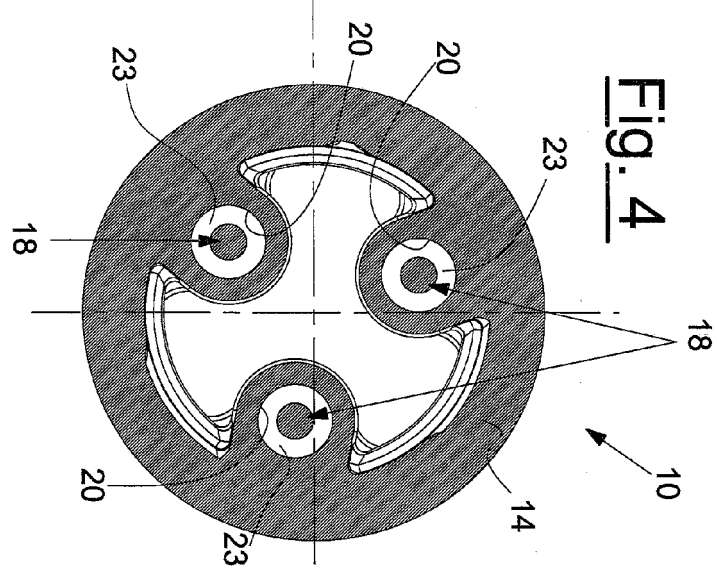

Fig. 5

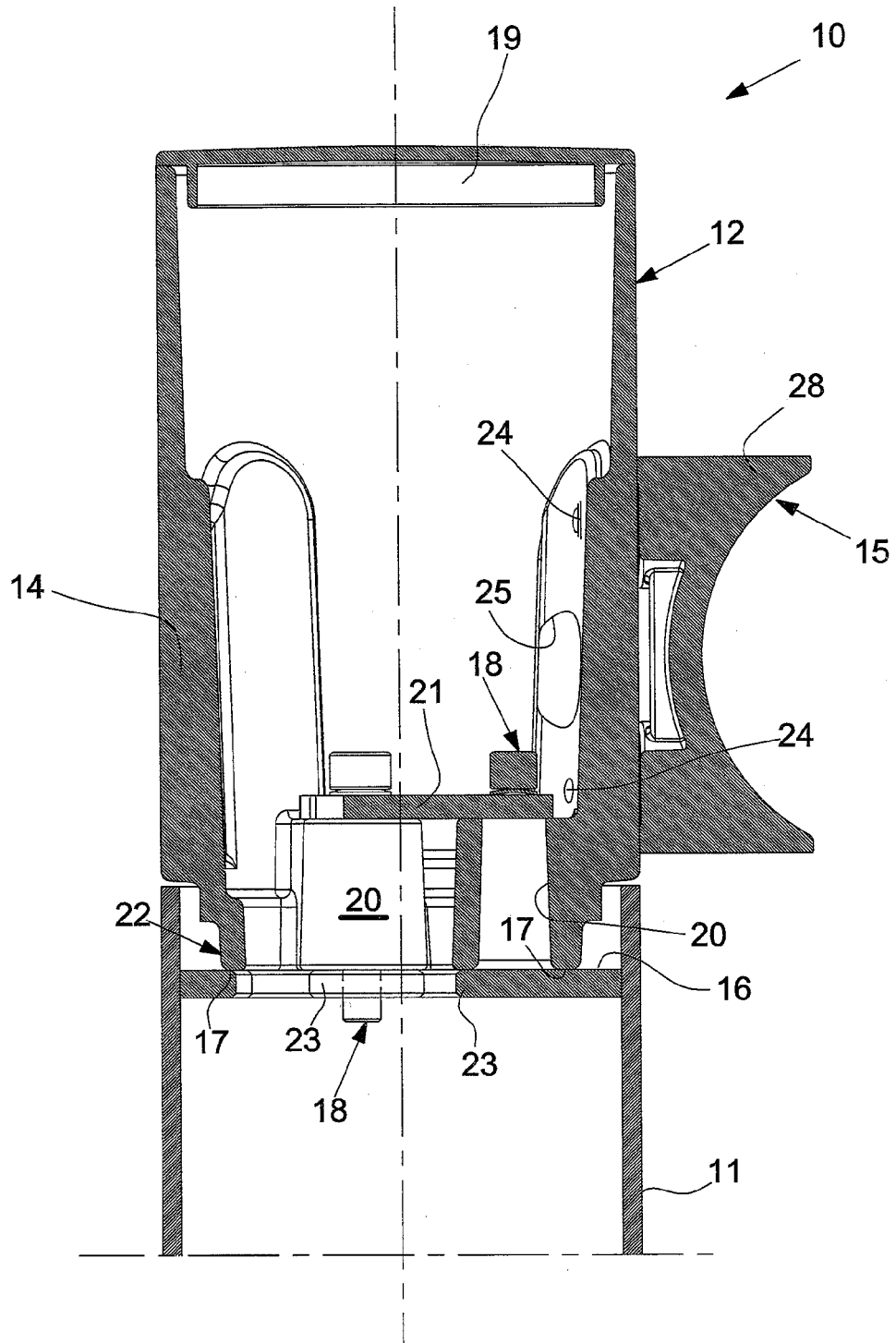

Fig. 6

