

D. G. WILLIAMS.
MUFFLER FOR GAS ENGINES.
APPLICATION FILED OCT. 31, 1904.

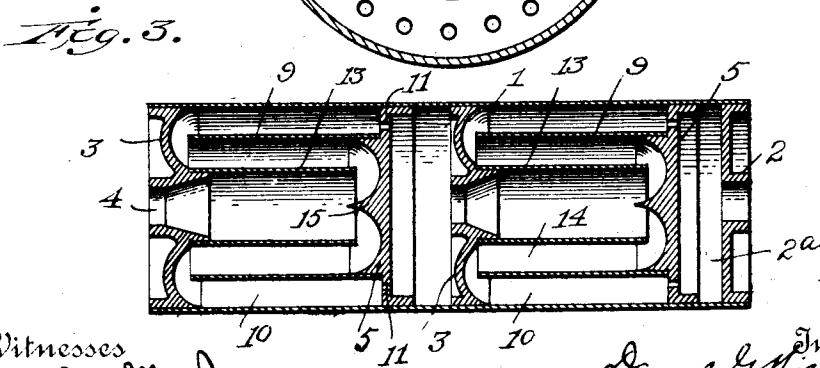
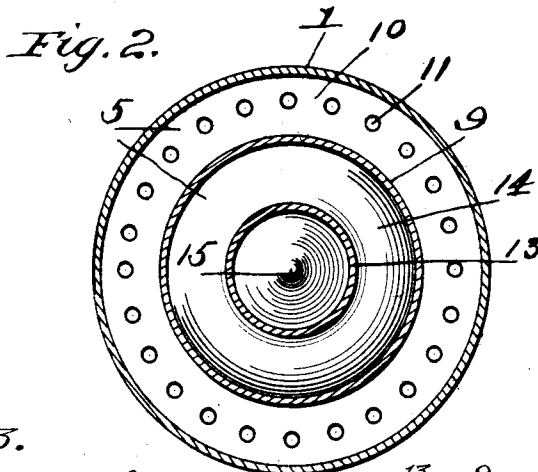
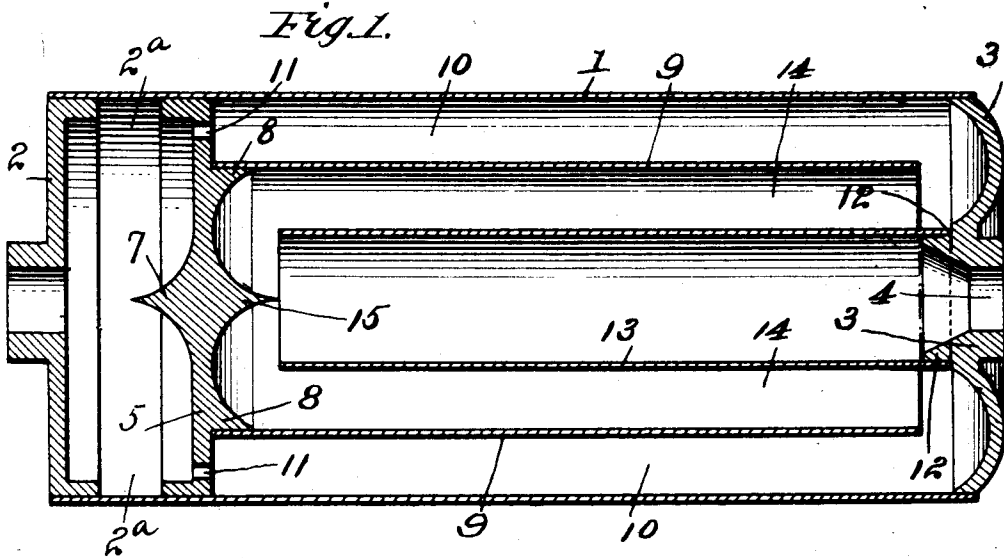

Witnesses
James M. Allen Jr.
Walter Yates

Inventor
Daniel G. Williams
By his Attorneys
Davis & Davis

UNITED STATES PATENT OFFICE.

DANIEL G. WILLIAMS, OF CHARLEVOIX, MICHIGAN.

MUFFLER FOR GAS-ENGINES.

SPECIFICATION forming part of Letters Patent No. 792,804, dated June 20, 1905.

Application filed October 31, 1904. Serial No. 231,032.

To all whom it may concern:

Be it known that I, DANIEL G. WILLIAMS, a citizen of the United States of America, residing at Charlevoix, in the county of Charlevoix, State of Michigan, have invented certain new and useful Improvements in Mufflers for Gas-Engines, of which the following is a specification, reference being had therein to the accompanying drawings, in which—

Figure 1 is a longitudinal sectional view; Fig. 2, a transverse sectional view on the line 11 11 of Fig. 1, and Fig. 3 a longitudinal sectional view showing the muffler used in tandem.

The object of this invention is to provide the muffler with a circuitous path through a series of chambers gradually increasing in size, which will effectively reduce the powerful intermittent exhaust impulses from the engine-cylinder to a noiseless and approximately uniform speed at the exhaust end of the muffler, as more fully hereinafter set forth.

To the accomplishment of this object and such others as may hereinafter appear, the invention consists of the parts and combination of parts hereinafter fully described, and particularly pointed out in the appended claims, reference being had to the accompanying drawings, forming a part of this specification, in which the same reference characters designate like parts throughout the several views.

Referring to the various parts by numerals, 1 designates the outer cylinder or casing, 2 the exhaust-head thereof, and 3 the inlet-head, these heads being secured within the ends of the outer casing. The inlet-head is provided with a central opening 4 to receive the exhaust-pipe from the gas-engine cylinder. Within the casing 1 and a suitable distance from the inlet-head 2 is a transverse partition or wall 5, which forms, with the head 2, a large expansion-chamber 2^a. This wall is formed at its center with an outward-extending substantially conical spreader 7, the point of said spreader being axially in line with the center of the outlet 4. The wall of the spreader curves outward, as shown, and joins the outer face of the partition in such a man-

ner that the outflowing gas will be diverted outward through the opening in head 2.

The partition 5 is formed on its inner surface with an inward-extending annular flange 8, to which is secured one end of a cylinder 9, said cylinder being concentric with the outer casing 1 and of considerably smaller diameter, so that an annular expansion-chamber 10 is formed between the two cylinders. This partition is also provided with an annular series of perforations 11, which put the expansion-chamber 2^a in communication with the chamber 10. The cylinder 9 terminates short of the head 3. The head 3 is formed with a central annular inward-extending flange 12, which is considerably smaller in diameter than the cylinder 9, and secured to and inclosing said annular flange is a central cylinder 13, whose free end terminates short of the partition 5. The inner surface of the head 3 outside of the flange 12 is formed concave in order to direct the expanding gas from the space 14 into the space 10 between the cylinder 9 and the casing 13. The partition 5 on its inner face is formed with an annular concave channel which forms a central substantially conical projection 15, the walls of said channel directing the gas into cylinder 9 and toward the exhaust. The outlet through the exhaust-head is preferably of substantially the same area as the inlet.

The operation of the device is apparent from the foregoing description, and a detail description thereof is deemed unnecessary.

It will be apparent to those skilled in the art that various mechanical embodiments of the invention are possible, and I therefore do not wish to be limited to the exact arrangement and construction shown. For instance, two of the mufflers may be arranged in tandem, as shown in Fig. 3, for use on larger engines without departing from the spirit of the invention.

What I claim, and desire to secure by Letters Patent, is—

1. A muffler, consisting of a casing provided with a head at each end thereof, each head being provided with an opening, a partition in the casing provided with an annular series of

openings near the casing, said partition forming an expansion-chamber between it and one of the heads, an open-ended tube attached to this partition inside of said series of openings
5 and extending to near the opposite head, and another tube attached to this latter head over its opening and extending to near said partition, whereby a circuitous passage is formed
10 between one head and the partition, and an expansion-chamber is formed between the other head and the partition.

2. A muffler, consisting of a casing provided with a head at each end thereof, each head being provided with an opening, a partition in
15 the casing provided with an annular series of openings near the casing, said partition forming an expansion-chamber between it and one of the heads, an open-ended tube attached to this partition inside of said series of openings

and extending to near the opposite head, and
20 another tube attached to this latter head over its opening and extending to near said partition, whereby a circuitous passage is formed between one head and the partition, and an expansion-chamber is formed between the other
25 head and the partition, and another muffler device arranged tandem to the aforesaid muffler and constructed substantially like said muffler, the exhaust-head of the first muffler serving as the inlet-head of the second muffler, for the purpose set forth. 30

In testimony whereof I hereunto affix my signature, in the presence of two witnesses, this 24th day of August, 1904.

DANIEL G. WILLIAMS.

Witnesses:

ALDEN E. CROSS,
GEO. G. WILLIAMS.