

12

**EUROPEAN PATENT APPLICATION**

21 Application number: 79303076.8

51 Int. Cl.<sup>3</sup>: F 02 M 29/04

22 Date of filing: 31.12.79

30 Priority: 29.12.78 US 973240

43 Date of publication of application:  
09.07.80 Bulletin 80/14

84 Designated Contracting States:  
AT BE CH DE FR GB IT LU NL SE

71 Applicant: Johnson, Edward E.  
2107 Plymouth Rock  
Richardson, Texas 75081(US)

72 Inventor: Johnson, Edward E.  
2107 Plymouth Rock  
Richardson, Texas 75081(US)

74 Representative: Potter, Willoughby Whatnall et al,  
ERIC POTTER & CLARKSON 14 Oxford Street  
Nottingham NG1 5BP(GB)

54 Intake manifold fuel atomizing screen.

57 A dished screen (11) placed in engine intake manifold openings (13) beneath a carburetor (17) in the path of intake air flow with, under a one-barrel carburetor one recess dished screen being used, and with a two-barrel carburetor two recess dished screens being used. The screen units are positioned so that fuel laden air from the carburetor (17) passes through screening of the screen units (11) with the mesh and wire size of the screening coupled with depressed dished shape of the screen units such as to optimize vaporization atomizing of fuel in the fuel air mixture being fed to the engine.

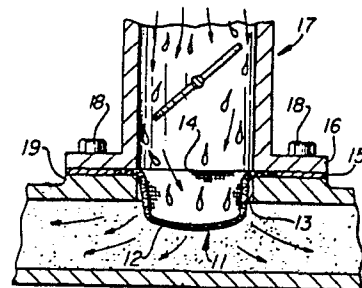

FIG. 1

INTAKE MANIFOLD  
FUEL ATOMIZING SCREEN

This invention relates in general to vaporization of liquid fuel fed to internal combustion engines and, in particular, to a liquid fuel vaporizing screen unit. The unit may be used singly or in multiple depending upon  
5 whether a carburetor is a one-barrel or multi-barrel carburetor feeding corresponding intake manifold openings. Each screen unit is positioned in a manifold intake opening such that fuel laden air from the carburetor passes through screening of the screen units with screen mesh and wire  
10 size coupled with depressed dish shape of the screen units such as to optimize vaporization atomizing of fuel in the fuel air mixture being fed to the engine.

Fuel economy is an increasingly important consideration in vehicles, particularly with present energy problems  
15 and fuel shortages and constantly increasing fuel costs. Further, present day problems of environmental pollution have resulted in legislative action requiring more efficient engines with less pollution to meet tighter emission standards. In meeting such standards, exhaust gas recircu-  
20 lation, catalytic converters and/or auxiliary air pumps and other associated controls are designed into vehicles, both passenger cars and trucks, resulting in greatly increased vehicle costs. Still further, addition of such additional pollution control equipment is a further power  
25 drain on the vehicle engine further decreasing efficiency. Obviously, if engine efficiency can be increased to the point that pollution control devices are no longer needed in meeting tightened pollution standards still further increases in efficiency are attainable through the lessened  
30 power loading with removal of driven equipment. If engine efficiency is such that catalytic converters and/or other pollution control devices are not needed then the range of fuels useable is expanded and the engine may be tuned for optimum engine efficiency and not for optimized pollution

control device efficiency.

With engines employing conventional carburetors for fuel vaporization a portion of the intake air is used to break the fuel into fine droplets. Since droplet size varies with intake air speed and intake air speed varies over a wide range droplet size varies from smaller droplets at higher intake air speeds to larger droplets at lower intake air speeds. It should be noted that there is some beneficial gasification of the fuel in the carburetor and delivery through intake manifolding. However, much of the fuel remains in the form of droplets of varying sizes passed into the intake manifold with much of air fuel mixing occurring downstream from the carburetor resulting in uneven cylinder to cylinder distribution. More complete vaporization of the fuel leads to more uniform mixing of fuel with air in the carburetor area and through the engine intake manifold. Further, the more completely fuel is transformed to a vapor as opposed to a mist droplet state the efficiency of combustion in the cylinder is improved.

It is an object of this invention to provide improved engine fuel feed gas vaporization, increase internal combustion engine efficiency and also to reduce emission pollution.

According to the present invention I provide in a fuel atomizing screen for installation in internal combustion engine intake manifold openings beneath engine carburetors: a screen unit of relatively fine mesh screening (preferably of stainless steel wire) having a depending formed depression sized to fit the intake opening of the intake manifold beneath a barrel of a carburetor with the depending formed depression extending down and away from the carburetor.

Reference is now made to the accompanying drawings:

Figure 1 represents a partially broken away and sectioned elevation view of a carburetor mounted on an intake manifold with an air/liquid fuel vaporizing screen

unit positioned in an intake opening of the intake manifold with the mounting flange of the screen unit held between the carburetor mounting boss of the intake manifold and the mounting base of the carburetor;

5 Figure 2, a perspective view of a screen unit as used in the carburetor intake manifold assembly of Figure 1;

Figures 3 and 4, side elevation views of other screen unit configuration embodiments that may be used in intake manifold openings in place of the screen unit of Figures  
10 1 and 2; and,

Figure 5, an exploded perspective view of a two-barrel carburetor and intake manifold combination also including an air valve in a (PCV) positive crankcase ventilation system control valve line.

15 Referring to the drawing:

The intake manifold 10 fuel atomizing screen unit 11 of Figures 1 and 2 is shown to be held in place with the dished bowl 12 thereof extending down into and through intake opening 13 of the engine intake manifold 10 with  
20 annular screen flange 14 tightly held in place by carburetor gasket 15 clamped under the mounting flange 16 of carburetor 17, fastened by bolts 18 to the carburetor mounting boss 19 of the intake manifold 10. The screen unit 11' of  
25 Figure 3 is an alternate screen unit embodiment with a rounded hemospheric like formed depression 12' depending from annular flange 14' with screen unit 11' useable in place of screen unit 11 in the intake manifold one-barrel carburetor combination of Figure 1 or in a plurality of  
30 intake openings 13' such as with the two barrel carburetor 17' and intake manifold 10' combination of Figure 5. In like manner the alternate screen unit 11" embodiment of Figure 4 having a conical depression 12" depending from annular flange 14" may be used in the combination of  
35 Figure 1 or that of Figure 5 in place of the screen units 11 or 11'.

Screen units 11, 11' or 11", which may also be called screen baskets, may be formed to fit different engine

intake manifold openings 13 but a typical screen unit size at the depression perimeter diameter is approximately one and one-half inches, a flange extension of about one quarter of an inch and a bowl depth of approximately three quarters of an inch. Stainless steel wire or copper wire screen mesh with a 60-40 mesh of 0.010 inch diameter wire has proven to be a particularly good mesh from which screen units, 11, 11' or 11" may be formed in providing excellent operational results. The screen units intercept course fuel droplets dispersed in the airstream and atomize the fuel droplets in turbulence in the screen and about the wires of the screen units in creating a suspension of minute fuel particles in the air downstream from the screen units in an air/fuel mist flowing to the cylinders through the intake manifold 10 as shown diagrammatically in Figure 1. The downward depressed dishes or bowls of screen units 11, 11' or 11" increase the screen area for passage of fuel/air mixture therethrough with minimized obstruction to through flow of fuel laden air to the engine cylinders. Tests with a number of automobiles have shown beneficial operational results with mileage increase generally falling in a range of 20% to 50% increase. This also, with more complete burning of fuel in the engine, results in improved significant reduction of noxious contaminant emissions. It is of interest to note that the downward depending walls of screen units 11, 11' and 11" extend inward and away from the walls of intake manifold openings 13 in Figure 1 or 13' in Figure 5 in insuring that the full area of the downward formed depressions or bowls be effective in passing fuel and air mixture through flow.

Screen units 11, 11' and 11" and in other variation modifications thereof to fit various intake manifold openings under carburetors for various engines are useable not only with a single-barrel carburetor such as in Figure 1, but with two-barrel carburetors 17' and a two-intake-hole 13' manifold 10' such as in Figure 5. Obviously, screen

units 11, 11' and 11" may also be used with four-barrel carburetors (not shown) in much the same manner with, in some instances, screen units used in only the two front intake manifold openings and in others in all four manifold openings. In the two-barrel carburetor showing of Figure 5 the screen units 11 are shown as being in place with flanges 14 above gasket 15' rather than below gasket 15 as shown in Figure 1. With screen units 11 in place the carburetor 17' is fastened in place with bolts 18' extended through holes 20 in carburetor mounting flange 21 into intake manifold carburetor mounting boss 19'. With the installation of Figure 5 set screw 22 adjustable vacuum T unit 23 is inserted in line 24 interconnecting PCV valve 25 and carburetor 17' and on through line 26 to the engine for passage of engine crankcase blow-by gases back to the carburetor 17' and fed into the intake air flow.

The set screw 22 of vacuum T unit 23 in line 24 is set to achieve fast idle with air bleed through the vacuum T 23 bleed opening 27 to line 24. Then after adjusting set screw 22 the carburetor linkage is set to idle in accord with factory specifications.

With two screen units 11 (11' or 11") and a vacuum T furnished as a field modification kit installation is made as follows:

- 25 1. Remove carburetor.
2. Insert screen baskets into intake manifold in front two holes, if you have a 4-barrel carburetor. If you have a 2-barrel carburetor, insert the screen baskets in the two holes under carburetor.
- 30 3. Replace carburetor. (Make sure you have the right carburetor gasket.)
4. Start motor and check for vacuum leak.
5. Insert vacuum T into PCV vacuum line.
6. Adjust set screw on top of T to achieve fast idle.
- 35 7. After adjusting set screw make sure you set carburetor linkage idle to factory specifications.

To insert T into PCV vacuum line, cut rubber line with knife. (No clamps are necessary.)

Please note that with factory installation carburetors may be provided with an air bleed adjustment eliminating the requirement for addition of a vacuum T 23 in a PCV line 24.

Whereas this invention is herein illustrated and described with respect to several embodiments thereof, it should be realized that various changes may be made without departing from essential contributions to the art made by the teachings hereof.

CLAIMS

1. In a fuel atomizing screen for installation in internal combustion engine intake manifold openings beneath engine carburetors: a screen unit of relatively fine mesh screening (preferably of stainless steel wire) having a depending formed depression sized to fit the intake opening of the intake manifold beneath a barrel of a carburetor with the depending formed depression extending down and away from the carburetor.
2. A fuel atomizing screen according to Claim 1, also including a mounting flange surrounding the upper peripheral edge of the depending formed depression sized to be clamped with a carburetor gasket between the carburetor and a carburetor mounting boss on an intake manifold.
3. A fuel atomizing screen according to Claim 2, wherein said mounting flange is an annular extension of the mesh screening forming said depending formed depression.
4. A fuel atomizing screen according to any of claims 1 to 3, wherein said depending formed depression has walls angled inward and away from the wall of said intake opening.
5. A fuel atomizing screen according to Claim 4, wherein said depending formed depression is a depressed dish shape.
6. A fuel atomizing screen according to Claim 4, wherein said depending formed depression is a depressed rounded hemospheric-like formed depression.
7. A fuel atomizing screen according to Claim 4, wherein said depending formed depression is generally a conical depression.
8. A fuel atomizing screen according to any of claims 1 to 7, wherein said screening is at most a 30-30 mesh screen with maximum wire diameter of 0.020 inches.
9. A fuel atomizing screen according to any of claims 1 to 7, wherein said screen unit is formed of one piece of approximately 60-40 mesh screening of approximately 0.010 inch diameter wire.

10. A fuel atomizing screen according to any of claims 1 to 9, wherein at least one of said fuel atomizing screens is supplied as part of a field installation kit also including a set screw equipped vacuum T fitting for PCV line installation carburetor adjustment when fuel atomizing screening is in place in an intake manifold opening beneath a carburetor.

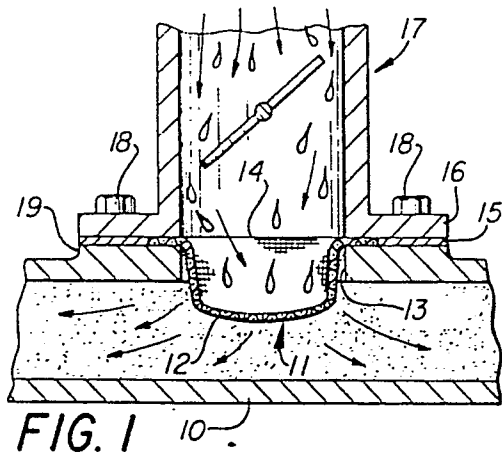

FIG. 1

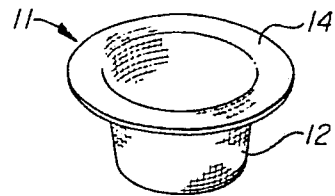

FIG. 2

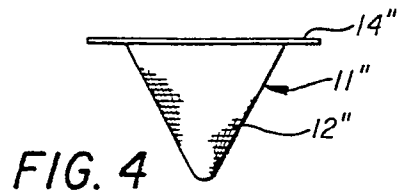

FIG. 4



FIG. 3

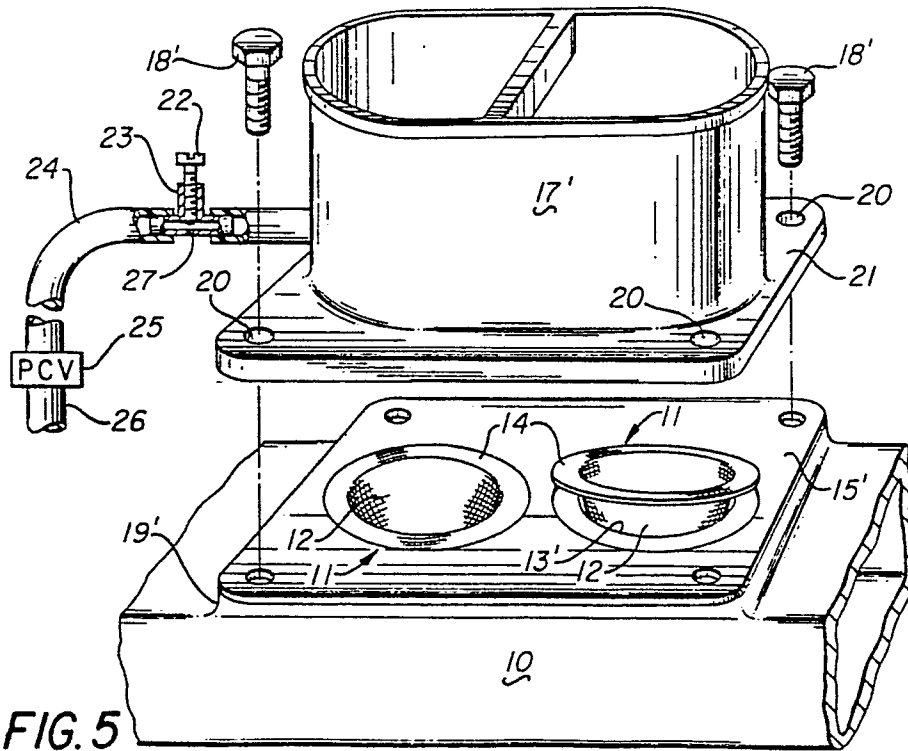

FIG. 5



DOCUMENTS CONSIDERED TO BE RELEVANT			CLASSIFICATION OF THE APPLICATION (Int. Cl.)
Category	Citation of document with indication, where appropriate, of relevant passages	Relevant to claim	
X	DE - U - 6 909 538 (KAZMIEROWSKI) * whole document * --	1-6	F 02 M 29/04
	US - A - 1 533 364 (BARROTT) * page 2, line 83 to page 3, line 9; fig. 1, position 23 * --	7	
	US - A - 3 885 539 (HICKS) * column 6, lines 10 to 19 * --	8,9	
A	DE - U - 7 119 219 (ROLAND) * claims; fig. * --		TECHNICAL FIELDS SEARCHED (Int. Cl.)
A	DE - A - 2 035 428 (ROLANDO) * claims; fig. 2 * --		F 02 M 23/00 F 02 M 29/00
A	US - A - 4 023 544 (COLE) * column 2, lines 30 to 34 * --		
A	US - A - 2 535 410 (GREVAS) * fig.; position 19 * --		CATEGORY OF CITED DOCUMENTS
A	US - A - 1 526 963 (CHANDLER) * fig. 2, position 28 * ----		X: particularly relevant A: technological background O: non-written disclosure P: intermediate document T: theory or principle underlying the invention E: conflicting application D: document cited in the application L: citation for other reasons
<input checked="" type="checkbox"/> The present search report has been drawn up for all claims			&: member of the same patent family. corresponding document
Place of search	Date of completion of the search	Examiner	
Berlin	13-03-1980	STÖCKLE	