

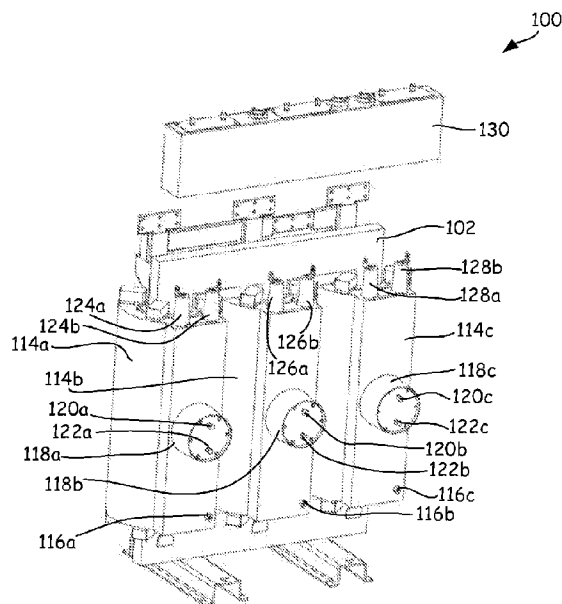

(86) Date de dépôt PCT/PCT Filing Date: 2018/03/08  
(87) Date publication PCT/PCT Publication Date: 2019/09/12  
(45) Date de délivrance/Issue Date: 2020/12/08  
(85) Entrée phase nationale/National Entry: 2020/09/04  
(86) N° demande PCT/PCT Application No.: CN 2018/078427  
(87) N° publication PCT/PCT Publication No.: 2019/169605

(51) Cl.Int./Int.Cl. *H01F 27/29* (2006.01),  
*H01F 27/30* (2006.01)  
(72) Inventeurs/Inventors:  
NAVARRO, MARTIN ALSINA, BR;  
WANG, YAOQIANG, CN;  
MORENO, ANDRE LUIZ, BR;  
ZHANG, MING, CN;  
YU, XIONG, CN  
(73) Propriétaires/Owners:  
SIEMENS AKTIENGESELLSCHAFT, DE;  
HAINAN JINPAN SMART TECHNOLOGY CO., LTD., CN  
(74) Agent: SMART & BIGGAR LLP

(54) Titre : PROCÉDES, APPAREIL ET SYSTEMES DE TRANSFORMATEURS DE TYPE SEC  
(54) Title: METHODS, APPARATUS AND SYSTEMS FOR DRY-TYPE TRANSFORMERS



(57) **Abrégé/Abstract:**

In some embodiments, a connection bar is provided for connecting multiple high voltage coils of a dry-type transformer along a top or bottom of the dry-type transformer. The connection bar includes (1) an electrically insulating body having a plurality of openings, each opening sized to receive at least one of high voltage terminals of the transformer; (2) an electrical connection pathway within the electrically insulating body configured to create a predetermined electrical connection between multiple high voltage coils of the transformer; (3) external connector terminals embedded within and extending from the electrically insulating body, the external connector terminals connected to the electrical connection pathway; and (4) a ground shield embedded within the electrically insulating body and configured to shield high voltage terminals of each high voltage coil of the transformer. Numerous other aspects are provided.

## (12) INTERNATIONAL APPLICATION PUBLISHED UNDER THE PATENT COOPERATION TREATY (PCT)

(19) World Intellectual Property  
Organization  
International Bureau

(43) International Publication Date  
12 September 2019 (12.09.2019)



(10) International Publication Number  
**WO 2019/169605 A1**

- (51) **International Patent Classification:**  
*H01F 27/29* (2006.01) *H01F 27/30* (2006.01)
- (21) **International Application Number:**  
PCT/CN2018/078427
- (22) **International Filing Date:**  
08 March 2018 (08.03.2018)
- (25) **Filing Language:** English
- (26) **Publication Language:** English
- (71) **Applicants:** **SIEMENS AKTIENGESELLSCHAFT** [DE/DE]; Werner-von-Siemens-Straße 1, 80333 München (DE). **HAINAN JINPAN SMART TECHNOLOGY CO., LTD.** [CN/CN]; No. 168-39 Nanhai Avenue, Haikou, Hainan (CN).
- (72) **Inventors; and**
- (71) **Applicants (for AL only):** **NAVARRO, Martin Alsina** [ES/BR]; Rua Afonso Celso 20, 13219-710 Jun-diai, SP (BR). **WANG, Yaoqiang** [CN/CN]; D1-1706 Vanke Hanyang International, Wuhan, Hubei 430000 (CN). **MORENO, Andre Luiz** [BR/BR]; Av. do Pinheirinho 280, 13224-240 Varzea Paulista (BR). **ZHANG, Ming** [CN/CN]; Gaoxin 2nd. Road Hainan, Wuhan, Hubei 430000 (CN). **YU, Xiong** [CN/CN]; Gaoxin 2nd. Road Hainan, Wuhan, Hubei 430000 (CN).
- (74) **Agent:** **KANGXIN PARTNERS, P.C.**; Floor 16, Tower A, InDo Building, A48 Zhichun Road, Haidian District, Beijing, 100098 (CN).
- (81) **Designated States (unless otherwise indicated, for every kind of national protection available):** AE, AG, AL, AM, AO, AT, AU, AZ, BA, BB, BG, BH, BN, BR, BW, BY, BZ, CA, CH, CL, CN, CO, CR, CU, CZ, DE, DJ, DK, DM, DO, DZ, EC, EE, EG, ES, FI, GB, GD, GE, GH, GM, GT, HN, HR, HU, ID, IL, IN, IR, IS, JO, JP, KE, KG, KH, KN, KP, KR, KW, KZ, LA, LC, LK, LR, LS, LU, LY, MA, MD, ME, MG, MK, MN, MW, MX, MY, MZ, NA, NG, NI, NO, NZ, OM, PA, PE, PG, PH, PL, PT, QA, RO, RS, RU, RW, SA, SC, SD, SE, SG, SK, SL, SM, ST, SV, SY, TH, TJ, TM, TN, TR, TT, TZ, UA, UG, US, UZ, VC, VN, ZA, ZM, ZW.
- (84) **Designated States (unless otherwise indicated, for every kind of regional protection available):** ARIPO (BW, GH, GM, KE, LR, LS, MW, MZ, NA, RW, SD, SL, ST, SZ, TZ, UG, ZM, ZW), Eurasian (AM, AZ, BY, KG, KZ, RU, TJ, TM), European (AL, AT, BE, BG, CH, CY, CZ, DE, DK, EE, ES, FI, FR, GB, GR, HR, HU, IE, IS, IT, LT, LU, LV, MC, MK, MT, NL, NO, PL, PT, RO, RS, SE, SI, SK, SM,

(54) **Title:** METHODS, APPARATUS AND SYSTEMS FOR DRY-TYPE TRANSFORMERS

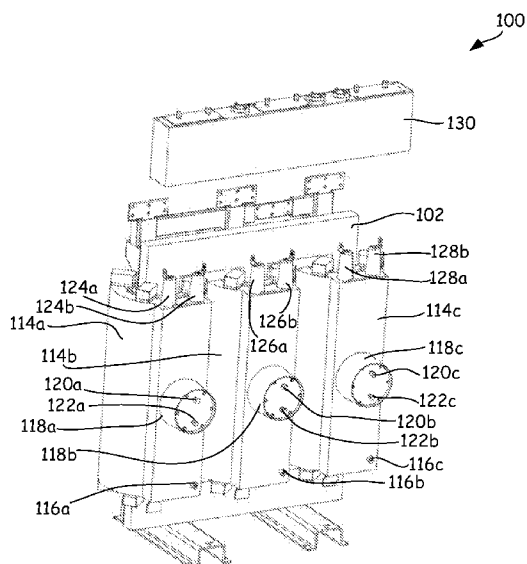

FIG. 1A

(57) **Abstract:** In some embodiments, a connection bar is provided for connecting multiple high voltage coils of a dry-type transformer along a top or bottom of the dry-type transformer. The connection bar includes (1) an electrically insulating body having a plurality of openings, each opening sized to receive at least one of high voltage terminals of the transformer; (2) an electrical connection pathway within the electrically insulating body configured to create a predetermined electrical connection between multiple high voltage coils of the transformer; (3) external connector terminals embedded within and extending from the electrically insulating body, the external connector terminals connected to the electrical connection pathway; and (4) a ground shield embedded within the electrically insulating body and configured to shield high voltage terminals of each high voltage coil of the transformer. Numerous other aspects are provided.

[Continued on next page]

WO 2019/169605 A1

**WO 2019/169605 A1** 

---

TR), OAPI (BF, BJ, CF, CG, CI, CM, GA, GN, GQ, GW,  
KM, ML, MR, NE, SN, TD, TG).

**Published:**

— *with international search report (Art. 21(3))*

**METHODS, APPARATUS AND SYSTEMS FOR  
DRY-TYPE TRANSFORMERS**

**FIELD**

[001] This application relates generally to transformers used for electric power distribution, and more particularly to methods, apparatus and systems for dry-type transformers.

**BACKGROUND**

[002] Transformers are employed to increase or decrease voltage levels during electrical power distribution. To transmit electrical power over a long distance, a transformer may be used to raise the voltage and reduce the current of the power being transmitted. A reduced current level reduces resistive power losses from the electrical cables used to transmit the power. When the power is to be consumed, a transformer may be employed to reduce the voltage level, and increase the current, of the power to a level required by the end user.

[003] One type of transformer that may be employed is a dry, submersible transformer, as described, for example, in U.S. Patent No. 8,614,614. Such transformers may be employed underground, in cities, etc., and may be designed to withstand harsh environments such as water exposure, humidity, pollution and the like. Improved methods, apparatus and systems for submersible and other dry-type transformers are desired.

**SUMMARY**

[004] In some embodiments, a connection bar is provided for connecting multiple high voltage coils of a dry-type

transformer along a top or bottom of the dry-type transformer. The connection bar includes (1) an electrically insulating body sized to extend across high voltage terminals of multiple high voltage coils of the transformer, the electrically insulating body having a plurality of openings that extend into the electrically insulating body, each opening sized to receive at least one of the high voltage terminals of a respective one of the high voltage coils of the transformer; (2) an electrical connection pathway within the electrically insulating body, the electrical connection pathway extending between the plurality of openings and configured to create a predetermined electrical connection between multiple high voltage coils of the transformer; (3) external connector terminals embedded within and extending from the electrically insulating body, the external connector terminals connected to the electrical connection pathway; and (4) a ground shield embedded within the electrically insulating body and configured to shield high voltage terminals of each high voltage coil of the transformer.

[005] In some embodiments, a dry-type transformer includes (1) a plurality of high voltage coils, each including two high voltage terminals positioned at a top or bottom of the high voltage coil; (2) a connection bar positioned to extend across the plurality of high voltage coils, the connection bar including: (3) an electrically insulating body sized to extend across the high voltage terminals of the high voltage coils of the transformer, the electrically insulating body having a plurality of openings that extend into the electrically insulating body, each opening sized to receive at least one of the high voltage terminals of a respective one of the high voltage coils of the transformer; (4) an electrical connection

pathway within the electrically insulating body, the electrical connection pathway extending between the high voltage terminals within the plurality of openings so as to create a predetermined electrical connection between the multiple high voltage coils of the transformer; and (5) external connector terminals embedded within and extending from the electrically insulating body, the external connector terminals connected to the electrical connection pathway.

[006] In some embodiments, a method is provided of forming a dry-type transformer. The method includes (1) providing a plurality of high voltage coils, each including two high voltage terminals positioned at a top or bottom of the high voltage coil; (2) providing a connection bar including (a) an electrically insulating body sized to extend across the high voltage terminals of the high voltage coils of the transformer, the electrically insulating body having a plurality of openings that extend into the electrically insulating body, each opening sized to receive at least one the high voltage terminals of a respective one of the high voltage coils of the transformer; (b) an electrical connection pathway within the electrically insulating body, the electrical connection pathway extending between the high voltage terminals within the plurality of openings so as to create a predetermined electrical connection between the multiple high voltage coils of the transformer; and (c) external connector terminals embedded within and extending from the electrically insulating body, the external connector terminals connected to the electrical connection pathway. The method further includes (3) positioning the connection bar so that each high voltage terminal of each high voltage coil is positioned within a respective opening of the plurality of openings in the

electrically insulating body; and (4) coupling each high voltage terminal of each high voltage coil to the electrical connection pathway.

[007] In some embodiments, a method is provided of forming a connection bar for connecting multiple high voltage coils of a dry-type transformer along a top or bottom of the transformer. The method includes (1) forming an electrically insulating body sized to extend across high voltage terminals of multiple high voltage coils of the transformer, the electrically insulating body having a plurality of openings that extend into the electrically insulating body, each opening sized to receive at least one of the high voltage terminals of a respective one of the high voltage coils of the transformer; (2) forming an electrical connection pathway within the electrically insulating body, the electrical connection pathway extending between the plurality of openings and configured to create a predetermined electrical connection between multiple high voltage coils of the transformer; (3) forming external connector terminals embedded within and extending from the electrically insulating body, the external connector terminals connected to the electrical connection pathway; and (4) forming a ground shield embedded within the electrically insulating body and configured to shield high voltage terminals of each high voltage coil of the transformer.

[008] Still other aspects, features, and advantages of this disclosure may be readily apparent from the following detailed description illustrated by a number of example embodiments and implementations. This disclosure may also be capable of other and different embodiments, and its several details may be modified in various respects. Accordingly, the

drawings and descriptions are to be regarded as illustrative in nature, and not as restrictive. The drawings are not necessarily drawn to scale.

#### BRIEF DESCRIPTION OF THE DRAWINGS

[009] FIG. 1A is a side perspective view of a submersible dry-type transformer in accordance with embodiments provided herein.

[0010] FIG. 1B is a side view of a core in accordance with embodiments provided herein.

[0011] FIG. 1C is a cross sectional view of the core of FIG. 1B taken along line 1C-1C in FIG. 1B.

[0012] FIGS. 2A and 2B are top and bottom perspective views, respectively, of a first example embodiment of a connection bar provided herein.

[0013] FIG. 2C is another top perspective view of the first example embodiment of the connection bar of FIGS. 2A-2B provided herein.

[0014] FIGS. 3A and 3B are a side view and top view, respectively, of an example embodiment of the connection bar of FIGS. 2A-2C provided herein.

[0015] FIG. 3C is a side view of an alternative embodiment of the connection bar of FIGS. 3A-3B in which the openings are not tapered.

[0016] FIG. 3D is a side view of another alternative embodiment of the connection bar of FIGS. 3A-3B in which each high voltage terminal is positioned in a different opening.

[0017] FIGS. 4A and 4B are top schematic views of a connection bar configured to provide a first delta connection in accordance with embodiments herein.

[0018] FIGS. 4C and 4D are top schematic views of a connection bar configured to provide a second delta connection in accordance with embodiments herein.

[0019] FIGS. 5A and 5B are top schematic views of a connection bar configured to provide a first wye connection in accordance with embodiments herein.

[0020] FIG. 6 is a top schematic view of a connection bar configured to provide series connected high voltage coils (e.g., single phase) in accordance with embodiments herein.

[0021] FIG. 7A is a side schematic view of an example embodiment of a three-phase submersible dry-type transformer employing a connection bar as provided herein.

[0022] FIG. 7B is a side schematic view of an example embodiment of a three-phase submersible dry-type transformer employing a connection bar with an opening for each high voltage terminal as provided herein.

[0023] FIG. 7C is a side schematic view of an alternative example embodiment of a three-phase submersible dry-type transformer employing a connection bar as provided herein.

[0024] FIGS. 8A and 8B are side schematic views of another example embodiment of a three-phase submersible dry-type transformer employing a connection bar on a bottom of the transformer as provided herein.

[0025] FIG. 9 is a side schematic view of another example embodiment of a three-phase submersible dry-type transformer

employing a connection bar and which includes selectable coil taps on high voltage terminals as provided herein.

#### **DETAILED DESCRIPTION**

[0026] As mentioned above, submersible dry-type transformers may be employed underground and/or in other environments that may expose the transformers to water, humidity, pollutants, etc. Such transformers are often connected to deliver multiple phases of electrical power, such as 2-phase, 3-phase or more phases. Common 3-phase configurations include, for example, delta and wye connected transformers.

[0027] Conventional delta connections for submersible dry-type transformers are made on a front side of the transformers. For example, each high voltage coil of a transformer may have two high voltage terminals which protrude from the front side of the transformer, and multiple cables (e.g., three) may be fastened to the protruding terminals to create the delta connection between the high voltage coils. Wye or other connections may be similarly created using the protruding external high voltage terminals.

[0028] Use of high voltage terminals and cable connections on a front side of the transformer increases the footprint of the transformer. For example, the terminals and cables of a delta-connected transformer may be the most (laterally) external features of the transformer. If such a transformer is subjected to a side impact, whether from an external object, maintenance personnel, or the like, the high voltage terminals and/or cables may be damaged. Damage to the functionality of the transformer may result, such as damage to the high voltage

terminals, insulation of the transformer or cables, etc. Damage to the cables and/or transformer insulation may expose individuals in the vicinity of the transformer to potentially lethal voltage and/or currents.

[0029] In accordance with one or more embodiments described herein, submersible dry-type transformers are provided that have high voltage terminals located above or below the transformers, rather than on a front side of the transformers. In some embodiments, high voltage coils of a submersible dry-type transformer are connected, such as in a delta or wye configuration, through use of a connection bar located at a top of or below the transformer. The connection bar replaces the need for multiple individual cables and moves the connections between high voltage terminals of a transformer from a front side of the transformer to a top side of or below the transformer. The connection bar may be formed from an insulating material, such as an epoxy resin, that protects and/or isolates the electrical connections between high voltage coils from external environments, including impacts. Likewise, maintenance or other personnel are isolated and/or protected from the electrical connections between the high voltage terminals of the coils.

[0030] Placing the high voltage terminals above or below the transformer, and using the connecting bar for creating multiple coil connections (e.g., delta and/or wye connections), reduces the overall footprint of the transformer. The transformer is less susceptible to damage from side impacts, and safer for maintenance personnel. Manufacturing costs also may be reduced as shielding of the transformer is simplified by elimination of the front side high voltage terminals.

[0031] FIG. 1A is a side perspective view of a submersible dry-type transformer 100 in accordance with embodiments provided herein. The transformer 100 shown is a three-phase transformer, but in other embodiments, transformers with different number of phases may be employed (e.g., one, two, four, five, etc.).

[0032] Transformer 100 includes a core 102. FIG. 1B is a side view of core 102, and FIG. 1C is a cross sectional view of core 102 taken along line 1C-1C in FIG. 1B. Core 102 may be a solid core or a core formed from multiple sheets of core materials. Example core materials include iron, steel, amorphous steel or other amorphous metals, silicon-steel alloy, carbonyl iron, ferrite ceramics, laminated layers of one or more of the above materials, or the like.

[0033] As shown in FIG. 1B, core 102 includes core columns 104a, 104b and 104c. In some embodiments, within transformer 100, each core column 104a, 104b and 104c is surrounded by a low voltage coil 106a-c and a high voltage coil 108a-c, which may be concentric. Note that coils may also be referred to as windings. Low voltage coils 106a-c may be electrically isolated from core 102 and from high voltage coils 108a-c. For example, low voltage coils 106a-c may be surrounded by an insulating material such as a resin (not shown) and high voltage coils 108a-c may have insulating material (e.g., resin) and shielding (not shown) on both sides of the high voltage coils 108a-c. In some embodiments, a first space 110 between the core 102 (core columns 104a-c) and low voltage coils 106a-c may have air, water or both. Similarly, a second space 112 between the low voltage coils 106a-c and high voltage coils 108a-c may have air, water or both. Example insulating

materials include a solid insulation, such as an epoxy resin, polyurethane, polyester, silicone, etc. An example epoxy resin is a synthetic rubber such as polybutadiene, for example, High Gel Re-Enterable Encapsulant 8882 available by 3M of St. Paul, Minnesota.

[0034] Referring again to FIG. 1A, the high voltage coils 108a-c (FIG. 1C) are surrounded by transformer housings 114a-c. Transformer housings 114a-c may be formed from any suitable material, such as a metal (e.g., aluminum), and are electrically isolated from high voltage coils 108a-c using a solid insulation (not shown) such as epoxy resin, polyurethane, polyester, silicone, or the like, for example. Transformer housings 114a-c may be electrically grounded via grounding connections 116a-c.

[0035] In some embodiments, each transformer housing 114a-c may include a window 118a-c, respectively, through which one or more of the insulations provided between core 102, low voltage coils 106a-c, high voltage coils 108a-c and/or housings 114a-c may be inserted, removed and/or replaced. For example, each housing window 118a-c may include an upper inlet 120a-c and a lower inlet 122a-c. During resin filling, vacuum may applied to one inlet, such as an upper inlet, while resin is provided to the other inlet, such as the lower inlet. Application of vacuum withdraws air from any area that will receive insulation and prevents the formation of air bubbles as the insulation fills the intended area. Formation of air bubbles may result in electrical discharge when the coils are energized. Insulation insertion and/or removal processes are described, for example, in U.S. Patent Application Publication No. US 2014/0118101 A1.

Additional details regarding an example submersible dry-type transformer that may be employed in accordance with one or more embodiments provide herein is described in previously mentioned U.S. Patent No. 8,614,614. In some embodiments, windows 118a-c may also provide access to adjustable taps (not shown) of the coils of transformer 100.

[0036] Referring again to FIG. 1A, transformer housing 114a is provided with high voltage terminals 124a, 124b positioned on top of the housing 114a. Likewise, transformer housing 114b is provided with high voltage terminals 126a, 126b positioned on top of the housing 114b; and transformer housing 114c is provided with high voltage terminals 128a, 128b positioned on top of the housing 114c. The high voltage terminals 124a-b, 126a-b and 128a-b provide electrical connections to high voltage coils 108a-c, respectively (FIG. 1C). As described further below with reference to FIGS. 2A-9, a connection bar 130 may be employed to interconnect high voltage terminals 124a-b, 126a-b and 128a-b, and thus high voltage coils 108a-c, in any desired configuration (e.g., a delta connection, a wye connection, etc.). In other embodiments, described below with reference to FIGS. 8A-8B, the high voltage terminals 124a-b, 126a-b and 128a-b may be positioned below each transformer housing 114a-c and connection bar 130 may be employed to interconnect high voltage terminals 124a-b, 126a-b and 128a-b, and thus high voltage coils 108a-c, in any desired configuration (e.g., a delta connection, a wye connection, etc.).

[0037] FIGS. 2A and 2B are top and bottom perspective views, respectively, of a first example embodiment of connection bar 130 provided herein. With reference to FIG. 2A, connection bar 130 includes an electrically insulating body 200 sized to extend across high voltage terminals of multiple high voltage coils of a submersible dry-type transformer. For example, connection bar 130 may extend across high voltage terminals 124a-b, 126a-b and 128a-b of transformer 100 of FIG. 1A.

[0038] Electrically insulating body 200 has a plurality of openings 202a-c that extend into the electrically insulating body 200, each opening sized to receive at least one of the high voltage terminals 124a-b, 126a-b and 128a-b of a respective one of the high voltage coils 108a-c of the submersible dry-type transformer 100. In some embodiments, electrically insulating body 200 may have a separate opening for each high voltage terminal of transformer 100 (e.g., six openings for a three-phase transformer that employs two high voltage terminals per coil). In other embodiments, electrically insulating body 200 may have an opening for each set of high voltage terminals of transformer 100 (e.g., three openings for a three-phase transformer that employs two high-voltage terminals per coil). In yet other embodiments, other numbers of openings may be employed.

[0039] Electrically insulating body 200 may be formed from any suitable insulating material. In some embodiments, electrically insulating body 200 may be formed from an epoxy resin, polyurethane, polyester, silicone, or the like. Other materials may be employed. Example resins include Aradur® HY 926 CH and/or Araldite® CY 5948 available from Huntsman Quimica Brasil Ltda. of Sao Paulo, Brasil.

[0040] As will be described further below, electrically insulating body 200 may include an electrical connection pathway within electrically insulating body 200. The electrical connection pathway may extend between the plurality of openings 202a-202c and be configured to create a predetermined electrical connection between multiple high voltage coils 108a-c of submersible dry-type transformer 100.

[0041] External connector terminals 204a-c may be embedded within and/or extend from one or more surfaces of the electrically insulating body 200. For example, in some embodiments, external connector terminals 204a-c may extend from a top surface of electrically insulating body 200, as shown in FIG. 2A, while in other embodiments described below, one or more external connector terminals may extend from a side surface of electrically insulating body 200. As will be described below, in some embodiments, external connector terminals 204a-c may be connected to an electrical connection pathway between openings 202a-c and high voltage terminals 124a-b, 126a-b and 128a-b. Connectors 206a-c, such as plug-in connectors, may be provided to facilitate connection of external connector terminals 204a-c to electrical cables, as shown, for example, in FIG. 2C.

[0042] In the embodiment of FIGS. 2A-C, openings 202a-c are formed in a top surface of electrically insulating body 200 and extend through to a bottom side of electrically insulating body 200 as shown in FIGS. 2A and 2B. In other embodiments described below, openings 202a-c may only extend a portion of the way into electrically insulating body 200. In the embodiment of FIGS. 2A-C, a top cover 208a, 208b and 208c is provided for each opening 202a, 202b and 202c, respectively.

Top covers 208a-208c may be formed from any suitable material. In some embodiments, top covers 208a-208c are formed from a metal such as aluminum, copper, a semi-conductive resin, a conductive foil or mesh, etc., and are grounded (e.g., to provide electrical shielding from high voltage terminals 124a-b, 126a-b and 128a-b).

[0043] FIGS. 3A and 3B are a side view and top view, respectively, of an example embodiment of the connection bar 130 of FIGS. 2A-2C provided herein. With reference to FIG. 3A, in some embodiments, openings 202a-c are tapered so that a top of each opening is wider than a bottom of the opening. Such a design may facilitate removal of the mold during casting of the electrically insulating body 200. For example, the sidewalls of the openings 202a-c may be tapered at an angle of about 10 to 20 degrees, and in some embodiments about 15 degrees, relative to vertical. Other taper angles may be employed.

[0044] As further shown in FIG. 3A, in some embodiments, openings 202a-c have internal connectors 300a-300f for making electrical contact with high voltage terminals 124a-b, 126a-b and 128a-b. For example, internal connector 300a may couple to high voltage terminal 124a, internal connector 300b may couple to high voltage terminal 124b, internal connector 300c may couple to high voltage terminal 126a, internal connector 300d may couple to high voltage terminal 126b, internal connector 300e may couple to high voltage terminal 128a, and internal connector 300f may couple to high voltage terminal 128b. In such an embodiment, to form an example delta connection between high voltage coils 108a-c, a first electrical connection pathway 304a extends between internal

connectors 300a, internal connector 300f and external connector terminal 204c; a second electrical pathway 304b extends between internal connector 300b, internal connector 300c and external connector terminal 204a; a third electrical pathway 304c extends between internal connector 300d, internal connector 300e and external connector terminal 204b. Each electrical pathway 304a-c is embedded within electrical insulating body 200 (e.g., during casting of the material used to form electrical insulating body 200). In some embodiments, internal electrical connectors 300a-f and/or electrical pathways 304a-c may be formed from copper, aluminum or another conductive material. Other materials may be used.

[0045] Electrical insulating body 200 may include an embedded ground shield 306 that extends proximate all sides of the insulating body 200 and/or around external terminal connectors 204a-c. Ground shield 306 may be grounded using a ground connection 308, for example. Ground shield 306 isolates the external surfaces of connection bar 130 from high voltage terminals 124a-b, 126a-b and 128a-b and provides a safer environment for maintenance personnel. Ground shield 306 may be cast within electrical insulating body 200 during formation, and in some embodiments may be formed from aluminum, copper, semi-conductive paint, semi-conductive resin, a metal sheet, foil or mesh, or the like, for example. Other ground shield materials may be employed.

[0046] FIG. 3C is a side view of an alternative embodiment of connection bar 130 in which openings 202a-202c are not tapered. In the embodiment of FIG. 3C, each opening 202a-202c is sized to hold two high voltage terminals. For example, opening 202a may hold high voltage terminals 124a-b, opening

202b may hold high voltage terminals 126a-b, and opening 202c may hold high voltage terminals 128a-b.

[0047] FIG. 3D is a side view of another alternative embodiment of connection bar 130 in which each high voltage terminal may be positioned in a different opening. For example, each opening may be sized to hold a single high voltage terminal. In some embodiments, opening 310a may hold high voltage terminal 124a, opening 310b may hold high voltage terminal 124b, opening 310c may hold high voltage terminal 126a, opening 310d may hold high voltage terminal 126b, opening 310e may hold high voltage terminal 128a and opening 310f may hold high voltage terminal 128b. Although not shown as tapered, in some embodiments, all or a portion of one or more of openings 310a-310f may be tapered (e.g., a top of each opening may be wider than a bottom of each opening). In general other shapes may be employed for the sidewalls of the openings 310a-310f.

[0048] Connection bar 130 may be configured to provide any desired connection between any number of high voltage terminals. FIGS. 4A and 4B are top schematic views of connection bar 130 configured to provide a first delta connection in accordance with embodiments herein. As shown in FIGS. 4A and 4B, high voltage terminals 124a-b, 126a-b and 128a-b and external connector terminals 204a-c are configured to form a delta connection (e.g., a delta-wye 1 connection) by electrical connection pathways 400a between the terminals. In the embodiment of FIG. 4A, three openings are employed for high voltage terminals 124a-b, 126a-b and 128a-b, while six openings are used in the embodiment of FIG. 4B.

[0049] FIGS. 4C and 4D are top schematic views of connection bar 130 configured to provide a second delta connection in accordance with embodiments herein. As shown in FIGS. 4C and 4D, high voltage terminals 124a-b, 126a-b and 128a-b and external connector terminals 204a-c are configured to form a delta connection (e.g., a delta-wye 11 connection) by electrical connection pathways 400b between the terminals. In the embodiment of FIG. 4C, three openings are employed for high voltage terminals 124a-b, 126a-b and 128a-b, while six openings are used in the embodiment of FIG. 4D.

[0050] FIGS. 5A and 5B are top schematic views of connection bar 130 configured to provide a first wye connection in accordance with embodiments herein. As shown in FIGS. 5A and 5B, high voltage terminals 124a-b, 126a-b and 128a-b and external connector terminals 204a-c are configured to form a wye connection by electrical connection pathways 500a between the terminals. In the embodiment of FIG. 5A, three openings are employed for high voltage terminals 124a-b, 126a-b and 128a-b, while six openings are used in the embodiment of FIG. 5B.

[0051] FIG. 6 is a top schematic view of connection bar 130 configured to provide series connected high voltage coils (e.g., single phase) in accordance with embodiments herein. As shown in FIG. 6, high voltage terminals 124a-b and 126a-b are connected in series between external connector terminals 204a-b by electrical connection pathways 600 between the terminals. In some embodiments, a separate opening may be used for each high voltage terminal.

[0052] In any of the above described embodiments, external connector terminals 204a, 204b and/or 204c may be otherwise

located (e.g., anywhere along the top surface, side surface or along multiple surfaces of the connection bar 130).

[0053] FIG. 7A is a side schematic view of an example embodiment of a three-phase submersible dry-type transformer 700 employing connection bar 130. Transformer 700 includes three encased high voltage coils (within transformer housings 114a-c) having high voltage terminals 124a-b, 126a-b and 128a-b on top of the housings 114a-c, respectively. High voltage terminals 124a-b, 126a-b and 128a-b are positioned within openings 202a-c and are connected to external connector terminals 204a-c (e.g., in a delta, wye or other desired connection as provided by electrical pathways within connection bar 130). Once positioned within openings 202a-c, high voltage terminals 124a-b, 126a-b and 128a-b are connected electrically to external connector terminals 204a-c as previously described, and then are encased in insulation (e.g., epoxy resin, polyurethane, polyester, silicone, or the like). Covers 208a-c are then placed over openings 202a-c and are electrically grounded.

[0054] As shown in FIG. 7A, connection bar 130 includes a ground shield 702a, high voltage terminals 124a-b, 126a-b and 128a-b each include a ground shield 702b, and transformer housings 114a-b each include a ground shield 702c. In some embodiments, ground shields 702a, 702b and 702c are electrically coupled. Ground shields 702a, 702b and 702c isolate the environment surrounding transformer 700 from the transformer's high voltage coils, increasing safety of transformer 700 during operation. In some embodiments, ground shields 702a, 702b and/or 702c may be formed from aluminum, copper, semi-conductive paint, semi-conductive resin, a metal

sheet, foil or mesh, or the like, for example. Other ground shield materials may be employed.

[0055] FIG. 7B is a side schematic view of an example embodiment of a three-phase submersible dry-type transformer 700 employing connection bar 130 with an opening for each high voltage terminal as provided herein.

[0056] FIG. 7C is a side schematic view of an alternative example embodiment of a three-phase submersible dry-type transformer 700 employing connection bar 130 as provided herein. In the embodiment of FIG. 7C, external connector terminals 204a-c are formed in a side surface of connection bar 130 (as opposed to in the top surface of connection bar 130 as shown in FIGS. 7A and 7B).

[0057] FIGS. 8A and 8B are side schematic views of another example embodiment of a three-phase submersible dry-type transformer 800 employing connection bar 130 on a bottom of transformer 800. Transformer 800 includes three encased high voltage coils (within transformer housings 114a-c) having high voltage terminals 124a-b, 126a-b and 128a-b on a bottom of the housings 114a-c, respectively. High voltage terminals 124a-b, 126a-b and 128a-b are positioned within openings 202a-c and are connected to external connector terminals 204a-c (e.g., in a delta, wye or other desired connection as provided by electrical pathways within connection bar 130). External connector terminals 204a-c are located on a side of connection bar 130. In some embodiments, covers (only covers 802b and 802c are shown in FIG. 8B) are then placed over openings 202a-c and are electrically grounded. High voltage terminals 124a-b, 126a-b and 128a-b (connected electrically to external connector terminals 204a-c as previously described) are

encased in insulation (e.g., epoxy resin, polyurethane, polyester, silicone, or the like). For example, each cover 802 may include an upper inlet 804a and a lower inlet 804b. In some embodiments, vacuum may be applied to one inlet, such as upper inlet 804a, while resin is provided to the other inlet, such as lower inlet 804b. Application of vacuum withdraws air from any area that will receive insulation and prevents the formation of air bubbles as the insulation fills the intended area. Formation of air bubbles may result in electrical discharge when the high voltage terminals are energized. Insulation insertion and/or removal processes are described, for example, in previously disclosed U.S. Patent Application Publication No. US 2014/0118101 A1. An example epoxy resin is a synthetic rubber such as polybutadiene, for example, High Gel Re-Enterable Encapsulant 8882 available by 3M of St. Paul, Minnesota.

[0058] As shown in FIG. 8A, connection bar 130 includes ground shield 702a, high voltage terminals 124a-b, 126a-b and 128a-b each include ground shield 702b, and transformer housings 114a-b each include ground shield 702c. In some embodiments, ground shields 702a, 702b and 702c are electrically coupled. Ground shields 702a, 702b and 702c isolate the environment surrounding transformer 800 from the transformer's high voltage coils, increasing safety of transformer 800 during operation. Transformer 800 may be positioned on any suitable support 806.

[0059] In some embodiments, one or more of high voltage terminals 124a-b, 126a-b and 128a-b may include one or more coil taps. For example, FIG. 9 is a side schematic view of another example embodiment of a three-phase submersible dry-

type transformer 900 employing connection bar 130 and which includes selectable coil taps on high voltage terminals 124b, 126b and 128b. Other configurations may be employed.

[0060] With reference to FIG. 9, transformer 900 includes three encased high voltage coils (within transformer housings 114a-c) having high voltage terminals 124a-b, 126a-b and 128a-b on a top of the housings 114a-c, respectively. High voltage terminals 124a-b, 126a-b and 128a-b are positioned within openings 310a-f and are connected to external connector terminals 204a-c (e.g., in a delta, wye or other desired connection as provided by electrical pathways within connection bar 130). External connector terminals 204a-c are located on a side of connection bar 130.

[0061] Each high voltage terminal 124b, 126b and 128b includes three tap locations, identified generally as 902a, 902b and 902c, respectively, to which a connection may be made. In some embodiments, an approximately 10% difference in voltage may be provided between the upper and lower taps of each high voltage terminal 124b, 126b and 128b, for example. Insulation may be provided between each tap to provide electrical isolation therebetween. Other tap configurations may be employed. Such taps may be used with any of the connection bars described herein.

[0062] Numerous advantages are provided by the connection bars described herein. One or more of the embodiments provided herein allows connection bar 130 to operate in air or immersed in water (e.g., up to 3 meters of water in some embodiments). Also, the footprint of a transformer is reduced by placing the connection bar 130 above or below the transformer housings 114a-c.

[0063] Submersible dry-type transformers provided in accordance with embodiments described herein may have lower material costs than other transformer designs. For example, the material cost of connection bar 130 may be lower than the cost of using cables that employ 6 plug-in bushings and 6 plug-in cable terminals. The simplicity of the casting mold and labor time required for producing a connection bar may also reduce costs.

[0064] A transformer employing a connection bar 130 has a width defined by the width of the coils, not by cables connected to a side of the transformer. The width dimension of the transformer is important because there are dimension limitations during the installation and transport. For example, a small footprint transformer may be desirable for wind farms or similar space-sensitive applications.

[0065] A transformer with a connection bar as described herein may be employed, for example, for applications in wind farms as the high voltage coils are shielded, with plug-in bushings or with bushings for external cables for an overhead distribution network, for outdoor transformer applications, for underground distribution network applications, for high voltage applications (e.g., 36 kV, 69 kV, 72 kV or 110 kV), and/or for any other suitable application.

[0066] Placing connection bar 130 above or below a transformer may reduce stress on the transformer by allowing more expansion of the conductors of the transformer's high voltage coils. Heating of the high voltage coils and transformer rating depend on the thermal capability of the transformer to dissipate heat generated by the coils. Placing the connection bar 130 above or below the transformer may

increase thermal dissipation of the high voltage coils, reduce warming during operation, and increase the rating of the transformer.

[0067] As mentioned, connection bar 130 may be used to form any desired connection including, for example, delta connections of any type (e.g., delta-wye 1, delta-wye 11, etc.), wye connections, single phase series or parallel connections, etc.

[0068] In some embodiments, external connector terminals 204a-c and/or connectors 206a-c may include plug-in bushings such as IEEE 386 connectors.

[0069] As mentioned, in some embodiments, connection bar 130 may be manufactured by casting with an epoxy resin or other insulator with a mold, under vacuum, including, for example, connection leads, connection nuts, plug-in bushings, a shielding system, openings for high voltage terminals, etc. In some embodiments, transformer coils may be manufactured by casting coils within an epoxy resin or other insulator with a mold, under vacuum, including windings and insulations, connection leads, connection nuts, a shielding system, taps, etc. Curing may include a thermal process, such as a thermal anneal. In some embodiments, assembly of a dry-type transformer may include placing high voltage terminals in openings of the connection bar; connecting high voltage terminals to electrical pathways in the connection bar (e.g., via conductive bridges, screws, washers, nuts, etc.); closing and sealing the connection bar openings; connecting (grounding) shields, and filling the openings with insulation (e.g., epoxy resin).

[0070] In one or embodiments described herein, through use of shielding, connection bar 130 and transformer housings 114a-c may be grounded. Further, connection bar 130 and transformer housings 114a-c may be submersible.

[0071] In some embodiments, high voltage terminals 124a-b, 126a-b and/or 128a-b may have lead conductors cast in insulation, such as a resin. In one or more embodiments, a thickness of the insulation surrounding high voltage terminals 124a-b, 126a-b and/or 128a-b may be largest near the coils, forming a conical shape. Other insulation shapes may be used.

[0072] In some embodiments, a method is provided that includes forming a dry-type transformer by (a) providing a plurality of high voltage coils, each including two high voltage terminals positioned at a top or bottom of the high voltage coil; (b) providing a connection bar including an electrically insulating body having a plurality of openings and an electrical connection pathway within the electrically insulating body; (c) positioning the connection bar so that each high voltage terminal of each high voltage coil is positioned within a respective opening of the plurality of openings in the electrically insulating body; and (d) coupling each high voltage terminal of each high voltage coil to the electrical connection pathway.

[0073] In some embodiments, a method is provided that includes forming a connection bar for connecting multiple high voltage coils of a dry-type transformer along a top or bottom of the transformer. The method includes (a) forming an electrically insulating body having a plurality of openings (b) forming an electrical connection pathway within the electrically insulating body, the electrical connection

pathway extending between the plurality of openings and configured to create a predetermined electrical connection between multiple high voltage coils of the transformer; (c) forming external connector terminals embedded within and extending from the electrically insulating body, the external connector terminals connected to the electrical connection pathway; and (d) forming a ground shield embedded within the electrically insulating body and configured to shield high voltage terminals of each high voltage coil of the transformer.

[0074] While the present disclosure is described primarily with regard to submersible dry-type transformers, it will be understood that the disclosed embodiments may also be employed with other dry-type transformers, such as dry-type transformers that operate at high voltage (e.g., 110 kV), dry-type transformers for wind farms, or other dry-type transformers. In some embodiments, a dry-type transformer having shielded coils, with grounded shielding, may employ a connector bar as described herein. Such dry-type transformers may or may not be submersible.

[0075] The foregoing description discloses only example embodiments. Modifications of the above-disclosed apparatus and methods which fall within the scope of this disclosure will be readily apparent to those of ordinary skill in the art. For example, although the examples discussed above are illustrated for power distribution systems, other embodiments in accordance with this disclosure can be implemented for other markets.

**CLAIMS**

What is claimed is:

1. A connection bar for connecting multiple high voltage coils of a dry-type transformer along a top or bottom of the dry-type transformer comprising:

an electrically insulating body sized to extend across high voltage terminals of multiple high voltage coils of the transformer, the electrically insulating body having a plurality of openings that extend into the electrically insulating body, each opening sized to receive at least one of the high voltage terminals of a respective one of the high voltage coils of the transformer;

an electrical connection pathway within the electrically insulating body, the electrical connection pathway extending between the plurality of openings and configured to create a predetermined electrical connection between multiple high voltage coils of the transformer;

external connector terminals embedded within and extending from the electrically insulating body, the external connector terminals connected to the electrical connection pathway; and

a ground shield embedded within the electrically insulating body and configured to shield high voltage terminals of each high voltage coil of the transformer.

2. The connection bar of claim 1 wherein the electrically insulating body includes at least three openings and is configured to receive the high voltage terminals of three high voltage coils of the transformer.

3. The connection bar of claim 1 wherein the electrical connection pathway is configured to form a delta connection between the high voltage coils of the transformer.

4. The connection bar of claim 1 wherein the electrical connection pathway is configured to form a wye connection between the high voltage coils of the transformer.

5. A dry-type transformer comprising:

a plurality of high voltage coils, each including two high voltage terminals positioned at a top or bottom of the high voltage coil;

a connection bar positioned to extend across the plurality of high voltage coils, the connection bar including:

an electrically insulating body sized to extend across the high voltage terminals of the high voltage coils of the transformer, the electrically insulating body having a plurality of openings that extend into the electrically insulating body, each opening sized to receive at least one of the high voltage terminals of a respective one of the high voltage coils of the transformer;

an electrical connection pathway within the electrically insulating body, the electrical connection pathway extending between the high voltage terminals within the plurality of openings so as to create a predetermined electrical connection between the multiple high voltage coils of the transformer; and

external connector terminals embedded within and extending from the electrically insulating body, the external connector terminals connected to the electrical connection pathway.

6. The transformer of claim 5 wherein the transformer includes three high voltage coils and three sets of high voltage terminals, each set including two high voltage terminals.

7. The transformer of claim 6 wherein the electrically insulating body includes at least three openings and is configured to receive the high voltage terminals of the three high voltage coils of the transformer.

8. The transformer of claim 5 wherein the electrical connection pathway is configured to form a delta connection between the high voltage coils of the transformer.

9. The transformer of claim 5 wherein the electrical connection pathway is configured to form a wye connection between the high voltage coils of the transformer.

10. The transformer of claim 5 further comprising a ground shield embedded within the electrically insulating body and configured to shield the high voltage terminals of each high voltage coil of the transformer.

11. The transformer of claim 5 wherein each opening of the electrically insulating body is filled with an insulating resin to electrically insulate the high voltage terminals within the openings.

12. The transformer of claim 11 wherein each opening of the electrically insulating body is covered with an electrically conductive cover and is grounded.

13. A method of forming a dry-type transformer comprising:

providing a plurality of high voltage coils, each including two high voltage terminals positioned at a top or bottom of the high voltage coil;

providing a connection bar including:

an electrically insulating body sized to extend across the high voltage terminals of the high voltage coils of the transformer, the electrically insulating body having a plurality of openings that extend into the electrically insulating body, each opening sized to receive at least one the high voltage terminals of a respective one of the high voltage coils of the transformer;

an electrical connection pathway within the electrically insulating body, the electrical connection pathway extending between the high voltage terminals within the plurality of openings so as to create a predetermined electrical connection between the multiple high voltage coils of the transformer; and

external connector terminals embedded within and extending from the electrically insulating body, the external connector terminals connected to the electrical connection pathway;

positioning the connection bar so that each high voltage terminal of each high voltage coil is positioned within a respective opening of the plurality of openings in the electrically insulating body; and

coupling each high voltage terminal of each high voltage coil to the electrical connection pathway.

14. The method of claim 13 wherein the transformer includes three high voltage coils and three sets of high voltage terminals, each set including two high voltage terminals.

15. The method of claim 14 wherein the electrically insulating body includes at least three openings and is configured to receive the high voltage terminals of the three high voltage coils of the transformer.

16. The method claim 13 wherein the electrical connection pathway is configured to form a delta connection between the high voltage coils of the transformer.

17. The method of claim 13 wherein the electrical connection pathway is configured to form a wye connection between the high voltage coils of the transformer.

18. The method claim 13 further employing a ground shield embedded within the electrically insulating body to shield the high voltage terminals of each high voltage coil of the transformer.

19. The method of claim 13 further comprising filling each opening of the electrically insulating body with an insulating resin to electrically insulate the high voltage terminals within the openings.

20. The method of claim 19 further comprising covering each opening of the electrically insulating body with an

electrically conductive cover and grounding each electrically conductive cover.

21. A method of forming a connection bar for connecting multiple high voltage coils of a dry-type transformer along a top or bottom of the transformer, the method comprising:

forming an electrically insulating body sized to extend across high voltage terminals of multiple high voltage coils of the transformer, the electrically insulating body having a plurality of openings that extend into the electrically insulating body, each opening sized to receive at least one of the high voltage terminals of a respective one of the high voltage coils of the transformer;

forming an electrical connection pathway within the electrically insulating body, the electrical connection pathway extending between the plurality of openings and configured to create a predetermined electrical connection between multiple high voltage coils of the transformer;

forming external connector terminals embedded within and extending from the electrically insulating body, the external connector terminals connected to the electrical connection pathway; and

forming a ground shield embedded within the electrically insulating body and configured to shield high voltage terminals of each high voltage coil of the transformer.

22. The method of claim 21 wherein the electrically insulating body includes at least three openings and is configured to receive the high voltage terminals of three high voltage coils of the transformer.

23. The method of claim 21 wherein the electrical connection pathway is configured to form a delta connection between the high voltage coils of the transformer.

24. The method of claim 21 wherein the electrical connection pathway is configured to form a wye connection between the high voltage coils of the transformer.

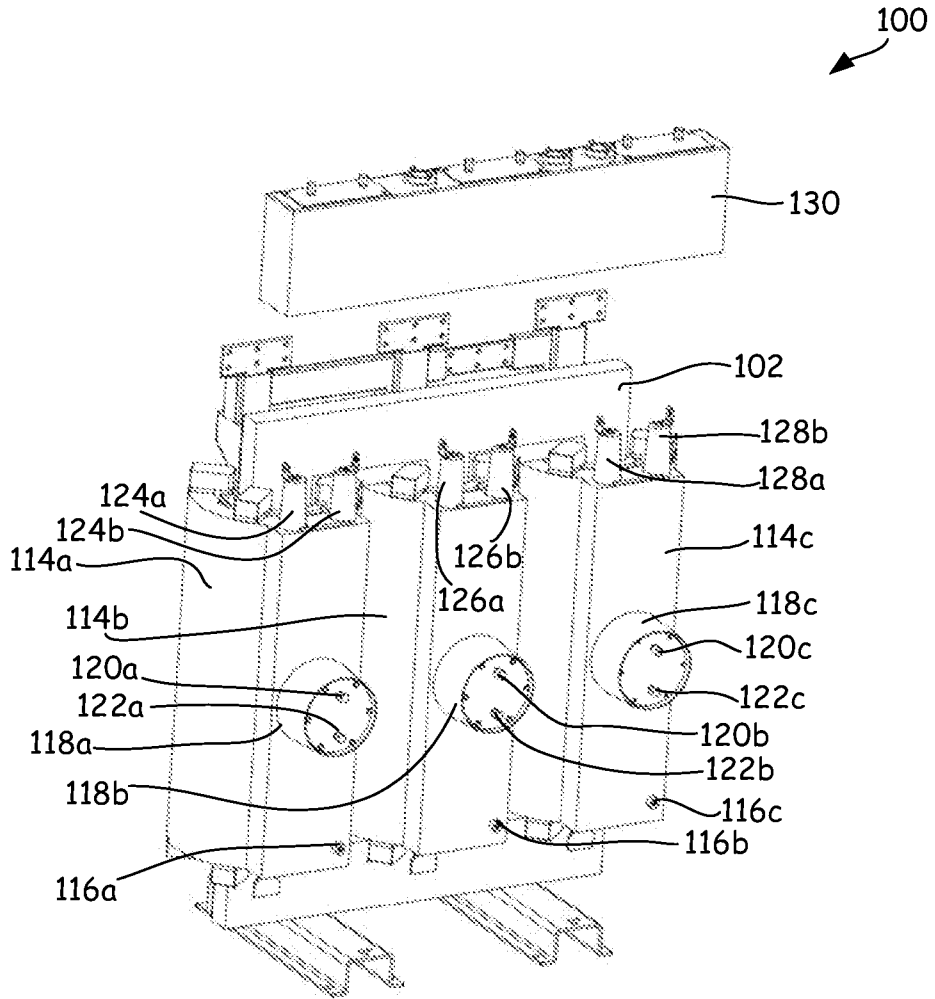

FIG. 1A

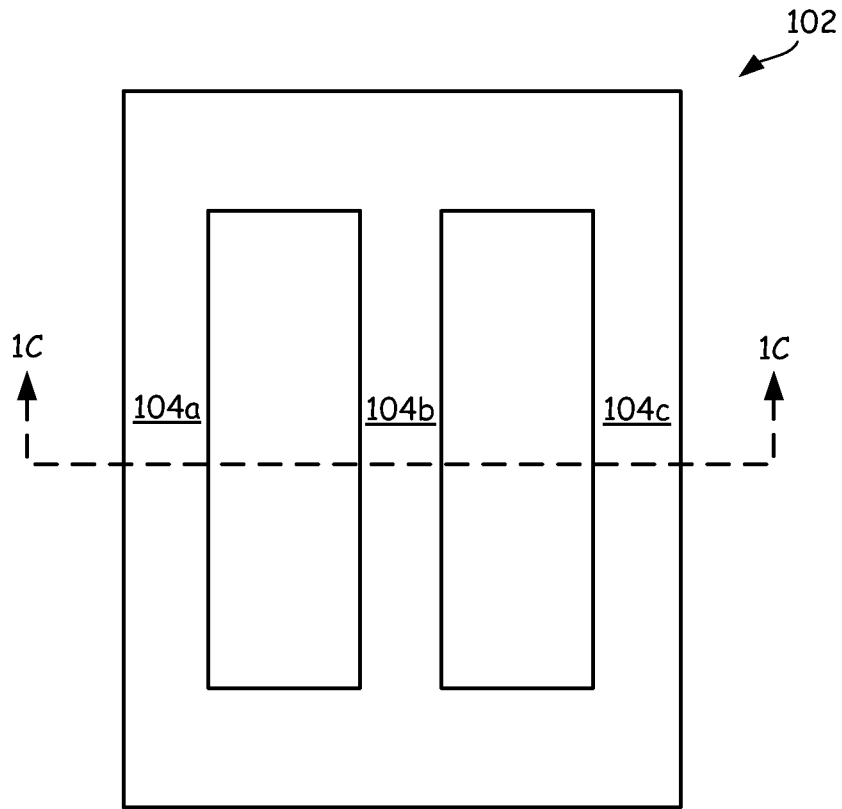

FIG. 1B

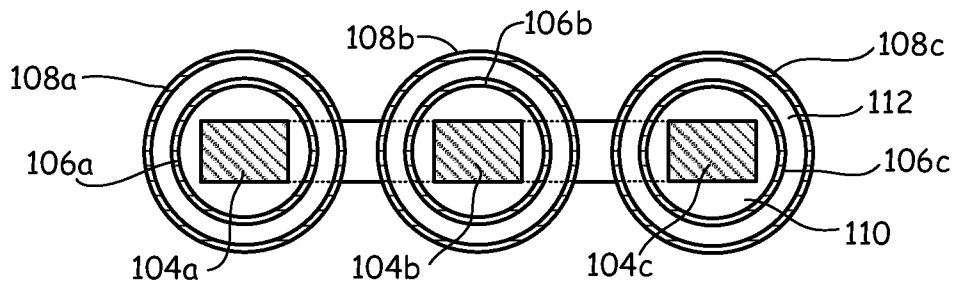
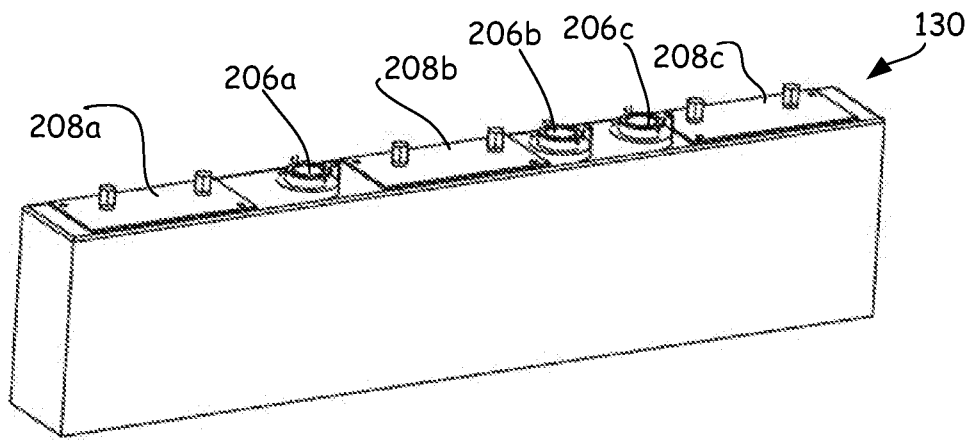
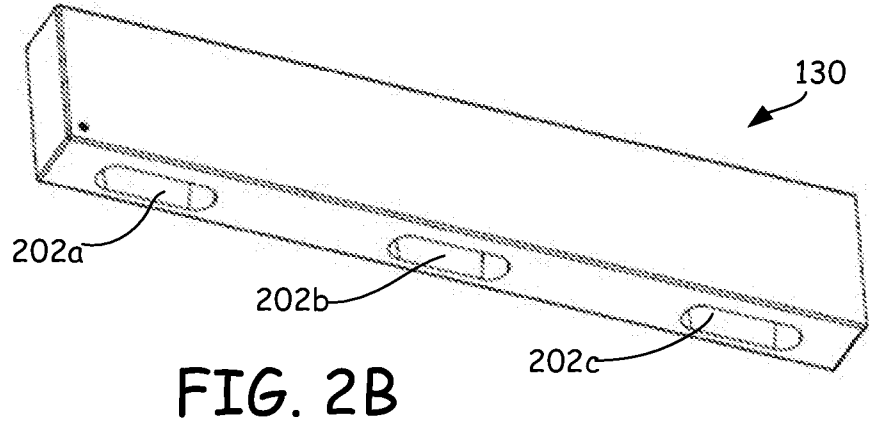
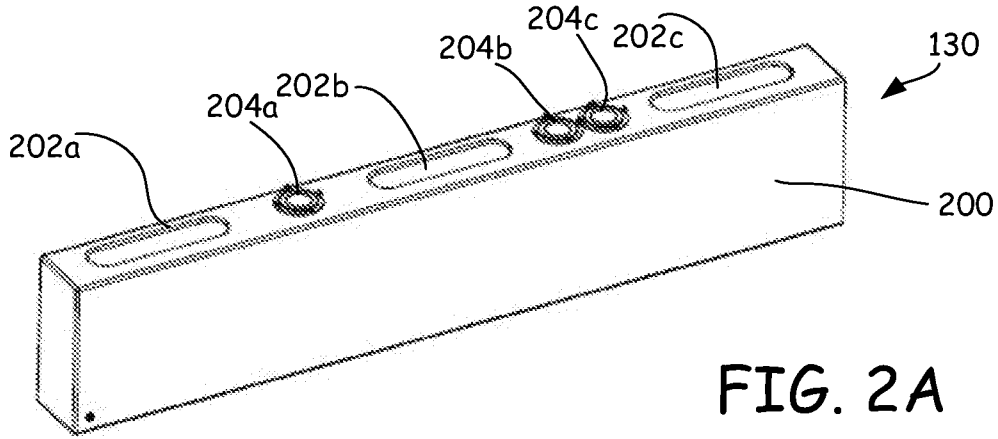

FIG. 1C



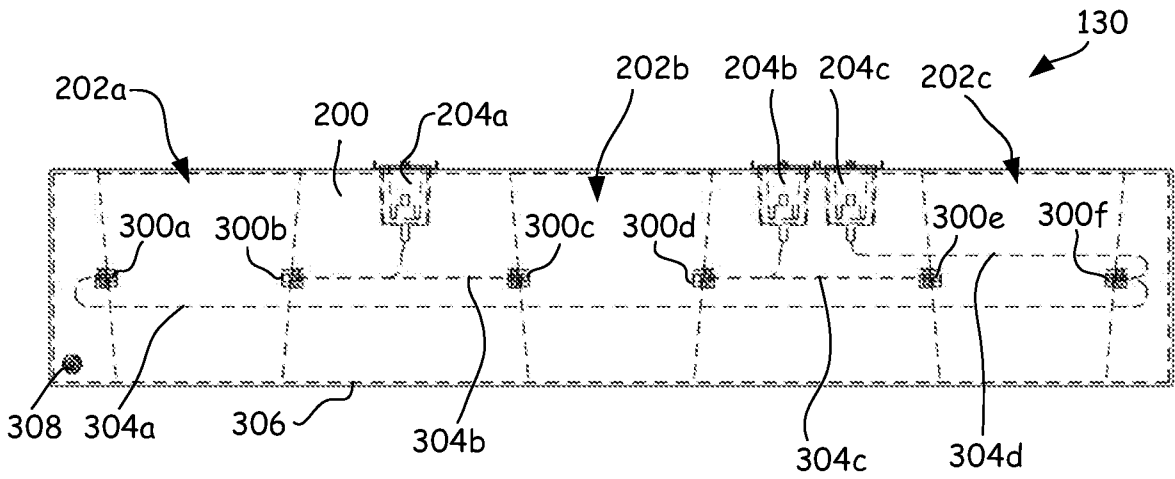

FIG. 3A

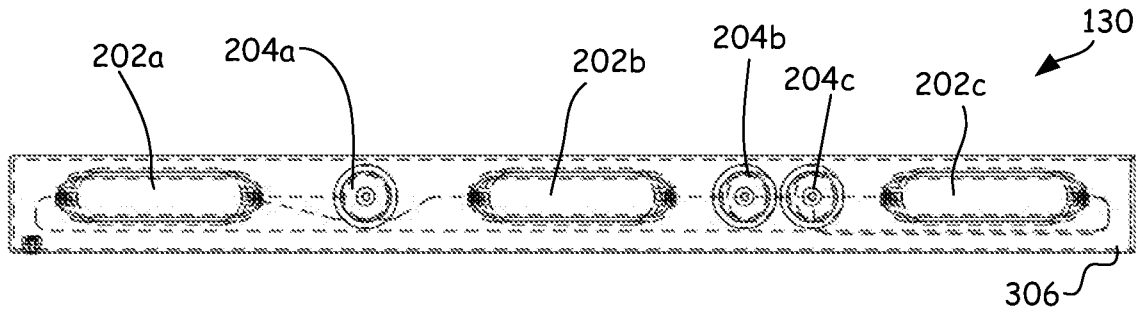

FIG. 3B

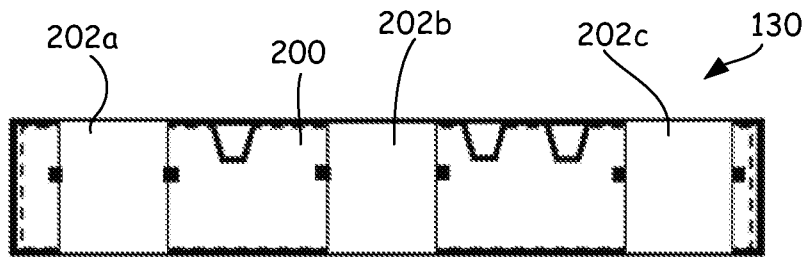

FIG. 3C

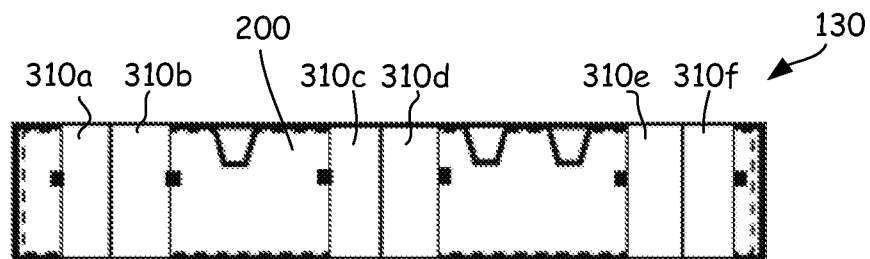

FIG. 3D

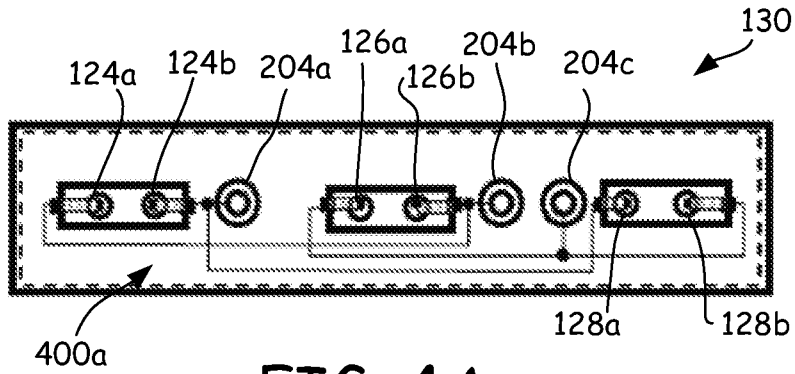

FIG. 4A

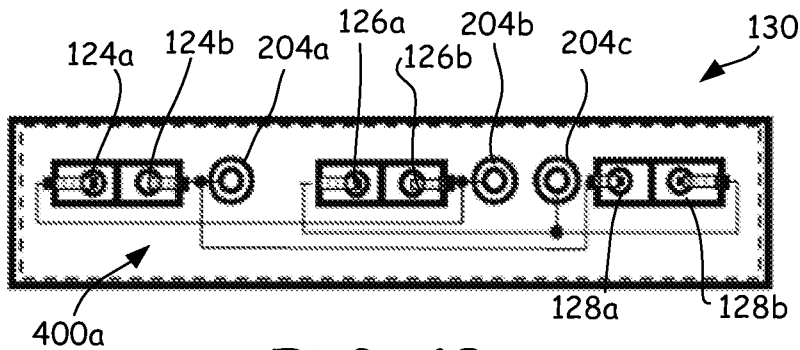

FIG. 4B

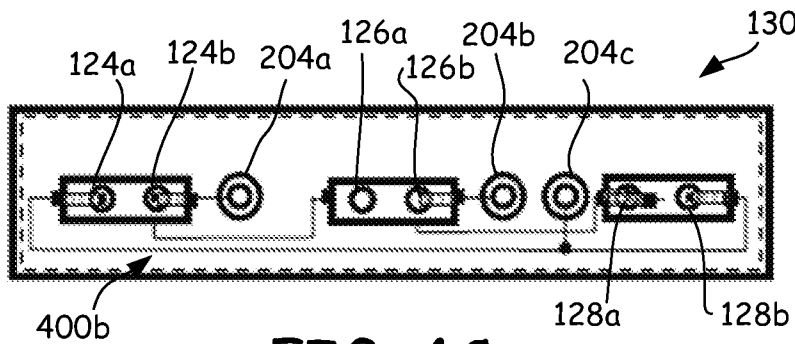

FIG. 4C

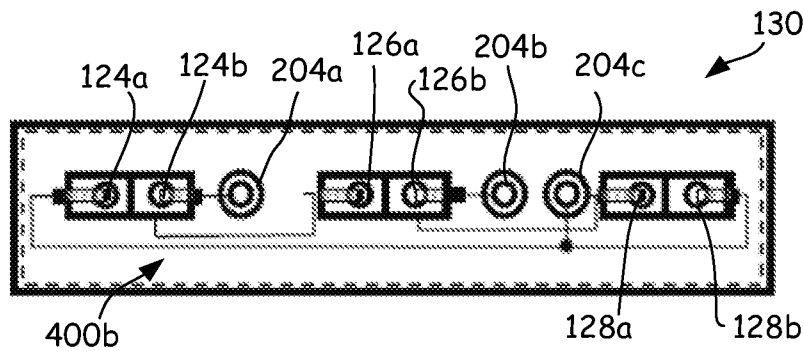

FIG. 4D

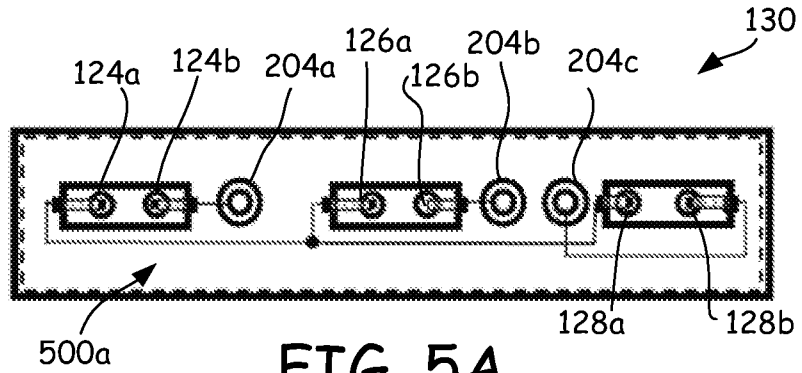

FIG. 5A

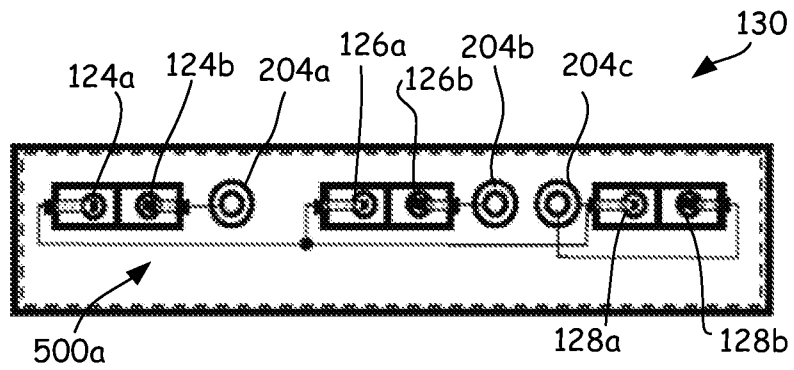

FIG. 5B

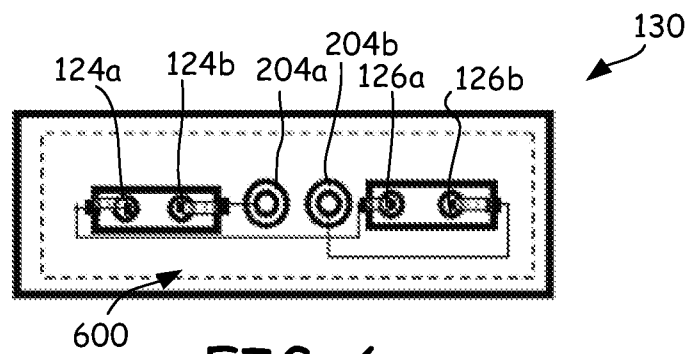

FIG. 6

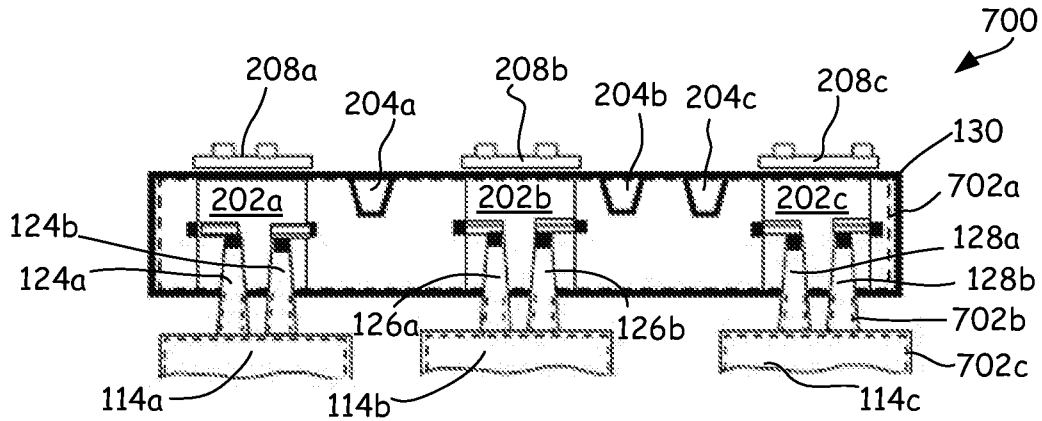

FIG. 7A

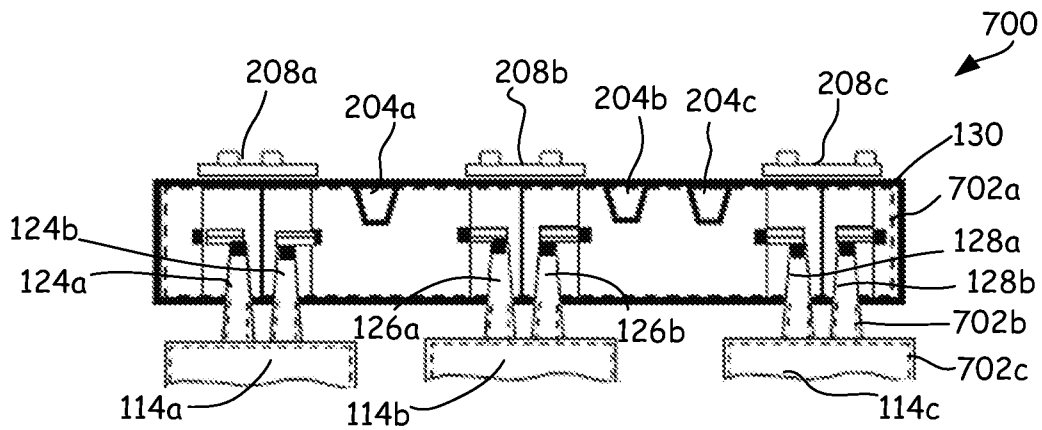

FIG. 7B

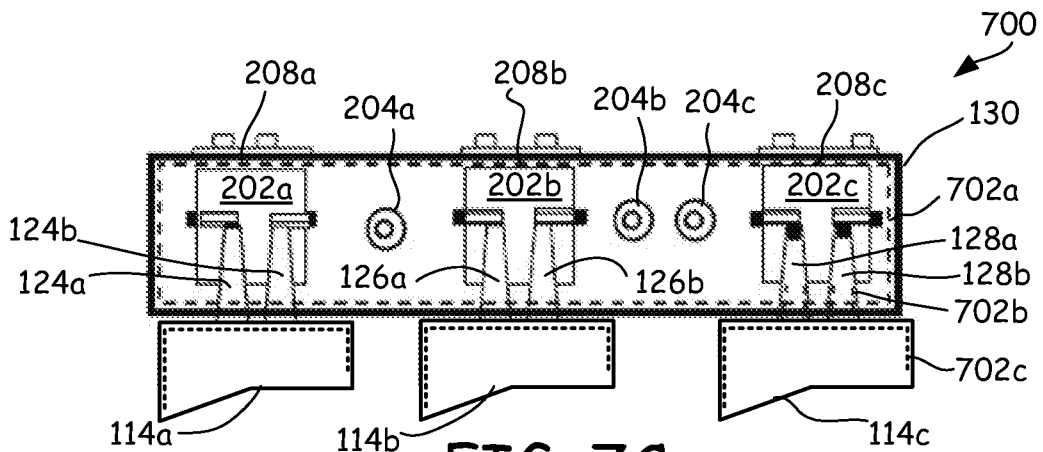

FIG. 7C

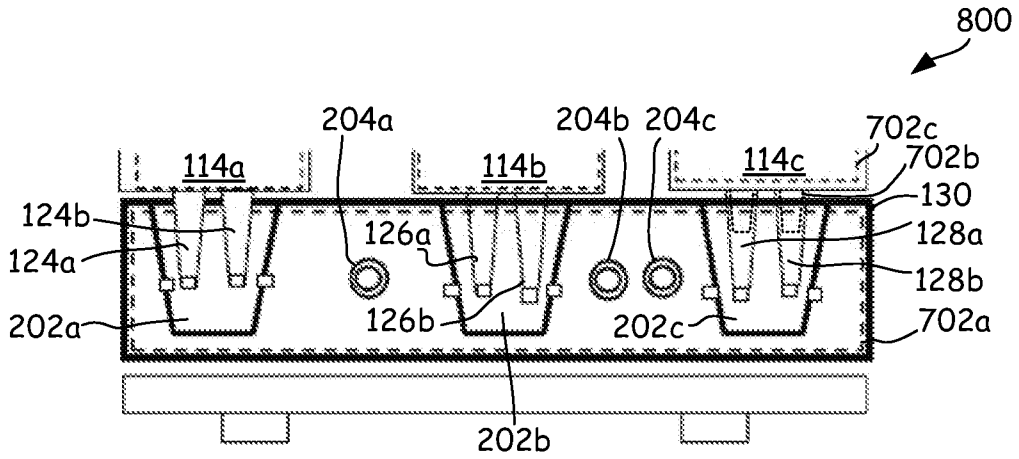

FIG. 8A

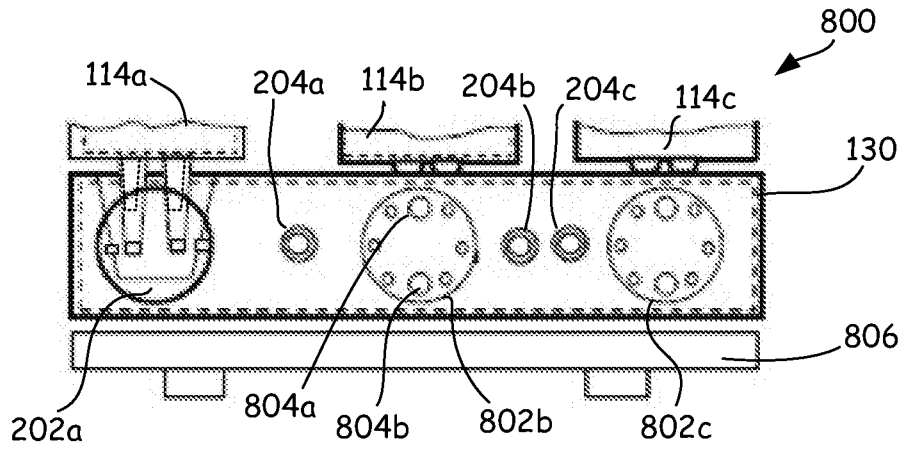

FIG. 8B

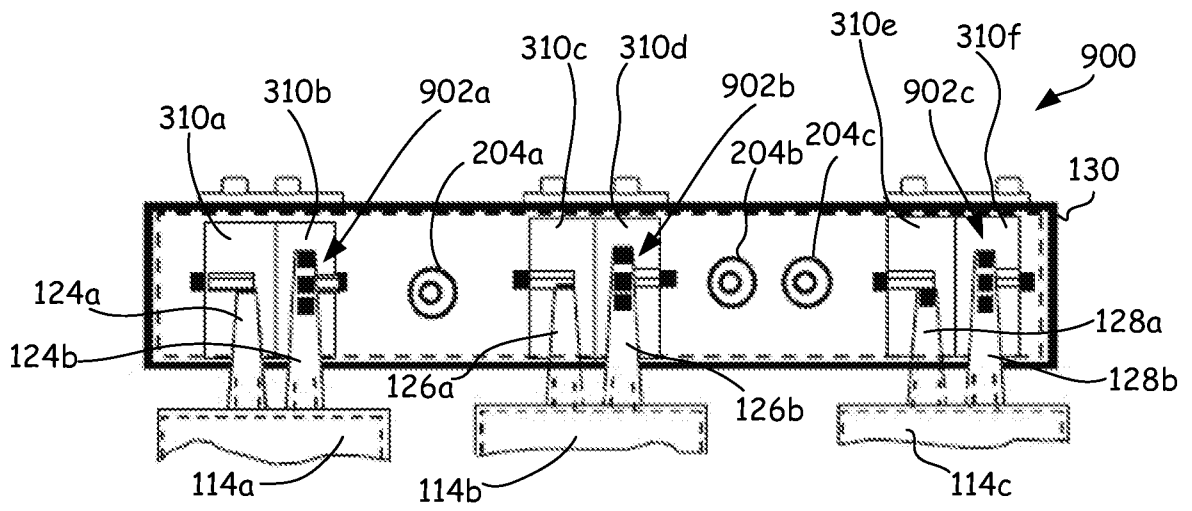

FIG. 9

100

