

M. K. Carpenter,

Elevator.

No. 90,230.

Patented May 18, 1869.

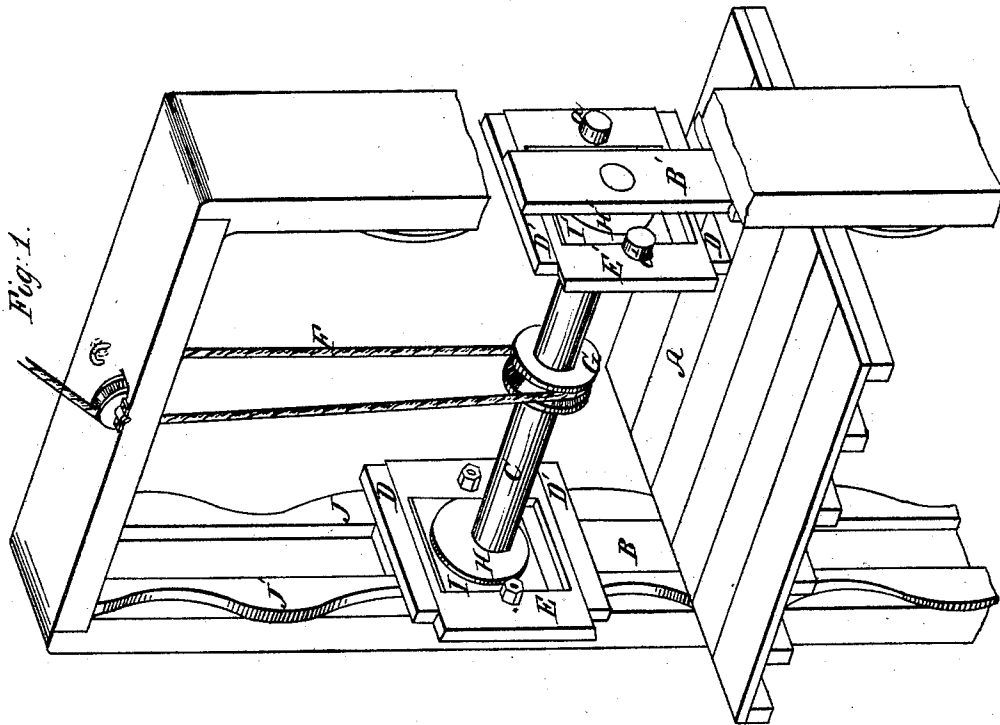
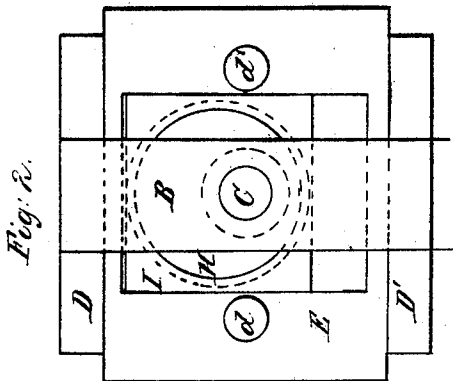

Witnesses;
George Brunous
Charles Pickles

Inventor;
Mitchael K. Carpenter
By Frank Miller and
attorney.

United States Patent Office.

MICHAEL K. CARPENTER, OF CINCINNATI, OHIO.

Letters Patent No. 90,286, dated May 18, 1869.

IMPROVEMENT IN HOISTING-MACHINES.

The Schedule referred to in these Letters Patent and making part of the same.

To all whom it may concern :

Be it known that I, MICHAEL K. CARPENTER, of Cincinnati, Hamilton county, State of Ohio, have invented a certain new and useful Improvement in Hoisting-Machines; and I do hereby declare the following to be a sufficiently full, clear, and exact description thereof, to enable one skilled in the art to which my invention appertains; to make and use it, reference being had to the accompanying drawings, making part of this specification.

My invention consists of certain devices, which, though they add but slight friction to the machine in ordinary operation, serve to effectually support the platform in a safe, positive manner, in the event of the breakage of the hoisting-rope or chain.

In the accompanying drawings—

Figure 1 is an isometric view of the parts of a hoisting-machine embodying my invention.

Figure 2 is a side view of a portion of the same.

The platform A has, firmly secured to it, the side bars B B', in which the shaft C is journaled.

Horizontal projections, D D', are secured to bars B B', and between these projections the slides E E' are fitted, to have a sliding reciprocating motion horizontally.

The platform A is operated by the rope, or chain F, which passes over the pulley G on shaft C.

The rope, or chain F is secured at one end, and wound and unwound, to raise and lower the platform, by suitable mechanism attached to the other end.

The shaft C has formed upon it, at each end, inside the journals, two cams, H H', which revolve in the circular apertures in the vertically-sliding plates I I'.

At the back of each of the slides E E' are two projecting pins, or studs, a a'.

As the platform is raised or lowered, the studs a a' follow closely against the curved ways J J', which are securely fastened to the upright timbers on the sides of the hatchway, in convenient lengths.

The platform A is confined to a straight vertical path by means of the bars B B', which slide between the straight inside edges of the ways J J'.

Operation.

It will be clearly understood, by reference to the accompanying drawings, and the foregoing description of parts, that, as the platform is raised or lowered by the chain F, the shaft C is revolved, the slides E E' reciprocated by cams H H', and the studs a a' follow the curved ways J J'. The weight of the platform rests wholly on the shaft C, and in the operation of the machine there is no friction of practical consequence attending the movements of cams and slides.

In the event of the breakage of the rope or chain, it is impossible for the platform to fall, inasmuch as it cannot move at all without a corresponding rotation of the shaft C, and it is practically impossible for the slides E E' to so act upon the cams H H' as to cause the shaft C to revolve.

As a slight modification in construction, the slides I I' may be omitted, and the cams H H' made of such size as to fit the inside vertical sides of the slides E E'. Another modification may consist in having the pulley G on a separate shaft, and gearing so as to run the shaft C faster, for greater safety.

I claim herein as new, and of my invention—

The cams H H', slides E E', a a', and curved ways J J', in the described connection, or relation to each other, in the herein-described hoisting-machine, and constructed and operating substantially in the manner and for the purpose specified.

In testimony of which invention, I hereunto set my hand.

M. K. CARPENTER.

Witnesses:

JEROME DU BOIS,
F. A. DOSSMANN.