



- (51) International Patent Classification:
B28D 1/18 (2006.01) E21C 35/183 (2006.01)
- (21) International Application Number:
PCT/US2015/027830
- (22) International Filing Date:
27 April 2015 (27.04.2015)
- (25) Filing Language: English
- (26) Publication Language: English
- (30) Priority Data:
14/266,437 30 April 2014 (30.04.2014) US
- (71) Applicant: US SYNTHETIC CORPORATION
[US/US]; 1260 South 1600 West, Orem, Utah 84058 (US).
- (72) Inventors: MIESS, David P.; 9639 North 6220 West,
Highland, Utah 84003 (US). GLEASON, Michael James;
584 East 600 South, Orem, Utah 84097 (US). WILDING,

Samuel Earl; 833 West 175 South, Springville, Utah 84663 (US). BURTON, Regan Leland; 2528 South Maverick Rd., Saratoga Springs, Utah 84045 (US). JONES, Paul Douglas; 387 N. Ama Fille Cir., Elk Ridge, Utah 84651 (US).

(74) Agents: SIMON, Marcus S. et al.; Kearns Building, 136 South Main Street, Suite 1000, Salt Lake City, Utah 84101-1685 (US).

(81) Designated States (unless otherwise indicated, for every kind of national protection available): AE, AG, AL, AM, AO, AT, AU, AZ, BA, BB, BG, BH, BN, BR, BW, BY, BZ, CA, CH, CL, CN, CO, CR, CU, CZ, DE, DK, DM, DO, DZ, EC, EE, EG, ES, FI, GB, GD, GE, GH, GM, GT, HN, HR, HU, ID, IL, IN, IR, IS, JP, KE, KG, KN, KP, KR, KZ, LA, LC, LK, LR, LS, LU, LY, MA, MD, ME, MG, MK, MN, MW, MX, MY, MZ, NA, NG, NI, NO, NZ, OM, PA, PE, PG, PH, PL, PT, QA, RO, RS, RU, RW, SA, SC,

[Continued on next page]

(54) Title: CUTTING TOOL ASSEMBLIES INCLUDING SUPERHARD WORKING SURFACES AND A ROTARY DRUM ASSEMBLY COMPRISING SUCH CUTTING TOOL ASSEMBLIES

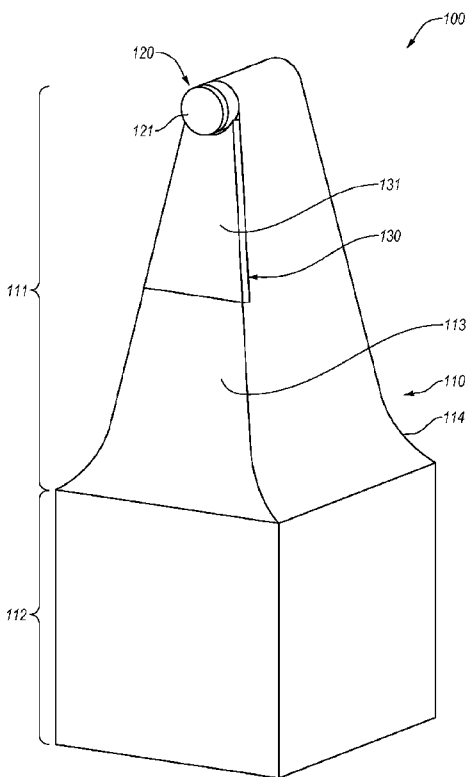

Fig. 1A

(57) Abstract: Embodiments of the invention are directed to cutting tool assemblies (100) that include one or more superhard working surfaces (121) and one or more shields (130) and to a rotary drum assembly (300) that comprises such cutting tool assemblies (100).

WO 2015/168034 A1



SD, SE, SG, SK, SL, SM, ST, SV, SY, TH, TJ, TM, TN,
TR, TT, TZ, UA, UG, US, UZ, VC, VN, ZA, ZM, ZW.

(84) Designated States (*unless otherwise indicated, for every kind of regional protection available*): ARIPO (BW, GH, GM, KE, LR, LS, MW, MZ, NA, RW, SD, SL, ST, SZ, TZ, UG, ZM, ZW), Eurasian (AM, AZ, BY, KG, KZ, RU, TJ, TM), European (AL, AT, BE, BG, CH, CY, CZ, DE,

DK, EE, ES, FI, FR, GB, GR, HR, HU, IE, IS, IT, LT, LU, LV, MC, MK, MT, NL, NO, PL, PT, RO, RS, SE, SI, SK, SM, TR), OAPI (BF, BJ, CF, CG, CI, CM, GA, GN, GQ, GW, KM, ML, MR, NE, SN, TD, TG).

Published:

— *with international search report (Art. 21(3))*

CUTTING TOOL ASSEMBLIES INCLUDING SUPERHARD WORKING SURFACES AND A ROTARY DRUM ASSEMBLY COMPRISING SUCH CUTTING TOOL ASSEMBLIES

CROSS-REFERENCE TO RELATED APPLICATIONS

5 [0001] This application claims priority to U.S. Patent Application No. 14/266,437 filed on 30 April 2014, the disclosure of which is incorporated herein, in its entirety, by this reference.

BACKGROUND

10 [0002] Milling and grinding machines are commonly used in various applications and industries, such as mining, asphalt and pavement removal and installation, and others. Such machines may remove material at desired locations. In some applications, material may be removed to facilitate repair or reconditioning of a surface. One example includes removing a portion or a layer of a paved road surface to facilitate repaving. In some instances, the removed material also may be valuable. For example, removed asphalt
15 may be reprocessed and reused. Similarly, in mining operations, removed material may include valuable or useful constituents.

[0003] Conventional machines include cutting tools that may cut or grind target material. Typically, such cutting tools are mounted on a rotating drum assembly and engage (*e.g.*, cut and/or grind) the target material as the drum assembly rotates. Failure of
20 the cutting tools may, in turn, lead to the failure of the drum assembly and/or interruptions in operation thereof.

[0004] Therefore, manufacturers and users of cutting tools continue to seek improved cutting tools to extend the useful life of drum assemblies and/or reduce or eliminate interruptions in operation thereof.

25 SUMMARY

[0005] Embodiments of the invention are directed to cutting tool assemblies, material-removing machines that include cutting tool assemblies, and methods of use and operation thereof. In some embodiments, the cutting tool assemblies described herein may be used in material-removing machines that may remove a target material, such as a
30 portion or a layer of a paved road surface. For example, a material-removing machine may include a rotary drum assembly, and the cutting tool assemblies may be mounted to or on the rotary drum assembly. Furthermore, as the material-removing machine rotates the rotary drum assembly, the cutting tool assemblies may engage and cut, grind, or

otherwise fail the target material, which may be subsequently removed (*e.g.*, by the rotary drum assembly of the material-removing machine).

[0006] In an embodiment, a cutting tool assembly is disclosed. The cutting tool assembly is configured for mounting on a rotary drum assembly and removing a target material. For example, the cutting tool assembly includes a support block having a mounting end and a working end. The mounting end is sized and configured to attach to the rotary drum assembly. In addition, the cutting tool assembly includes a cutting element secured to the working end of the support block. The cutting element has a working surface that includes a superhard material. Also, the cutting tool assembly includes a shield secured to the working end of the support block. The shield is sized and configured to protect at least a portion of the working end from abrasion and/or wear during operation of the cutting tool assembly.

[0007] Additional or alternative embodiments may include another cutting tool assembly for removing a target material. Such cutting tool assembly includes a support block that has a mounting end and a working end. The mounting end is sized and configured to attach to a material-removing machine. Moreover, the cutting tool assembly includes a shield secured to the working end of the support block and sized and configured to protect at least a portion of the working end from wear or abrasion. The cutting tool assembly also includes a cutting element secured to the shield and having a working surface that includes superhard material.

[0008] In an embodiment, a rotary drum assembly for removing a target material is disclosed. The rotary drum assembly includes a drum body having at least one of any of the disclosed cutting tool assemblies mounted thereto.

[0009] Features from any of the disclosed embodiments may be used in combination with one another, without limitation. In addition, other features and advantages of the present disclosure will become apparent to those of ordinary skill in the art through consideration of the following detailed description and the accompanying drawings.

BRIEF DESCRIPTION OF THE DRAWINGS

[0010] The drawings illustrate several embodiments, wherein identical reference numerals refer to identical or similar elements or features in different views or embodiments shown in the drawings.

[0011] **FIG. 1A** is an isometric view of a cutting tool assembly according to an embodiment of the invention;

- [0012] FIG. 1B is an isometric view of a cutting tool assembly according to an embodiment of the invention;
- [0013] FIG. 2A is a cross-sectional view of a shield according to an embodiment of the invention;
- 5 [0014] FIG. 2B is a cross-sectional view of a shield according to another embodiment of the invention;
- [0015] FIG. 3A is a partial cross-sectional view of a cutting tool assembly according to an embodiment of the invention;
- [0016] FIG. 3B is a partial cross-sectional view of a cutting tool assembly
10 according to another embodiment of the invention;
- [0017] FIG. 3C is a partial isometric view of a cutting tool assembly according to yet another embodiment of the invention;
- [0018] FIG. 3D is a cross-sectional view of a shield according to an embodiment of the invention;
- 15 [0019] FIG. 4A is an isometric view of a cutting tool assembly according to an embodiment of the invention;
- [0020] FIG. 4B is a partial cross-sectional view of a cutting tool assembly according to another embodiment of the invention;
- [0021] FIG. 4C is a partial isometric view of a cutting tool assembly according to
20 yet another embodiment of the invention;
- [0022] FIG. 4D is a partial isometric view of a cutting tool assembly according to still another embodiment of the invention;
- [0023] FIG. 5A is a partial cross-sectional view of a cutting tool assembly according to another embodiment of the invention;
- 25 [0024] FIG. 5B is a partial isometric view of a cutting tool assembly according to still yet one other embodiment of the invention;
- [0025] FIG. 5C is a partial cross-sectional view of the cutting tool assembly of FIG. 5B;
- [0026] FIG. 5D is an isometric view of a shield with an attached cutting element
30 according to an embodiment of the invention;
- [0027] FIG. 5E is a partial cross-sectional view of a shield attached to a support block according to an embodiment of the invention;
- [0028] FIG. 5F is a partial cross-sectional view of a shield attached to a support block according to another embodiment of the invention;

[0029] FIG. 6A is a partial isometric view of a cutting tool assembly according to an embodiment of the invention;

[0030] FIG. 6B is a partial isometric view of a cutting tool assembly according to another embodiment of the invention;

5 [0031] FIG. 7 is a partial isometric view of a cutting tool assembly according to yet another embodiment of the invention;

[0032] FIG. 8A is a front view of a cutting tool assembly according to an embodiment of the invention;

[0033] FIG. 8B is a side view of the cutting tool assembly of FIG. 8A;

10 [0034] FIG. 8C is a front view of a cutting tool assembly according to another embodiment of the invention;

[0035] FIG. 8D is a side view of the cutting tool assembly of FIG. 8C;

[0036] FIG. 8E is an isometric view of a cutting tool assembly according to an embodiment of the invention;

15 [0037] FIG. 8F is a front view of the cutting tool assembly of FIG. 8E;

[0038] FIG. 9A is a cross-sectional view of a cutting element according to an embodiment of the invention;

[0039] FIG. 9B is a cross-sectional view of a cutting element according to another embodiment of the invention;

20 [0040] FIG. 10A is an isometric view of a rotary drum assembly according to an embodiment of the invention; and

[0041] FIG. 10B is a side view of a material-removing machine according to an embodiment of the invention.

DETAILED DESCRIPTION

25 [0042] Embodiments of the invention are directed to cutting tool assemblies, material-removing machines that include cutting tool assemblies, and methods of use and operation thereof. In some embodiments, the cutting tool assemblies described herein may be used in material-removing machines that may remove target material, such as a portion or a layer of a paved road surface. For example, a material-removing machine
30 may include a rotary drum assembly, and the cutting tool assemblies may be mounted to or on the rotary drum assembly. Furthermore, as the material-removing machine rotates the rotary drum assembly, the cutting tool assemblies may engage and cut, grind, or otherwise fail the target material, which may be subsequently removed (*e.g.*, by the rotary drum assembly of the material-removing machine).

[0043] In an embodiment, the cutting tool assemblies may include one or more superhard working surfaces that may engage the target material. As used herein, “superhard material” includes materials exhibiting a hardness that is at least equal to the hardness of tungsten carbide (*i.e.*, a portion of or the entire working surface may have a hardness that exceeds the hardness of tungsten carbide). In any of the embodiments disclosed herein, the cutting tool assemblies and the cutting elements may include one or more superhard materials, such as polycrystalline diamond, polycrystalline cubic boron nitride, silicon carbide, tungsten carbide, or any combination of the foregoing superhard materials. For example, a cutting element may include a substrate and a superhard material bonded to the substrate, as described in further detail below. The superhard material may form or define the working surface.

[0044] The cutting tool assemblies may include a support block. For example, the working surface may be formed on or secured to the support block (*e.g.*, the working surface may be formed on a cutting element that is secured to the support block). In some embodiments, the cutting tool assemblies may include a shield configured to protect at least a portion of the support block from wear and/or abrasion that the support block may otherwise experience during operation. In some embodiments, the shield may include material that is harder and/or tougher (*e.g.*, more abrasion resistant) than the material from which the support block is made. Additionally or alternatively, the shield may be removably attached to the support block. A removable shield may be removed and/or replaced when suitable (*e.g.*, after a certain amount of wear of the shield), thereby maintaining appropriate integrity of the shield during operation and providing protection to the support block.

[0045] In some embodiments, the support block may be shaped, sized, or otherwise configured in a manner that may reduce wear thereof during operation and/or may improve flow and/or efficiency of cuttings or failed material relative to the support block. For example, the support block may be shaped in a manner that reduces drag and/or engagement thereof with the target material. Furthermore, in alternative or additional embodiments, the support block may be configured in a manner that reduces contact of the support block with the failed material (*e.g.*, as the failed material moves past the support block). As described above, in some embodiments, the failed material may be channeled away from the target material by the rotary drum assembly of the material-removing system, as described in further detail below. Moreover, the cutting tool assemblies may be secured to the rotary drum assembly and may come into contact

with the failed material, for instance, as the failed material is moved by the rotary drum assembly. In an embodiment, the support block of the cutting tool assembly may be shaped and sized in a manner that minimizes or reduces contact of the support block with the failed material during removal thereof, thereby extending useful life of the support
5 block and of the cutting tool assembly.

[0046] FIG. 1A illustrates an embodiment of a cutting tool assembly 100. For example, the cutting tool assembly 100 includes a support block 110 and a cutting element 120 secured to the support block 110. More specifically, in some embodiments, the support block 110 may include a working end 111 and a mounting end 112 (*i.e.*, the
10 working end 111 may be configured to engage and fail the target material). The cutting element 120 may be mounted or secure to the support block 110 at the working end 111 thereof.

[0047] As described below in further detail, the cutting element 120 may include a superhard working surface 121. The superhard working surface 121 may be sized and
15 configured to engage, cut, scrape, or otherwise cause the target material to fail. For example, the superhard working surface 121 may include a cutting edge that may define at least a portion of the perimeter of the superhard working surface 121. Particularly, the cutting edge may facilitate entry or penetration of the cutting element 120 into the target material and subsequent failing and/or removal thereof.

[0048] In some embodiments, the superhard working surface 121 may include a chamfered periphery. In other words, a chamfer may extend from at least a portion of the superhard working surface 121 to a peripheral surface of the cutting element 120. As
20 such, the chamfer may form two or more cutting edges (*e.g.*, a cutting edge formed at the interface between the working surface 121 and the chamfer and another cutting edge formed at the interface between the chamfer and the peripheral surface of the cutting
25 element 120).

[0049] In some embodiments, the superhard working surface 121 may include superhard material. As used herein, “superhard material” includes materials exhibiting a hardness that is at least equal to the hardness of tungsten carbide (*i.e.*, a portion or the
30 entire working surface may have a hardness that exceeds the hardness of tungsten carbide). In any of the embodiments disclosed herein, the cutting assemblies and the cutting elements may include one or more superhard materials, such as polycrystalline diamond, polycrystalline cubic boron nitride, silicon carbide, tungsten carbide, or any combination of the foregoing superhard materials. For example, a cutting element may

include a substrate and a superhard material bonded to the substrate, as described in further detail below.

[0050] In some embodiments, the superhard working surface 121 may be formed or defined by a superhard table that may be attached to a substrate. In an embodiment, 5 the substrate may be attached to the support block 110 and/or to shield (described below in further detail). Alternatively, the superhard table may be attached directly to the support block 110 and/or to the shield. Moreover, in some embodiments, the support block 110 and/or the shield may form the substrate (*e.g.*, the support block 110 and/or the shield may include suitable material for bonding the superhard table thereto, such as 10 tungsten carbide).

[0051] In an embodiment, the superhard table may comprise polycrystalline diamond and the substrate may comprise cobalt-cemented tungsten carbide. Furthermore, in any of the embodiments disclosed herein, the polycrystalline diamond table may be leached to at least partially remove or substantially completely remove a metal-solvent 15 catalyst (*e.g.*, cobalt, iron, nickel, or alloys thereof) that was used to initially sinter precursor diamond particles to form the polycrystalline diamond. In another embodiment, an infiltrant used to re-infiltrate a preformed leached polycrystalline diamond table may be leached or otherwise have a metallic infiltrant removed to a selected depth from a working surface. Moreover, in any of the embodiments disclosed 20 herein, the polycrystalline diamond may be un-leached and include a metal-solvent catalyst (*e.g.*, cobalt, iron, nickel, or alloys thereof) that was used to initially sinter the precursor diamond particles that form the polycrystalline diamond and/or an infiltrant used to re-infiltrate a preformed leached polycrystalline diamond table. Examples of methods for fabricating the superhard tables and superhard materials and/or structures 25 from which the superhard tables and elements may be made are disclosed in U.S. Patent Nos. 7,866,418; 7,998,573; 8,034,136; and 8,236,074; the disclosure of each of the foregoing patents is incorporated herein, in its entirety, by this reference.

[0052] The diamond particles that may be used to fabricate the superhard table in a high-pressure/high-temperature process (“HPHT”) may exhibit a larger size and at least 30 one relatively smaller size. As used herein, the phrases “relatively larger” and “relatively smaller” refer to particle sizes (by any suitable method) that differ by at least a factor of two (*e.g.*, 30 μm and 15 μm). According to various embodiments, the diamond particles may include a portion exhibiting a relatively larger size (*e.g.*, 70 μm , 60 μm , 50 μm , 40 μm , 30 μm , 20 μm , 15 μm , 12 μm , 10 μm , 8 μm) and another portion exhibiting at least

one relatively smaller size (*e.g.*, 15 μm , 12 μm , 10 μm , 8 μm , 6 μm , 5 μm , 4 μm , 3 μm , 2 μm , 1 μm , 0.5 μm , less than 0.5 μm , 0.1 μm , less than 0.1 μm). In an embodiment, the diamond particles may include a portion exhibiting a relatively larger size between about 10 μm and about 40 μm and another portion exhibiting a relatively smaller size between about 1 μm and 4 μm . In another embodiment, the diamond particles may include a portion exhibiting the relatively larger size between about 15 μm and about 50 μm and another portion exhibiting the relatively smaller size between about 5 μm and about 15 μm . In another embodiment, the relatively larger size diamond particles may have a ratio to the relatively smaller size diamond particles of at least 1.5. In some embodiments, the diamond particles may comprise three or more different sizes (*e.g.*, one relatively larger size and two or more relatively smaller sizes), without limitation. The resulting polycrystalline diamond formed from HPHT sintering the aforementioned diamond particles may also exhibit the same or similar diamond grain size distributions and/or sizes as the aforementioned diamond particle distributions and particle sizes. Additionally, in any of the embodiments disclosed herein, the superhard cutting elements may be free-standing (*e.g.*, substrateless) and/or formed from a polycrystalline diamond body that is at least partially or fully leached to remove a metal-solvent catalyst initially used to sinter the polycrystalline diamond body.

[0053] As noted above, the superhard table may be bonded to the substrate. For example, the superhard table comprising polycrystalline diamond may be at least partially leached and bonded to the substrate with an infiltrant exhibiting a selected viscosity, as described in U.S. Patent Application No. 13/275,372, entitled "Polycrystalline Diamond Compacts, Related Products, And Methods Of Manufacture," the entire disclosure of which is incorporated herein by this reference. In an embodiment, an at least partially leached polycrystalline diamond table may be fabricated by subjecting a plurality of diamond particles (*e.g.*, diamond particles having an average particle size between 0.5 μm to about 150 μm) to an HPHT sintering process in the presence of a catalyst, such as cobalt, nickel, iron, or an alloy of any of the preceding metals to facilitate intergrowth between the diamond particles and form a polycrystalline diamond table comprising bonded diamond grains defining interstitial regions having the catalyst disposed within at least a portion of the interstitial regions. The as-sintered polycrystalline diamond table may be leached by immersion in an acid or subjected to another suitable process to remove at least a portion of the catalyst from the interstitial regions of the polycrystalline diamond table, as described above. The at least partially leached polycrystalline diamond

table includes a plurality of interstitial regions that were previously occupied by a catalyst and form a network of at least partially interconnected pores. In an embodiment, the sintered diamond grains of the at least partially leached polycrystalline diamond table may exhibit an average grain size of about 20 μm or less. Subsequent to leaching the polycrystalline diamond table, the at least partially leached polycrystalline diamond table may be bonded to a substrate in an HPHT process via an infiltrant with a selected viscosity. For example, an infiltrant may be selected that exhibits a viscosity that is less than a viscosity typically exhibited by a cobalt cementing constituent of typical cobalt-cemented tungsten carbide substrates (*e.g.*, 8% cobalt-cemented tungsten carbide to 13% cobalt-cemented tungsten carbide).

[0054] Additionally or alternatively, the superhard table may be a polycrystalline diamond table that has a thermally-stable region, having at least one low-carbon-solubility material disposed interstitially between bonded diamond grains thereof, as further described in U.S. Patent Application No. 13/027,954, entitled "Polycrystalline Diamond Compact Including A Polycrystalline Diamond Table With A Thermally-Stable Region Having At Least One Low-Carbon-Solubility Material And Applications Therefor," the entire disclosure of which is incorporated herein by this reference. The low-carbon-solubility material may exhibit a melting temperature of about 1300 $^{\circ}\text{C}$ or less and a bulk modulus at 20 $^{\circ}\text{C}$ of less than about 150 GPa. The low-carbon-solubility, in combination with the high diamond-to-diamond bond density of the diamond grains, may enable the low-carbon-solubility material to be extruded between the diamond grains and out of the polycrystalline diamond table before causing the polycrystalline diamond table to fail during operations due to interstitial-stress-related fracture.

[0055] In some embodiments, the polycrystalline diamond, which may form the superhard table, may include bonded-together diamond grains having aluminum carbide disposed interstitially between the bonded-together diamond grains, as further described in U.S. Patent Application No. 13/100,388, entitled "Polycrystalline Diamond Compact Including A Polycrystalline Diamond Table Containing Aluminum Carbide Therein And Applications Therefor," the entire disclosure of which is incorporated herein by this reference.

[0056] In additional or alternative embodiments, the cutting tool assembly 100 may include a shield 130, which may be sized and configured to protect the support block 110 from abrasion, damage, wear, etc., during operation of the cutting tool assembly 100. In some embodiments, the shield 130 may be secured to the working end 111 of the

support block 110 below the cutting element 120. For example, the shield 130 may be fastened, brazed, or otherwise selectively (*e.g.*, removably) secured to the support block 110. Alternatively, the shield 130 may be non-removably secured to the support block 110 and/or may be integrated therewith.

5 [0057] In some embodiments, the shield 130 may include abrasion and wear resistant material. More specifically, material of the shield 130 may be more abrasion and/or wear resistant than the material of the support block 110. In some instances, the shield 130 may include material that is harder than the material of the support block 110. For example, the support block 110 may include steel, such as stainless steel or similar
10 material, which may have hardness of about 15 HRC to 65 HRC, while the shield 130 may have a hardness of cemented tungsten carbide or harder (*e.g.*, tungsten carbide, cubic boron nitride, diamond, and the like). In another example, the support block 110 may comprise steel (*e.g.*, annealed or tempered steel) and the shield 130 may comprise harder steel, such as heat-treated or hardened steel. In one or more embodiments, the support
15 block 110 may be manufactured from powdered material, such as powdered matrix materials (*e.g.*, by compressing such materials into a shape desired for the support block 110 and heating the compressed material in a manner that bonds the matrix together), as described in further detail in U.S. Patent Nos. 8,047,260; 4,484,644; 5,090,491; and 6,089,123. Disclosures of each of the above-referenced patents are incorporated herein in
20 their entireties by this reference. In an embodiment, the matrix or green body may be sintered by infiltrating a binder, such as copper, silver, alloys thereof, etc.

[0058] Furthermore, as noted above, the shield 130 may be removable and/or replaceable. As such, in some instances, the shield 130 also may be sacrificial. In other words, any suitable material for the shield 130 may be selected based on intended
25 replacement of the shield 130 (*e.g.*, the material for the shield 130 may be selected based on cost thereof). Consequently, in some embodiments, the shield 130 may include materials that have lower hardness and/or abrasion resistance than the material of the support block 110. Suitable material for the shield 130 may include rubber, plastic, etc. As the shield 130 wears (*e.g.*, beyond usable state), the shield 130 may be replaced with
30 another shield 130. Replacement of the shield 130 may prevent damage or wear of the support block 110. In any event, the shield 130 may protect the support block 110 from damage, thereby extending useful life thereof as well as of the cutting tool assembly 100.

[0059] As described above, in some embodiments, the shield 130 may be secured to the support block 110 at the working end 111 thereof. In one embodiment, the shield

130 may be brazed to the support block 110. In one embodiment, the shield 130 may be secured near the cutting element 120 and may protect or shield a portion of the cutting element 120 that secures the cutting element 120 to the support block 110. Likewise, the shield 130 may shield at least a portion of the working end 111 of the support block 110 that facilitates attachment of the cutting element 120 to the support block 110. For example, the support block 110 may include at least a partial pocket or recess that may secure the cutting element 120. The shield 130 may abut the cutting element 120 and/or such pocket or recess in the working end 111 of the support block 110 in a manner that protects attachment of the cutting element 120 to the support block 110.

10 [0060] It should be appreciated that in some instances, an unprotected recess or other location securing the cutting element 120 to the support block 110 may be exposed to abrasion and wear, which may result in loosening, dislodging, or detachment of the cutting element 120 from the support block 110. Accordingly, protecting at least near the location of the attachment of the cutting element 120 to the support block 110 may facilitate continuous attachment thereof during operation of the cutting tool assembly 100, thereby increasing the useful life of the cutting tool assembly 100.

[0061] Generally, the shield 130 may have any shape, size, and configuration suitable for protecting the support block 110 and/or the cutting element 120 of the cutting tool assembly 100, which may vary from one embodiment to the next. In some 20 embodiments, the shield 130 may have a substantially planar shielding face 131, which may generally face in the same direction as the superhard working surface 121 of the cutting element 120. For example, the shield 130 may be configured as a plate that may be attached to the support block 110. In additional or alternative embodiments, the shielding face of the shield 130 may have any suitable configurations and may be nonplanar, interrupted, formed from multiple segments, and the like. Moreover, the 25 shield 130 may protect other faces and/or areas of the support block 110 (*e.g.*, the shield may at least partially wrap around the working end 111 of the support block 110).

[0062] In an embodiment, the shielding face 131 of the shield 130 may be approximately flush or planar with one or more faces of the support block 110 (*e.g.*, the 30 shielding face 131 may be flush with a front face 113). Alternatively, however, the shielding face 131 of the shield 130 may protrude beyond one or more faces of the support block 110. For example, the shielding face 131 of the shield 130 may protrude beyond the front face 113 of the support block 110.

[0063] In some embodiments, the shield 130 may be shaped in a manner that accommodates close positioning of the shield 130 to the cutting element 120. For example, as described below in further detail, the cutting element 120 may have an approximately cylindrical shape. In some embodiments, to accommodate the cylindrical shape of the cutting element 120, the shield 130 may have a corresponding cutout or notch formed therein, which may approximate the exterior shape of the cutting element 120. Consequently, at least a portion of the cutting element 120 may be surrounded by or adjacent to the shield 130, which among other things may protect the connection or attachment between the cutting element 120 and support block 110.

10 [0064] In some embodiments, the working end 111 of the support block 110 may be tapered. For example, the working end 111 of the support block 110 may exhibit a generally pyramidal shape, a generally frustoconical shape, a generally conical shape, or any other generally tapered shape, having a wider portion thereof located near and/or attaching to the mounting end 112 of the support block 110. In an embodiment, the cutting element 120 may be secured to a narrower portion of the tapered working end 15 111. The taper of the working end 111 may reduce otherwise undesirable contact of the support block 110 with the target material, thereby reducing drag and wear of at least a portion of the support block 110 that moves through the target material.

[0065] In at least one embodiment, the support block 110 also may include a transition radius 114 that may extend between a tapered portion of the working end 111 and the mounting end 112. The radius 114 may produce a smooth transition between the peripheral surface of the mounting end 112 and a peripheral surface of the tapered portion of the working end 111. It should be appreciated, however, that in additional or alternative embodiments, the support block 110 may include any number of suitable shapes that may facilitate attachment of the cutting element 120 as well as engagement of the cutting element 120 with the target material.

[0066] While the cutting tool assembly 100 is described above as including the cutting element 120 that has an approximately cylindrical shape, it should be appreciated that the cutting element may have any number of suitable shapes, which may be configured to engage, fail, and remove the target material, and which may include any number of cutting edges and/or working surfaces thereon. **FIG. 1B**, for example, illustrates a cutting tool assembly 100a that includes a cuboid cutting element 120a secured to a support block 110a. Except as otherwise described herein, the cutting tool assembly 100a and its materials, elements, or components may be similar to or the same

as cutting tool assembly 100 (**FIG. 1A**) and its respective materials, elements and components. For example, the cutting tool assembly 100a may include a shield 130a secured to the support block 110a, which may be similar to or the same as the shield 130 of the cutting tool assembly 100 (**FIG. 1A**).

5 **[0067]** Any of the cutting tool assemblies described herein may include one or more cutting elements, each of which may have any suitable shape and size. Suitable shapes for a cutting element include but are not limited to arcuate, oval, and polygonal. Moreover, the cutting tool assembly may include any number of cutting elements secured to a support block, and the cutting elements may have any number of suitable
10 orientations, which in some instances may facilitate indexing of the cutting tool assembly. In other words, as one or more of the cutting elements of the cutting tool assembly wear and/or become unusable, the cutting tool assembly may be indexed or reoriented (*e.g.*, rotated) in a manner that provides another cutting element for engagement with the target material.

15 **[0068]** As described above, the shield may have any number of suitable shapes and may connect or attach to the support block in any number of suitable ways. **FIG. 2A** illustrates one embodiment of a shield 130' that has a plate-like configuration. More specifically, the shield 130' includes an approximately planar shielding face 131' that may be aligned with a face of a support block. Moreover, the shield 130' includes a
20 mounting post 132', which may be secured within a recess in a support block. For example, the support block may include a recess sized and/or shaped to correspond with the mounting post 132'. Particularly, in an embodiment, the mounting post 132' may be press-fitted, welded, soldered, brazed, combinations thereof, or otherwise secured within a recess (*e.g.*, in a manner that secures the shield 130') to the support block.

25 **[0069]** In some embodiments, the shield may be fastened to the support block. **FIG. 2B** illustrates one example of a shield 130'' that is configured for attachment to the support block with one or more threaded fasteners. Specifically, the shield 130'' may include a threaded hole 132'', which may accept a threaded shaft such as a screw or bolt that may secure the shield 130'' to the support block. It should be appreciated, however,
30 that in additional or alternative embodiments, the shield 130'' may include a threaded male member that may pass into or through the support block and may be fastened thereto. Furthermore, the shield 130'' may be used in combination with other methods of attachment and/or attachment elements or structures, which may secure the shield 130'' to one or more portions of the cutting tool assembly (*e.g.*, to the support block).

[0070] For example, the support block may include a through hole or opening and the threaded male member may pass through such opening and may be secured to the support block with one or more nuts. In some instances, the support block may include a threaded hole and the threaded male member of the shield may be screwed into the threaded hole in the support block. In any event, the shield may be fastened to the support block with any number of suitable fasteners that may allow removal and/or replacement of the shield, as described above.

[0071] Also, the location and/or orientation of the shield on the support block may be achieved in any number of suitable ways. Moreover, in addition to or in lieu of fastening the shield to the support block, the shield may be secured by at least a portion of the support block. For example, as shown in **FIG. 3A**, a cutting tool assembly 100b may have a support block 110b that includes a pocket 115b that may secure shield 130b therein. For example, the pocket 115b may orient and/or position the shield 130b relative to the support block 110b. Except as otherwise described herein, the cutting tool assembly 100b and its materials, elements, or components may be similar to or the same as any of the cutting tool assemblies 100, 100a (**FIGS. 1A-1B**) and their respective materials, elements and components. For example, the shield 130b may be similar to or the same as any of the shields 130, 130a (**FIGS. 1A-1B**).

[0072] In some embodiments, the pocket 115b may at least partially secure the shield 130b to the support block 110b. For example, the pocket 115b may include an undercutting portion, such as an angled side 116b. In an embodiment, the angled side 116b may form an acute angle with a back side 117b of the pocket 115b. Likewise, the shield 130b may have a corresponding tapered or beveled side that may contact the angled side 116b of the pocket 115b. As such, the angled side 116b may restrain the shield 130b from lateral movement (*e.g.*, outward, away from the back side 117b).

[0073] In an embodiment, the pocket 115b may be defined by two opposing angled sides such as the angled side 116b and in angled side 118b. For example, the angled side 118b may form an obtuse angle relative to the backside 117b of the pocket 115b. Accordingly, the shield 130b may be inserted into the pocket 115b by sliding along the corresponding angled sides 116b, 118b. Furthermore, in some instances, the angled side 116b may be approximately parallel to the angled side 118b.

[0074] In an embodiment, the pocket 115b may be a partially open pocket. For example, the pocket 115b may be defined only by the backside 117b and opposing angled sides 116b, 118b. In other words, the pocket 115b may have open sides generally

orthogonal to the opposing angled sides 116b, 118b. Thus, without additional restraint, the shield 130b may be unrestrained from movement within the pocket 115b along directions generally parallel to the opposing angled sides 116b, 118b and along the back side 117b. In alternative or additional embodiments, however, the pocket may be enclosed by three, four, or any suitable number of sides, which may restrain the shield 130b from movement within the pocket. In some embodiments, the support block may be formed around the shield, so as to mechanically lock the shield and/or bond the shield to the support block.

[0075] Also, as mentioned above, the shield 130b may be secured to the cutting tool assembly 100b with one or more fasteners, such as a threaded fastener 140b. For example, the support block 110b may include an opening 119b that may allow the threaded fastener 140b to pass therethrough. Hence, the threaded fastener 140b may pass into the pocket 115b and may be threaded into the shield 130b, thereby securing the shield 130b to the support block 110b and/or within the pocket 115b.

[0076] The cutting tool assembly 100b also may include a cutting element 120b secured to the support block 110b. In at least one embodiment, the cutting element 120b may have a superhard working surface 121b. For example, the cutting element 120b may include a superhard table 122b that may be bonded or otherwise secured to a substrate 123b. Similar to the cutting tool assembly 100 (**FIG. 1A**), the superhard working surface 121b and/or the cutting edge forming the perimeter thereof may engage and fail the target material. In some instances, the superhard working surface 121b may be substantially planar. In some embodiments superhard working surface 121b also may include a chamfer or radius that at least partially extends about or surrounds the superhard working surface 121b.

[0077] In an embodiment, the superhard working surface 121b may be oriented at a nonparallel angle relative to a longitudinal centerline 10b. For example, the plane in which the superhard working surface 121b lies may form an acute angle with the longitudinal centerline 10b, such as an acute negative angle 160b. Moreover, as described below in more detail, the cutting tool assembly 100b may attach to a rotary drum assembly in a manner that the longitudinal centerline 10b is approximately aligned with the center of rotation of the rotary drum assembly. In alternative embodiment, the longitudinal centerline 10b may be misaligned with the center of rotation of the rotary drum assembly. In any event, in an embodiment, the cutting tool assembly 100b may be secured to the rotary drum assembly in a manner that the superhard working surface 121b

has a positive rake angle (*i.e.*, measured counterclockwise from longitudinal centerline 10b). It should be appreciated, however, that this disclosure is not so limited. In some instances, the superhard working surface 121b may have a negative rake angle (*i.e.*, measured clockwise from longitudinal centerline 10b).

5 [0078] As described above, the shield and the corresponding pocket may have any number of suitable configurations and sizes, which may vary from one embodiment to the next. **FIG. 3B** illustrates a cutting tool assembly 100c that includes a pocket 115c, which secures a shield 130c to the support block 110c. More specifically, the pocket 115c may include opposing angled sides 116c, 118c which may form acute angles relative to a
10 backside 117c. In some examples, the acute angles formed between the angled sides 116c, 118c and the backside 117c may be approximately the same. Alternatively, the respective angles formed between the backside 117c and the angled sides 116c, 118c may be different from each other. Except as otherwise described herein, the cutting tool assembly 100c and its materials, elements, or components may be similar to or the same
15 as any of the cutting tool assemblies 100, 100a, 100b (**FIGS. 1A-1B, 3A**) and their respective materials, elements and components.

[0079] The shield 130c may have corresponding angled or beveled sides that may at least partially contact one or more of the angled sides 116c, 118c of the pocket 115c. The angled sides 116c, 118c of the pocket 115c may cooperate with the corresponding
20 angled sides of the shield 130c and may restrain movement of the shield 130c within the pocket 115c. In particular, angled sides 116c, 118c may prevent or limit movement of the shield 130c out of the pocket 115c (*e.g.*, in a direction away from the back side 117c). In some examples, the pocket 115c may have at least one open side that may allow the shield 130c to slide into the pocket 115c (*e.g.*, along the angled sides 116c, 118c).

25 [0080] It may also be desirable to provide a shield that may be quickly and/or easily removed and replaced. For example, **FIG. 3C** illustrates a cutting tool assembly 100d that includes a removable shield 130d secured to a support block 110d (*e.g.*, removable shield 130d may elastically deform around support block 110d). Except as otherwise described herein, the cutting tool assembly 100d and its materials, elements, or
30 components may be similar to or the same as any of the cutting tool assemblies 100, 100a, 100b, 100c (**FIGS. 1A-1B, 3A-3B**) and their respective materials, elements and components. For example, the cutting tool assembly 100d may include a cutting element 120d secured to the support block 110d in a manner similar to the cutting element 120 is secured to the support block 110 (**FIG. 1A**).

[0081] In some embodiments, the shield 130d may at least partially wrap around or cover the support block 110d. For example, the shield 130d may cover two or three sides of the support block 110d. As such, the shield 130d may protect multiple sides of the support block 110d, thereby extending the useful life of the cutting tool assembly
5 100d. Additionally or alternatively, the shield may cover all of the sides of the support block 110d (*e.g.*, wrapping all four sides of the support block 110d).

[0082] Furthermore, as noted above, the shield 130d may snap or mechanically lock about the support block 110d. As the shield 130d wears by a certain amount (*e.g.*, beyond a useful state), the shield 130d may be removed from the support block 110d and
10 replaced. While the particular shape and size of the shield 130d may vary from one embodiment to the next, it should be appreciated that, generally, the shield 130d may fit snugly about the support block 110d. Hence, the shape and size of the internal portion of the shield 130d may approximate the shape and size of at least a portion of the peripheral surface of the support block 110d.

[0083] **FIG. 3D** illustrates one embodiment of the shield 130d. More specifically, the shield 130d may have tapered walls that form shielding faces 131d. For example, the shield 130d may include tapered walls 132d that may form the inner and outer peripheral surfaces of the shield 130d. The inner peripheral surface of the shield 130d may approximate the outer peripheral surface of the support block that secures the shield 130d.
15 In an embodiment, the inner peripheral surface may correspond with the angled walls of the support block. Embodiments also may include inner peripheral surface shaped and sized to at least partially wrap around support blocks of other various shapes and sizes.

[0084] The shield 130d also may include snap-on features that may secure the shield 130d to the support block. For example, the shield 130d may include snap-on
25 features 133d that may extend from opposing portions of the walls shielding face 131d. The shield 130d may include flexible and resilient material that may allow the snap-on features 133d to be deflected away from and retracted toward their original positions. Consequently, the walls 132d and/or the snap-on features 133d may be moved outward such that the inside of the shield 130d may accept a corresponding portion of the support
30 block. After the support block has been inserted into the shield 130d (or the shield 130d placed about the support block), the walls 132d and/or the snap-on features 133d may retract toward their original positions, thereby securing the shield 130d to the support block.

[0085] Conversely, embodiments also may include a shield that is permanently secured or attached to the support block. For example, **FIG. 4A** illustrates a cutting tool assembly 100e that includes a shield 130e permanently secured to a support block 110e. Except as otherwise described herein, the cutting tool assembly 100e and its materials, elements, or components may be similar to or the same as any of the cutting tool assemblies 100, 100a, 100b, 100c, 100d (**FIGS. 1A-1B, 3A-3C**) and their respective materials, elements and components.

[0086] In an embodiment, the shield 130e may include one or more of hardfacing, a coating, or plating that may at least partially surround the support block 110e. For example, the hardfacing may be a suitable wear resistant cobalt alloy (*e.g.*, a cobalt-chromium alloy). As another example, the hardfacing may be a commercially available CVD tungsten carbide layer (currently marketed under the trademark **HARDIDE®**), which is currently available from Hardide Layers Inc. of Houston, Texas. For example, the tungsten carbide layer may be formed by physical vapor deposition (“PVD”), variants of PVD, high-velocity oxygen fuel (“HVOF”) thermal spray processes, welding process, flame-spraying process, or any other suitable process, without limitation. The shield 130e may be located on at least a portion of at least one side of a working end 111e of the support block 110e. In at least one embodiment, the shield 130e may be located on portions of all of the sides of the working end 111e. In any event, the shield 130e may protect the underlying material of the support block 110e against wear and abrasion, thereby extending useful life thereof.

[0087] It should be appreciated that hardfacing or other coating may be included on any support block described herein, including support blocks that secure one or more other shields. **FIG. 4B** illustrates a cutting tool assembly 100f that includes a support block 110f with shields 130f, 131f protecting at least a portion of a working end 111f of the support block 110f. Except as otherwise described herein, the cutting tool assembly 100f and its materials, elements, or components may be similar to or the same as any of the cutting tool assemblies 100, 100a, 100b, 100c, 100d, 100e (**FIGS. 1A-1B, 3A-3C, 4A**) and their respective materials, elements and components. For example, the support block 110f may be similar to or the same as the support block 110b (**FIG. 3A**).

[0088] Moreover, in at least one embodiment, the hardfacing or coating may cover the uppermost portion or the top of the support block 110f, thereby forming the shields 130f, 131f. Also, similar to the cutting tool assembly 100b (**FIG. 3A**) the support block 110f may include a cutting element 120f secured to the support block 110f. As

described above, in some examples, the cutting element 120f may include a chamfer 122f that at least partially circumscribes a superhard working surface 121f.

[0089] Furthermore, the cutting element 120f may be secured in a pocket or recess 112f. For example, the recess 112f may set the particular location and/or orientation of the cutting element 120f relative to the support block 110f. Also, in an embodiment, the shields 130f, 131f may at least partially surround and protect the recess 112f, thereby protecting the attachment of the cutting element 120f with the support block 110f during operation of the cutting tool assembly 100f. Moreover, one or more of the shields 130f, 131f may extend over or at least partially cover a substrate 123f of the cutting element 120f. Additionally or alternatively, the cutting tool assembly 100f may include one or more gaps between respective shields 130f, 131f and the cutting element 120f (*e.g.*, between the respective shields 130f, 131f and the substrate 123f of the cutting element 120f).

[0090] While in some embodiments the support block may have a pyramid like or trapezoidal shape, this disclosure is not so limited; the support block may have any number of suitable shapes. For example, **FIG. 4C** illustrates a cutting tool assembly 100g that includes a support block 110g a portion of which has an approximately conical shape. Except as otherwise described herein, the cutting tool assembly 100g and its materials, elements, or components may be similar to or the same as any of the cutting tool assemblies 100, 100a, 100b, 100c, 100d, 100e, 100f (**FIGS. 1A-1B, 3A-3C, 4A-4B**) and their respective materials, elements and components. In an embodiment, a working end 111g of the support block 110g may have an approximately conical shape. Moreover, the approximate cone of the working end 111g may include an approximately spherical apex or tip 112g.

[0091] In some embodiments, the cutting tool assembly 100g may include a shield 130g that may at least partially wrap around the working end 111g. For example, the shield 130g may include hardfacing, coating, and the like, which may be bonded or otherwise secured or integrated with the support block 110g. Moreover, the cutting tool assembly 100g may include a cutting element 120g secured to the support block 110g. In particular, in at least one embodiment, the shield 130g may surround a portion of the working end 111g of the support block 110g (*e.g.*, the shield 130g may completely surround a portion of the support block 110g adjacent to or surrounding the cutting element 120g).

[0092] In additional or alternative embodiments, the shield may include multiple elements or components secured to or integrated with the support block. **FIG. 4D** illustrates a cutting tool assembly 100h that includes multiple shield elements 131h, which together form a shield 130h. Except as otherwise described herein, the cutting tool assembly 100h and its materials, elements, or components may be similar to or the same as any of the cutting tool assemblies 100, 100a, 100b, 100c, 100d, 100e, 100f, 100g (**FIGS. 1A-1B, 3A-3C, 4A-4C**) and their respective materials, elements and components.

[0093] The shield elements 131h may be secured to the support block 110h in any number of suitable ways including, but not limited to, brazing, press fitting, fastening, etc. Moreover, the shield elements 131h may cover a portion of the support block, thereby providing protection to such portion from wear and abrasion during operation of the cutting tool assembly 100h. For example, the shield elements 131h may comprise any of the superhard elements disclosed herein. In another embodiment, shield elements may comprise cemented tungsten carbide. For instance, cobalt-cemented tungsten carbide, which may be domed, flat, or otherwise shaped.

[0094] In some embodiments, the cutting element may be secured to the shield or integrated therewith. Moreover, in some instances, both the shield and the cutting element secured thereto may be removable and/or replaceable, with may extend useful life of the cutting assembly (*i.e.*, by replacing the shield and the cutting element). For example, **FIG. 5A** illustrates a cutting tool assembly 100j that includes cutting element 120j secured to a shield 130j. Except as otherwise described herein, the cutting tool assembly 100j and its materials, elements, or components may be similar to or the same as any of the cutting tool assemblies 100, 100a, 100b, 100c, 100d, 100e, 100f, 100g, 100h (**FIGS. 1A-1B, 3A-3C, 4A-4D**) and their respective materials, elements and components. For example, a support block 110j may be similar to or the same as the support block 110b (**FIG. 3A**). In an embodiment, the shield 130j may be fastened to a support block 110j with one or more threaded fastener 140j.

[0095] In some embodiments, the cutting element 120j may be brazed or otherwise secured to the shield 130j. Consequently, the threaded fastener 140j may secure both the shield 130j and the cutting element 120j by fastening the shield 130j to the support block 110j. As described above, the shield 130j may include a shielding face 131j that may shield a front face of the cutting tool assembly 100j. Furthermore, in some instances, the shield 130j also may form a top portion of the cutting tool assembly 100j. For example, the support block 110j may be truncated along a surface 111j, and the shield

130j may extend from the surface 111j upward, to form the top portion as well as the top of the cutting tool assembly 100j.

[0096] At least one embodiment, the cutting element 120j may include a superhard working surface 121j that may have an approximately parallel orientation relative to a longitudinal centerline 10j. As such, orienting the cutting tool assembly 100j on a rotary drum assembly (*see* **FIGS. 10A** and **10B**) in a manner that longitudinal centerline 10j aligns a radius centered on the center of rotation of the rotary drum assembly may orient the superhard working surface 121j in a manner that the superhard working surface 121j has no rake angle. As noted above, however, the cutting tool assembly 100j may have any suitable orientation on the rotary drum assembly, and the superhard working surface 121j may have a negative or positive rake angle when the cutting tool assembly 100j is secured to the rotary drum assembly.

[0097] It should be appreciated that the shield and the cutting element combination may be secured to the support block in any number of suitable ways. For example, **FIGS. 5B** and **5C** illustrate a cutting tool assembly 100k that includes an approximately conical shield 130k and cutting element 120k secured to or incorporated with the shield 130k. Except as otherwise described herein, the cutting tool assembly 100k and its materials, elements, or components may be similar to or the same as any of the cutting tool assemblies 100, 100a, 100b, 100c, 100d, 100e, 100f, 100g, 100h, 100j (**FIGS. 1A-1B, 3A-3C, 4A-4D, 5A**) and their respective materials, elements and components. For example, the shape of the cutting tool assembly 100k may be similar to or the same as the shape of the cutting tool assembly 100g (**FIG. 4C**). Moreover, as described below in further detail, it should be appreciated that the shield may have any suitable shape and/or size.

[0098] As shown in **FIG. 5B**, the combined shield 130k and cutting element 120k may be secured to a support block 110k. For example, the cutting tool assembly 100k may include a threaded fastener 140k that may fasten the shield 130k to the support block 110k. Moreover, the shield 130k may form a working end of the cutting tool assembly 100k. Furthermore, as shown in **FIG. 5C**, the support block 110k and the shield 130k may include corresponding locating features that may locate the shield 130k relative to the support block 110k (*e.g.*, concentrically with each other). For example, the locating feature of the support block 110k may include a tapered protrusion 150k, which may have the shape of a truncated cone, and which may be positioned within a corresponding recess 160k in the shield 130k. More specifically, the tapered protrusion 150k and the recess

160k may have the same, similar, or different taper angles, such as to align the shield 130k relative to the support block 110k.

[0099] It should also be appreciated that the cutting tool assembly 100k may include any suitable alignment feature, which may locate or orient the shield 130k relative to the support block 110k. For example, the shield may include a protrusion, while the support block may include a corresponding recess. Furthermore, the shield 130k and the support block 110 may include one or more recesses that may engage or accept one or more dowels.

[0100] Alignment features may have any suitable shape and/or size. For example, FIG. 5D illustrates another example of a suitable alignment feature included in a shield 130m. Except as otherwise described herein, the shield 130m and its materials, elements, or components may be similar to or the same as any of the shields 130, 130a, 130b, 130c, 130d, 130e, 130f, 130g, 130h, 130j, 130k (FIGS. 1A-1B and 3A-5C) and their respective materials, elements and components. In an embodiment, a cutting element 120m may be secured to the shield 130m. Furthermore, the shield 130m may include a recess 160m that may accept a corresponding protrusion of a support block. More specifically, the recess 160m may accept a pyramid-shaped protrusion, which may align and/or orient the shield 130m relative to the support block. It should be appreciated that the multi-sided shapes of the recess 160m and the corresponding protrusion of the support block may facilitate axial orientation of the shield 130m relative to the support block about a longitudinal centerline 10m.

[0101] As noted above, the shield may have any suitable shape and/or size. In some instances, as shown in FIG. 5D, the shield 130m may have a pyramid-like shape. Furthermore, in some embodiments, the pyramid-like shield may include radii or fillets or chamfers extending between adjacent sides thereof. Also, embodiments may include a shield that has an approximately rectangular or cylindrical shape or other suitable shapes.

[0102] In some embodiments, the alignment feature also may include an attachment mechanism, which may facilitate attachment of the shield to the support block. In one example, the shield 130m may include a threaded hole 119m that may accept and be secured by a threaded fastener. Additionally or alternatively, as shown in FIG. 5E a shield 130n may include a recess 160n that has a channel 161n that may facilitate securing the shield 130n to a support block 110n. Except as otherwise described herein, the shield 130n and its materials, elements, or components may be similar to or the same as any of the shields 130, 130a, 130b, 130c, 130d, 130e, 130f, 130g, 130h, 130j,

130k, 130m (**FIGS. 1A-1B** and **3A-5D**) and their respective materials, elements and components. For example, at least a portion of the recess 160n may have tapered walls, similar to or the same as any of the shields 130k, 130m (**FIGS. 5C-5D**).

[00103] In an embodiment, the support block 110n may include a protrusion 150n that may be shaped and sized to correspond with the shape and size of the recess 160n. In some instances, the recess 160n and the protrusion 150n may include a straight or non-tapered portion that may facilitate attachment of the shield 130n to the support block 110n. For example, the straight portion of the protrusion 150n may include one or more features that may enter and/or may be secured within the channel 161n.

[00104] In an embodiment, an expandable or deformable element (*e.g.*, a semispherical, a hemispherical, or a ring-like element) may be positioned within or engage the channel 161n. For example, an expandable element 170n, such as a split ring, a snap ring, or circlip may be placed or positioned about the protrusion 150n. The expandable element 170n may include resilient material and may be compressible about the protrusion 150n. As such, the expandable element 170n may be compressed as the protrusion 150n enters the recess 160n and may at least partially expand toward the uncompressed state after entering the channel 161n. When positioned within the channel 161n, the expandable element 170n may secure the shield 130n to the support block 110n.

[00105] As shown in **FIG. 5F**, in one or more embodiments, a shield 130p may include a threaded portion that may be threaded to a corresponding portion of a support block 110p, thereby securing together the shield 130p and the support block 110p. Except as otherwise described herein, the shield 130p and its materials, elements, or components may be similar to or the same as any of the shields 130, 130a, 130b, 130c, 130d, 130e, 130f, 130g, 130h, 130j, 130k, 130m, 130n (**FIGS. 1A-1B, 3A-5E**) and their respective materials, elements and components. For example, the shield 130p may include a recess 160p that may be similar to the recess 160n (**FIG. 5E**).

[00106] In at least one embodiment, the recess 160p may include a threaded portion 161p that may accept a threaded member that may secure the shield 130p to the support block 110p. For example, the support block 110p may include a protrusion 150p that may have a corresponding shape and size with the recess 160p. In particular, in an embodiment, the protrusion 150p may include a threaded portion 151p that may be threaded into the threaded portion 161p to secure the shield 130p to the support block 110p. It should be appreciated that the corresponding tapered portions of the recess 160p and protrusion 150p may align the shield 130p relative to the support block 110p.

[00107] In some instances, a securing mechanism may be included to prevent unscrewing the shield 130p from the support block 110p during operation. For example, a compressible or lock washer may be placed between the shield 130p and support block 110p. Additionally or alternatively, a thread-locking substance (*e.g.*, LOCTITE®
5 THREADLOCKER) may be placed between the threaded portion 161p and the threaded portion 151p. In any event, the threaded portions 151p, 161p may securely attach the shield 130p to the support block 110p, such that the shield 130p may remain attached together during operation of the cutting tool assembly.

[00108] As described above, cutting tool assemblies may include multiple cutting
10 elements or multi-faced cutting elements, which in some instances may facilitate indexing the cutting tool assemblies in a manner that extends the useful life thereof. **FIG. 6A** illustrates a cutting tool assembly 100q that may include a cutting element 120q secured to a support block 110q. Except as otherwise described herein, the cutting tool assembly 100q and its materials, elements, or components may be similar to or the same as any of
15 the cutting tool assemblies 100, 100a, 100b, 100c, 100d, 100e, 100f, 100g, 100h, 100j, 100k (**FIGS. 1A-1B, 3A-3C, and 4A-5C**) and their respective materials, elements and components. For example, the shape of the cutting tool assembly 100q may be similar to or the same as the shape of the cutting tool assembly 100d (**FIG. 3C**).

[00109] In an embodiment, the cutting element 120q may be a generally convex-
20 shaped strip of superhard material that includes superhard working surfaces 121q, 121q'. More specifically, the superhard working surface 121q may face in a first direction, while the superhard working surface 121q' may face in a second, different direction. In some embodiment, the second direction may be opposite to the first direction. In one embodiment, the cutting tool assembly 100q and the superhard working surface 121q may
25 be positioned and/or oriented in a manner that facilitates engagement of the superhard working surface 121q with the target material during operation of the cutting tool assembly 100q. As the superhard working surface 121q wears beyond a usable or suitable state, however, the cutting tool assembly 100q or a portion thereof may be reoriented, repositioned, or indexed in a manner that allows the superhard working
30 surface 121q' to engage the target material during the operation of the cutting tool assembly 100q.

[00110] For example, the cutting tool assembly 100q may be rotated 180° (*e.g.*, about a center axis thereof) to index the superhard working surface 121q' into a cutting position. It should be appreciated that a particular location and orientation of the

superhard working surface 121q and of the superhard working surface 121q' may vary from one embodiment to the next. In some instances, the superhard working surfaces may be positioned at about a 90° angles relative to one another or at any other suitable angle that may facilitate indexing of the cutting tool assembly 100q to place one or more
5 of the working services into cutting position. In any event, in some embodiments, during the operation of the cutting tool assembly, as one or more of the working surfaces and/or of the cutting elements wears beyond a useful state, the cutting tool assembly may be rotated or indexed to place another superhard working surface into the cutting position.

[00111] In some embodiments, the cutting tool assembly 100q may include a shield
10 130q, which may be similar to or the same as any shield described herein. In some embodiments, the shield 130q may have a shape of a truncated, two-sided pyramid. The cutting element 120q may be attached to the shield 130q, which may secure the cutting element 120q to the support block 110q. In one example, the shield 130q also may be secured to the support block 110q. Alternatively, however, the shield 130q may be
15 removably and/or replicable secured to the support block 110q. As such, the shield 130q may be loosened and/or detached from the support block 110q and indexed to place any of the superhard working surfaces 121q, 121q' into the cutting position.

[00112] In additional or alternative embodiments, as shown in **FIG. 6B**, a cutting tool assembly 100r may include multiple cutting elements, such as cutting element 120r
20 and cutting element 120r', each of which may include one or more superhard working surfaces that may be indexed or selectively positioned into a cutting position. Except as otherwise described herein, the cutting tool assembly 100r and its materials, elements, or components may be similar to or the same as any of the cutting tool assemblies 100, 100a, 100b, 100c, 100d, 100e, 100f, 100g, 100h, 100j, 100k, 100q (**FIGS. 1A-1B, 3A-3C, 4A-
25 5C, and 6A**) and their respective materials, elements and components. For example, the cutting tool assembly 100r may have a similar shape and/or size as the cutting tool assembly 100q (**FIG. 6A**).

[00113] In some embodiments, the cutting elements 120r, 120r' may be secured to a support block 110r. Moreover, the cutting elements 120r, 120r' may include
30 corresponding superhard working surfaces 121r, 121r'. In one example, the superhard working surface 121r may face in opposing directions from the superhard working surface 121r'. Alternatively, however, the superhard working surface 121r and the superhard working surface 121r' may be oriented relative to each other in any suitable manner that allows indexing or selective positioning thereof, as described above.

[00114] In an embodiment, the cutting tool assembly 100r may include multiple shields, such as shields 130r, 130r'. More specifically, the shield 130r may protect the support block 110r and the cutting element 120r when the cutting tool assembly 100r is indexed or positioned in a manner that places the cutting element 120r into the working or cutting position. Similarly, the shield 130r' may protect the support block 110r and the cutting element 120r' when the cutting tool assembly 100r is indexed or positioned in a manner that places the cutting element 120r' into the working or cutting position.

[00115] As mentioned above, the cutting tool assembly may include any suitable number of cutting elements as well as shield elements. As shown in FIG. 7, a cutting tool assembly 100t may include multiple cutting elements 120t secured to a support block 110t. Except as otherwise described herein, the cutting tool assembly 100t and its materials, elements, or components may be similar to or the same as any of the cutting tool assemblies 100, 100a, 100b, 100c, 100d, 100e, 100f, 100g, 100h, 100j, 100k, 100q, 100r (FIGS. 1A-1B, 3A-3C, 4A-5C, and 6A-6B) and their respective materials, elements and components. For example, the cutting tool assembly 100t may have a similar shape and/or size as the cutting tool assembly 100q (FIG. 6A).

[00116] In at least one embodiment, the cutting elements 120t may include corresponding superhard working surfaces 121t that may face approximately in the same direction. For example, the superhard working surfaces 121t may be approximately planar. Moreover, the superhard working surfaces 121t may lie an approximately the same plane with one another (*e.g.*, in a flat plane).

[00117] The superhard working surfaces 121t may be arranged on the support block 110t in any number of suitable configurations. In some embodiments, the superhard working surfaces 121t may be arranged in multiple rows. Furthermore, each of the rows may include different number of the superhard working surfaces 121t. In an embodiment, the superhard working surfaces 121t may be arranged in a manner that follows at least a portion of the outer contour of a front face 111t of the support block 110t.

[00118] As described above, in an embodiment, the cutting tool assembly 100t may include multiple shield elements 131t (*e.g.*, any superhard element disclosed herein) that collectively may form a shield 130t. For instance, one or more shield elements 131t may be polycrystalline diamond. Additionally or alternatively, one or more shield elements 131t may be cemented tungsten carbide (*e.g.*, cobalt cemented tungsten carbide). The shield elements 131t also may be arranged in multiple rows and may generally fill one or

more surfaces of the support block 110t, in a manner that protects such surfaces. For example, the shield elements 131t may be positioned on a slanted surface 112t of the support block 110t, thereby protecting the slanted surface 112t.

[00119] As mentioned above, in some embodiments, the cutting tool assembly may be shaped in a manner that reduces or minimizes wear of the support block during the operation of the cutting tool assembly. As described below in further detail, the cutting tool assemblies may be secured to a rotary drum assembly. Moreover, as the rotary drum assembly moves the cutting tool assemblies through the target material and fails such target material, the failed material may be passed through the rotary drum assembly and may abrade the cutting tool assemblies. In some instances, cutting tool assemblies located on the left side of the rotary drum assembly may be abraded on the right side thereof and vice versa.

[00120] FIGS. 8A and 8B illustrate a cutting tool assembly 100u that includes a support block 110u with working end 111u and a mounting end 112u. Except as otherwise described herein, the cutting tool assembly 100u and its materials, elements, or components may be similar to or the same as any of the cutting tool assemblies 100, 100a, 100b, 100c, 100d, 100e, 100f, 100g, 100h, 100j, 100k, 100q, 100r (FIGS. 1A-1B, 3A-3C, 4A-5C, and 6A-7) and their respective materials, elements and components. As shown in FIG. 8A, in an embodiment, a cutting element 120u may be secured to the working end 111u of the support block 110u.

[00121] Additionally, the support block 110u may include a carve-out 180u that may allow the failed target material to pass by the support block 110u without contacting or with reduced contact with the support block 110u. For example, the cutting tool assembly 100u may be secured on a left side of the rotary drum assembly and may include a carve-out 180u on a right side of the support block 110u (as viewed from the side of a superhard working surface 121u). The carve-out 180u may form the working end 111u of the support block 110u. Particularly, in an embodiment, the working end 111u may have a smaller width than the mounting end 112u of the support block 110u. Furthermore, in some embodiments, a side of the working end 111u may be oriented at a non-orthogonal angle relative to a top face 113u of the mounting end 112u. For example, the side of working end 111u may form an acute angle γ with an imaginary reference line 119.

[00122] In some embodiments, the working end 111u may have a length L and width W. For example, the length L may be greater than the width W by a factor (*i.e.*, $L = \text{factor} \times W$) in one or more of the following ranges: between about 1.2 and 1.5; between about 1.4 and 2; between about 1.6 and 3; and between about 2.5 and 5. It should be also appreciated that the factor correlating length L to width W may be less than 1.2 or greater than 5. Thus, as shown in **FIGS. 8A-8F**, the working end 111u constitutes an elongated region of the cutting tool assembly 100u that extends from the mounting end 112u and the width W of the working end 111u/elongated region is reduced/less relative to a width of the mounting end 112u.

10 [00123] In any event, however, the carve-out 180u may allow the failed material to pass by the support block 110u in a manner that may reduce or minimize contact of the failed material with the support block 110u. Furthermore, as shown in **FIGS. 8A** and **8B**, in some embodiments, the cutting tool assembly 100u may include a shield 130u. For example, the shield 130u may include hardfacing, protective coating, and the like.

15 [00124] As described above, the wear of the cutting tool assemblies mounted on the rotary drum assembly may vary from one embodiment to the next. In some instances, the cutting tool assemblies mounted on the right side of the rotary drum assembly (as viewed from the front-facing side of the rotary drum assembly) may wear on the left side of the cutting tool assemblies. **FIGS. 8C** and **8D** illustrates a cutting tool assembly 100w that may be secured on the right side of the rotary drum assembly. Except as otherwise described herein, the cutting tool assembly 100w and its materials, elements, or components may be similar to or the same as any of the cutting tool assemblies 100, 100a, 20 100b, 100c, 100d, 100e, 100f, 100g, 100h, 100j, 100k, 100q, 100r, 100u (**FIGS. 1A-1B, 3A-3C, 4A-5C, and 6A-8B**) and their respective materials, elements and components. For example, the cutting tool assembly 100w may be the same as the cutting tool assembly 100u (**FIGS. 8A** and **8B**), but may be a mirrored image thereof. Particularly, the cutting tool assembly 100w may include a support block 110w that has a carve-out 180w on a left side thereof. Further, optionally, cutting tool assembly 100w may include a shield, which may be configured according to any of the embodiments disclosed herein, 25 or combinations thereof.

30 [00125] In an embodiment, the support block 110w may have a working end that has a length L that may be similar to or the same as length L of the support block 110u (**FIGS. 8A-8B**). Also, in at least one embodiment, the working end of the support block

110w may form an angle γ with the remaining portion of the support block 110w. In some instances, the angle γ formed between the working end and the remaining portion of the support block 110w may be similar to or the same as the angle γ formed between the working end 111u and the remaining portion of the support block 110u (**FIGS. 8A-8B**).

5 **[00126]** In some embodiment, the cutting tool assembly may include multiple carve-outs. For example, multiple carve-outs in the support block of the cutting tool assembly may facilitate interchangeability of the cutting tool assembly, such that the cutting tool assembly may be secured to either the left or the right side of the rotary drum assembly. **FIGS. 8E** and **8F** illustrate a cutting tool assembly 100x that may have a
10 support block 110x that includes opposing carve-outs 180x, 180x'. Except as otherwise described herein, the cutting tool assembly 100x and its materials, elements, or components may be similar to or the same as any of the cutting tool assemblies 100, 100a, 100b, 100c, 100d, 100e, 100f, 100g, 100h, 100j, 100k, 100q, 100r, 100u, 100w (**FIGS. 1A-1B, 3A-3C, 4A-5C, and 6A-8E**) and their respective materials, elements and
15 components. For example, the cutting tool assembly 100x may include a cutting element 120x that may be similar to or the same as the cutting element 120u (**FIGS. 8A-8B**). Further, optionally, cutting tool assembly 100x may include a shield, which may be configured according to any of the embodiments disclosed herein, or combinations thereof.

20 **[00127]** In some embodiments, the carve-outs 180x, 180x' may form a working end 111x of the support block 110x that is thinner than a mounting end 112x of the support block 110x. Particular, the carve-outs 180x, 180x' may form the working end 111x that extends above the mounting end 112x of the support block 110x (*e.g.*, extends by a length L, which may be similar to or the same as length L of the working end 111u
25 of the support block 110u (**FIGS. 8A-8B**). In some instances, the support block 110x may include one or more radii 200x that may extend between at least a portion of the peripheral surface of the working end 111x and the mounting end 112x. In any event, however, the carve-outs 180x, 180x' may allow material failed and moved by the rotary drum assembly to pass by the support block 110x with reduced abrasion (as compared
30 with a cutting tool assembly having a support block that does not include such carve-outs).

[00128] In some embodiments, as shown in **FIG. 8E**, the working end 111x of the support block 110x may include a seat 210x that may locate the cutting element 120x

(**FIG. 8F**) relative to the working end 111x and to the support block 110x. In one example, the cutting element 120x (**FIG. 8F**) may have a circular cross-section. Accordingly, the seat 210x may have at least partially cylindrical or circular shape that may match the cylindrical peripheral surface of the cutting element 120x (**FIG. 8F**).

5 [00129] As mentioned above, in some instances, the cutting element may be removable and/or replaceable. Moreover, some cutting tool assemblies may include a fastener that may secure the cutting elements to the support block. For example, the cutting element 120x (**FIG. 8F**) may be secured to the support block 110x with a fastener (not shown) that may pass through an opening 119x and may threadedly engage the
10 cutting element 120x, thereby securing the cutting element 120x to the support block 110x.

[00130] In some examples, the cutting element 120x (**FIG. 8F**) may be removed and/or replaced. For instance, the fastener that may secure the cutting element 120x (**FIG. 8F**) to the support block 110x may be unfastened from the cutting element 120x
15 (**FIG. 8F**), thereby providing for removal of the cutting element 120x (**FIG. 8F**) from the support block 110x. Furthermore, in at least one embodiment, the cutting element 120x (**FIG. 8F**) and the seat 210x may be configured to allow indexing of the cutting element 120x (**FIG. 8F**).

[00131] For example, the cutting element 120x (**FIG. 8F**) may be rotated (*e.g.*,
20 about a center axis thereof) to expose unused or unworn portions thereof to target material. It should be appreciated that cutting elements may have any number of suitable shapes. Hence, for instance, a square, triangular, cylindrical, or polygonal cutting element may be rotated or indexed in a manner that exposes one or more unworn sides of the cutting element to the target material. Additionally or alternatively, the cutting
25 elements (*e.g.*, the cutting element 120x (**FIG. 8F**)) may be indexed in a manner that places an inward facing side thereof (*i.e.*, the side facing the seat 210x) outward, toward the target material.

[00132] While the cutting tool assemblies described above include cutting elements having generally planar surfaces, this disclosure is not so limited. More specifically,
30 working surfaces of the cutting elements may vary from one embodiment to the next and may depend, among other things, on target material intended to be failed thereby. For example, **FIG. 9A** illustrates a cutting element 120y that includes a non-planar superhard working surface 121y. It should be appreciated that the cutting element 120y may be included in any of the cutting tool assemblies described herein.

[00133] At least one embodiment includes the cutting element 120y that has a convex, conical, or dome-shaped superhard working surface 121y. Moreover, the cutting element 120y may include semi-spherical or generally rounded superhard working surface 121y. The superhard working surface 121y may be formed by or on a superhard table 122y that may be bonded to a substrate 123y. In some instances, at least a portion of an interface 124y between the superhard table 122y and the substrate 123y may be non-planar. For instance, at least a portion of the interface 124y may approximate or follow the shape (or portion of the shape) of the superhard working surface 121y. Alternatively, the interface between the superhard table and the substrate may be substantially planar.

[00134] In some embodiments, the substrate may be approximately cylindrical and/or may have an approximately uniform peripheral surface (*e.g.*, the substrate may have an approximately uniform or unchanging cross-sectional perimeter). Alternatively, as shown in **FIG. 9B**, the substrate may include one or more steps. In particular, **FIG. 9B** illustrates a cutting element 120z, which includes a superhard table 122z bonded to the substrate 123z. More specifically, in an embodiment, the substrate 123z includes an upper bonding portion 125z and a lower stem portion 126z, which may be attached to or integrated with the bonding portion 125z.

[00135] In some instances, the bonding portion 125z may have an approximately the same peripheral size and/or shape as the superhard table 122z. Furthermore, in an embodiment, the stem portion 126z may have a different peripheral size and/or shape than the bonding portion 125z (*e.g.*, the stem portion 126z may have a smaller outside diameter than the bonding portion 125z). It should also be understood that the cutting element 120z may be included in any of the cutting tool assemblies described herein.

[00136] **FIG. 10A** illustrates an embodiment of a rotary drum assembly 300, which may include any number of cutting tool assemblies, such as cutting tool assemblies 100u, 100w. It should be appreciated, however, that the rotary drum assembly 300 may include any of the cutting tool assemblies described herein or combinations thereof. In addition, the rotary drum assembly 300 may include one or more conventional cutting tools (*e.g.*, conventional tools that do not include a superhard working surface).

[00137] In an embodiment, the rotary drum assembly 300 includes a drum body 310 that may have an outer surface 320, which may have a substantially cylindrical shape. It should be appreciated that the shape of the outer surface 320 may vary from one embodiment to the next. For example, the outer surface 320 may have oval or other non-

cylindrical shapes. In addition, the drum body 310 may be solid, hollow, or tubular (*e.g.*, the drum body 310 may have a cored-out inner cavity or space). In any event, the drum body 310 may have sufficient strength and rigidity to secure the cutting tool assemblies 100u, 100w and to remove material, as may be suitable for a particular application.

5 [00138] Similarly, a cutting exterior of the rotary drum assembly 300, which may be formed or defined by the cutting tool assemblies 100u, 100w, may have an approximate cylindrical shape. More specifically, superhard working surfaces of the cutting tool assemblies 100u, 100w, collectively, may form an approximately cylindrical cutting exterior. It may be appreciated that the particular shape of the cutting exterior
10 formed by the cutting tool assemblies 100u, 100w may depend on the shape of the superhard working surfaces and on the orientation of the cutting tool assemblies 100u, 100w relative to the drum body 310, among other things.

[00139] Moreover, the cutting tool assemblies 100u, 100w may have any number of suitable patterns and/or configurations on the drum body 310, which may vary from
15 one embodiment to the next. For example, cutting tool assemblies 100u, 100w may form helical rows about the drum body 310, and such rows may wrap about the circumference of the drum body 310. Furthermore, helical row(s) formed by the cutting tool assembly 100u may have a different orientation of the helix than the helical row(s) formed by the cutting tool assembly 100w. In any event, the cutting exterior of the rotary drum
20 assembly 300 may rotate about the center axis of the drum body 310 to cut, grind, or otherwise fail the target material by engaging the target material with the cutting tool assemblies 100u, 100w.

[00140] Additionally, the helical arrangement may facilitate movement of the failed material between the cutting tool assemblies 100u, 100w and removal thereof from
25 a worksite. Also, the rotary drum assembly 300 may include one or more paddles 330, which may be located between the cutting tool assembly 100w and/or cutting tool assembly 100u, as shown. The paddles 330 may facilitate transferring of the failed material away from the worksite (*e.g.*, to a conveyor belt in a material-removing machine).

30 [00141] **FIG. 10B** illustrates an embodiment of a material-removal machine 400, which may incorporate the drum assembly 300. Particularly, as the material-removal machine 400 moves (*e.g.*, in a direction indicated by an illustrated arrow), the drum assembly 300 may rotate in a manner that produces material failure and/or removal.

[00142] In some instances, the rotation of the drum assembly 300 and movement of the material-removing machine 400 may produce conventional cutting motion, where cutting tool assemblies engage the target material in the same direction as the direction of the movement of the material-removal machine 400 (*i.e.*, as shown in **FIG. 10B**).

5 Alternatively, the rotation of the drum assembly 300 and movement of the material-removing machine 400 may produce a climb cutting motion, where the cutting tool assemblies of the drum assembly 300 engage the target material in a direction opposite to the movement of the material-removing machine 400. Furthermore, in some instances, the material-removing machine 400 may engage material at a final or finished depth of cut. Alternatively, the material-removing machine 400 may engage the target material at an unfinished or partial depth, such as to achieve the finished depth after multiple passes. In any case, rotation of the drum assembly 300 together with the movement of the material-removal machine 400 may remove at least a portion of the target material.

[00143] In an embodiment, movement of the material-removal machine 400 together with the rotation of the drum assembly 300 may remove a portion of a pavement 20, thereby producing a cut surface 21. Removed pavement may be subsequently recycled. Additionally or alternatively, the material-removal machine 400 may remove material in any number of suitable applications, including above ground and underground mining.

20 [00144] While various aspects and embodiments have been disclosed herein, other aspects and embodiments are contemplated. The various aspects and embodiments disclosed herein are for purposes of illustration and are not intended to be limiting. Additionally, the words “including,” “having,” and variants thereof (*e.g.*, “includes” and “has”) as used herein, including the claims, shall be open ended and have the same meaning as the word “comprising” and variants thereof (*e.g.*, “comprise” and “comprises”).

CLAIMS

We claim:

1. A cutting tool assembly configured for mounting to a material removing machine, the cutting tool assembly comprising:
 - 5 a support block having a mounting end and a working end, the mounting end being sized and configured to attach to the material removing machine;
 - a cutting element secured to the working end of the support block, the cutting element having a working surface that includes a superhard material; and
 - 10 a shield secured to the working end of the support block, the shield being sized and configured to protect at least a portion of the working end during operation of the cutting tool assembly.
2. The cutting tool assembly of claim 1, wherein the shield is positioned at least proximate to the cutting element.
3. The cutting tool assembly of claim 1, wherein the shield has one or more
15 of a higher hardness than the support block, a higher erosion resistance than the support block, or a higher abrasion resistance than the support block.
4. The cutting tool assembly of claim 1, wherein the shield includes one or more of a rubber, a plastic, a hardened steel, tungsten carbide, cubic boron nitride, or diamond.
- 20 5. The cutting tool assembly of claim 1, wherein the shield includes one or more of a hardfacing, a coating, or plating applied to at least a portion of the working end of the support block.
6. The cutting tool assembly of claim 1, wherein the shield is removably secured to the support block.
- 25 7. The cutting tool assembly of claim 6, wherein the shield is bonded, brazed, threadedly fastened, or mechanically attached to the support block.
8. The cutting tool assembly of claim 1, wherein the shield has an approximately conical or an approximately pyramid-like shape.
9. The cutting tool assembly of claim 1, wherein the superhard material
30 includes polycrystalline diamond.
10. The cutting tool assembly of claim 1, wherein the working surface is approximately parallel to a longitudinal centerline of the support block.
11. The cutting tool assembly of claim 1, wherein the working face is oriented at a non-parallel angle relative to a longitudinal centerline of the support block.

12. The cutting tool assembly of claim 1, further comprising at least a second cutting element secured to the support block, the at least a second cutting element having a working surface that includes a superhard material.

5 13. The cutting tool assembly of claim 12, wherein the working surface of the second cutting element has a different orientation than the working surface of the cutting element, and the cutting tool assembly is configured to be indexed in a manner that selectively positions the working surface of the cutting element or the working surface of the second cutting element.

10 14. The cutting tool assembly of claim 1, wherein the support block and the shield include corresponding locating features that locate the shield relative to the support block.

15 15. A rotary drum assembly, comprising:
a drum body; and
at least one cutting tool assembly mounted to the drum body, the at least one cutting tool assembly configured as any one of the cutting tool assemblies of claims 1-14.

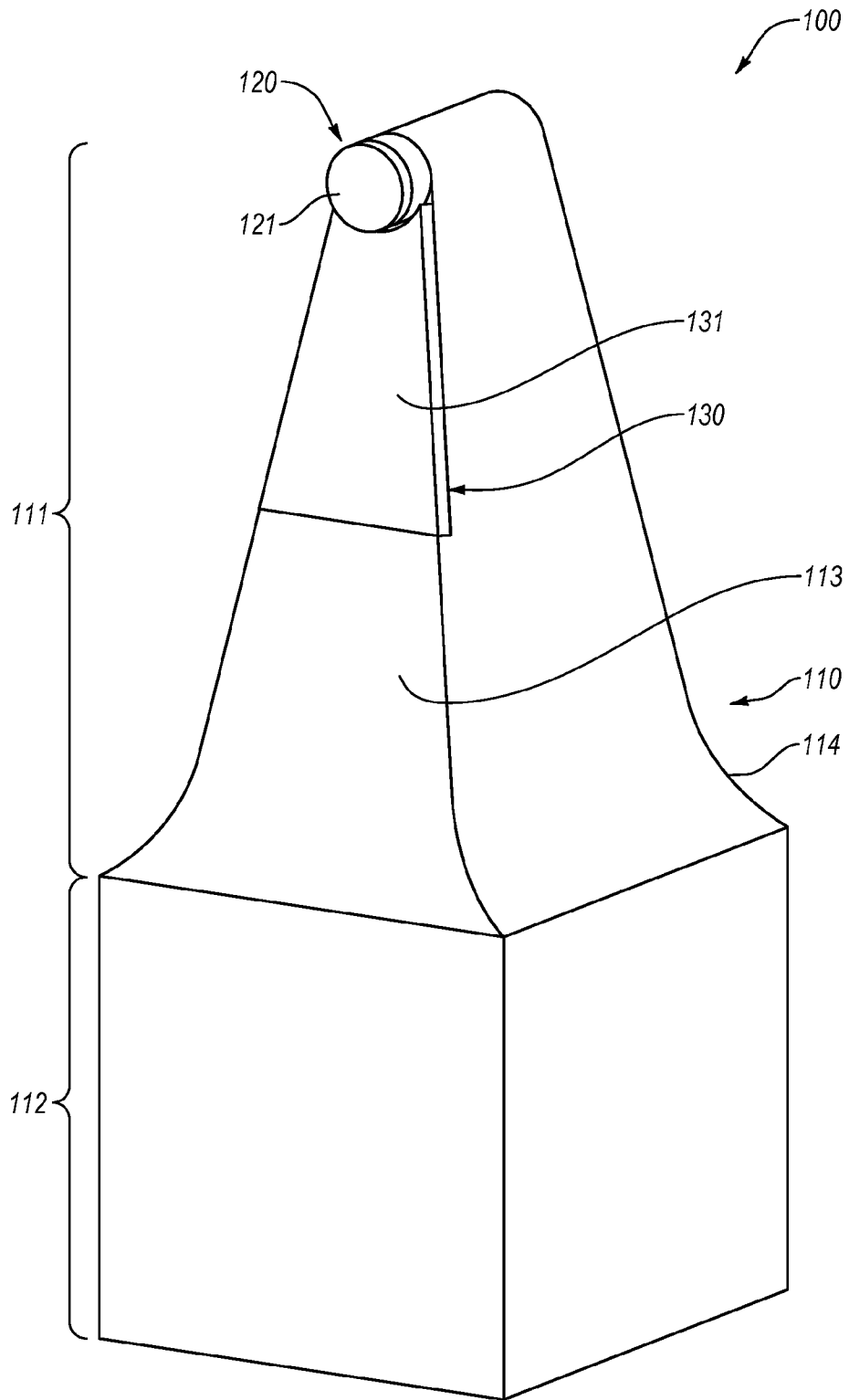

Fig. 1A

2 / 17

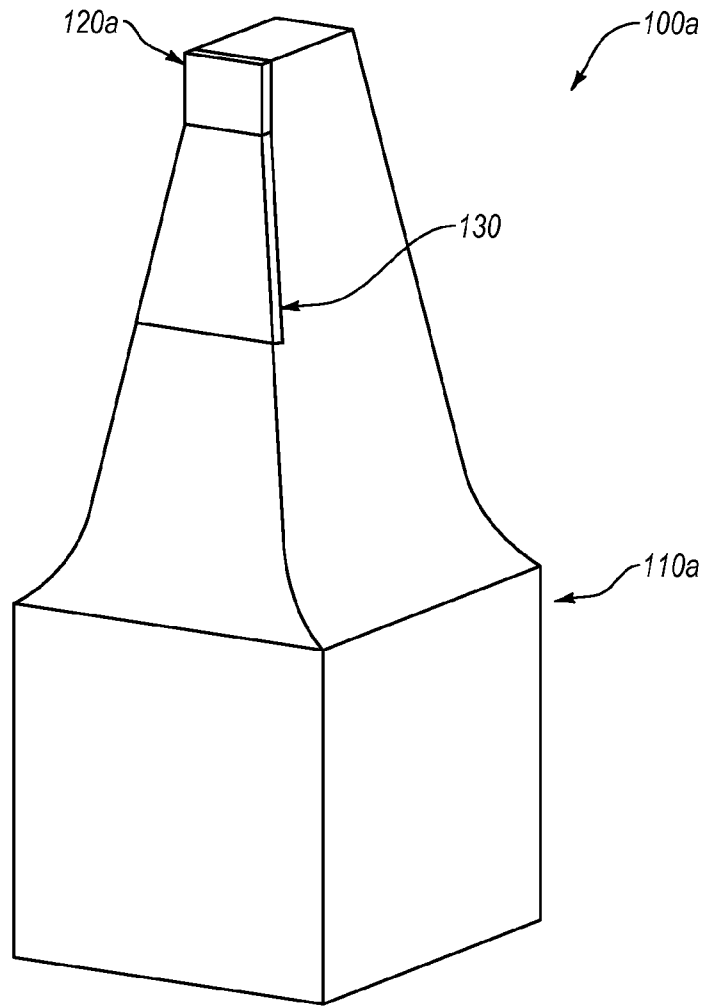

Fig. 1B

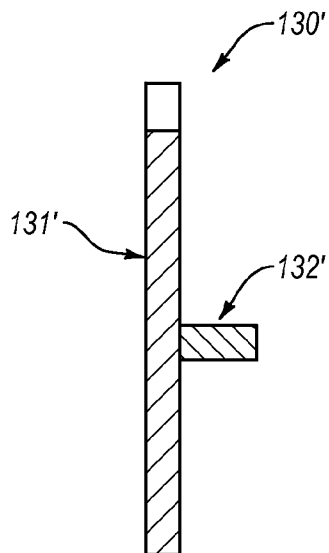

Fig. 2A

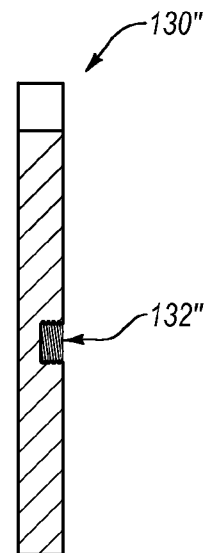

Fig. 2B

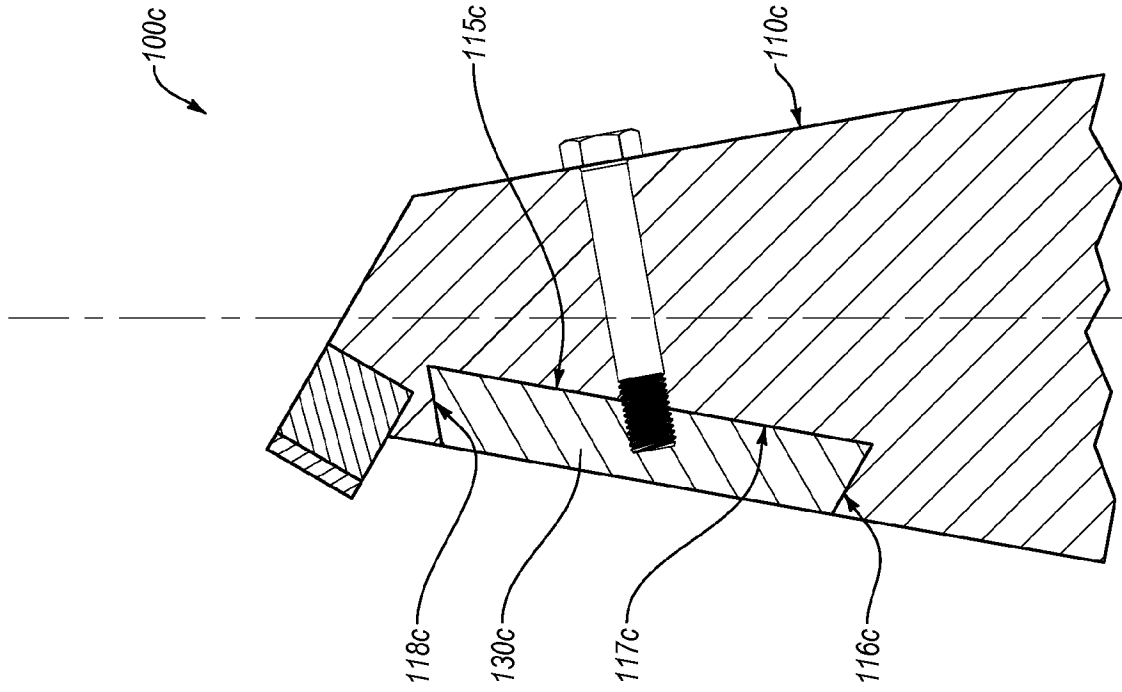

Fig. 3B

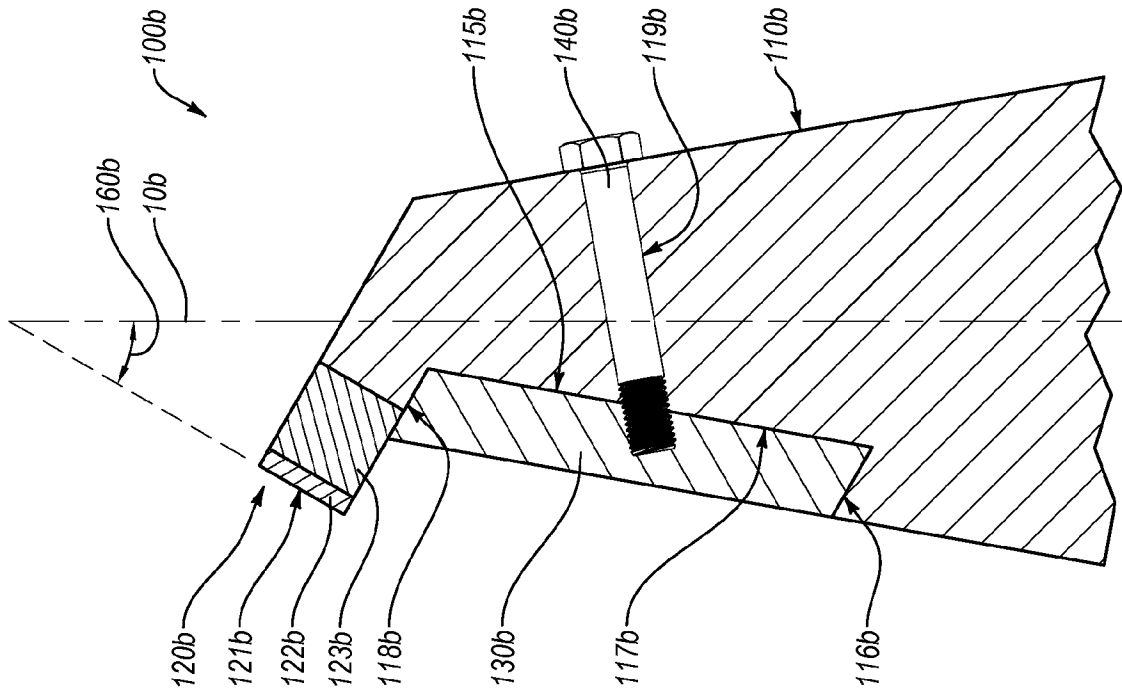

Fig. 3A

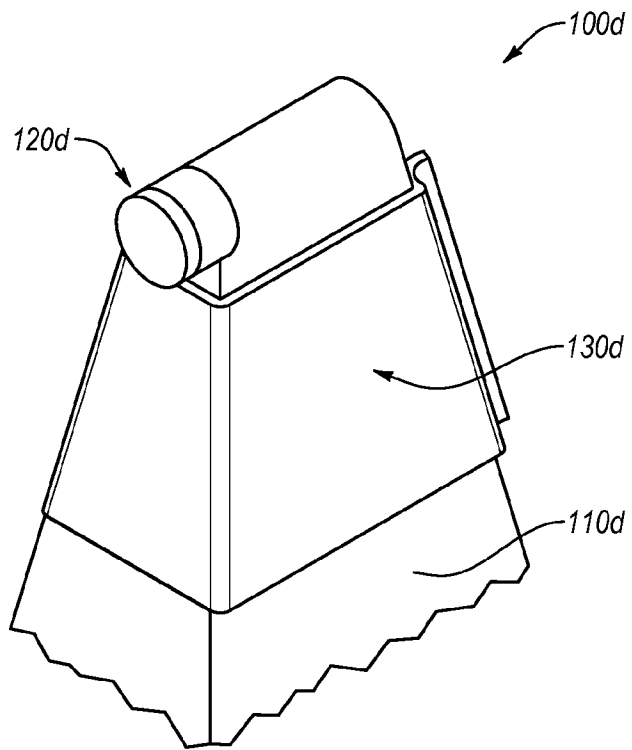

Fig. 3C

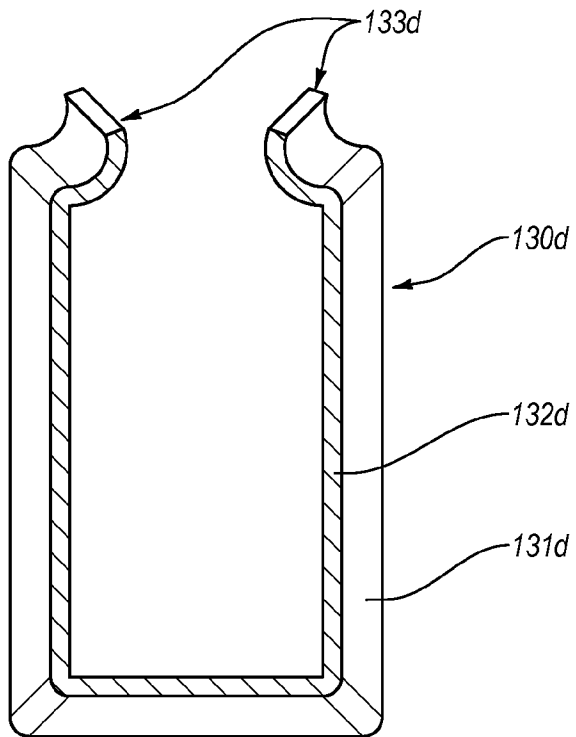

Fig. 3D

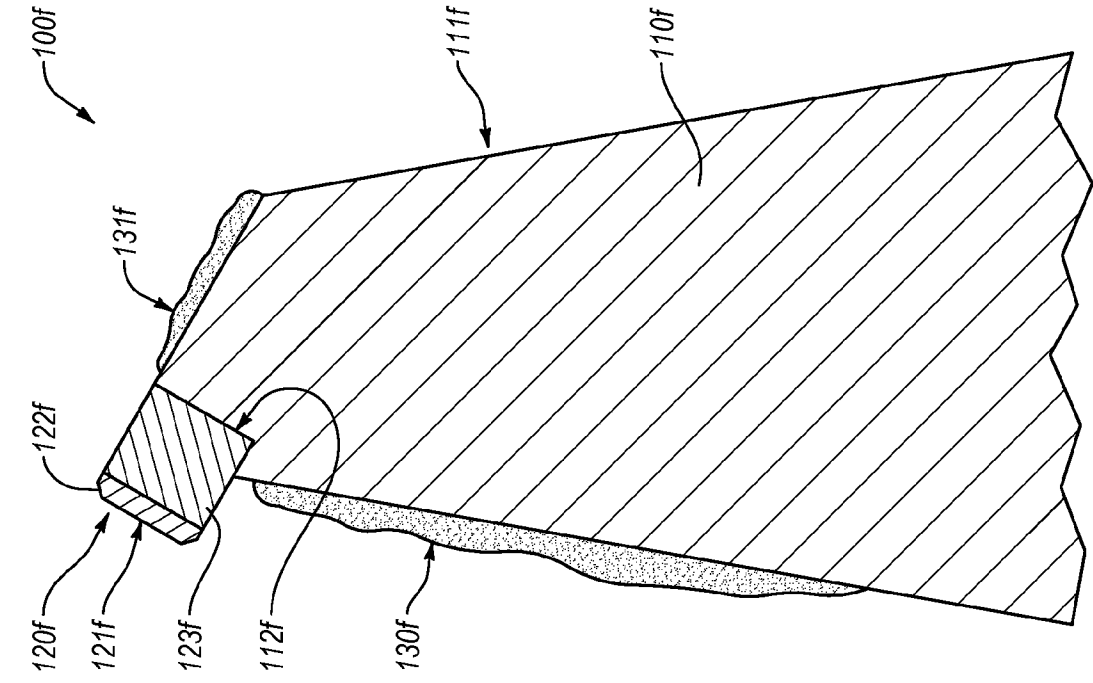

Fig. 4B

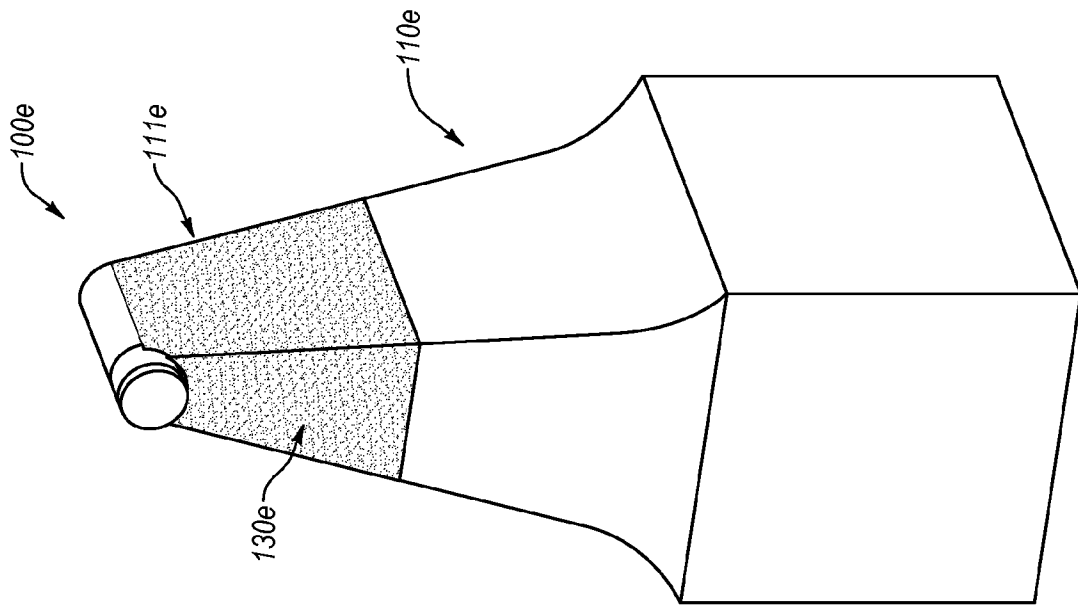

Fig. 4A

6 / 17

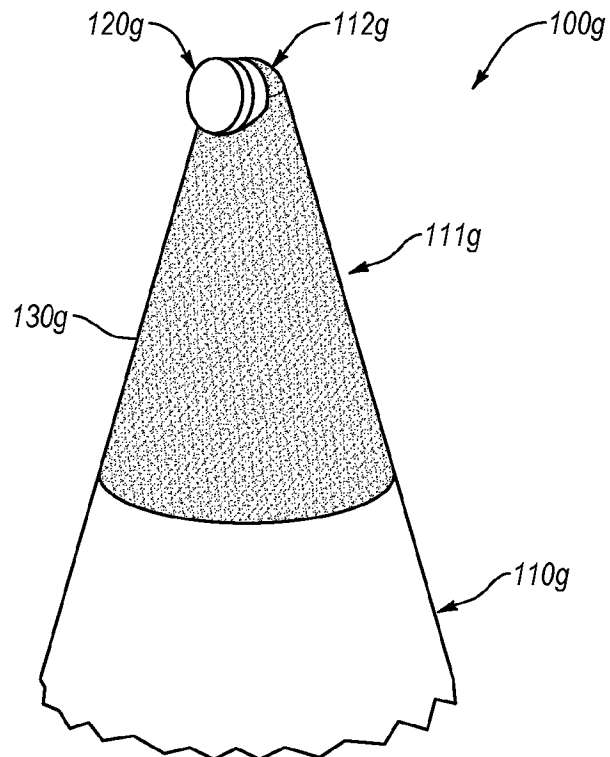

Fig. 4C

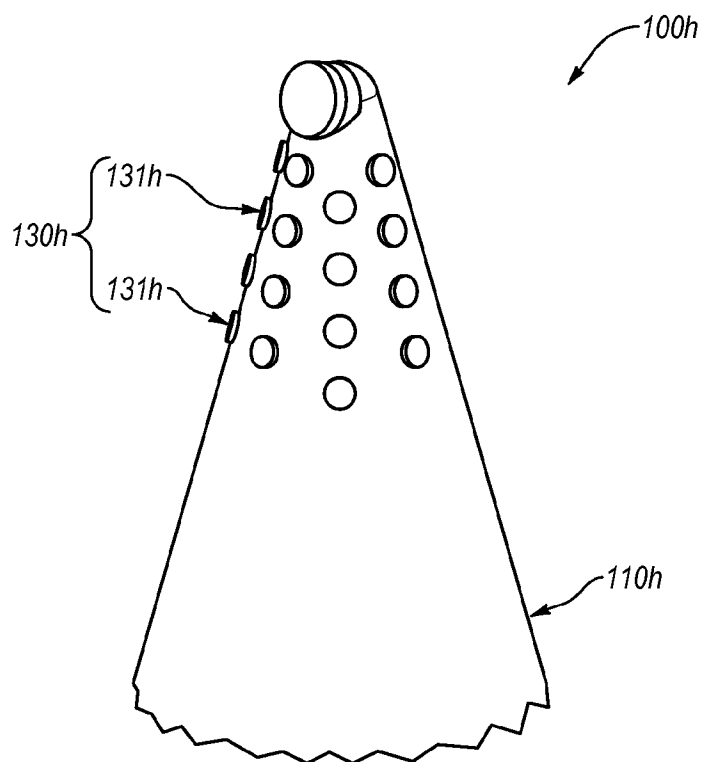

Fig. 4D

7 / 17

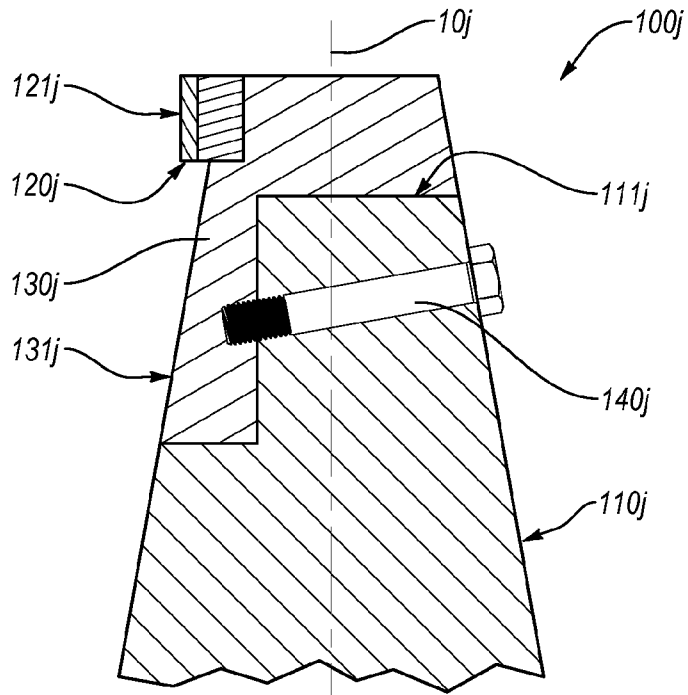

Fig. 5A

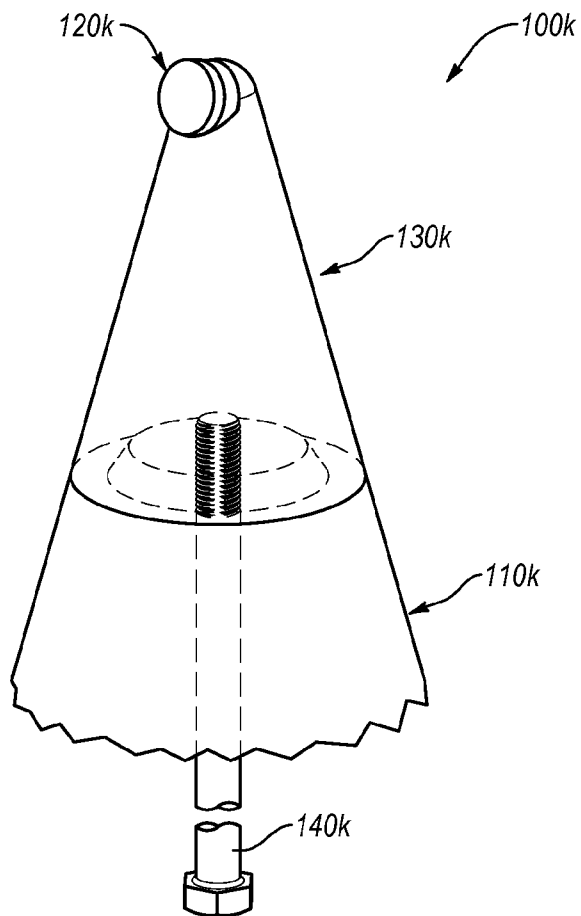

Fig. 5B

8 / 17

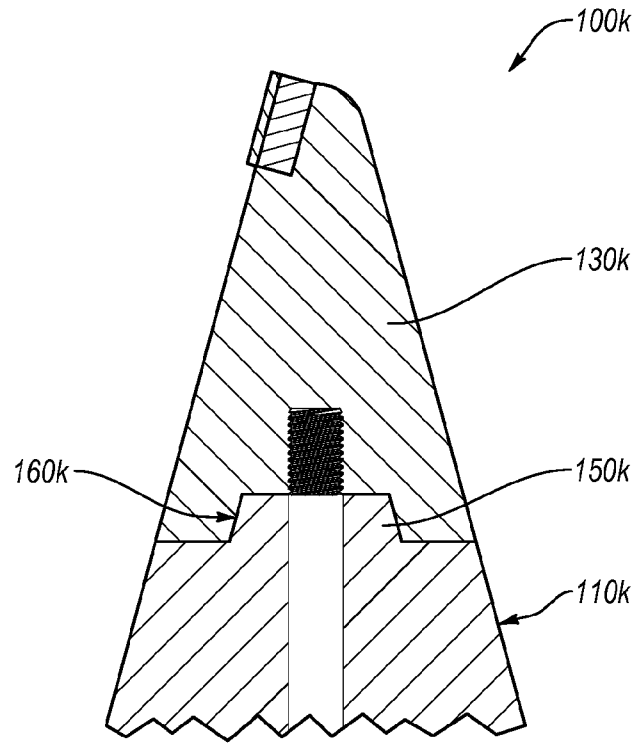

Fig. 5C

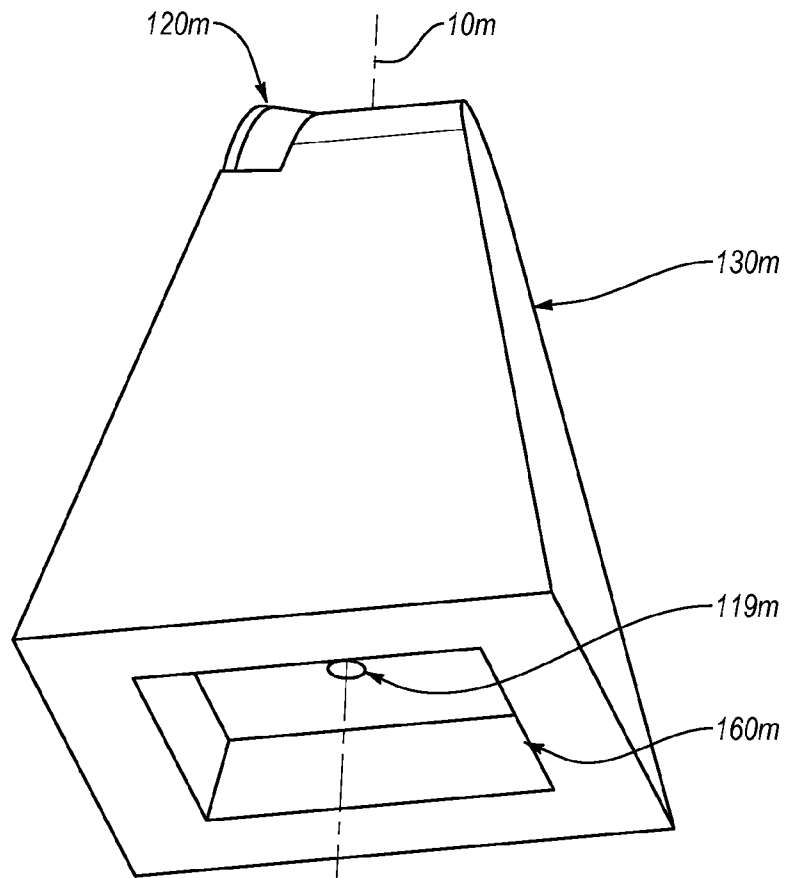

Fig. 5D

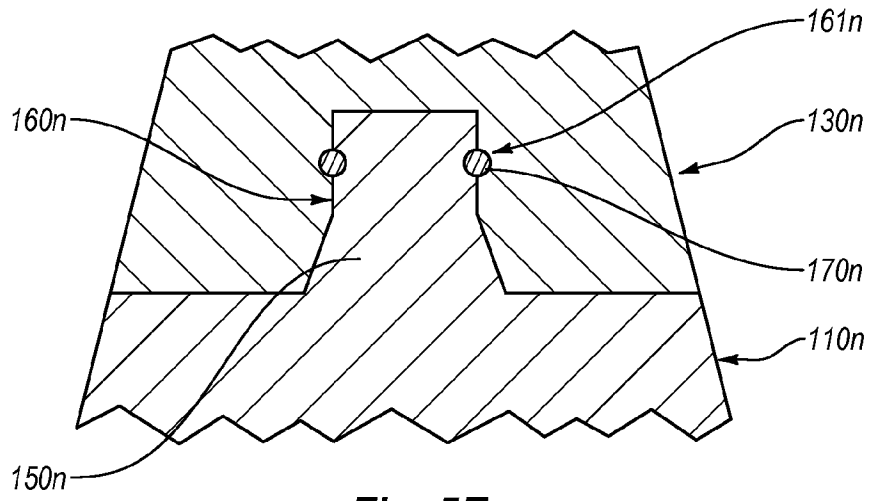

Fig. 5E

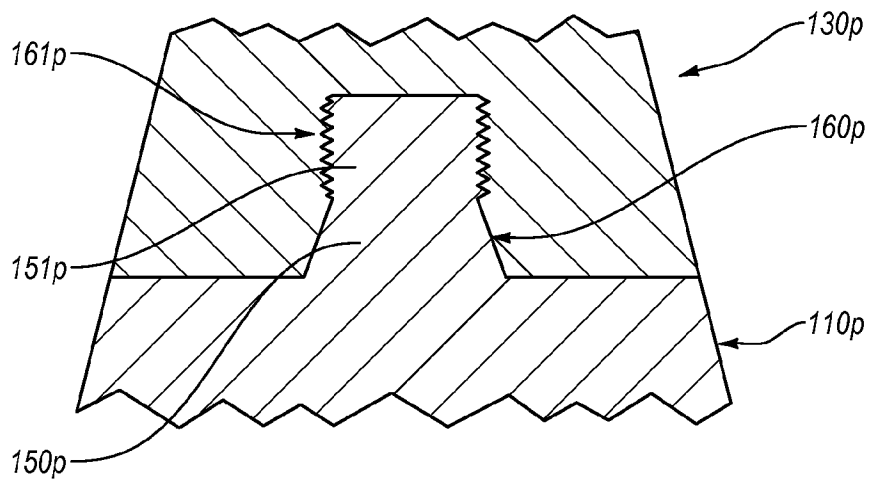

Fig. 5F

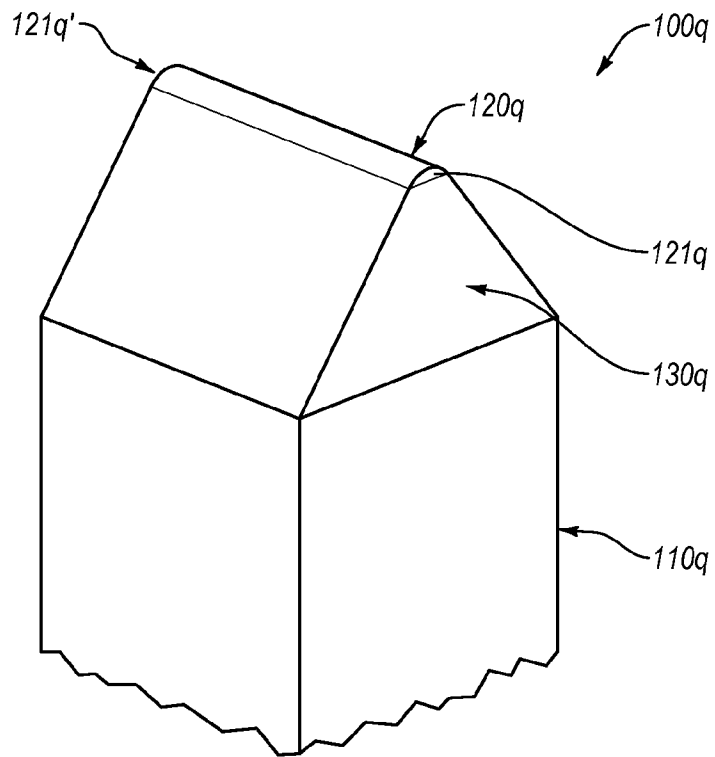

Fig. 6A

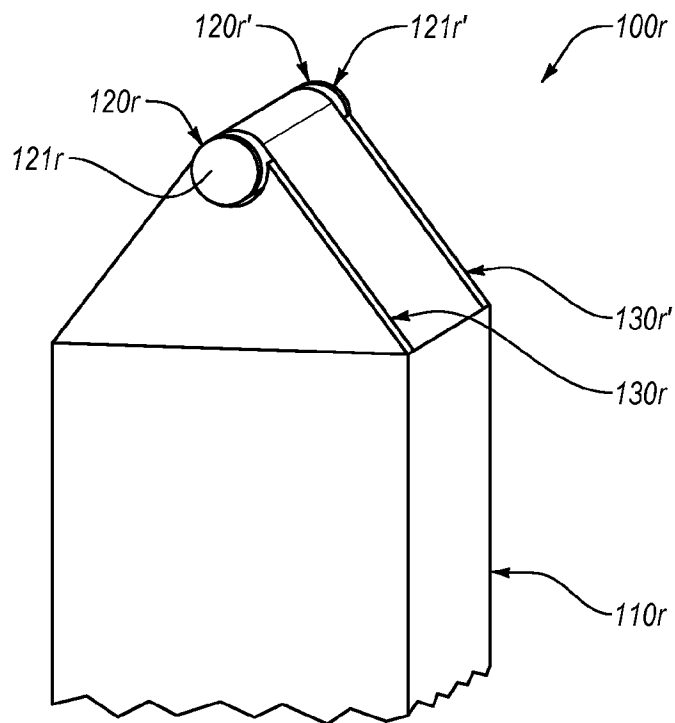

Fig. 6B

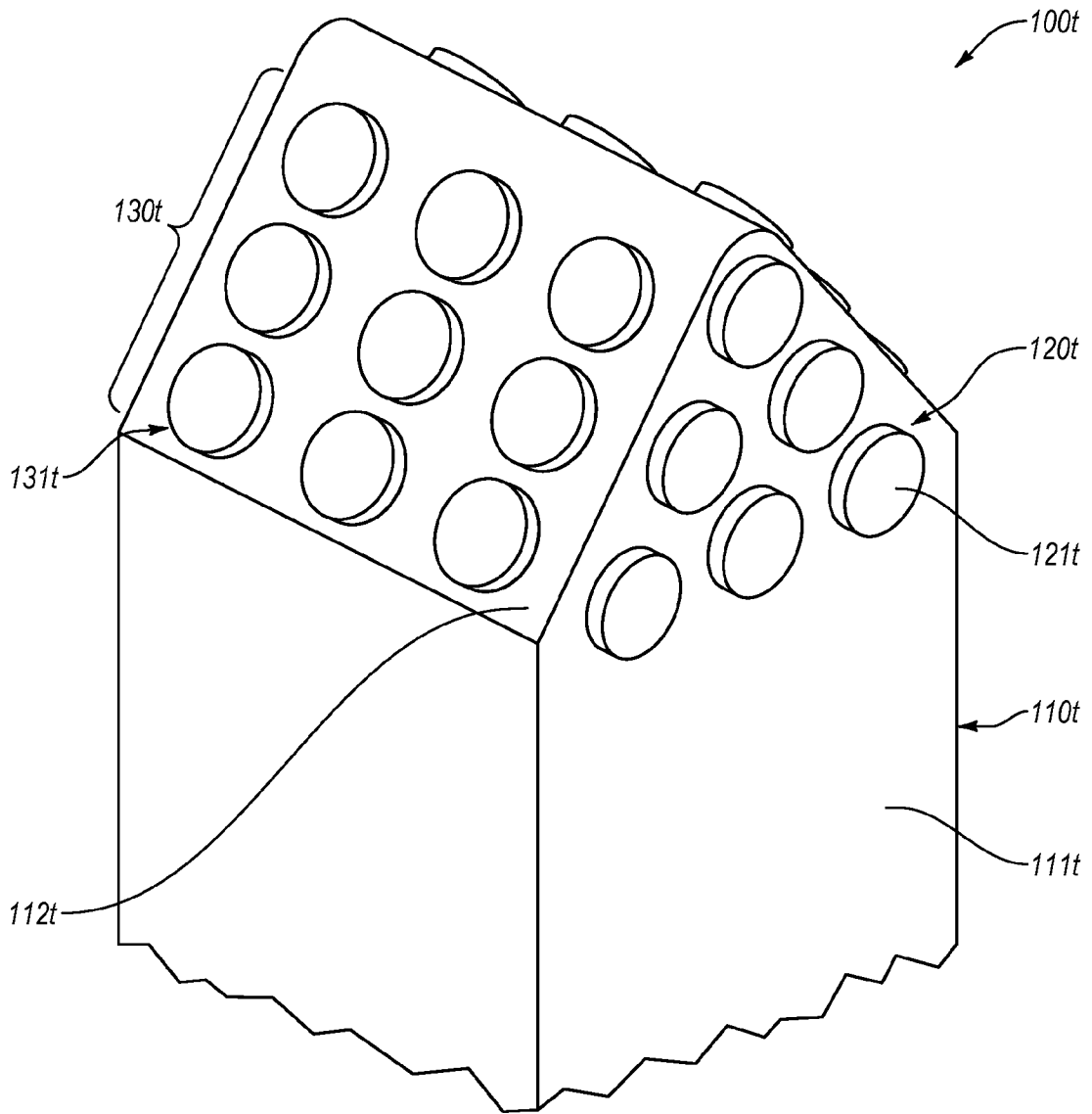

Fig. 7

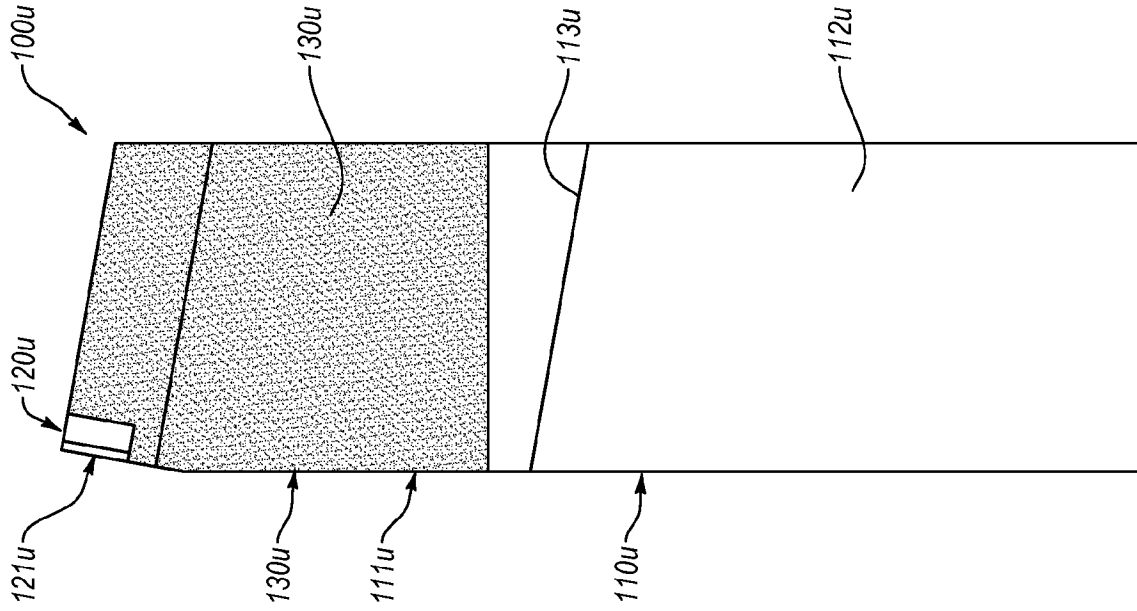

Fig. 8B

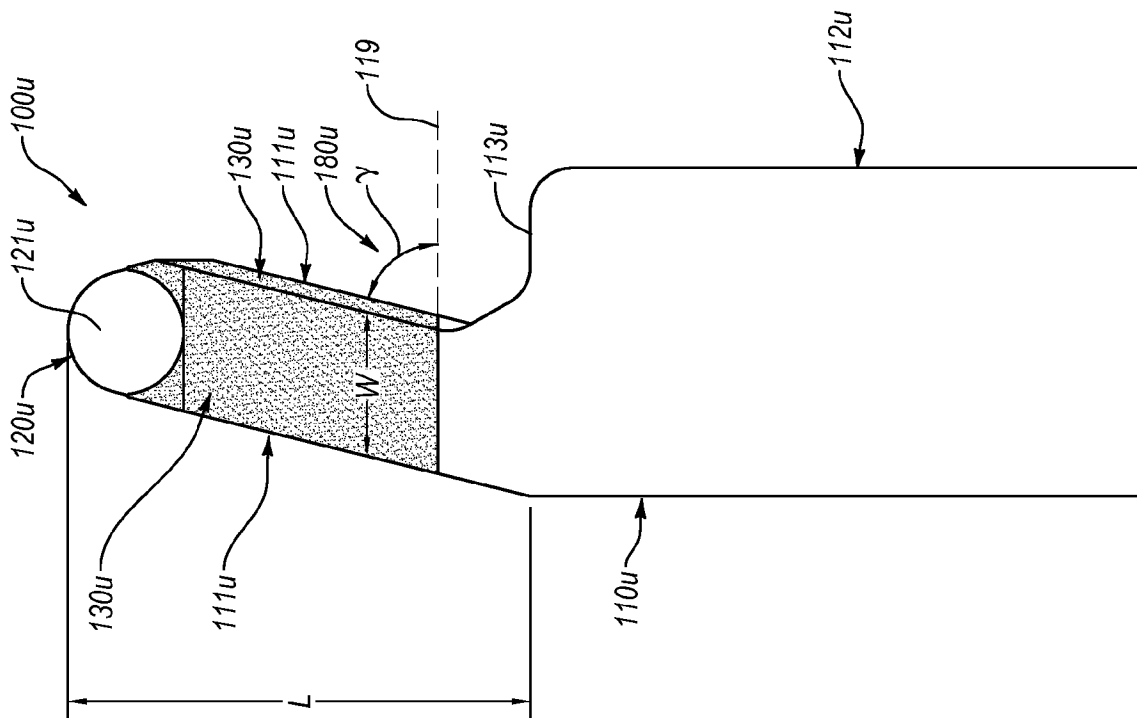

Fig. 8A

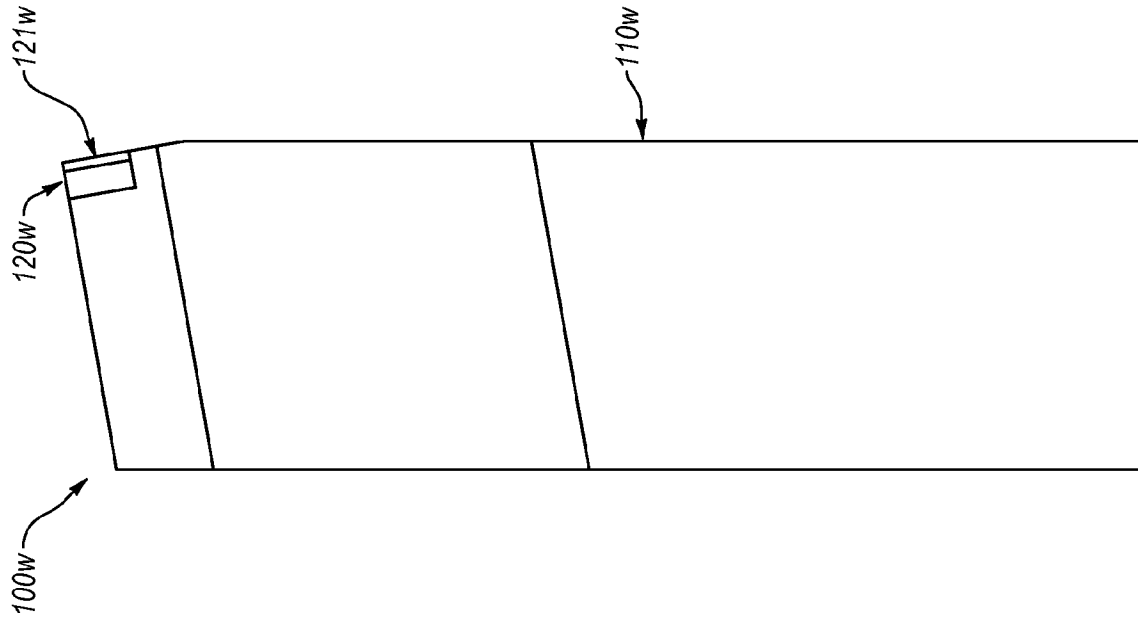

Fig. 8D

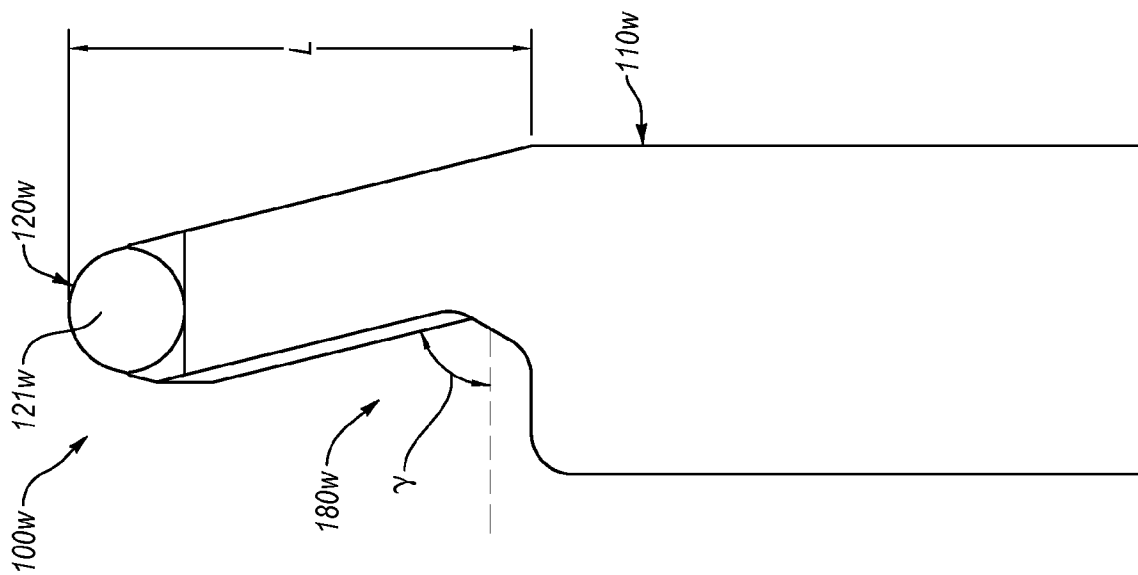

Fig. 8C

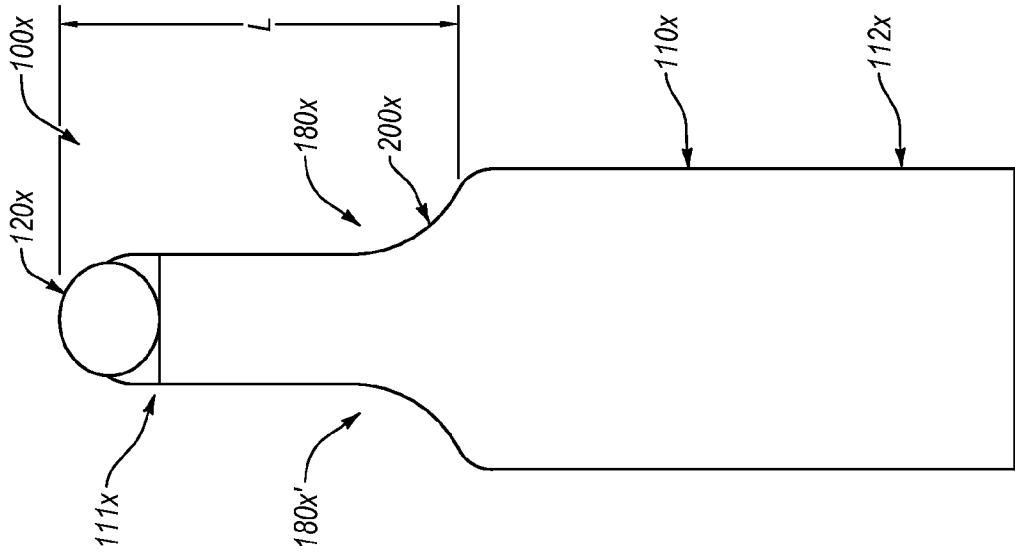

Fig. 8F

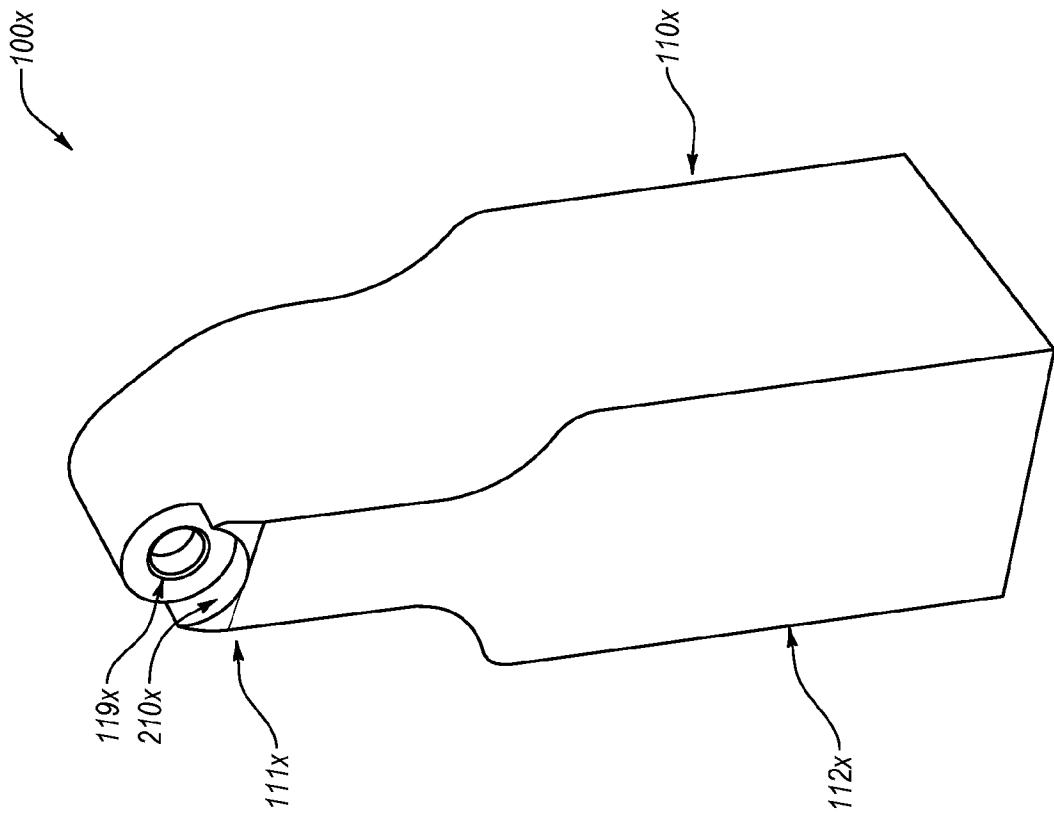

Fig. 8E

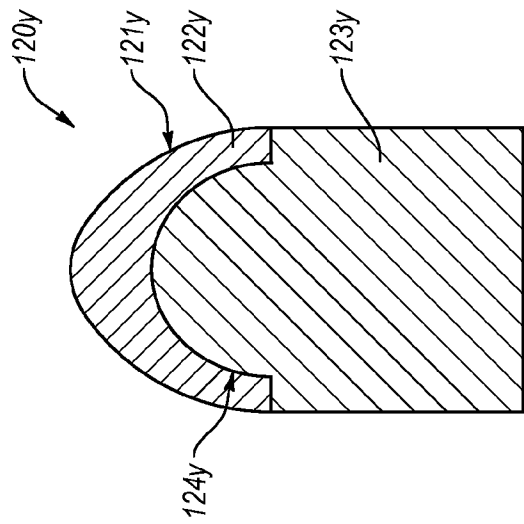

Fig. 9A

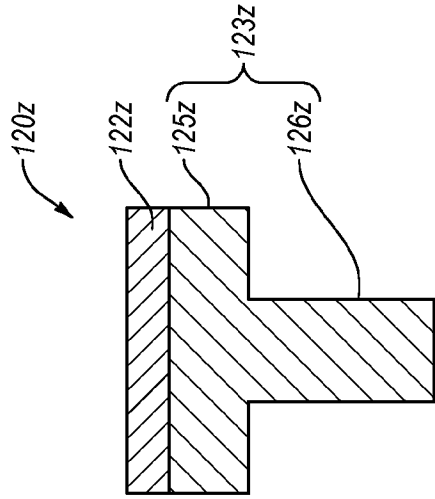

Fig. 9B

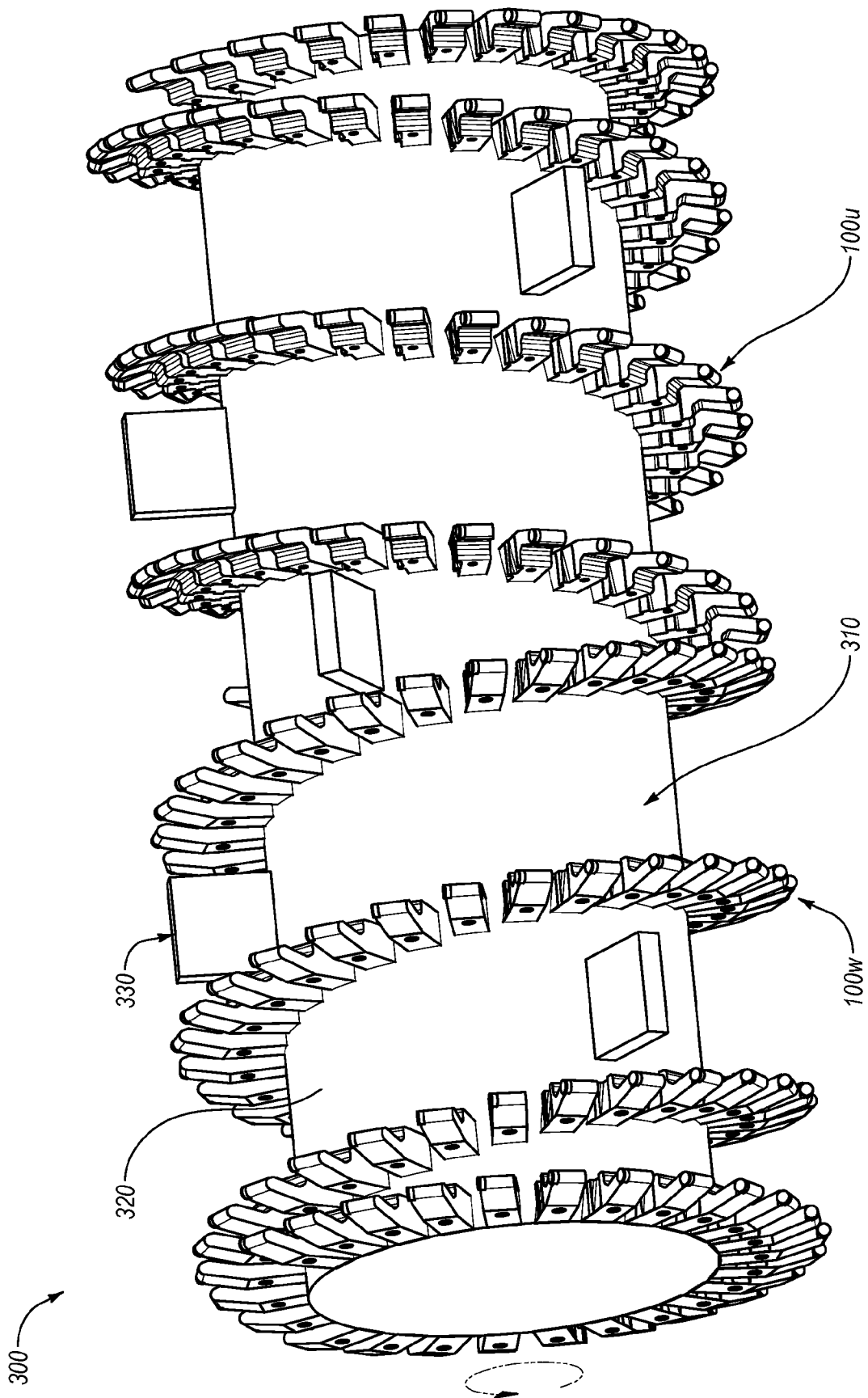

Fig. 10A

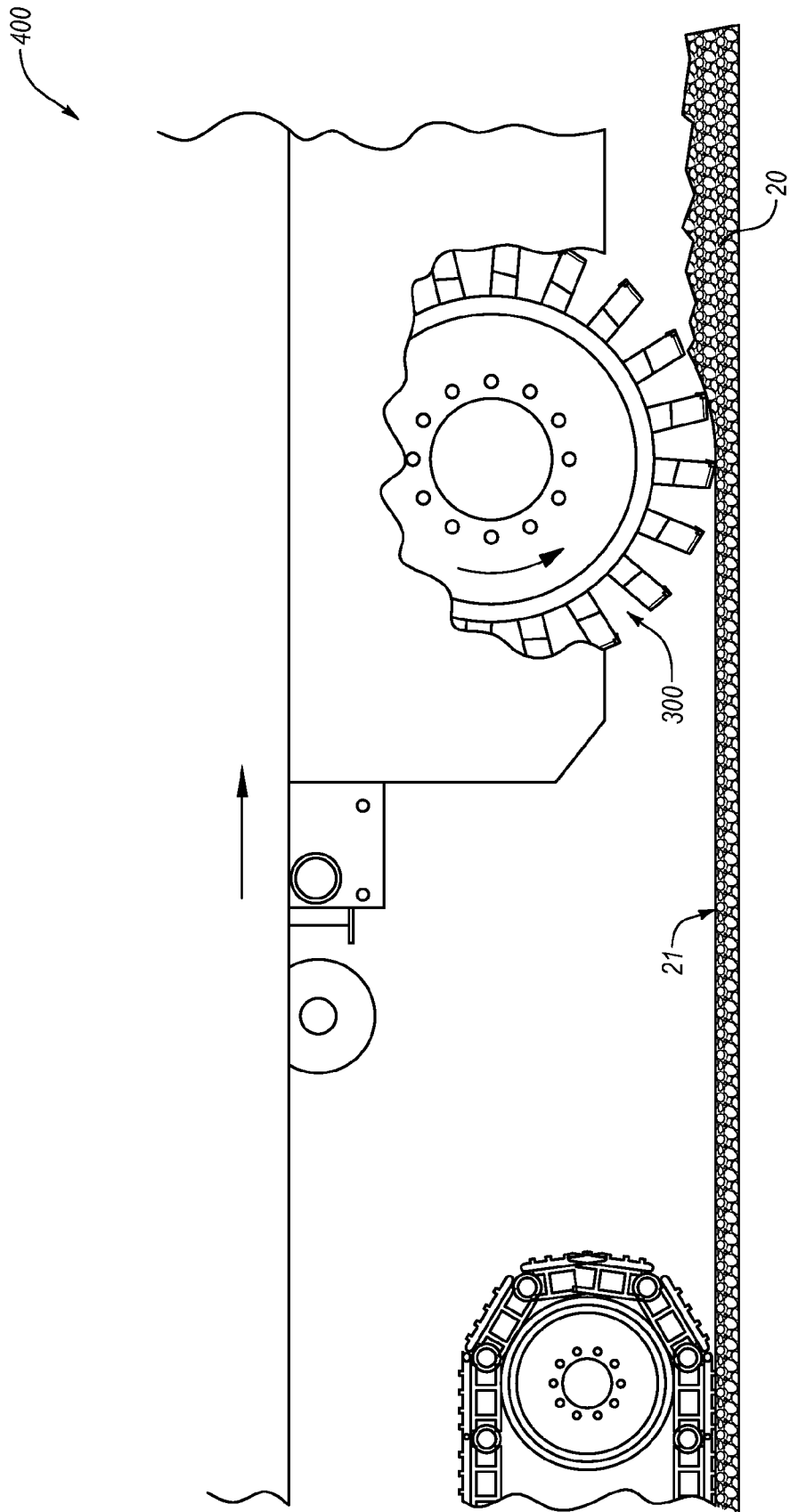

Fig. 10B

INTERNATIONAL SEARCH REPORT

International application No
PCT/US2015/027830

A. CLASSIFICATION OF SUBJECT MATTER
INV. B28D1/18 E21C35/183
ADD.
According to International Patent Classification (IPC) or to both national classification and IPC

B. FIELDS SEARCHED
Minimum documentation searched (classification system followed by classification symbols)
B28D E21C

Documentation searched other than minimum documentation to the extent that such documents are included in the fields searched

Electronic data base consulted during the international search (name of data base and, where practicable, search terms used)
EPO-Internal

C. DOCUMENTS CONSIDERED TO BE RELEVANT

Category*	Citation of document, with indication, where appropriate, of the relevant passages	Relevant to claim No.
X A	CN 202 073 564 U (UNIV SHANDONG) 14 December 2011 (2011-12-14) the whole document -----	1-9,11, 14,15 10,12,13
X A	US 2008/309146 A1 (HALL DAVID R [US] ET AL) 18 December 2008 (2008-12-18) the whole document in particular: paragraph [0018] - paragraph [0021] figures 1,1a -----	1-9,11, 14,15 10,12,13
X A	CN 203 081 445 U (HENAN SF DIAMOND CO LTD) 24 July 2013 (2013-07-24) the whole document ----- -/--	1-7,9, 10,12, 14,15 8,11,13

Further documents are listed in the continuation of Box C.

See patent family annex.

* Special categories of cited documents :

"A" document defining the general state of the art which is not considered to be of particular relevance

"E" earlier application or patent but published on or after the international filing date

"L" document which may throw doubts on priority claim(s) or which is cited to establish the publication date of another citation or other special reason (as specified)

"O" document referring to an oral disclosure, use, exhibition or other means

"P" document published prior to the international filing date but later than the priority date claimed

"T" later document published after the international filing date or priority date and not in conflict with the application but cited to understand the principle or theory underlying the invention

"X" document of particular relevance; the claimed invention cannot be considered novel or cannot be considered to involve an inventive step when the document is taken alone

"Y" document of particular relevance; the claimed invention cannot be considered to involve an inventive step when the document is combined with one or more other such documents, such combination being obvious to a person skilled in the art

"&" document member of the same patent family

Date of the actual completion of the international search 6 July 2015	Date of mailing of the international search report 14/07/2015
--	--

Name and mailing address of the ISA/ European Patent Office, P.B. 5818 Patentlaan 2 NL - 2280 HV Rijswijk Tel. (+31-70) 340-2040, Fax: (+31-70) 340-3016	Authorized officer Rijks, Mark
--	---------------------------------------

INTERNATIONAL SEARCH REPORT

International application No
PCT/US2015/027830

C(Continuation). DOCUMENTS CONSIDERED TO BE RELEVANT		
Category*	Citation of document, with indication, where appropriate, of the relevant passages	Relevant to claim No.
X	GB 1 481 278 A (VETTER W) 27 July 1977 (1977-07-27)	1-5,9-15
A	the whole document in particular: page 2, left-hand column, line 25 - line 29 figure 1	6-8
X	----- AU 2013 101 370 A4 (LIU YUHAI) 14 November 2013 (2013-11-14)	1-9,11, 15
A	the whole document in particular: page 3, line 1 - line 3 figure 1	10,12-14
X	----- WO 2010/083015 A1 (DIAMOND INNOVATIONS INC [US]; SANDVIK INTELLECTUAL PROPERTY [SE]; LUCE) 22 July 2010 (2010-07-22)	1-7, 9-11,15
A	paragraphs [0001], [0004], [0035] figure 1B	8,12-14
X	----- CN 102 108 866 A (LIXIN MIN; HUABO MU) 29 June 2011 (2011-06-29)	1-4,6-9, 11,14,15
A	the whole document	5,10,12, 13
X	----- US 4 605 343 A (HIBBS JR LOUIS E [US] ET AL) 12 August 1986 (1986-08-12)	1-5, 9-11,14, 15
A	column 2, line 24 - line 29 column 4, line 28 - line 47 figures 1,5,6	6-8,12, 13

INTERNATIONAL SEARCH REPORT

Information on patent family members

International application No PCT/US2015/027830

Patent document cited in search report	Publication date	Publication date	Patent family member(s)	Publication date
CN 202073564	U	14-12-2011	NONE	

US 2008309146	A1	18-12-2008	NONE	

CN 203081445	U	24-07-2013	NONE	

GB 1481278	A	27-07-1977	BE 831792 A2	17-11-1975
			DE 2437361 A1	26-02-1976
			FR 2280786 A1	27-02-1976
			GB 1481278 A	27-07-1977

AU 2013101370	A4	14-11-2013	NONE	

WO 2010083015	A1	22-07-2010	AU 2009337061 A1	28-07-2011
			CA 2749003 A1	22-07-2010
			CN 102301092 A	28-12-2011
			EP 2387652 A1	23-11-2011
			RU 2011134051 A	20-02-2013
			US 2010194176 A1	05-08-2010
			WO 2010083015 A1	22-07-2010

CN 102108866	A	29-06-2011	NONE	

US 4605343	A	12-08-1986	CA 1242587 A1	04-10-1988
			US 4605343 A	12-08-1986
