



INTERNATIONAL APPLICATION PUBLISHED UNDER THE PATENT COOPERATION TREATY (PCT)

(51) International Patent Classification ⁷ : A61J 1/00, A61M 5/30	A1	(11) International Publication Number: WO 00/62734 (43) International Publication Date: 26 October 2000 (26.10.00)
---	----	--

(21) International Application Number: PCT/DK00/00176

(22) International Filing Date: 12 April 2000 (12.04.00)

(30) Priority Data:
PA 1999 00509 16 April 1999 (16.04.99) DK(71) Applicant: NOVO NORDISK A/S [DK/DK]; Novo Allé,
DK-2880 Bagsværd (DK).(72) Inventors: BUCH-RASMUSSEN, Thomas; Dalvej 28,
DK-2820 Gentofte (DK). AASMUL, Søren; Borgmester
Schneiders Vej 60, DK-2840 Holte (DK). FLINK, James,
M.; Fuglebakkevej 63, DK-2000 Frederiksberg (DK).
HANSEN, Philip; Skovmindevej 23B, DK-2840 Holte
(DK). JUUL-MORTENSEN, Claus; Junggreensvej 8,
DK-2000 Frederiksberg (DK). POULSEN, Jens, Ulrik;
Virumgade 54C, DK-2830 Virum (DK).(81) Designated States: AE, AG, AL, AM, AT, AU, AZ, BA, BB,
BG, BR, BY, CA, CH, CN, CR, CU, CZ, DE, DK, DM,
DZ, EE, ES, FI, GB, GD, GE, GH, GM, HR, HU, ID, IL,
IN, IS, JP, KE, KG, KP, KR, KZ, LC, LK, LR, LS, LT, LU,
LV, MA, MD, MG, MK, MN, MW, MX, NO, NZ, PL, PT,
RO, RU, SD, SE, SG, SI, SK, SL, TJ, TM, TR, TT, TZ,
UA, UG, UZ, VN, YU, ZA, ZW, ARIPO patent (GH, GM,
KE, LS, MW, SD, SL, SZ, TZ, UG, ZW), Eurasian patent
(AM, AZ, BY, KG, KZ, MD, RU, TJ, TM), European patent
(AT, BE, CH, CY, DE, DK, ES, FI, FR, GB, GR, IE, IT,
LU, MC, NL, PT, SE), OAPI patent (BF, BJ, CF, CG, CI,
CM, GA, GN, GW, ML, MR, NE, SN, TD, TG).**Published***With international search report.**Before the expiration of the time limit for amending the
claims and to be republished in the event of the receipt of
amendments.*

(54) Title: CASSETTE FOR STORING AND INSERTION OF SOLID MEDICINE

(57) Abstract

A cassette for storing and insertion of a solid medicine peg appears as a unit having a first bore (2) which accommodates the medicine peg (3) and has a diameter corresponding to the diameter of this peg (3), a second bore (4) in coaxial extension of the first bore (2) and having a diameter larger than the diameter of the first bore (2), an inserter having a shaft (5) fitting into the first bore (2) and a guiding head (6) in coaxial extension of the shaft (5) fitting into the second bore. The inserter shaft (5) has one end adjacent to the peg (3) and the other connected to the guiding head (6) which projects from the cassette. The head (6) fits into the second bore with a fitting providing a diffusion tight sealing and the distal end of the unit is closed by a membrane diffusion tightly sealing this distal end.

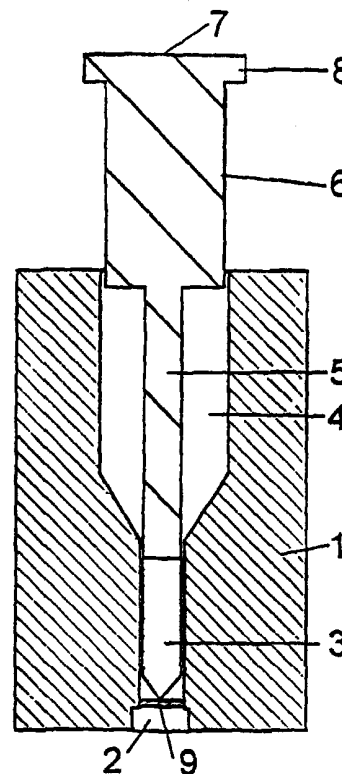

FOR THE PURPOSES OF INFORMATION ONLY

Codes used to identify States party to the PCT on the front pages of pamphlets publishing international applications under the PCT.

AL	Albania	ES	Spain	LS	Lesotho	SI	Slovenia
AM	Armenia	FI	Finland	LT	Lithuania	SK	Slovakia
AT	Austria	FR	France	LU	Luxembourg	SN	Senegal
AU	Australia	GA	Gabon	LV	Latvia	SZ	Swaziland
AZ	Azerbaijan	GB	United Kingdom	MC	Monaco	TD	Chad
BA	Bosnia and Herzegovina	GE	Georgia	MD	Republic of Moldova	TG	Togo
BB	Barbados	GH	Ghana	MG	Madagascar	TJ	Tajikistan
BE	Belgium	GN	Guinea	MK	The former Yugoslav Republic of Macedonia	TM	Turkmenistan
BF	Burkina Faso	GR	Greece	ML	Mali	TR	Turkey
BG	Bulgaria	HU	Hungary	MN	Mongolia	TT	Trinidad and Tobago
BJ	Benin	IE	Ireland	MR	Mauritania	UA	Ukraine
BR	Brazil	IL	Israel	MW	Malawi	UG	Uganda
BY	Belarus	IS	Iceland	MX	Mexico	US	United States of America
CA	Canada	IT	Italy	NE	Niger	UZ	Uzbekistan
CF	Central African Republic	JP	Japan	NL	Netherlands	VN	Viet Nam
CG	Congo	KE	Kenya	NO	Norway	YU	Yugoslavia
CH	Switzerland	KG	Kyrgyzstan	NZ	New Zealand	ZW	Zimbabwe
CI	Côte d'Ivoire	KP	Democratic People's Republic of Korea	PL	Poland		
CM	Cameroon	KR	Republic of Korea	PT	Portugal		
CN	China	KZ	Kazakstan	RO	Romania		
CU	Cuba	LC	Saint Lucia	RU	Russian Federation		
CZ	Czech Republic	LI	Liechtenstein	SD	Sudan		
DE	Germany	LK	Sri Lanka	SE	Sweden		
DK	Denmark	LR	Liberia	SG	Singapore		
EE	Estonia						

Cassette for storing and insertion of solid medicine

The invention relates to units for storing and insertion of solid medicine pegs

- 5 Many types of medicine is given as solutions or suspensions of a medical active substance which are subcutaneously or intramuscularly administered.

Many advantages are obtained if the solid medicine instead of being dissolved or suspended is formed as small needle shaped pegs which are inserted directly into the tissue
10 where they are then dissolved in the tissue fluids and this way administered in the body. Such pegs can be given a size which is comparable with the size of the needle which is used for the injection of the corresponding fluid medicine. As the medicine itself is the needle, no used needles shall be disposed of after the insertion and consequently the risk of accidental needle scratch is eliminated. Further most medicine has a longer shelf life in a solid state
15 than in a solution.

A problem by the solid medicament pegs is their size. As they have to be sufficiently thin to be comparable with an injection needle their thickness is about 1 mm or less and to ensure a deposition in the subcutaneous layer of the skin they have to be short, preferably in the interval 1 - 10 mm. Such sizes can hardly be handled without a tool such as a pincer and even
20 with a pincer the handling is difficult especially for sight impaired people.

It is an object of the invention to provide means for storage and insertion of solid medicine
25 pegs.

From WO 96/08289 is known a disposable device loaded with one medicine peg which can be inserted into the skin by the device. Whereas such a device is acceptable for the insertion of pegs of a medicament which shall be taken once in a while, it is less convenient for medicaments such as insulin which shall be taken frequently as the user has to bring with him a
30 number of devices corresponding to the number of doses he is going to take during the time he is away from his home. Diabetics will prefer a device by which single pegs can be inserted from a cassette in which a number of such pegs are stored.

WO 96/08289 also describes a device which by pressurised air accelerates peg from a cassette through a barrel to shoot it into the skin. As it is important for diabetics that the medicament is inserted subcutaneous the device by which the peg is by a plunger followed to its subcutaneous position is preferred as being more precise than a shooting device.

5

Further in the device according to WO 96/08289 no attention has been paid to the fact that the medicament is biodegradable and have to be kept absolutely dry until it is implanted, i.e. the implant have to be stored in a vessel which is diffusion tightly sealed.

10

Instead of the device in WO 96/08289 by which the user presses the peg through the skin a device is preferred by which the medicine implant by an impact is moved to its subcutaneous position. Such a device may comprise a socket for a cassette with medicine pegs and a hammer which can against the force of a spring be brought to a cocked position from which it can be released to return and hit an anvil from which the impact is transmitted to the medicine peg.

15

An object of the invention is to provide a cassette loaded with pegs for use in such an insertion device.

20

A cassette for storing and insertion of solid medicine is according to the invention characterised in that it comprises at least one unit having a first bore accommodating a medicine peg and having a diameter corresponding to the diameter of this peg, a second bore in coaxial extension of the first bore and having a diameter larger than the diameter of the first bore, an inserter comprising an inserter shaft which fits into the first bore and a guiding head connected to the inserter shaft in coaxial extension of this inserter shaft and fitting into the second bore, the inserter shaft having a distal end adjacent to a proximal end of the peg and a proximal end connected to a distal end of the guiding head, which guiding head forms at its proximal end an anvil, the second bore having a length so that the distal end of the inserter shaft is moved to a position extending over the distal end of the housing a distance corresponding to a wanted insertion depth for the when the distal end of the guiding head is moved to the bottom of the second bore.

25

30

As the shaft is very thin it is important that the impact force which is transmitted through this shaft is strictly axial as a skew force may cause the shaft to bend. The guiding head sliding

through the second bore will compensate a possible skew impact on the anvil end of the guiding head so that only an axial force is transmitted to the shaft. The shaft must only have a length corresponding to the distance which the peg has to be moved to be passed from its position in the first bore to its position in the tissue in which it is inserted. Keeping the shaft
5 as short as possible further minimises the risk for bending.

According to the invention the medicine peg may be moulded in the first bore. This way handling of the small peg is made easier and it is guaranteed that the diameter of the peg corresponds to the inner diameter of said first bore.

10

The head of the inserter may fit into the second bore with a fitting making the head provide a diffusion tight sealing of the proximal end of the second bore, and the distal end of the first bore may be closed by a membrane diffusion tightly sealing the distal end of the unit. This enables a sterile storage of the individual pegs until they are inserted. The membrane is
15 weakened to make it burst in a controlled way not to leave debris of the membrane when the peg is forced through it.

The membrane may be formed integral with the material of the cassette or it may be applied as a separate member, e. g. a metal foil covering the opening of the distal end of the first
20 bore, or it may be embedded in the cassette material adjacent to the distal end of the first bore.

To ease the mounting of an inserter in a unit the transition from the second bore to the first bore may be made funnel shaped.

25

The guiding head of the inserter may appropriately have a length ensuring that the anvil end of this guiding head projects from the proximal end of the cassette when an impact on the anvil has moved the peg to its wanted position in the skin of a user. As the proximal end of the peg must be placed a distance under the skin, the distal end of the shaft pushing the peg
30 must be moved to a position in which it projects a corresponding distance from the distal end of the unit. The anvil end of the guiding head may be provided with a flange which can be engaged by a draw out mechanism in the not shown insertion device which draw out mechanism can after an insertion of a peg draw the inserter back to hide the distal end of the inserter shaft in the first bore when the peg stored in that bore has been inserted.

The drawing back of the inserter may be accomplished in other ways, e. g. by use of a coil spring surrounding the shaft between the distal end of the guiding head and the bottom of the second bore. Alternatively the compression of the air in the space between the distal end
5 of the guiding head and the bottom of the second bore can be relied on as a means for moving backwards the inserter after it has by an impact on the anvil been moved in a distal direction to insert a peg.

In the cassette the array of units may form a beam, which can be moved by the insertion apparatus so that a new unit is moved to an insertion position each time the hammer mechanism has caused insertion of the peg in the unit which is at the moment placed in the insertion position.
10

The cassettes may be provided with guiding projections or indentions to ensure their correct guiding through and positioning in the insertion device
15

In the following the invention is further described with references to the drawing, wherein

Figure 1 shows schematically a sectional view through an insert unit,
20

Figure 2 shows a sectional view of a part of a beam shaped insert unit cassette with inserter units in different conditions.

The insert unit in figure 1 comprises a housing 1 with a first bore 2 having a diameter corresponding to the diameter of a peg positioned in said first bore 1 which opens through a first end of the housing . The peg 3 is made from the effective drug which shall be injected and which drug may be mixed with a bio-compatible binder to give the peg a sufficient strength to penetrate the skin without crushing. A second bore 4 in axial extension of the first bore 2 has a larger diameter than this first bore and opens through a second end of the housing 1. An
25 inserter comprises an inserter shaft 5 having a diameter corresponding to the diameter of the peg 3, and a guiding head 6 having a diameter corresponding to the diameter of the second bore 4. The inserter shaft 5 and the inserter head 6 are connected to each other and lies in axial extension of each other. A free end of the inserter shaft 5 is inserted in the first bore 2 adjacent to the peg 3. The other end of the shaft 5 is coupled to the guiding head 6 and has
30

a length which ensures that a part of the guiding head is inserted in the end of the second bore 4 opening through the second end of the housing 1. The length of the second bore 4 is so adapted that the free end of the inserter projects over the first end of the housing when the end of the guiding head inserted in the second bore 4 is moved to the bottom of this bore. The length of the guiding head is so adapted that its outer end still projects over the second end of the housing 1 when its inner end reaches the bottom of the second bore 4. The end surface of the outer end of the guiding head 6 forms an anvil 7, which can be impacted by a hammer mechanism in a not shown insert device. The outer end of the guiding head 6 is provided with a flange 8 which can be engaged by a withdraw mechanism in the not shown insert device to draw the inserter back from its position with the end of the inserter shaft 5 projecting from the first end of the housing 1.

In the shown embodiment of the inserter unit the transition zone between the first 2 and the second 4 bore is funnel shaped to ease the mounting of the inserter with the free end of its shaft guided in the first bore 2. The peg 3 is pointed at the end which shall penetrate the skin to make this penetration easier. The pointed end has the shape of a cone with a apex angle in the interval 30° to 90° preferably between 50° - 70° The end of the first bore 2 from which the peg 3 is pushed into the skin is closed by a membrane 9 which can be integral with the housing or be a metal foil embedded in the material of the housing. In the shown embodiment this membrane lies inside the first bore in a distance from the opening of this bore. Over this distance the first bore is given a slightly enlarged diameter to make room for flaps of the membrane, which are formed when the membrane 9 is penetrated by the peg 3.

Cassettes comprising more units can be shaped as beams, cylinders or bands which can be mounted in an insertion mechanism in which the cassette is advanced to place a unused unit in an insertion position in which a hammer can be released to hit the anvil of the unit in question to move the peg out of the housing into the skin. Before use the peg is stored sterilely in the housing, the bore through which the peg is delivered being covered by a diffusion tight membrane and the other end with the wider second bore being closed by the inserter head fitting with a press fitting into this second bore. For the insertion of medicaments of which only one dose is needed, so as glucagon, adrenaline or atropine, a single cassette may be used whereas implantation of medicaments, which have to be applied frequently, such as insulin or growth hormone, an array of more units is preferred. The units may be arrayed on line in a beam shaped cassette or in a revolver drum shaped cassette or a number of single

cassettes may be designed to be hinged together to form a cartridge belt. The choice of design may depend on the number of units, which shall be arrayed.

Figure 2 shows a part of a beam with three insertion units. The first unit 11 is shown in a position wherein the inserter is shown in the position it has after insertion of the peg and after the inserter is drawn back from its position with the end of the inserter shaft projecting over the first end of the housing. The unit 12 is shown in the position immediately after an impact on the anvil 7 in which position the end of the inserter shaft is still projecting from the first side of the housing. Finally the unit 13 is in the storing position where it has not yet been operated. The first end of the units 11, 12 and 13 are covered by a foil 10 which is sealed to the surface formed by the first ends of the integral housings of the units. The foil 10 may be made from metal, plastic or laminates of different types of plastic or of metal and plastic.

Claims

1. Cassette for storing and insertion of solid medicine peg characterised in that it comprises at least one unit having a first bore (2) accommodating the medicine peg (3) and having a diameter corresponding to the diameter of this peg (3), a second bore (4) in coaxial extension of the first bore (2) and having a diameter larger than the diameter of the first bore (2), an inserter comprising an inserter shaft (5) fitting into the first bore (2) and a guiding head (6) connected to the inserter shaft (6) in coaxial extension of this inserter shaft and fitting into the second bore, the inserter shaft (5) having a distal end adjacent to a proximal end of the peg (3) and a proximal end connected to a distal end of the guiding head (6) which forms at its proximal end an anvil (7), the second bore (4) having a length so that the distal end of the inserter shaft (5) is moved to a position extending over the distal end of the housing a distance corresponding to a wanted insertion depth for the peg when the distal end of the guiding head is moved to the bottom of the second bore.
- 2 A cassette according to claim 1, characterised in that the medicine peg is moulded in the first bore
3. A cassette according to claim 1 or 2, characterised in that the head (6) of the inserter fits into the second bore with a press fitting which provides a diffusion tight sealing of the proximal end of the unit, and that the distal end of the unit is closed by a membrane diffusion tightly sealing the distal end of the unit.
4. A cassette according to according to claim 1, 2 or 3, characterised in that the cassette comprises a number of integral units arrayed in a beam of the housing material.
5. A cassette according to claim 1, 2 or 3 implant, characterised in that the cassette comprises a number of integral units arrayed along the periphery of a drum.
6. A cassette according to claim 1, 2 or 3, characterised in that the cassette comprises a number of single unit cassettes hinged together to form a cartridge band.

1/1

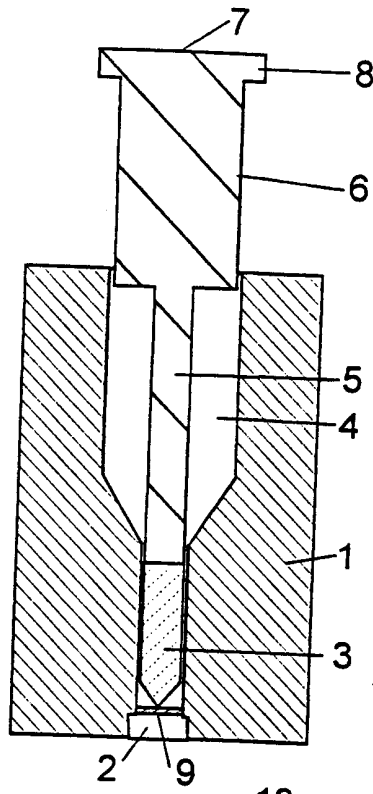

Fig. 1

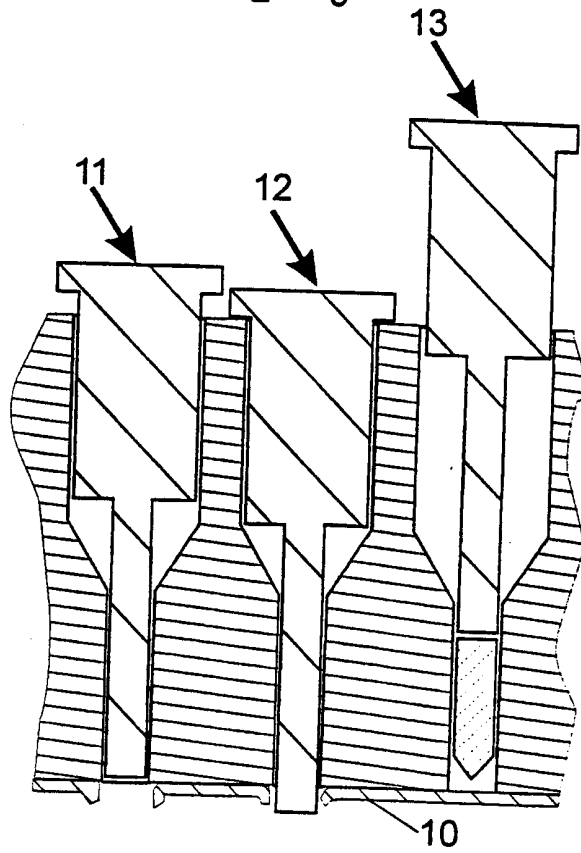

Fig. 2

INTERNATIONAL SEARCH REPORT

International application No.

PCT/DK 00/00176

A. CLASSIFICATION OF SUBJECT MATTER

IPC7: A61J 1/00, A61M 5/30

According to International Patent Classification (IPC) or to both national classification and IPC

B. FIELDS SEARCHED

Minimum documentation searched (classification system followed by classification symbols)

IPC7: A61J, A61M

Documentation searched other than minimum documentation to the extent that such documents are included in the fields searched

SE,DK,FI,NO classes as above

Electronic data base consulted during the international search (name of data base and, where practicable, search terms used)

EPODOC, WPI

C. DOCUMENTS CONSIDERED TO BE RELEVANT

Category*	Citation of document, with indication, where appropriate, of the relevant passages	Relevant to claim No.
A	US 5021241 A (YOSHIYA YAMAHIRA ET AL), 4 June 1991 (04.06.91), figures 1-6, claims 1-23 --	1-6
A	US 4576591 A (GORDON E. KAYE ET AL), 18 March 1986 (18.03.86), figures 1-15, claims 1-3 --	1-6
A	WO 9323110 A1 (VAN DE WIJDEVEN), 25 November 1993 (25.11.93), figures 1-3, claims 1-17 --	1-6
A	WO 9422423 A1 (BUKH MEDITEC A/S), 13 October 1994 (13.10.94), figures 1-4, claims 1-60 --	1-6

 Further documents are listed in the continuation of Box C. See patent family annex.

* Special categories of cited documents:

"A" document defining the general state of the art which is not considered to be of particular relevance

"E" earlier document but published on or after the international filing date

"L" document which may throw doubts on priority claim(s) or which is cited to establish the publication date of another citation or other special reason (as specified)

"O" document referring to an oral disclosure, use, exhibition or other means

"P" document published prior to the international filing date but later than the priority date claimed

"T" later document published after the international filing date or priority date and not in conflict with the application but cited to understand the principle or theory underlying the invention

"X" document of particular relevance: the claimed invention cannot be considered novel or cannot be considered to involve an inventive step when the document is taken alone

"Y" document of particular relevance: the claimed invention cannot be considered to involve an inventive step when the document is combined with one or more other such documents, such combination being obvious to a person skilled in the art

"&" document member of the same patent family

Date of the actual completion of the international search

22 August 2000

Date of mailing of the international search report

24 -08- 2000

Name and mailing address of the ISA/
Swedish Patent Office
Box 5055, S-102 42 STOCKHOLM
Facsimile No. +46 8 666 02 86

Authorized officer

Agneta Ånggård/Els
Telephone No. +46 8 782 25 00

INTERNATIONAL SEARCH REPORT

International application No.

PCT/DK 00/00176

C (Continuation). DOCUMENTS CONSIDERED TO BE RELEVANT

Category*	Citation of document, with indication, where appropriate, of the relevant passages	Relevant to claim No.
A	WO 9608289 A1 (SOCIETE DE CONSEILS DE RECHERCHES ET D'APPLICATIONS SCIENTIFIQUES, S.A.), 21 March 1996 (21.03.96), figures 1-5, claims 1-24 -- -----	1-6

INTERNATIONAL SEARCH REPORT
Information on patent family members

International application No.
PCT/DK 00/00176

Patent document cited in search report			Publication date	Patent family member(s)		Publication date
US	5021241	A	04/06/91	AU	587443 B	17/08/89
				JP	1928128 C	12/05/95
				JP	6057658 B	03/08/94
				JP	61236729 A	22/10/86
				MX	169334 B	30/06/93
				NZ	215730 A	30/03/88
				US	4774091 A	27/09/88
				US	5385738 A	31/01/95
				DE	3484584 D	00/00/00
				DE	3484951 A	26/09/91
				DE	3486029 A	18/02/93
				EP	0138216 A,B	24/04/85
				SE	0138216 T3	
				EP	0139286 A,B	02/05/85
				SE	0139286 T3	
				EP	0140255 A,B	08/05/85
				SE	0140255 T3	
				JP	60084213 A	13/05/85
				US	4855134 A	08/08/89
				US	5081156 A	14/01/92
				JP	1713509 C	27/11/92
				JP	3072046 B	15/11/91
				JP	60097918 A	31/05/85
				JP	2010103 C	02/02/96
				JP	5071566 B	07/10/93
				JP	60126217 A	05/07/85
				JP	60227772 A	13/11/85
				JP	60129057 A	10/07/85

US	4576591	A	18/03/86	US	4531938 A	30/07/85

WO	9323110	A1	25/11/93	AU	677203 B	17/04/97
				AU	4358993 A	13/12/93
				CA	2134770 A	25/11/93
				EP	0686053 A	13/12/95
				JP	7509622 T	26/10/95
				NL	9200844 A	01/12/93
				US	5549560 A	27/08/96

WO	9422423	A1	13/10/94	AU	6534894 A	24/10/94

INTERNATIONAL SEARCH REPORT

Information on patent family members

International application No.

PCT/DK 00/00176

Patent document cited in search report	Publication date	Patent family member(s)	Publication date
WO 9608289 A1	21/03/96	AT 173941 T	15/12/98
		AU 705266 B	20/05/99
		AU 3531595 A	29/03/96
		AU 4454299 A	21/10/99
		BR 9508830 A	03/11/98
		CA 2199516 A	21/03/96
		DE 69506428 D,T	02/06/99
		EP 0782465 A,B	09/07/97
		SE 0782465 T3	
		ES 2125657 T	01/03/99
		JP 10505526 T	02/06/98
		US 5542920 A	06/08/96
