



US 20090039598A2

(19) **United States**
(12) **Patent Application Publication**
Shigeta

(10) **Pub. No.: US 2009/0039598 A2**
(43) **Pub. Date: Feb. 12, 2009**
REPUBLICATION

(54) **CARD READING DEVICE**

(30) **Foreign Application Priority Data**

(75) Inventor: **Yasushi Shigeta**, Osaka (JP)

Mar. 19, 2004 (JP) 2004-079519

Correspondence Address:
AMSTER, ROTHSTEIN & EBENSTEIN LLP
90 PARK AVENUE
NEW YORK, NY 10016 (UNITED STATES)

Publication Classification

(51) **Int. Cl.**
A63F 1/06 (2006.01)
(52) **U.S. Cl.** **273/148 R**

(73) Assignee: **Angel Co., Ltd.**, Osaka (JP)

(57) **ABSTRACT**

(21) Appl. No.: **11/884,021**

A card reader includes a platform, a card shooter mounted on the platform, and a card guide unit. The card guide unit guides cards which are pulled out one by one from the card shooter. One or more black light sensors are provided in the card guide unit to read an ultraviolet-ray reaction code from a card guided by the card guide unit, the ultraviolet-ray reaction code on the card indicating at least the number the card.

(22) Filed: **Aug. 9, 2007**

Prior Publication Data

(65) US 2008/0224394 A1 Sep. 18, 2008

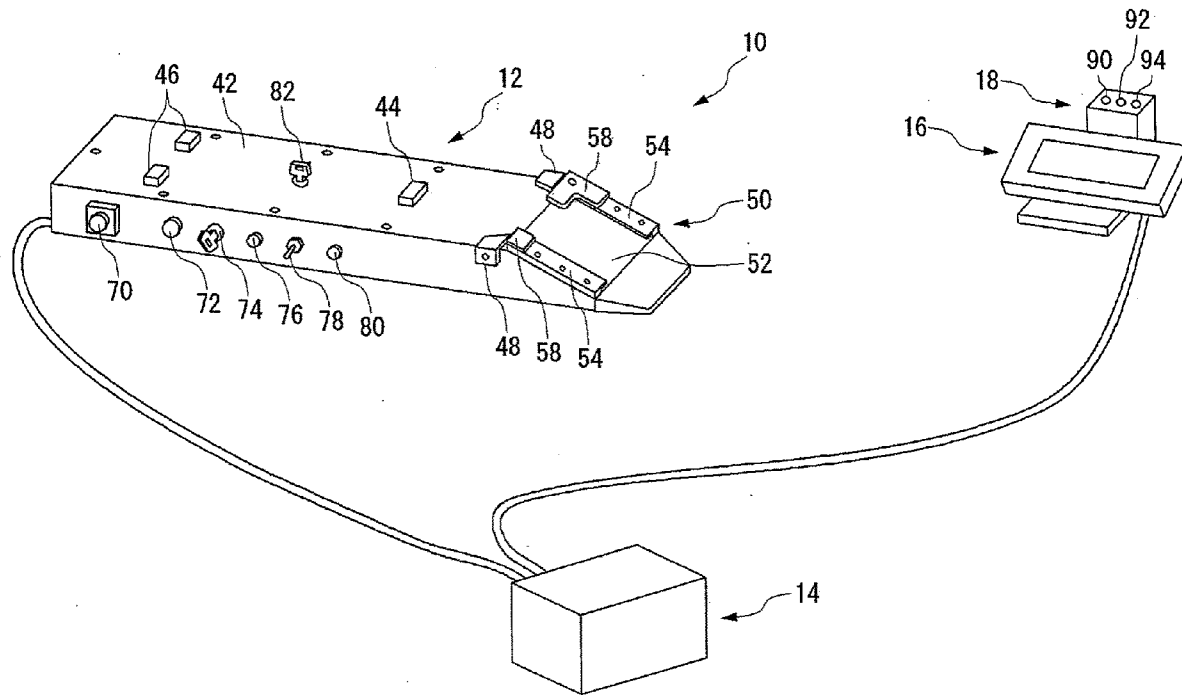

FIG. 1

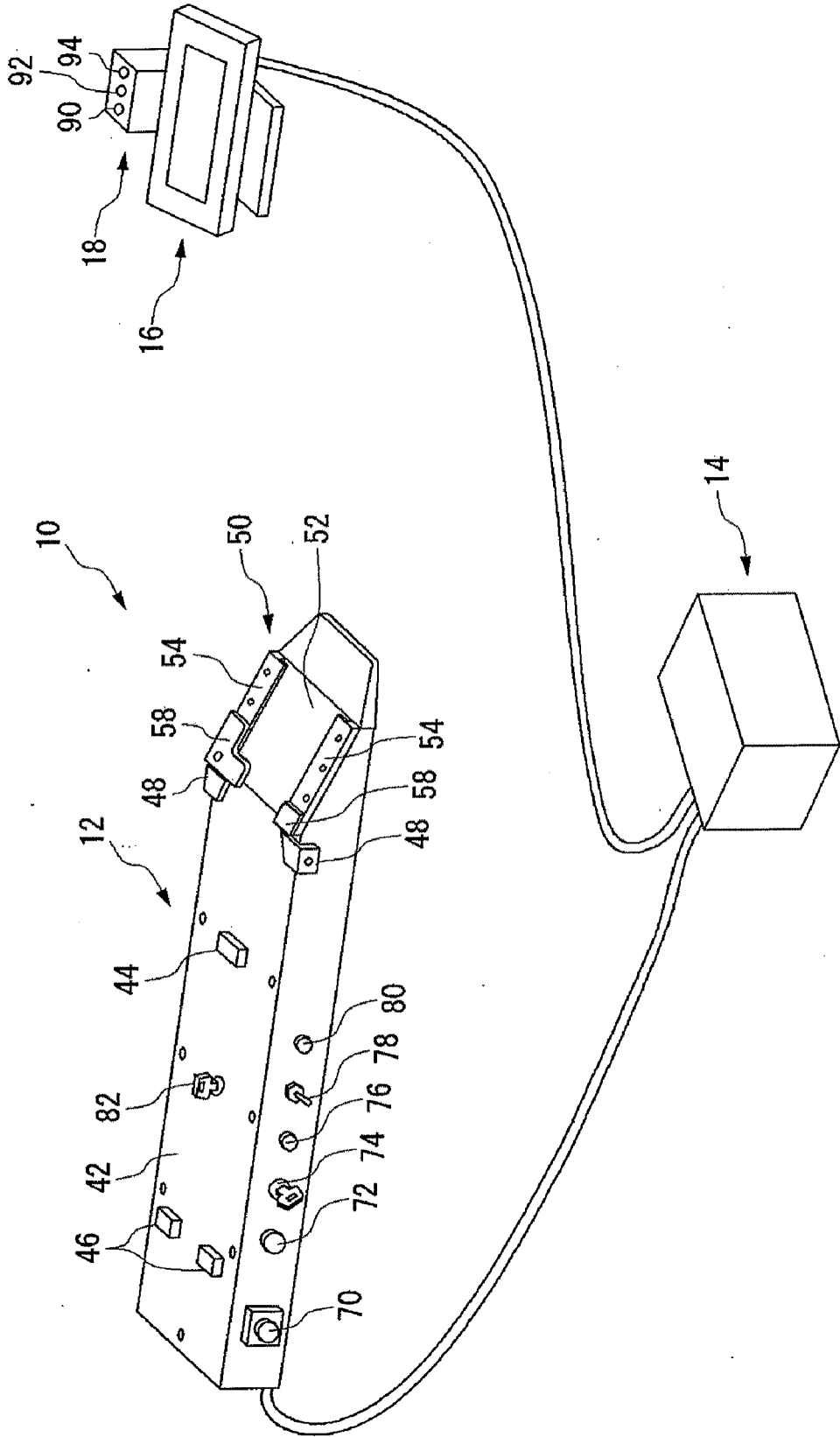

FIG. 2

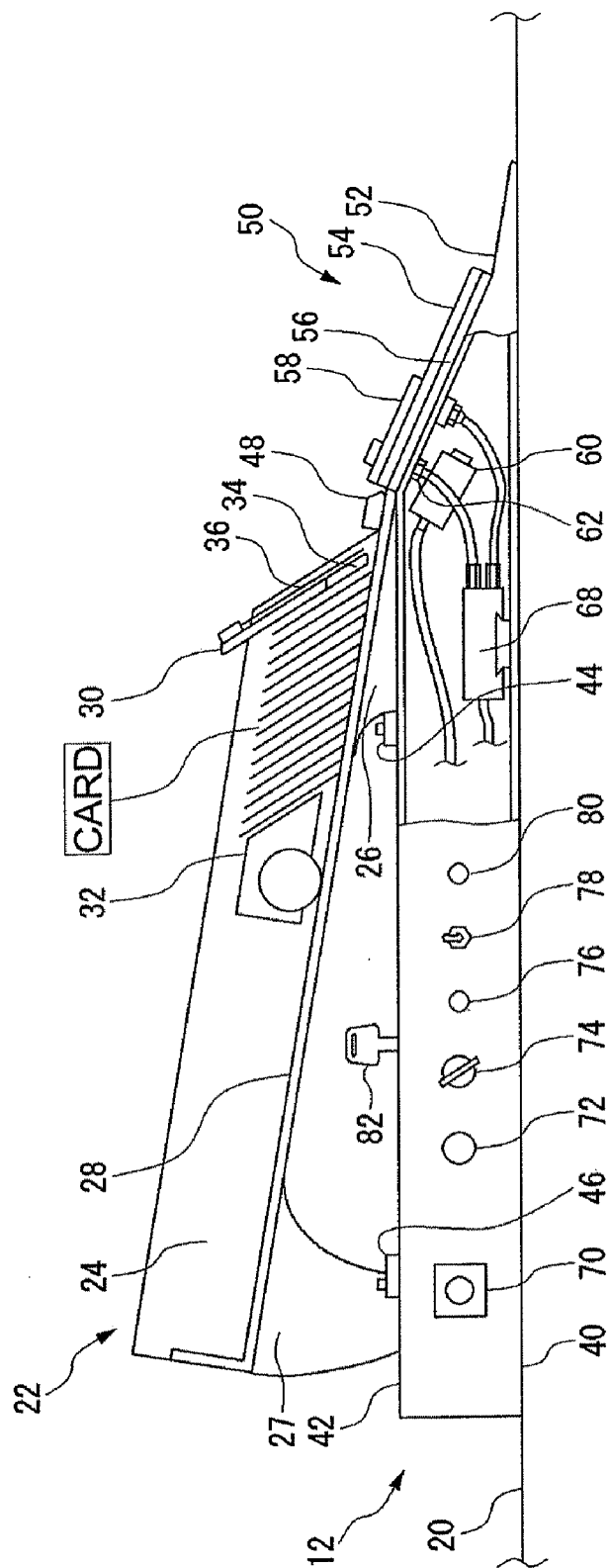

FIG. 3

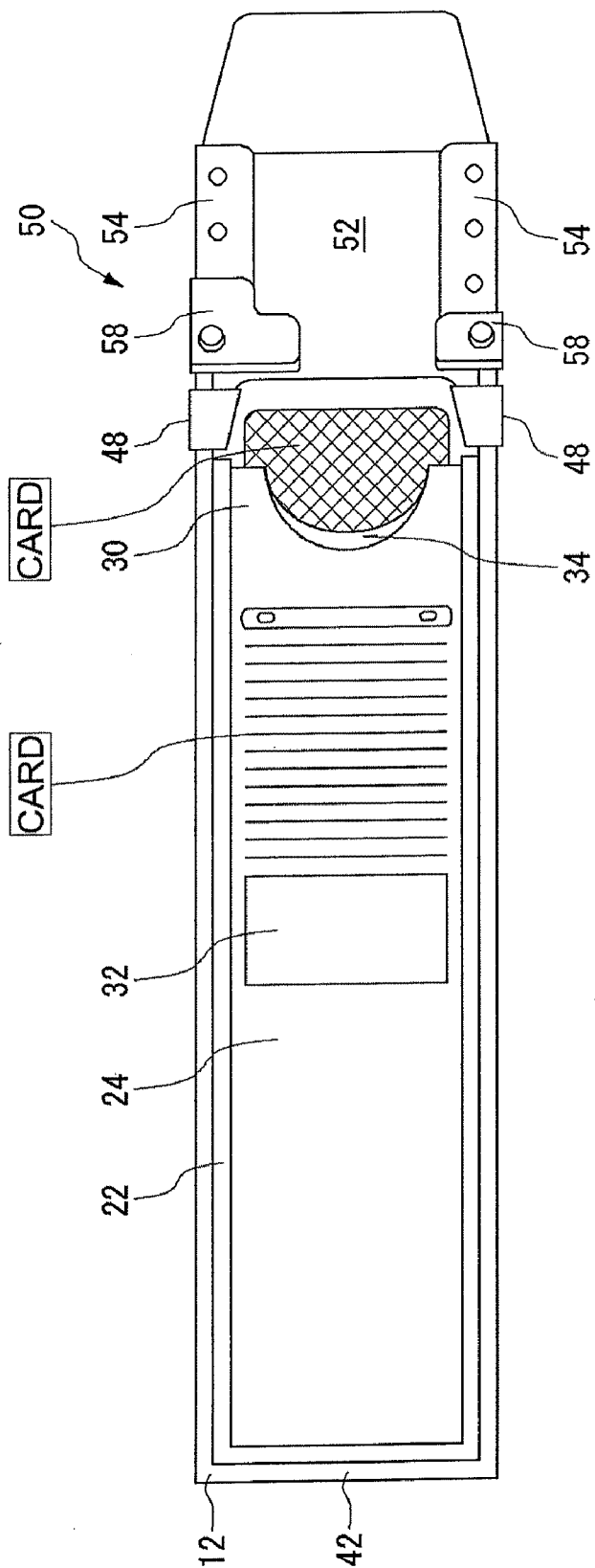

FIG. 4

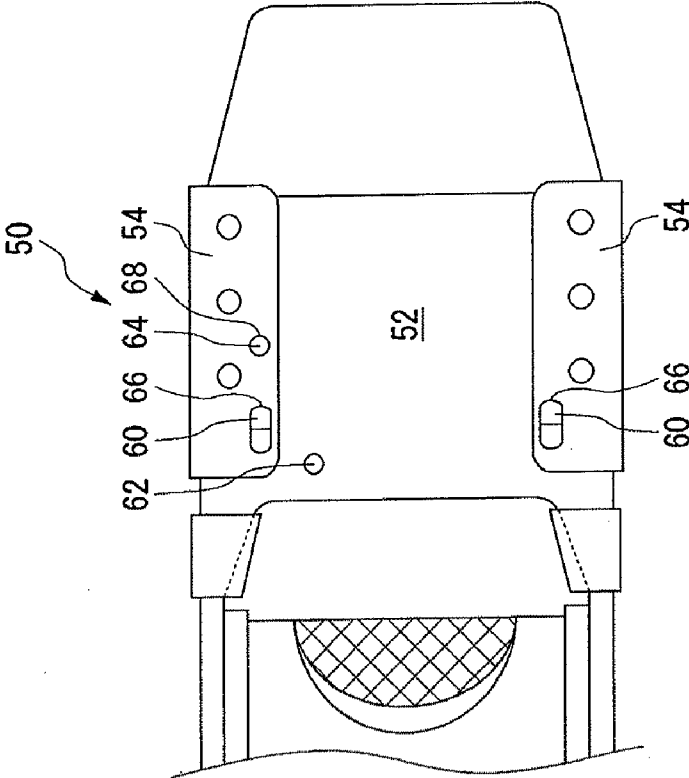

FIG. 5

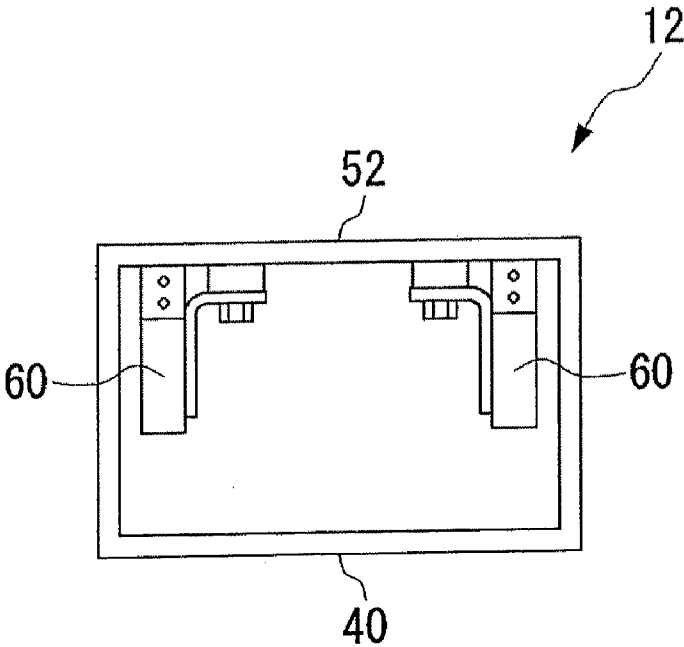

FIG. 6

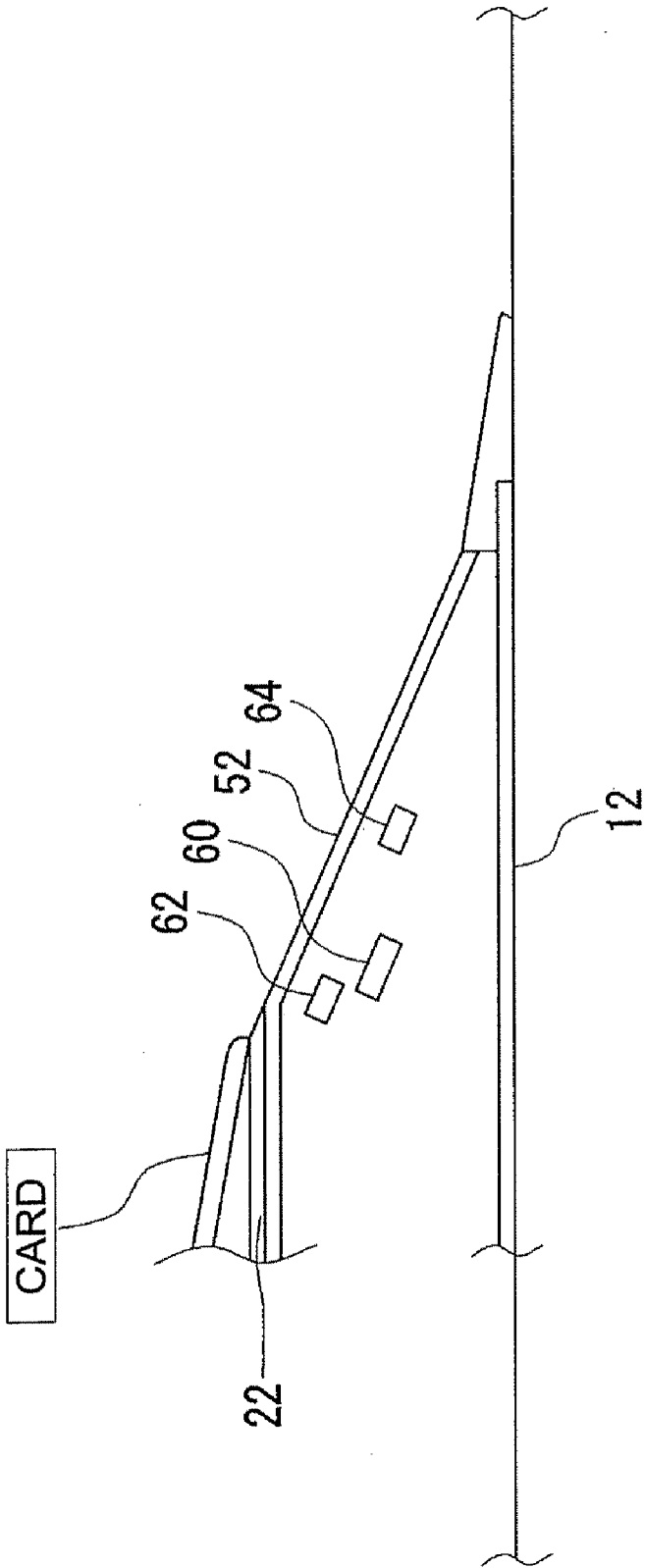

FIG. 7

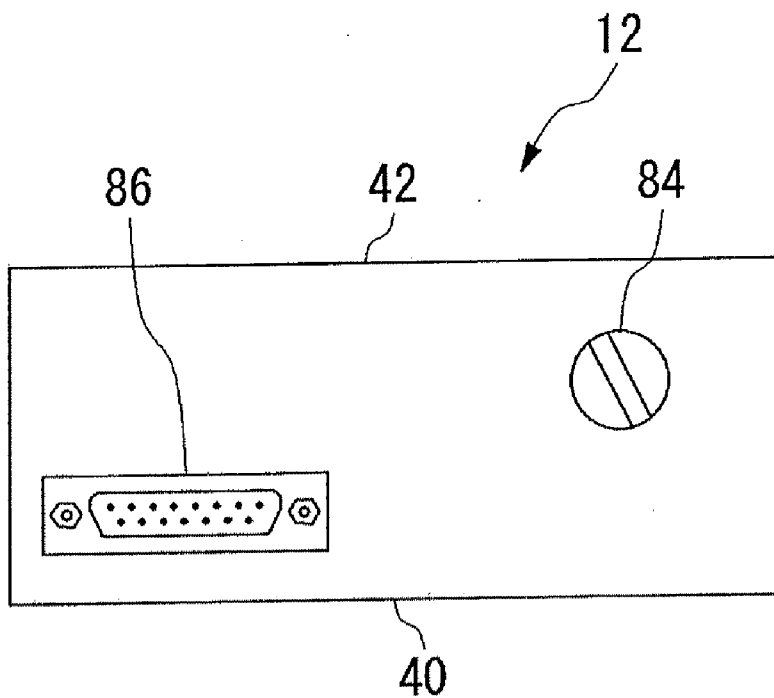

FIG. 8

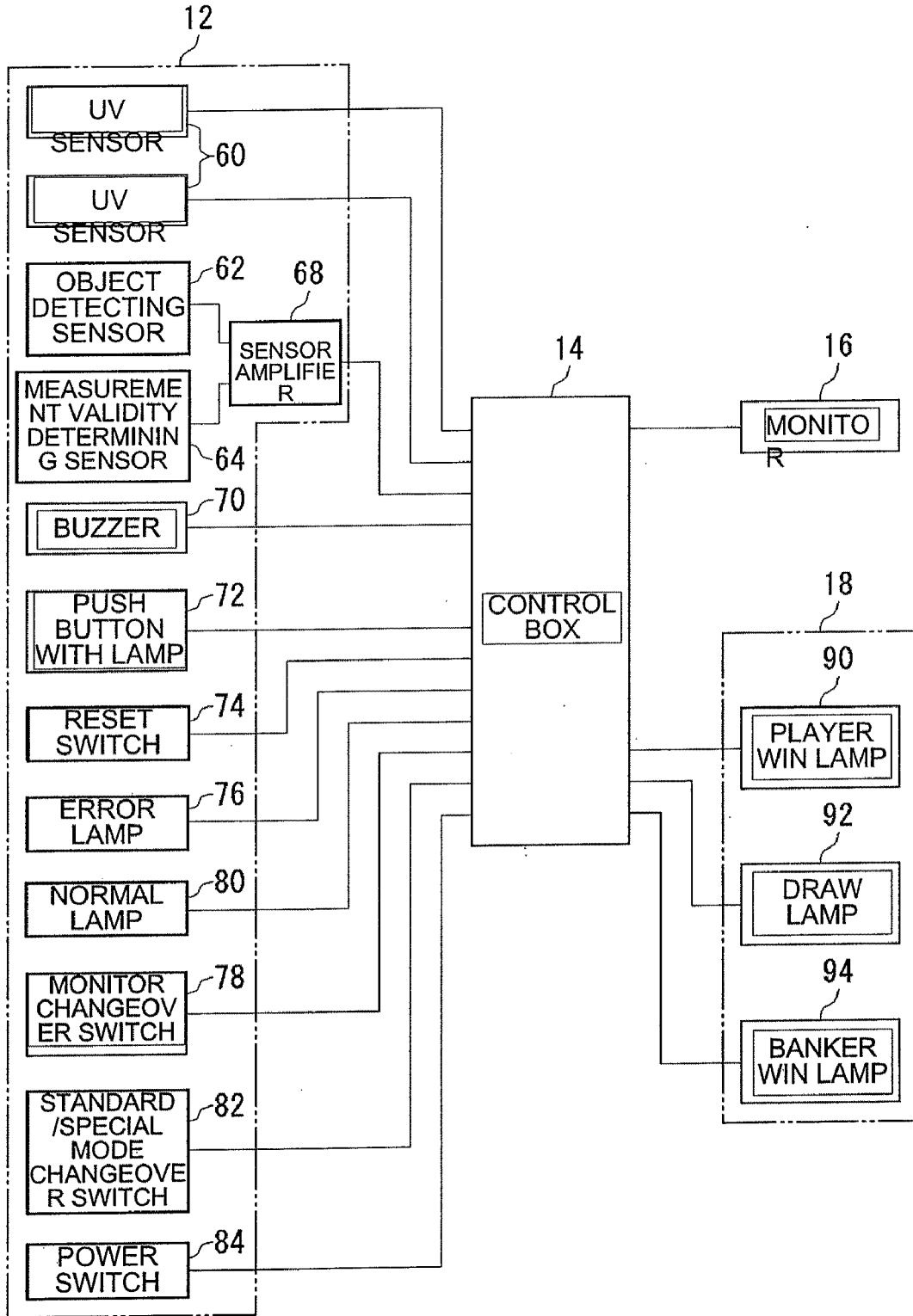

FIG. 9

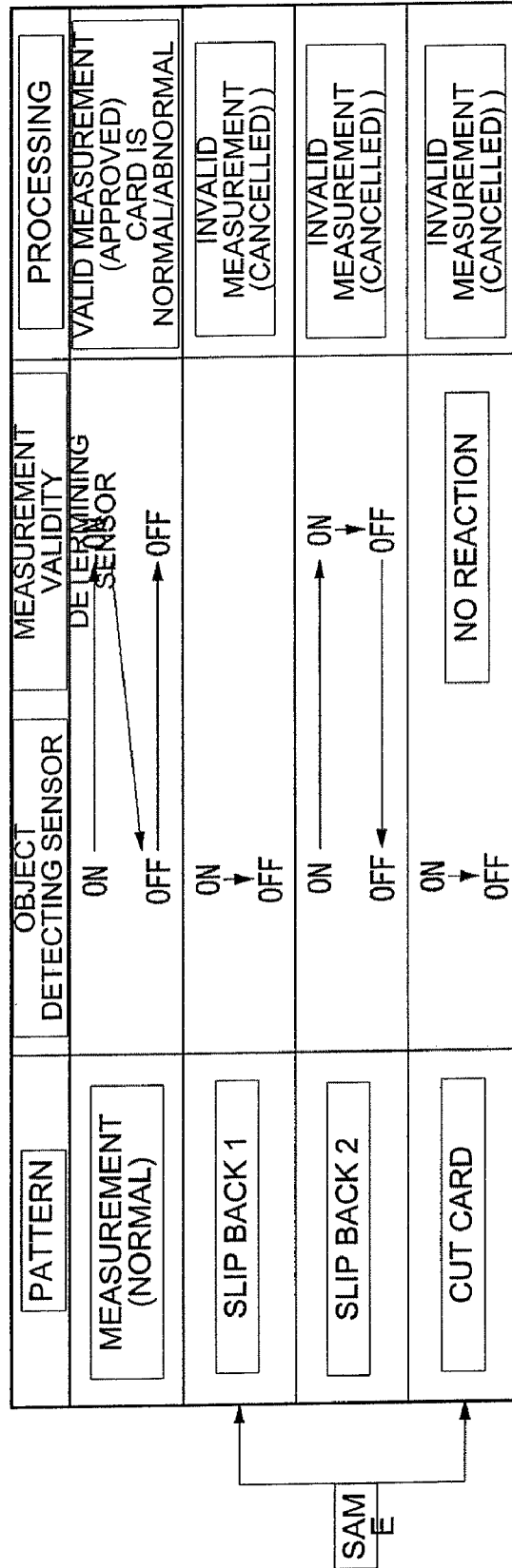

FIG. 10

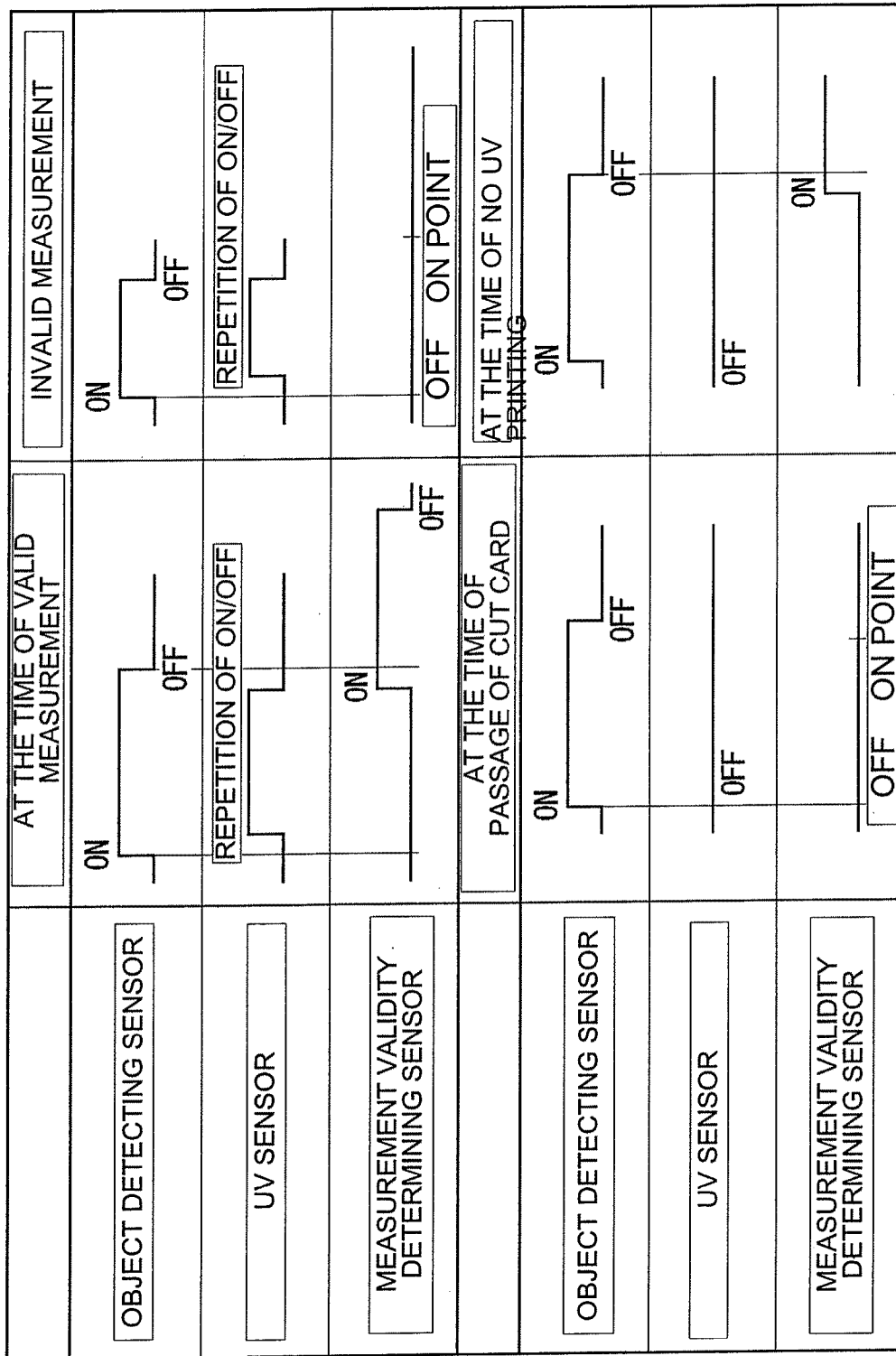

FIG. 11

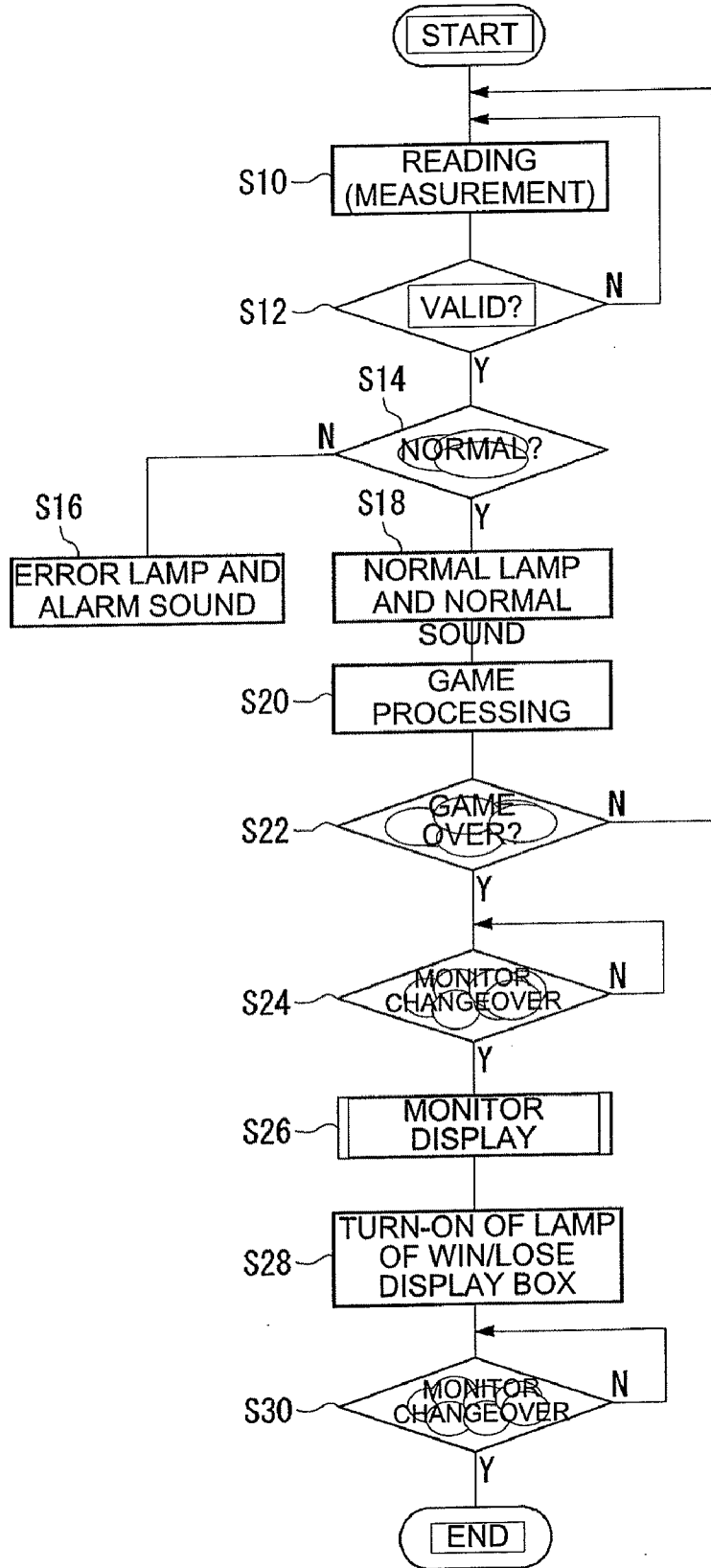

FIG. 12

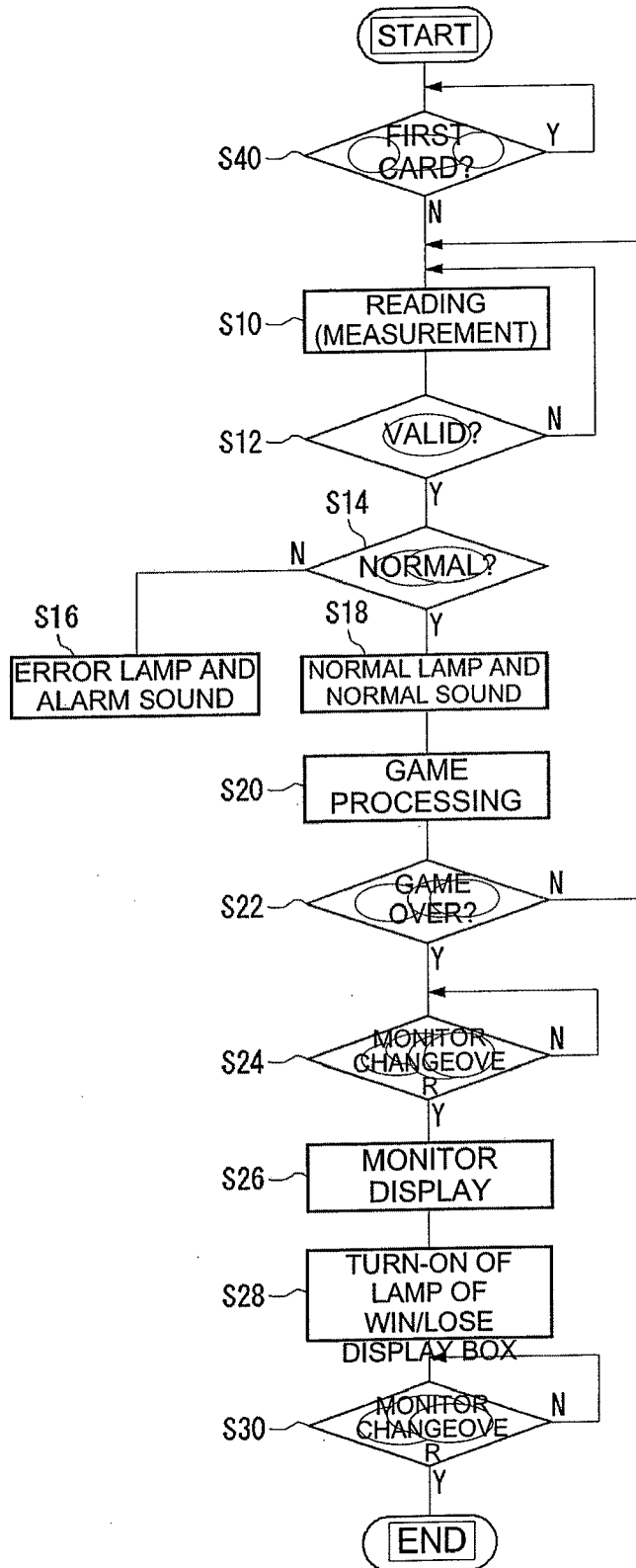

FIG. 13

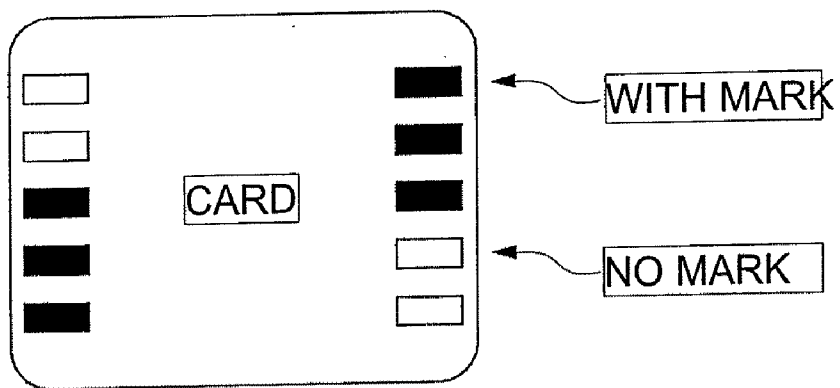
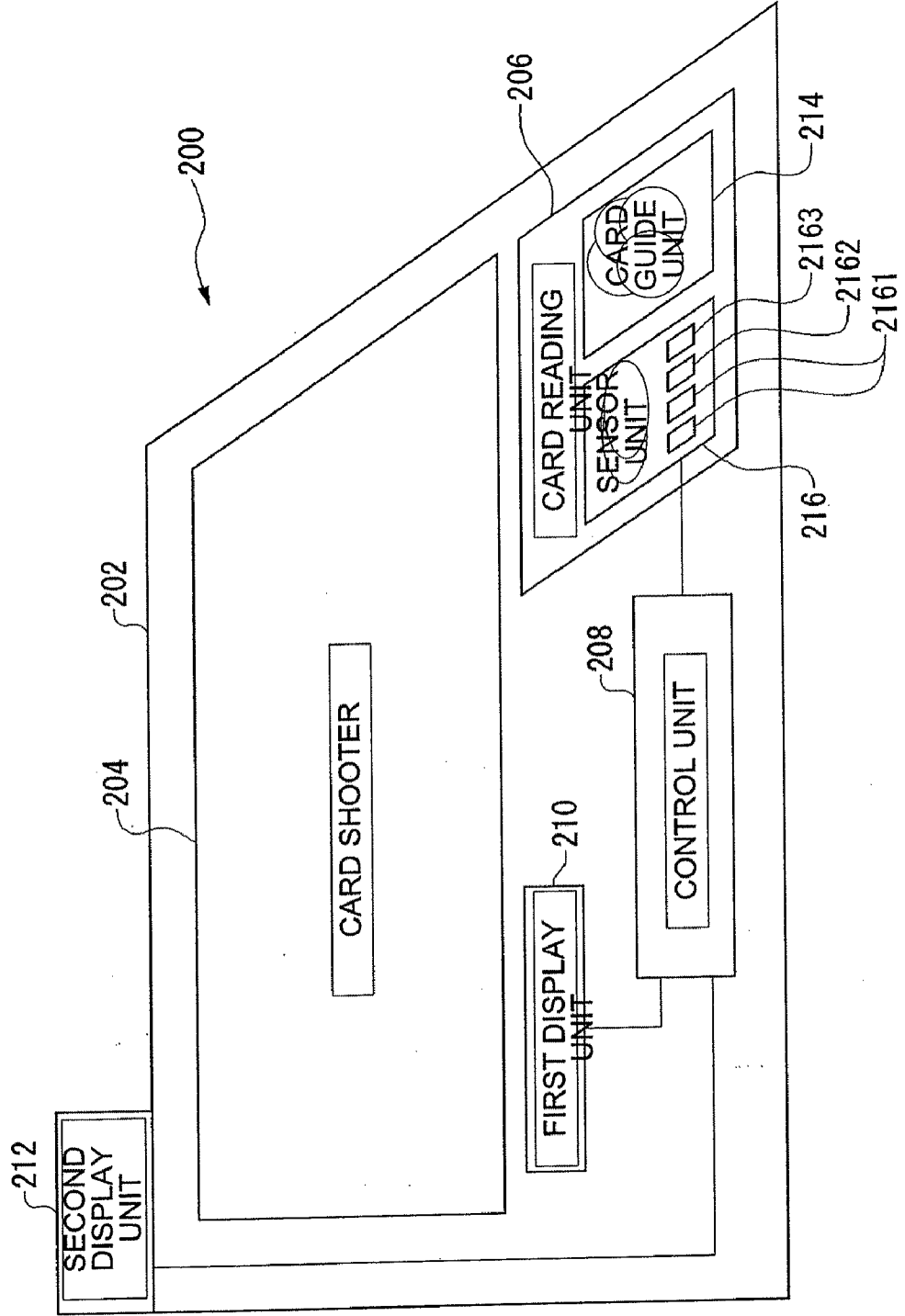

FIG. 14



CARD READING DEVICE

CROSS-REFERENCE TO RELATED APPLICATIONS

[0001] This application is a U.S. National Stage Application under 35 U.S.C. §371 of International Application No. PCT/JP2005/003789, filed Mar. 4, 2005, and claims priority to Japanese Patent Application No. 2004-079519, filed Mar. 19, 2004, all of which are incorporated herein by reference.

FIELD OF THE INVENTION

[0002] The present invention relates to a card reader that reads playing cards (trump cards; hereinafter simply referred to as cards), and particularly, an apparatus that is used suitably for a card game in which a card shooter is to be used.

BACKGROUND OF THE INVENTION

[0003] Conventionally, a card reader that is used suitably for a card game in a casino, etc. is suggested. For example, PCT Japanese Translation Patent Publication No. 10-508236 (Page 12, FIG. 1) discloses a card reader equipped with a card shooter. In the apparatus of this literature, a CCD image sensor and related optical system components are built in the card shooter. Further, an outlet of the card shooter is provided with a card reading window. Also, when a card passes through the shooter outlet, the card is read through the reading window.

[0004] However, in the conventional apparatus, reading precision is restricted by the CCD image sensor and related optical system components. The reading precision is desired to improve as much as possible. This point is also important in reducing the influence on a game progress caused by generation of a read error.

[0005] Further, in the conventional apparatus, in order to secure reading capability, the speed of a card when a card is pulled out of the card shooter needs to be comparatively low, for example, the maximum speed is about 1 m/s. On the other hand, even if the card speed is larger, a card needs to be read accurately. This point is also important in the game progress of a casino, etc.

[0006] The invention has been made in view of the above problems. It is therefore an object of the invention to provide a card reader that is capable of utilizing an existing card shooter, is high in reading precision, and is high in the threshold value of the card speed at the time of reading.

SUMMARY OF THE INVENTION

[0007] One aspect of the present invention is a card reader comprising: a platform; a card shooter mounted on the platform; a card guide unit that guides cards, which are pulled out one by one from the card shooter; and one or more black light sensors provided in the card guide unit to read an ultraviolet-ray reaction code from a card guided by the card guide unit, the ultraviolet-ray reaction code indicating at least the number the card.

[0008] Another aspect of the present invention is a card shooter apparatus having a card reading function, the apparatus comprising: one or more black light sensors that reads an ultraviolet-ray reaction code from cards pulled one by one from a card shooter unit, the ultraviolet-ray reaction code indicating at least the number of each card.

[0009] Another aspect of the present invention is a card reader including: a platform; a card shooter mounted on the platform; a card guide unit that guides cards, which are pulled out one by one from the card shooter; and one or more black light sensors provided in the card guide unit to read an ultraviolet-ray reaction code from a card guided by the card guide unit, the ultraviolet-ray reaction code indicating card information of the card.

[0010] As described hereafter, other aspects of the invention exist. Thus, this summary of the invention is intended to provide a few aspects of the invention and is not intended to limit the scope of the invention described and claimed herein.

BRIEF DESCRIPTION OF THE DRAWINGS

[0011] FIG. 1 is a view showing the overall configuration of a card reader of the present embodiment.

[0012] FIG. 2 is a view showing a platform along with a game table and a card shooter.

[0013] FIG. 3 is a plan view of the platform and the card shooter.

[0014] FIG. 4 is a plan view in a state where a sensor cover is detached.

[0015] FIG. 5 is a sectional view of the platform.

[0016] FIG. 6 is a view showing a sensor arrangement.

[0017] FIG. 7 is a view showing the back surface of the platform.

[0018] FIG. 8 is a block diagram showing a control configuration including a control box.

[0019] FIG. 9 is a view showing sensor output according to situations.

[0020] FIG. 10 is a view showing an example of the output waves of sensors.

[0021] FIG. 11 is a flow chart showing the operation of the card reader when a normal mode is set.

[0022] FIG. 12 is a flow chart showing the operation of the card reader when a special mode is set.

[0023] FIG. 13 is a view showing an example of a card.

[0024] FIG. 14 is a view showing a configuration in which the card reader and the card shooter are integrated.

DETAILED DESCRIPTION OF THE EXEMPLARY EMBODIMENTS

[0025] The following detailed description refers to the accompanying drawings. The following detailed description and the accompanying drawings do not limit the invention. Instead, the scope of the invention is defined by the appended claims.

[0026] A card reader includes: a platform that is set on a game table and has a card shooter mounted thereon; a card guide unit that is provided in the platform to guide cards, which are pulled out one by one from the card shooter, onto the game table; and black light sensors that are provided in the card guide unit to read an ultraviolet-ray reaction code including the number of a card from the card.

[0027] According to this card reader, the platform is provided between the game table and the card shooter, and the platform is provided with a card reading function. Thus, reading of a card is enabled while the existing card shooter is utilized. Moreover, since the black light sensors are used, reading precision is high, and the threshold value of the card speed at the time of reading can also be set to a large value, for example, about 3.6 m/s. Also, the reading result of a card is suitably helpful to prevention of an illegal act.

[0028] Preferably, the card guide unit has a card guide surface, card guide rails are provided at edges of the card guide surface, a card passage gap is formed between the card guide surface and the card guide rails, and the black light sensors are provided so as to read a card from the card guide surface within the card passage gap. Accordingly, the influence of outside light in a card reading part can be reduced, and reading precision can be improved.

[0029] Preferably, the card reader further includes a win/lose determining means that determines the win or lose of a card game on the basis of the numbers of the cards that are sequentially read by the black light sensors, and an output means that outputs a game result determined by the win/lose determining means. Accordingly, the progress of a game can be supported, and an illegal act can be prevented.

[0030] Preferably, the card reader further includes an invalid mode setting means that sets a first card invalid mode that invalidates a card that is first pulled out in each game. Accordingly, even when a rule that invalidates a first card is adopted, the card reader can perform game result determination processing adapted to a card game, and can smoothly process a card game.

[0031] Preferably, the card reader further includes first and second card detecting sensors that are arranged along a guiding direction of the card guide unit to detect the existence or non-existence of a card, and a measurement validity/invalidity determining means that determines whether or not a card has normally passed along the card guide unit, on the basis of detection signals of the first and second card detecting sensors.

[0032] Preferably, the measurement validity/invalidity determining means validates reading of a card when the first card detecting sensor and the second card detecting sensor detect the card in order, and then the first card detecting sensor and the second card detecting sensor stop detecting the card in order.

[0033] Preferably, the measurement validity/invalidity determining means invalidates reading of a card when the first card detecting sensor and the second card detecting sensor detect the card in order, and then the second card detecting sensor and the first card detecting sensor stop detecting the card in order. Accordingly, when a card slips back, it is possible to suitably cope with this.

[0034] Preferably, in the card reader, the sensitivity of the second card detecting sensor is set so as to detect a card for game and so as not to detect a cut card. Accordingly, when a cut card is used, the card reader can suitably cope with this.

[0035] Further, in the card reader, the black light sensors are adapted to detect code elements including a given number from a card which the code elements are arrayed in a card pulling direction as an ultraviolet-ray reaction code, and to

output a detection signal. Also, the card reader includes a number specifying means, and the number specifying means specifies a card associated with the numbers of the code elements on the basis of the detection signals of the black light sensors. The code elements are typically marks printed with ultraviolet-ray reaction ink.

[0036] The numbers of the code elements are associated with at least the number of a card. The numbers of the code elements may be associated with the type (spade, heart, etc.) of a card, in addition to the number of the card. The numbers of the code elements may be associated with other information.

[0037] Further, the ultraviolet-ray reaction code may have plural rows of the code elements. A card may be specified by a combination of the numbers of the plural rows of code elements. In this case, a card is specified from the plural rows of code elements including given numbers. Accordingly, even in this case, the code elements including given numbers are read. Also, the number specifying unit specifies the number of a card associated with the numbers of the code elements.

[0038] Since the black light sensors are provided, the code elements is detected by the black light sensors, and a card is specified from the numbers of the code elements, the card can be detected with high precision.

[0039] A card shooter apparatus has a card reading function to read the number of a card. This card shooter apparatus includes black light sensors that read an ultraviolet-ray reaction code including the number of each of cards that are pulled one by one from a card shooter, from the card. In this aspect, the card shooter and the card reader may be provided separately or integrally. Even in this aspect, an advantage that reading precision can be improved is obtained, and an advantage that the threshold value of the card speed at the time of reading is raised is obtained.

[0040] The card shooter apparatus may further include a housing, a card shooter unit that is provided in the housing, and a card guide unit that is provided in the housing to guide cards pulled out one by one from the card shooter unit onto a game table. Here, the black light sensors are provided in the housing. The black light sensors may be provided in the housing. The housing may include a processing unit that processes the read data of the black light sensors, and a display unit that displays a processing result of the processing unit.

[0041] Hereinafter, embodiments of the invention will be described with reference to the drawings.

[0042] FIG. 1 shows a card reader 10 of the present embodiment. The card reader 10 includes a platform 12, a control box 14 is connected to the platform 12, and a monitor 16, and a win/lose display box 18 are connected to the control box 14. The control box 14 is a computer apparatus that controls the whole apparatus.

[0043] Referring to FIG. 2, the platform 12 is set on a game table 20, and a card shooter 22 (card shoe) is mounted on the platform 12.

[0044] The card shooter 22 may be a general type of existing shooter. The card shooter 22 includes a card housing 24, and a fore leg 26 and a hind leg 27 under the card housing. A floor 28 and a front wall 30 of the card housing 24 incline as shown. Within the card housing 24, a deck of cards is forward

pushed against the front wall **30** by a card push member **32** with a roller. The front wall **30**, as shown in FIG. **3**, has a U-shaped opening **34** in a lower part. A dealer slides the cards to take them out of the opening **34**.

[0045] In addition, black cloth **36** (omitted in the other drawings) is hung on the front wall **30** so as to block the opening **34**. Further, though not shown, a cover is attached to an upper part of the card housing **24**. The card shooter **22** is black as a whole, and is made of resin.

[0046] Next, the configuration of the platform **12** will be described. The platform **12** is black and is made of resin, similarly to the card shooter **22**. The platform **12** has a thin box shape as a whole. The platform **12** has a table mounting surface **40** at the bottom thereof, and a shooter setting surface **42** at the top thereof, and both the surfaces are flat.

[0047] The shooter setting surface **42** is provided with shooter positioning blocks **44** and **46**. The card shooter **22** is put on the shooter setting surface **42** so that the fore leg **26** and the hind leg **27** of the card shooter **22** may contact the shooter positioning blocks **44** and **46**, and thereby, the card shooter **22** is positioned with respect to the platform **12**.

[0048] Further, shooter hold-down blocks **48** are attached to a front end of the shooter setting surface **42**. The shooter hold-down blocks **48** holds down the front end of the card shooter **22** from upside, and thereby, the card shooter **22** is held on the platform **12**.

[0049] The platform **12** has a card guide unit **50** in a front part thereof. The card guide unit **50** guides cards, which are pulled out one by one from the card shooter **22**, onto the game table **20**, as described below.

[0050] As shown in FIGS. **2** and **3**, the card guide unit **50** has a card guide surface **52** that is an inclined plane. One end of the card guide surface **52** is connected with an opening **34** of a card outlet of the platform **12**. The card guide surface **52** extends forward and downward from the front the card outlet, and the other end of the card guide surface is connected with the game table **20**. The card guide surface **52** becomes a measurement surface for card reading.

[0051] Card guide rails **54** are attached to edges on both sides of the card guide surface **52**. As shown in FIG. **2**, a card passage gap **56** is formed between the card guide rails **54** and the card guide surface **52**. The size of the card passage gap **56** is set to be slightly larger than the thickness of a card. After a card is pulled out of the card shooter **22**, it passes along the card guide surface **52**. At this time, both ends of the card pass through the card passage gap **56**.

[0052] Further, the inclination of the card guide surface **50** is changed on the way as shown. The card guide rails **54** are provided in a region before the inclination changes, and the card guide rails **54** is slightly longer than the short sides of a card.

[0053] Further, a sensor cover **58** is attached to each of the two card guide rails **54** with screws. As shown in FIG. **4**, when the sensor covers **58** are detached, four sensors are exposed. The four sensors are two black light sensors **60**, an object detecting sensor **62**, and a measurement validity determining sensor **64**, and these sensors are provided in the card guide surface **52** of the card guide unit **50**. In the drawing, the black light sensors **60** and the measurement validity determining

sensor **64** can be seen from sensor cleaning holes **66** and **67** that pass through the card guide rails **54**.

[0054] As shown in FIG. **4**, the black light sensors **60** (hereinafter referred to as UV sensors **60**) are located on the relatively upstream side in the direction of flow of a card, on the card guide surface **52**. Further, as shown in FIGS. **2** and **5**, the UV sensors **60** are arranged in the inner space of the platform **12**, are fixed to the ceiling (the other side of the card guide surface **52**) of the platform with stays, and are exposed through the opening of the card guide surface **52**.

[0055] Each of the UV sensors **60** includes an LED (ultraviolet LED) that emits ultraviolet rays, and a detector. A card is irradiated with ultraviolet rays (black light), and a code of the card is detected by the detectors. The code of the number (rank: A, 1 to 10, J, Q, and K) of a card is printed on the card with ultraviolet ray emission ink that produces a color when ultraviolet rays strike the card.

[0056] The above UV sensors **60** are connected to the control box **14** through cables. In the control box **14**, the number of a card is determined from output signals of the detectors of the UV sensors **60**.

[0057] Here, as the code the number of a card, for example, a plurality of quadrangular marks are arrayed on edges of the card. The number of the card is expressed by the numbers of the marks. The UV sensors **60** output ON signals when the marks are detected. Accordingly, the UV sensors **60** on both edges output ON signals of the numbers of the marks. In the control box **14**, the ON signals input from the two UV sensors **60** are counted. Thereby, the two mark numbers detected by the two UV sensors **60** are obtained. Also, the control box **14** specifies the number of a card from the numbers of the marks.

[0058] In addition, although the numbers of marks and the number of a card may be the same as each other, they may not be the same as each other. The numbers of the marks and the number of a card only need to match each other one-on-one. In the control box **14**, a detected mark number is compared with a mark number that is registered in advance, and thereby, the number of a card may be specified.

[0059] Further, in the baccarat game, "J", "Q", and "K" are treated as equal to "10." Thus, the same code as "10" may be attached to "J", "Q", and "K." Further, in addition to the number of a card, a code representing a suit (spades, hearts, diamonds, and blacks) may be attached to a card, and this may be read. In this way, the type of codes is not limited if the numbers of cards required for a game are expressed.

[0060] As described above, in the present embodiment, the card reader **10** includes the UV sensors **60** that detects marks from a card and outputs signals. The above UV sensors **60** output ON signals during passage of marks. Marks including a given number are provided on a card, and the marks are provided on the edges of the card, and thereby arrayed in a card pulling direction so that they may pass through the UV sensors **60**. Then, the number of the marks is associated with the number of the card, and the control box **14** specifies the card from detection signals of the UV sensors **60**.

[0061] Further, as described above, in the card reader **10** of the present embodiment, the two UV sensors **60** are provided as shown in FIGS. **4** and **5**. Then, as shown in the example of FIG. **13**, marks are arrayed on both edges of a card in correspondence with both the UV sensors **60**, and the marks are

read by both the UV sensors 60. The marks are suitably provided in a region where a picture is not provided as shown. However, actual marks are not usually visible.

[0062] As described above, in the present embodiment, marks including a given number are suitably arrayed on each edge of a card. As for the association between a mark number and a card, the sum of mark numbers may simply be associated with the number of a card. Further, a combination of two rows of mark numbers may be associated with the number of a card. In the latter form, it is possible to identify more cards by few marks. In addition, FIG. 13 is just illustrative, and the number of mark rows is not limited to two, but the number of rows may be one or three or more. Also, two mark rows are suitably provided on each of both edges of a card. In this case, the arrangement of the UV sensors is also properly adjusted.

[0063] Further, additionally describing the configuration of the control box 14, the control box 14 of the card reader 10 includes a counter, a memory (storage means), and a number specifying unit. The counter counts detection signals from the UV sensors 60, and finds out a mark number. Also, the memory stores information that associates the mark number with a card. The associated information is typically a table. The number specifying unit specifies the number of a card from the numbers of marks with reference to the information of the memory.

[0064] In the present embodiment, the counter is able to find out two mark numbers corresponding to the two UV sensors 60. As described above, in the present embodiment, a combination of a plurality of rows of mark numbers may be associated with a card. In this case, a memory stores information that associates the combination of the mark numbers with a card. Also, the number specifying unit specifies a card corresponding to the combination of the card numbers.

[0065] Next, the object detecting sensor 62 and the measurement validity determining sensor 64 are fiber sensors that detect the existence or non-existence of a card. The object detecting sensor 62 is located on the most upstream side along the flow direction of a card on the card guide surface 52, and the measurement validity determining sensor 64 is located on the downstream side of the object detecting sensor 62. Also, as shown in FIG. 6, the object detecting sensor 62 and the measurement validity determining sensor 64 are provided on the upstream and downstream sides of reading points of the UV sensors 60. The object detecting sensor 62 and the measurement validity determining sensor 64 correspond to a first card detecting sensor and a second card detecting sensor, respectively.

[0066] Further, similarly to the UV sensors 60, the object detecting sensor 62 and the measurement validity determining sensor 64 are arranged in the inner surface of the platform 12, are fixed to the ceiling on the platform, and are exposed through the opening of the card guide surface 52.

[0067] The object detecting sensor 62 and the measurement validity determining sensor 64, as shown in FIG. 2, are connected to the control box 14 by cables via a sensor amplifier 68. The sensor amplifier 68 is of a two channel type, and is able to independently control the object detecting sensor 62 and the measurement validity determining sensor 64. On the basis of detection signals of the object detecting sensor 62 and the measurement validity determining sensor 64, the control box 14, as will be described below, controls the start and end

of reading of the UV sensors 60, and determines whether or not a card has normally passed along the card guide surface 52.

[0068] Further, as shown in FIG. 2, a side surface of the platform 12 is further provided with a buzzer 70, a push button 72 with a lamp, a reset switch 74, an error lamp 76 (red), a monitor changeover switch 78, and a normal lamp 80 (green). In the push button 72 with a lamp, the lamp is turned on or turned off whenever the button is pushed. The reset switch 74 is a switch of a type in which a key inserted into a keyhole is turned, and the monitor changeover switch 78 is a lever switch. Further, the upper surface of the platform 12 is provided with a standard/special mode changeover switch 82. This switch 82 is also a switch of a type in which a key inserted into a keyhole is turned. Further, as shown in FIG. 7, the back surface of the platform 12 is provided with a power switch 84 and a cable connector 86. The above various switches, lamps, buzzer, etc. are connected to the control box 14 through cables, and are used for various kinds of processing of the control box 14.

[0069] The configuration of the platform 12 has been described hitherto. As shown in FIG. 1, the card reader 10 is further provided with the monitor 16 and the win/lose display box 18.

[0070] The monitor 16 is controlled by the control box 14 to display the information on reading of a card, and a game. The win/lose display box 18 is provided with three lamps, i.e., a player-win lamp 90 (red), a draw lamp 92 (yellow), and a banker-win lamp 94 (green). These lamps are controlled by the control box 14, and they are turned on or off in order to display the win or lose of a game. As shown in this description, the card reader 10 of the present embodiment is applied to a baccarat game.

[0071] Further, the monitor 16 and the win/lose display box 18 are set in a proper location on the game table 20. On the other hand, the control box 14 is arranged in a proper location, such as the underside of the game table 20.

[0072] FIG. 8 is a functional block diagram of various components relevant to the control box 14. The control box 14 is a computer apparatus as earlier mentioned. The control box 14 is connected to the UV sensors 60, object detecting sensor 62, and measurement validity determining sensor 64 of the platform 12. Moreover, the control box 14 is connected to the various switches and lamps of the platform 12 to control them. Further, the control box 14 is connected to the monitor 16 and three lamps of the win/lose display box 18 to controls the display of them.

[0073] A computer serving as the control box 14 has a processing function to automatically determine win or lose of a game. This function is realized by incorporating a program for win/lose determination into the computer, and this program is executed by a processor of the computer.

[0074] As determination processing, the computer acquires the numbers of cards, which are sequentially taken out of the card shooter 22 to the game table 20, using the UV sensors 60. The acquired numbers of the cards are sequentially stored in the memory. At this time, the information on to which player each card has been distributed is also stored. That is, the numbers of cards are stored in association with distribution destinations.

[0075] From this point, the card reader 10 of the present embodiment is used in a baccarat game as earlier mentioned. In the baccarat game, two persons including a player and a banker exist (here, both are called players). Also, to which player the next card is to be distributed is uniquely determined from the number of cards distributed by then, and the number of each of the cards. The computer determines to which player a card read by the UV sensors 60 is to be distributed with reference to the numbers of the cards stored in the memory. Also, the number of the distributed card is stored in the memory in association with each player.

[0076] Moreover, the computer reads the numbers of the cards, which have been distributed to both players, from the memory, compares the numbers of the both players, and determines a win or lose. The numbers of the cards are summed, both sums are compared, and which player has won is determined. A draw is also determined.

[0077] As such, concerning the baccarat game, win or lose can be automatically determined only from the numbers of the cards sequentially taken out of the card reader 10. To which player a card has been distributed may not be detected using other sensors, for example, sensors separately embedded in the table.

[0078] The control box 14 causes a game result to be output to the monitor 16 and the win/lose display box 18. Read numbers, a game result, etc. are displayed on the monitor 16. Further, in the win/lose display box 18, a banker-win lamp 90, a draw lamp 92, or a player-win lamp 94 are turned on according to the game result.

[0079] Next, the functions of the object detecting sensor 62 and measurement validity determining sensor 64 will be described. As already described, the object detecting sensor 62 and the measurement validity determining sensor 64 detect the existence or non-existence of a card, and output detection signals to the control box 14. In the present embodiment, if a card exists, a signal is turned on, and if a card disappears, a signal is turned off.

[0080] First, the detection signal of the object detecting sensor 62 is used to control the start and end of reading of the UV sensors 60. That is, when the object detecting sensor 62 detects a card (from OFF to ON), the control box 14 instructs the UV sensors 60 to start reading. In the UV sensors 60, an LED is turned on, and a detector reads code. When the object detecting sensor 62 stops detecting a card (from ON to OFF), the control box 14 instructs the UV sensors 60 to end reading. In the UV sensors 60, an LED is turned off.

[0081] The object detecting sensor 62 and the measurement validity determining sensor 64 are further used to determine whether or not a card has normally passed along the card guide surface 52.

[0082] The first step of FIG. 9 shows a sensor output when (when a card has normally passed along the card guide surface) measurement is normal. In this case, a signal is turned on in order of the object detecting sensor 62 and the measurement validity determining sensor 64, and then, the signal is turned off in order of the object detecting sensor 62 and the measurement validity determining sensor 64. The reading result (measurement result) of the UV sensors 60 is valid (reading is approved).

[0083] However, if passage of a card is normal, but a mark number read by the UV sensors 60 read is abnormal, the

control box 14 determines that the card itself is abnormal. For example, a card is abnormal when there is no mark at both edges of the card. The numbers of marks may be registered, and be compared with a detected mark number.

[0084] The second step of FIG. 9 shows a sensor output when a card slightly comes out onto a card guide, and slips back. The object detecting sensor 62 is turned on, and then, the object detecting sensor 62 is turned off. Since a card has not reached the measurement validity determining sensor 64, the measurement validity determining sensor 64 is not turned on. In this case, the reading result of the UV sensors 60 is invalidated.

[0085] The third step of FIG. 9 shows a sensor output when a card slips back after the card has reached the measurement validity determining sensor 64. A signal is turned on in order of the object detecting sensor 62 and the measurement validity determining sensor 64, and then, the signal is turned off in order of the measurement validity determining sensor 64 and the object detecting sensor 62. Even in this case, the reading result of the UV sensors 60 is invalidated.

[0086] The fourth step of FIG. 9 shows a sensor output when a cut card is taken out. Here, the cut card is a card used in a casino, etc., and is inserted into a deck of cards. Cards following the cut card are not used for a game. If this cut card is not disregarded, a read error is generated. Then, in order to disregard the cut card, the present embodiment is configured as follows.

[0087] Blue is given to the cut card. The sensitivity of the object detecting sensor 62 is adjusted so as to detect white and a mark color (a color when ultraviolet-ray reaction ink produces a color) as well as a blue object. On the other hand, the sensitivity of the object detecting sensor 64 is adjusted so as not to detect a blue object but to detect a white object and an object with a mark color. This is realized by lowering the sensitivity of the measurement validity determining sensor 64.

[0088] Since such sensitivity setting has been performed, when a cut card passes by as shown in the fourth step of FIG. 9, the object detecting sensor 62 is turned on, and then turned off. The measurement validity determining sensor 64 does not react. Accordingly, the same sensor output as the second step of FIG. 9 is obtained, and accordingly, reading of the UV sensors 60 is invalidated. In this way, passage of a cut card can be suitably disregarded.

[0089] In addition, although a cut card is blue in the above example, the invention is not limited thereto. A separate color may be given as long as it can adjust sensor sensitivity so that only a cut card may not be detected.

[0090] FIG. 10 shows examples of the above-mentioned sensor output waves. When measurement is valid, the object detecting sensor 62 and the measurement validity determining sensor 64 are normally turned on and off as described above. Also, the UV sensors 60 are turned on and off during the measurement (during "ON" of the object detecting sensor 62), and the number of a card is found out from ON/OFF signals of the UV sensors 60.

[0091] Since the card slips back in the following pattern, the object detecting sensor 62 is turned off before the measurement validity determining sensor 64 is turned on. Therefore, the reading result of the UV sensors 60 during the measurement is invalidated.

[0092] Since the cut card has passed along the card guide surface in the following pattern, only the object detecting sensor 62 is turned on and off, similarly to the above pattern. The UV sensors 60 do not output any ON signal. Even in this case, the reading result is invalidated.

[0093] Since a card on which a code is not printed has passed along the card guide surface in the following pattern, the object detecting sensor 62 and the measurement validity determining sensor 64 are normally turned on and off, but the UV sensors 60 are kept turned off during the measurement. In this case, the control box 14 determines that an abnormal card has passed along the card guide surface.

[0094] The functions of sensors have been described hitherto in detail. Next, the operation of the card reader 10 of the present embodiment will be described.

[0095] FIG. 11 shows the operation of the card reader 10 when one game is performed. The power switch 84 is turned on as a precondition of the operation of FIG. 11. Further, the lever of the monitor changeover switch 78 is tilted to a position “before a game,” and the “before a game” is displayed on the monitor 16. Moreover, the key of the reset switch 74 is turned to the left that is a normal position. Further, the standard/special mode setting switch 82 is turned to the standard side.

[0096] A first card is read in this state (S10). It is determined whether or not reading (measurement) has been valid (S12) on the basis of the output of the object detecting sensor 62 and the measurement validity determining sensor 64. If the answer is NO (invalid) in S12, the process returns to S10. For example, when a card has slipped back or a cut card has passed along the card guide surface, the process returns to S10 from S12.

[0097] If the answer is YES (valid) in S12, it is determined whether or not the code of the card is normal (S14). For example, if there is no code, the answer is set to NO in S14. In this case, the error lamp 76 is turned on, and an alarm sound is emitted from the buzzer 70 (S16). An alarm sound is, for example, a large volume of continuous sound. If a reset switch 74 is operated, the alarm sound will stop. The reset switch 74 is turned to the right from the left, and slips back to the left.

[0098] If the answer is YES (normal) in S14, the normal lamp 80 is turned on, and a sound indicating normality from the buzzer 70 is emitted (S18). For example, a short small sound is output.

[0099] Next, game processing is performed (S20). Here, as earlier mentioned, the read number of the card is stored for a player or a banker. Then, the number of the card that is stored in advance is compared, it is determined whether or not the game is ended, and the win or lose of the game is determined. If the game is not ended (S22, NO), the process returns to S10 where the next card is read. If the game is ended (S22, YES), the process will wait for the operation of the monitor changeover switch 78 (S24).

[0100] Also, if the lever of the monitor changeover switch 78 is tilted to a position “after a game” (S24, YES), the display of the monitor 16 is switched to “after a game,” and a win or lose is displayed (S26). Further, even in the win/lose display box 18, a lamp corresponding to a game result is turned on (S28).

[0101] If the lever of the monitor changeover switch 78 is tilted to a position “before a game” (S30, YES), the display of the monitor 16 is changed to “before a game,” and the processing is completed. Then, the process proceeds to the next game, and the processing of FIG. 11 is performed again.

[0102] FIG. 12 shows the operation of the card reader 10 when a special mode is set. The special mode is set by the control box 14 when the standard/special mode changeover switch 82 is turned to “Special.” The special mode is a first card invalid mode in which a card that is first pulled out in each game is invalidated.

[0103] FIG. 12 is different from FIG. 11 in that it is first determined whether or not any card is first just before S10 (S40). Here, for example, the object detecting sensor 62 and the measurement validity determining sensor 64 are turned on in this order, and turned off in this order. As a result, when a card has passed along the card guide surface, it is determined whether or not this card is first. If a card is first, the process does not proceed to S10 but returns to S40. If a card is not first, the process proceeds to S10. Accordingly, the second and succeeding cards are read.

[0104] Whether or not a card is first is determined, for example, using a flag. That is, when the flag is not raised in the processing of S40, it is determined that the card is first, and the flag is raised. Also, if the flag is raised, it will be determined that the card is not first. The flag is reset after the game is ended.

[0105] In addition, in the push button 72 with a lamp in the platform 12, a lamp is turned on or turned off whenever the button is pushed. When the button 72 is turned off, the card reader 10 reads a card as described above. On the other hand, when the button 72 is turned on, the card reader 10 does not read a card. The button 72 is used, for example, when reading of the card reader 10 is temporarily suppressed.

[0106] The preferred embodiment has been described hitherto. According to the present embodiment, the platform 12 is provided between the game table 20 and the card shooter 22, and the platform 12 is provided with a card reading function. Thus, reading of a card is enabled while the existing card shooter 22 is utilized. Moreover, since the black light sensors 60 are used, reading precision is high, and the threshold value of the card speed at the time of reading can also be set to a large value, for example, about 3.6 m/s. In this way, a card reader that is capable of utilizing an existing card shooter, is high in reading precision, and is high in the threshold value of the card speed at the time of reading can be provided. Also, the reading result of a card is suitably helpful to prevention of an illegal act.

[0107] Further, in the present embodiment, the card guide 50 has the card guide surface 52, the edge of the card guide surface 52 is provided with the card guide rails 54, and the card passage gap 56 is formed between the card guide surface 52 and the card guide rails 54. Also, the black light sensors 60 are provided so as to read a card from the card guide surface 52 within the card passage gap 56. Accordingly, the influence of outside light in a card reading part can be reduced, and reading precision can be improved.

[0108] Further, in the present embodiment, the computer of the control box 14 functions as a win/lose determining means, the win or lose of a card game is automatically determined on the basis of the numbers of cards that are sequentially read by

the black light sensors, and the determined game result is output from the monitor **16** and the win/lose display box **18**. Thus, an illegal act can be prevented while the progress of a game can be supported.

[0109] Further, in the present embodiment, the computer of the control box **14** functions as an invalid mode setting means, and a first card invalid mode can be set as described above. Accordingly, even when a rule that invalidates the first card is adopted, the card reader **10** can perform game result determination processing adapted to a card game, and can progress a card game smoothly.

[0110] Further, in the present embodiment, first and second card detecting sensors (the object detecting sensor **62** and the measurement validity determining sensor **64**) are arranged along the guiding direction of the card guide unit **50**, and the computer of the control box **14** functions as a measurement validity/invalidity determining means. Accordingly, the computer of the control box **14** can determine whether or not a card has normally passed along the card guide unit **50**.

[0111] Further, in the present embodiment, the computer of the control box **14** suitably determines that a card normally passed along the card guide unit, when the first card detecting sensor and the second card detecting sensor detect the card in order, and then, the first card detecting sensor and the second card detecting sensor stop detecting a card in order.

[0112] Further, in the present embodiment, the computer of the control box **14** invalidates reading of a card, when the card is detected in order of the first card detecting sensor and the second card detecting sensor, and then, detecting a card is stopped in order of the first card detecting sensor and the second card detecting sensor. Accordingly, when a card slips back, it is possible to suitably cope with this.

[0113] Further, in the present embodiment, the sensitivity of a second card detecting sensor is set low so as to detect a card for a game and so as not to detect a cut card. Accordingly, when a cut card is used, it is possible to suitably cope with this.

[0114] Further, in the card reader **10** of the above-described present embodiment, the black light sensors (UV sensors) detect code elements including a given number from a card which the code elements are arrayed in a card pulling direction as an ultraviolet-ray reaction code, and outputs a detection signal. Also, the card reader **10** includes a number specifying means, and the number specifying means specifies a card associated with the numbers of the code elements on the basis of the detection signals of the black light sensors. In the above embodiment, the code elements are marks printed with ultraviolet-ray reaction ink. Further, the number specifying means is the computer of the control box.

[0115] Further, an ultraviolet-ray reaction code may have plural rows of the code elements like the above example. A card may be specified by a combination of the numbers of the plural rows of code elements. In this case, a card is specified from the plural rows of code elements including given numbers. Accordingly, even in this case, the code elements including given numbers are read. Also, the number specifying unit specifies the number of a card associated with the numbers of the code elements.

[0116] In the present embodiment, as described above, the numbers of the code elements are associated with at least the

number of a card. The numbers of the code elements may be associated with the type (spade, heart, etc.) of a card, in addition to the number of the card. Moreover, the numbers of the code elements may be associated with other information.

[0117] According to the present embodiment, since the black light sensors are provided, the code elements are detected by the black light sensors, and a card is specified from the numbers of the code elements, the card can be detected with high precision.

[0118] Here, the advantages of the present embodiment will be described in more detail by contrast with a conventional technique.

[0119] The conventional technique uses a visible light camera. When the visible light camera is used, an existing conventional picture must be used for a card. The code elements like the present embodiment cannot be used for the following reason. That is, since only a photographic subject of visible light can be read when a camera is used, the code elements should also be printed with visible light ink. However, adding code elements onto a card separately from the conventional existing picture is not allowed in appearance. Accordingly, when the visible light camera is used, the code elements like the present embodiment cannot be used. On the other hand, the black light sensors are used in the present embodiment. Accordingly, the code elements just need to react to ultraviolet rays. That is, the code elements may not ordinarily be a photographic subject of visible light. As such, in the present embodiment, the black light sensors are provided so that the code elements can be utilized as objects to be read other than a conventional picture of a card.

[0120] Further, since the visible light camera is conventionally used, the conventional card picture must be used as described above. Therefore, the precision of reading is low, and the threshold value of the card speed at the time of reading is also low. On the other hand, in the present embodiment, the black light sensors detect code elements. Also, a card is specified from the numbers of the code elements. The code elements are, for example, marks. The numbers of the marks just needs to be counted, not the image processing of a picture. Such counting can be performed with high precision. Also, even if the card speed is increased, the counting of the mark numbers can be performed with high precision.

[0121] Further, the present embodiment is also different from a bar code reader. In the bar code reader, the thickness of a line is an object to be read. On the other hand, in the present embodiment, the thickness of a line is not detected, but marks are simply detected, and a card is specified from the numbers of the marks. Accordingly, even if the present embodiment is compared with the bar code reader, reading is precise, and the threshold value of the card speed at the time of reading increases.

[0122] As such, in the present embodiment, (1) black light sensors are provided, whereby objects to be read become code elements other than the conventional picture, and (2) unlike the conventional image processing of a picture, code elements are detected, and a card is specified from the numbers of the code elements. By virtue of these factors, precision of reading can be improved compared with the conventional technique, and the threshold value of the card speed at the time of reading can also be made high.

[0123] As an additional advantage, according to the present embodiment, code elements are suitably given to all the cards.

Accordingly, it can be understood that, when any code elements are not detected, a card is abnormal. This is suitably helpful to prevention of an illegal act.

[0124] Further, as an additional advantage, according to the present embodiment, the black light sensors can be used to miniaturize an apparatus compared with a configuration provided with the conventional visible light camera.

[0125] Further, in the card reader 10 of the present embodiment, the platform 12, the control box 14, the monitor 16, and the win/lose display box 18 are separately provided. As a modified example, some or all of them may be integrated. For example, the control box 14 may be built in the platform 12.

[0126] Further, since the card reader 10 of the present embodiment can be used for checking of a card for illegal act prevention, etc., it can be called a card checking apparatus. Also, since the card reader is used along with a shoe (shooter), it can also be called a shoe-type checking apparatus. Also, reading of a code in the above embodiment can also be called measurement for checking. Accordingly, the UV sensors 60 may be called code reading sensors, and may be called measuring sensors.

[0127] In another modified example, the card reader 10 of the present embodiment is integrated with a card shooter. In this case, an advantage that an existing card shooter can be utilized is no longer obtained. However, an advantage that reading precision can be improved is obtained, and an advantage that the threshold value of the card speed at the time of reading is raised is obtained.

[0128] FIG. 14 shows an integrated configuration. A card shooter apparatus 200 includes a housing 202. The housing 202 corresponds to the configuration in which the housing of the shooter and the housing of the platform in the above-described embodiment are integrated together. The housing 202 is provided with a card shooter unit 204. The card shooter unit 204 includes various components of the above-described card shooter.

[0129] The housing 202 is further provided with a card reading unit 206, a control unit 208, a first display unit 210, and a second display unit 212. The card reading unit 206 is composed of a card guide unit 214 and a sensor unit 216.

[0130] The card guide unit 214 has the same function as the card guide unit in the above-described embodiment. In the above-described embodiment, the card guide unit is provided in the platform. In this configuration, the card guide unit 214 is provided in the housing 202. The card guide unit 214 may be connected with a card outlet of the card shooter unit 204, and may be integrated with the outlet.

[0131] The sensor unit 216 is composed of the sensors of the above-described embodiment. That is, the sensor unit 216 has a black light sensor 2161, an object detecting sensor 2161, a measurement validity determining sensor 2163, and related components. In the above-described embodiment, the sensors are built in the platform. In this configuration, the sensor unit 216 is built in the housing 202. Also, the sensor unit 216 is located in the place where the card guide unit 206 exists.

[0132] The control unit 208 is a control device corresponding to the control box of the above-described embodiment. In the above-described embodiment, the control box is arranged separately from the platform. In this configuration, the control unit 208 is built in the housing 202.

[0133] The first display unit 210 is the monitor of the above-described embodiment. The second display unit 212 corresponds to the three lamps of the win/lose display box in the above-described embodiment. In the above-described embodiment, the monitor and the lamps are disposed on the table apart from the platform. In this configuration, the monitor of the first display unit 210 is provided on a side surface of the housing 202. Further, the second display unit 212 is provided at a rear end of an upper surface of the housing 202.

[0134] Similarly to the above-described embodiment, in the card shooter apparatus 200, a card is read, read data is processed, and a processing result is displayed.

[0135] The preferred embodiment of the invention has been described hitherto. However, it is natural that the invention is not limited to the above-described embodiment, but persons skilled in the art can alter the above-described embodiment within the scope of the invention.

INDUSTRIAL APPLICABILITY

[0136] The invention can improve the reading precision of the code of a card, and is useful in prevention of an illegal act.

What is claimed is:

1. A card reader comprising:

a platform;

a card shooter mounted on the platform;

a card guide unit that guides cards, which are pulled out one by one from the card shooter; and

one or more black light sensors provided in the card guide unit to read an ultraviolet-ray reaction code from a card guided by the card guide unit, the ultraviolet-ray reaction code indicating at least the number the card.

2. The card reader according to claim 1, wherein the card guide unit includes a card guide surface, card guide rails provided at edges of the card guide surface, and a card passage gap formed between the card guide surface and the card guide rails.

3. The card reader according to claim 2, wherein the black light sensor is provided so as to read a card from the card guide surface within the card passage gap.

4. The card reader according to claim 1, further comprising:

a win/lose determining means that determines the result of a card game on the basis of the numbers of the cards that are sequentially read by the black light sensors; and

an output means that outputs the result determined by the win/lose determining means.

5. The card reader according to claim 4, further comprising:

an invalid mode setting means that sets a first card invalid mode in which the reading of the first card that is pulled out of the card shooter apparatus in each game is invalidated.

6. The card reader according to claim 1, further comprising:

first and second card detecting sensors that are arranged along a guiding direction of the card guide unit to detect the existence or non-existence of a card; and

a measurement validity/invalidity determining means that determines whether or not a card has normally passed along the card guide unit on the basis of detection signals from the first and second card detecting sensors.

7. The card reader according to claim 6, wherein the measurement validity/invalidity determining means validates the reading of a card when the first card detecting sensor and the second card detecting sensor detect the card in sequence, and then the first card detecting sensor and the second card detecting sensor stop detecting the card in sequence.

8. The card reader according to claim 6, wherein the measurement validity/invalidity determining means invalidates the reading of a card when the first card detecting sensor and the second card detecting sensor detect the card in sequence, and then the second card detecting sensor and the first card detecting sensor stop detecting the card in sequence.

9. The card reader according to claim 6, wherein the sensitivity of the second card detecting sensor is set so as to detect a card for a game and so as not to detect a cut card which is not used for the game.

10. The card reader according to claim 1, wherein the black light sensor is adapted to detect code elements from a card on which the code elements are arrayed as an ultraviolet-ray reaction code.

11. The card reader according to claim 10, wherein the code elements are marks printed with ultraviolet-ray reaction ink.

12. The card reader according to claim 10, wherein the code elements are arrayed in a card pulling direction.

13. The card reader according to claim 1, further comprising:

a number specifying means that specifies the number of a card associated with the ultraviolet-ray reaction code on the basis of detection signals of the black light sensor.

14. A card shooter apparatus having a card reading function, the apparatus comprising:

one or more black light sensors that reads an ultraviolet-ray reaction code from cards pulled one by one from a card shooter unit, the ultraviolet-ray reaction code indicating at least the number of each card.

15. The card shooter apparatus according to claim 14, further comprising:

a housing;

a card shooter unit provided in the housing; and

a card guide unit provided in the housing to guide cards pulled out one by one from the card shooter unit,

wherein the black light sensor is provided in the housing.

16. A card reader comprising:

a platform;

a card shooter mounted on the platform;

a card guide unit that guides cards, which are pulled out one by one from the card shooter; and

one or more black light sensors provided in the card guide unit to read an ultraviolet-ray reaction code from a card guided by the card guide unit, the ultraviolet-ray reaction code indicating card information of the card.

* * * * *