



(51) International Patent Classification:

A61M 1/16 (2006.01) B01D 63/02 (2006.01)
A61M 1/26 (2006.01)

(21) International Application Number:

PCT/IB2015/053493

(22) International Filing Date:

12 May 2015 (12.05.2015)

(25) Filing Language:

English

(26) Publication Language:

English

(71) Applicant: **SORIN GROUP ITALIA S.R.L.** [IT/IT]; Via Statale 12 Nord, 86, I-41037 Mirandola (Modena) (IT).

(72) Inventors: **MAZZOLI, Adriano**; Via Baraldini, 106/A, I-41038 San Felice S.P. (Modena) (IT). **REGGIANI, Stefano**; Via Provinciale, 36, I-41936 Medolla (Modena) (IT).

(74) Agent: **DE BONIS, Paolo**; Buzzi, Notaro & Antonielli d'Oulx S.r.l., Via Maria Vittoria, 18, I-10123 Torino (IT).

(84) Designated States (unless otherwise indicated, for every kind of regional protection available):

ARIPO (BW, GH, GM, KE, LR, LS, MW, MZ, NA, RW, SD, SL, ST, SZ, TZ, UG, ZM, ZW), Eurasian (AM, AZ, BY, KG, KZ, RU, TJ, TM), European (AL, AT, BE, BG, CH, CY, CZ, DE, DK, EE, ES, FI, FR, GB, GR, HR, HU, IE, IS, IT, LT, LU, LV, MC, MK, MT, NL, NO, PL, PT, RO, RS, SE, SI, SK, SM, TR), OAPI (BF, BJ, CF, CG, CI, CM, GA, GN, GQ, GW, KM, ML, MR, NE, SN, TD, TG).

Published:

— with international search report (Art. 21(3))

(81) Designated States (unless otherwise indicated, for every kind of national protection available): AE, AG, AL, AM,

(54) Title: BLOOD GAS EXCHANGER WITH RESTRICTION ELEMENT OR ELEMENTS TO REDUCE GAS EXCHANGE

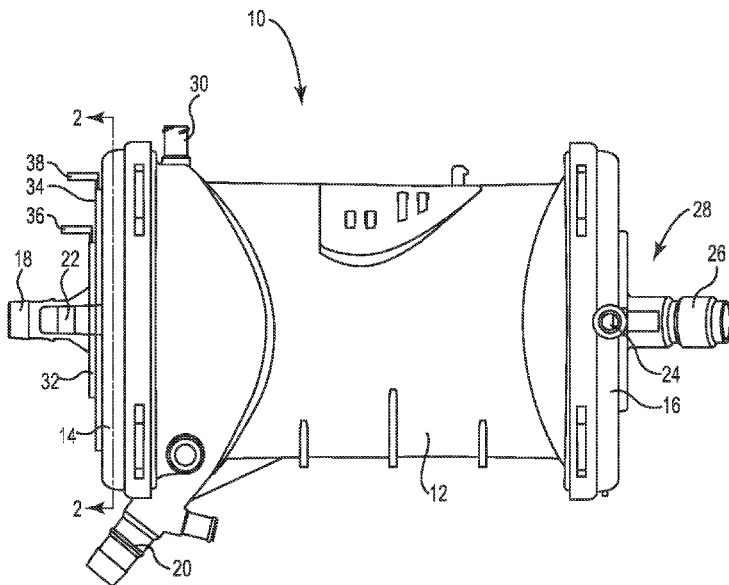

Fig. 1

(57) Abstract: Described is a gas exchanger with a restriction element or elements to reduce gas exchange as desired to avoid hypo-capnia and hyper-oxygenation in small patients. The gas exchanger includes a gas exchanger housing with an outer wall and a core which defines an inner wall and having a blood inlet for receiving a blood supply and a blood outlet. The gas exchanger also includes: a hollow fiber bundle disposed within the housing between the core and the outer wall; and a gas inlet compartment for receiving an oxygen supply and directing the oxygen supply to first ends of the hollow fiber bundle, wherein the gas inlet compartment includes at least one restriction element configured to allow the oxygen supply to reach only a portion of the hollow fiber bundle.

WO 2016/181189 A1

BLOOD GAS EXCHANGER WITH RESTRICTION ELEMENT OR ELEMENTS TO REDUCE GAS EXCHANGE

TECHNICAL FIELD

[0001] The present invention relates generally to extracorporeal fluid circuits. More specifically, the invention relates to an oxygenator, or gas exchanger, used in such circuits having at least one restriction element that allows for a reduction in gas exchange to avoid hypo-capnia and hyper-oxygenation in small patients.

BACKGROUND

[0002] The disclosure pertains generally to blood processing units used in blood perfusion systems. Blood perfusion entails encouraging blood through the vessels of the body. For such purposes, blood perfusion systems typically entail the use of one or more pumps in an extracorporeal circuit that is interconnected with the vascular system of a patient. Cardiopulmonary bypass surgery typically requires a perfusion system that provides for the temporary cessation of the heart to create a still operating field by replacing the function of the heart and lungs. Such isolation allows for the surgical correction of vascular stenosis, valvular disorders, and congenital heart defects. In perfusion systems used for cardiopulmonary bypass surgery, an extracorporeal blood circuit is established that includes at least one pump and an oxygenation device to replace the functions of the heart and lungs.

[0003] More specifically, in cardiopulmonary bypass procedures oxygen-poor blood, i.e., venous blood, is gravity-drained or vacuum suctioned from a large vein entering the heart or other veins in the body (e.g., femoral) and is transferred through a venous line in the extracorporeal circuit. The venous blood is pumped to an oxygenator that provides for oxygen transfer to the blood. Oxygen may be introduced into the blood by transfer across a membrane or, less frequently, by bubbling oxygen through the blood. Concurrently, carbon dioxide is removed across the membrane. The oxygenated blood is filtered and then returned through an arterial line to the aorta, femoral artery, or other artery.

[0004] In small patients, particularly neonatal patients, with low blood volumes, if a standard sized oxygenator is used during cardiopulmonary bypass, excessive carbon dioxide removal and excessive oxygen delivery can result. Excessive carbon dioxide removal can lead to a deleterious change of pH of the blood out of the physiological levels. Avoiding excessive carbon dioxide removal and excessive oxygen delivery is, therefore, desired.

SUMMARY

[0005] Example 1 of the present invention is a gas exchanger comprising: a gas exchanger housing including an outer wall and a core which defines an inner wall and having a blood inlet for receiving a blood supply and a blood outlet, the gas exchanger housing defining a gas exchanger volume; a hollow fiber bundle disposed within the housing between the core and the outer wall, the hollow fiber bundle comprising hollow gas permeable fibers, each fiber having first and second ends and a hollow interior; and a gas inlet compartment for receiving an oxygen supply and directing the oxygen supply to the first ends of the hollow gas permeable fibers; wherein the gas inlet compartment includes at least one restriction element configured to allow the oxygen supply to reach only a portion of the hollow gas permeable fibers.

[0006] Example 2 is the gas exchanger of Example 1, wherein the at least one restriction element comprises a gasket.

[0007] Example 3 is the gas exchanger of Example 1, wherein the at least one restriction element is moveable such that the at least one restriction element can assume a first position that is opened in order to allow the oxygen supply to reach all of the hollow gas permeable fibers and a second position that is closed such that the oxygen supply only reaches a portion of the hollow gas permeable fibers.

[0008] Example 4 is the gas exchanger of Example 1, wherein the gas exchanger includes at least two restriction elements and the at least two restriction elements are concentrically arranged.

[0009] Example 5 is the gas exchanger of Example 1, wherein the gas exchanger housing is tubular in shape, the gas inlet compartment includes a gas inlet

that is located at or near the center of the lid, and the at least one restriction element concentrically surrounds the gas inlet.

[0010] Example 6 is the gas exchanger of Example 1, wherein 50% of the fiber bundle is provided with oxygen supply for a small, neonatal patient.

[0011] Example 7 is a gas exchanger comprising: a gas exchanger housing including an outer wall, at least one lid, and a core which defines an inner wall and having a blood inlet for receiving a blood supply and a blood outlet, the gas exchanger housing defining a gas exchanger volume; a hollow fiber bundle disposed within the housing between the core and the outer wall, the hollow fiber bundle comprising hollow gas permeable fibers, each fiber having first and second ends and a hollow interior, wherein the first ends of the hollow gas permeable fibers are located in a first potting that is located at or near the lid; and a gas inlet compartment including a gas inlet for receiving an oxygen supply and directing the oxygen supply to the first ends of the hollow gas permeable fibers; wherein the gas inlet compartment includes at least one restriction element that concentrically surrounds the gas inlet, wherein the one or more restriction elements are moveable such that the one or more restriction elements can assume a first position that is open in order to allow the oxygen supply to reach all of the first ends of the hollow gas permeable fibers and a second position that is compressed against the potting such that the oxygen supply only reaches a portion of the hollow gas permeable fibers.

[0012] Example 8 is the gas exchanger of Example 7, further comprising at least one rigid lever that is connected to the at least one restriction element and that is configured to move the at least one restriction element between the first and second positions.

[0013] Example 9 is the gas exchanger of Example 7, wherein the gas inlet compartment is located within the at least one lid.

[0014] Example 10 is the gas exchanger of Example 7, wherein the oxygenator includes at least two restriction elements and the at least two restriction elements are concentrically arranged.

[0015] Example 11 is the gas exchanger of Example 7 wherein the at least one restriction element comprises a gasket.

[0016] Example 12 is the gas exchanger of Example 7, wherein 50% of the fiber bundle is provided with oxygen supply for a small, neonatal patient.

[0017] Example 13 is a method of oxygenation comprising: providing a gas exchanger comprising: a gas exchanger housing including an outer wall and a core which defines an inner wall and having a blood inlet for receiving a blood supply and a blood outlet, the gas exchanger housing defining a gas exchanger volume; a gas inlet compartment for receiving an oxygen supply and directing the oxygen supply to the first ends of the hollow gas permeable fibers; wherein the gas inlet compartment includes at least one restriction element configured to allow the oxygen supply to reach only a portion of the hollow gas permeable fibers; activating the at least one restriction element; causing the oxygen supply to flow through the hollow interior of the portion of the hollow gas permeable fibers; delivering blood to the gas exchanger through the blood inlet; causing the blood to flow through the gas exchanger housing over the exterior of the hollow gas permeable fibers; and discharging the blood through the blood outlet.

[0018] Example 14 is the method of Example 13, wherein the at least one restriction element comprises a gasket.

[0019] Example 15 is the method of Example 13, wherein the at least one restriction element is moveable such that the at least one restriction element can assume a first position that is open in order to allow the oxygen supply to reach all of the hollow gas permeable fibers and a second position that is closed such that the oxygen supply only reaches a portion of the hollow gas permeable fibers.

[0020] Example 16 is the method of Example 15, wherein activating the at least one restriction element comprises moving the at least one restriction element to the second position.

[0021] Example 17 is the method of Example 13, wherein the gas exchanger includes at least two restriction elements and the at least two restriction elements are concentrically arranged.

[0022] Example 18 is the method of Example 13, wherein the gas exchanger housing is tubular in shape, the gas inlet compartment includes a gas inlet that is

located at or near the center of the lid, and the at least one restriction element concentrically surrounds the gas inlet.

[0023] Example 19 is the method of Example 13, wherein the at least one restriction element concentrically surrounds the gas inlet, wherein the one or more restriction elements are moveable such that the one or more restriction elements can assume a first position that is open in order to allow the oxygen supply to reach all of the first ends of the hollow gas permeable fibers and a second position that is compressed against the potting such that the oxygen supply only reaches a portion of the hollow gas permeable fibers.

[0024] Example 20 is the method of Example 13, wherein 50% of the fiber bundle is provided with oxygen supply for a small, neonatal patient.

[0025] While multiple embodiments are disclosed, still other embodiments of the present invention will become apparent to those skilled in the art from the following detailed description, which shows and describes illustrative embodiments of the invention. Accordingly, the drawings and detailed description are to be regarded as illustrative in nature and not restrictive.

BRIEF DESCRIPTION OF THE DRAWINGS

[0026] Figure 1 is a perspective view of an oxygenator, or gas exchanger, in accordance with an embodiment of the invention.

[0027] Figure 2 is a cross-sectional view of the oxygenator of Figure 1 taken at 2-2.

[0028] Figure 3 is a partial cross-sectional view of an oxygenator in accordance with an embodiment of the invention.

[0029] Figure 4 is a partial cross-sectional view of an oxygenator in accordance with an embodiment of the invention.

[0030] Figure 5 is a partial cross-sectional view of an oxygenator in accordance with an embodiment of the invention.

[0031] Figure 6 is a schematic cross-sectional view of an oxygenator in accordance with an embodiment of the invention.

[0032] Figure 7 is a cross-sectional view of an embodiment of an oxygenator in accordance with an embodiment of the invention.

[0033] Figure 8A is a partial cross-sectional view of an oxygenator in accordance with an embodiment of the invention.

[0034] Figure 8B is a cross-sectional view of the oxygenator of Figure 8A taken at B-B.

[0035] While the invention is amenable to various modifications and alternative forms, specific embodiments have been shown by way of example in the drawings and are described in detail below. The intention, however, is not to limit the invention to the particular embodiments described. On the contrary, the invention is intended to cover all modifications, equivalents, and alternatives falling within the scope of the invention as defined by the appended claims.

DETAILED DESCRIPTION

[0036] The disclosure pertains to an oxygenator (also commonly referred to as a gas exchanger). In some embodiments, an oxygenator may be used in an extracorporeal blood circuit. An extracorporeal blood circuit, such as may be used in a bypass procedure, may include several different elements such as a heart-lung machine, a blood reservoir, a heat exchanger, as well as an oxygenator. In various embodiments, the gas exchanger, or oxygenator, includes one or more restriction elements that allow for a reduction in gas transfer performance of the oxygenator in order to avoid hypo-capnia and hyper-oxygenation in patients, particularly small or neonatal patients. In various embodiments, one or more restriction elements are configured to be activated to allow an oxygen supply to reach only a portion of hollow gas permeable fibers, thereby reducing the amount of gas exchange performed by the oxygenator.

[0037] Figure 1 is a schematic illustration of an oxygenator 10 (or “gas exchanger”). While the internal components are not visible in the illustration, the oxygenator 10 will include a fiber bundle inside where gas exchange takes place. The oxygenator 10 includes a housing 12, a first end cap 14 that is secured to the housing 12 and a second end cap 16 that is secured to the housing 12. In some embodiments,

the housing 12 may include other structures that enable attachment of the housing 12 to other devices. While the housing 12 is largely cylindrical in shape, in some embodiments, the housing 12 may have a triangular, rectangular or other parallelogram cross-sectional shape, for example. The fiber bundle inside may have generally the same sectional shape as the housing 12 or may have a different sectional shape.

[0038] In some embodiments, a blood inlet 18 extends into the housing 12 and a blood outlet 20 exits the housing 12. As noted, the oxygenator 10 includes a fiber bundle inside where gas exchange takes place, and thus includes a gas inlet 22 and a gas outlet 24. In some embodiments, the oxygenator 10 may include one or more purge ports 30 that may be used for purging air bubbles from the interior of the oxygenator 10.

[0039] The positions of the blood and gas inlets and outlets, and the purge port 30 in Figure 1 are merely illustrative, as other arrangements and configurations are also contemplated. The purge port 30 may include a valve or a threaded cap. The purge port 30 operates to permit gases (e.g., air bubbles) that exit the blood to be vented or aspirated and removed from the oxygenator 10.

[0040] The housing 12 is preferably made of a rigid plastic in order for the oxygenator 10 to be sturdy yet lightweight. The oxygenator is also preferably mainly transparent, in order to allow the user to see through the oxygenator. Therefore, a preferred material for the oxygenator is a transparent, amorphous polymer. One exemplary type of such a material is a polycarbonate, an ABS (Acrylonitrile Butadiene Styrene), or a co-polyester. Other suitable materials for the housing are also contemplated.

[0041] The fiber bundle (not shown in Figure 1) inside housing 12 may include a number or plurality of microporous hollow fibers through which a gas such as oxygen may flow. The blood may flow around and past the hollow fibers. Due to concentration gradients, oxygen may diffuse through the microporous, semi-permeable hollow fibers into the blood while carbon dioxide may diffuse into the hollow fibers and out of the blood.

[0042] In some embodiments, the hollow fibers are made of semi-permeable membrane including micropores. Preferably, the fibers comprise polypropylene,

polyester, or any other suitable polymer or plastic material. According to various embodiments, the hollow fibers may have an outer diameter of about 0.25 to about 0.3 millimeters. According to other embodiments, the microporous hollow fibers may have a diameter of between about 0.2 and 1.0 millimeters, or more specifically, between about 0.25 and 0.5 millimeters. The hollow fibers may be woven into mats that can range from about 50 to about 200 millimeters in width. In some embodiments, the mats are in a criss-cross configuration. The fiber bundle may be formed of hollow fibers in a variety of winding patterns or structures.

[0043] The hollow fibers are embedded, or sealed, at their ends, in rings of polyurethane resin, for example, which is known as "potting." The fiber bundle of hollow fibers is preferably in a cylindrical shape, but other shapes are also contemplated. The hollow fibers, at first ends, are connected to the first end cap 14 through the potting, with the gas inlet 22 being located in the first end cap 14. At second ends, the hollow fibers are connected to the second end cap 16 through the potting with the gas outlet 24 being located in the second end cap 16. The internal lumens of the fibers are part of the gas pathway that is determined by the first end cap 14, the potting at the first end, the fibers, the second potting and the second end cap 16. The oxygenator chamber is thus defined by the housing as an outer wall and an inner wall or core, together with the pottings at each end of the hollow fibers.

[0044] Oxygen, or a mixture of oxygen and air, known as an oxygen supply, enters through gas inlet 22, passes through the microporous hollow fibers within the fiber bundle, and exits the oxygenator 10 through the gas outlet 24. In some embodiments, the pressure or flow rate of oxygen through the oxygenator may be varied in order to achieve a desired diffusion rate of, for example, carbon dioxide diffusing out of the blood and oxygen diffusing into the blood. In some embodiments, as illustrated, the oxygen flows through the hollow fibers while the blood flows around and over the hollow fibers.

[0045] Differences in concentration of gases between the blood and the oxygen supply produce a diffusive flow of oxygen toward the blood and of carbon dioxide from the blood in the opposite direction. The carbon dioxide reaches the gas outlet 24 and is discharged from the oxygenator 10.

[0046] Any suitable gas supply (or oxygen supply) system may be used with the oxygenator 10 of the invention, in order to deliver an oxygen supply to the fiber bundle or hollow fibers of oxygenator 10. Such a gas supply system may also include, for example, flow regulators, flow meters, a gas blender, an oxygen analyzer, a gas filter, and a moisture trap. Other alternative or additional components in the gas supply system are also contemplated.

[0047] As shown in Figure 1, in some embodiments, structural features may be included within oxygenator 10, and specifically within the first end cap 14 in the figure, that allow an oxygen supply delivered to the oxygenator 10 to reach only a portion of the hollow fibers in the fiber bundle where gas exchange takes place. The restriction elements are configured to be either in an open/inactivated position or a closed/activated position. Moving the at least one restriction element to a closed or activated position will result in an oxygen supply being delivered to only a portion of the hollow fibers in the fiber bundle, and thereby will reduce gas transfer performance. The invention provides a way to decrease gas exchange efficiency of the oxygenator 10 in order to avoid excessive carbon dioxide removal and excessive oxygen delivery to small patients, including neonatal patients.

[0048] Figure 1 shows two restriction elements, first restriction element 32 and second restriction element 34, extending from or within first end cap 14. Although two restriction elements are shown, it is contemplated that any number of restriction elements may be included in the invention such that the size of the first end cap 14 may accommodate the restriction elements. The figure also shows two levers or arms 36 and 38 that extend from or that are coupled or attached to the restriction elements 32, which are used to move the restriction elements between a restricted or closed configuration and an unrestricted or open configuration. Levers or arms 36, 38 are exemplary structural features used to move the restriction elements 32, 34, but other suitable features are also contemplated by the invention.

[0049] Figure 2 is a cross-sectional view of the first end cap 14 shown in the embodiment of the invention in Figure 1 taken at line 2-2. Figure 2 shows that restriction elements 32 and 34 are circular in shape and are concentrically arranged and surrounding gas inlet 22. The circular shape is one exemplary cross-sectional shape of

the restriction elements 32 and 34, but other shapes are also contemplated by the invention. The restriction elements 32, 34 may be gaskets, for example, although other options are also contemplated. Preferably, such gaskets may be made from a silicone or any soft rubber-like material that is able to provide an airtight seal with the polymeric wall of the end cap 14. The silicone or rubber-like material of the restriction elements may also be supported by a rigid material in order to provide rigidity to the gasket and allow it to open and close.

[0050] Figures 3, 4 and 5 are partial cross-sectional perspective views of oxygenator 10. Figure 3 shows the oxygenator 10 with both restriction elements 32, 34, in an open or inactivated configuration. Figure 4 shows the same view as in Figure 3, but with restriction element 32 being in a closed or activated configuration. Figure 5 shows the same view again as in Figures 3 and 4, but with restriction element 34 being in a closed or activated configuration.

[0051] Figures 3, 4 and 5 show cross-sectional views of circular-shaped, restriction elements 32, 34, with rigid levers 36, 38 attached, respectively. The levers 36, 38 that are attached to or an extension of restriction elements 32, 34 are one example of a feature that may be used to move the restriction elements between an inactivated configuration and an activated configuration or vice versa. Other methods or structural features that would allow the restriction elements to be moveable between the two configurations are also contemplated by the invention. For example, a pre-loaded spring (not shown) may be provided in order to move the restriction elements between an open and a closed position. Alternatively, a snap (not shown) may be used to fix the restriction elements in an open or a closed position. Another alternative restriction element is shown in Figures 8A and 8B, and is described in detail below.

[0052] Fiber bundle 40, made up of a plurality of hollow fibers (not shown individually), is shown with a potting 42 on first ends of the hollow fibers. A gas inlet compartment 44 is formed within first end cap 14 between the gas inlet 22 and potting 42. The gas-holding capacity or size of the gas inlet compartment 44 is determined by whether the restriction elements 32, 34 are activated or not.

[0053] Figure 4 shows restriction element 32 in the closed or activated configuration. In order to activate the restriction elements 32, 34, the levers 36, 38 may

be pushed, which moves the restriction elements 32, 34 inward through the gas inlet compartment 44 and towards potting 42. Once the restriction elements 32, 34 are in contact with potting 42, the portion of the gas inlet compartment 44 that is capable of filling with the gas or oxygen supply is reduced. Also, the portion of the hollow fibers in fiber bundle 40 that are able to be reached by the oxygen supply is reduced. Oxygen supply coming in through gas inlet 22 is only able to reach the portion of the hollow fibers in fiber bundle 40 with first end openings that are located between gas inlet 22 and the activated restriction element 32 or 34. Figure 5 shows restriction element 34 in an activated configuration. Compared to Figure 4, where restriction element 32 is activated, a greater number of hollow fibers would be able to receive oxygen supply in the fiber bundle in Figure 5; however it would still only be only a portion of the hollow fibers in the whole fiber bundle 40. Any number and locations of restriction elements may be included in embodiments of the invention, as can be accommodated by the size of the oxygenator 10.

[0054] Figure 6 is a schematic view of a portion of a cross-section of the oxygenator 10 shown in Figure 1. The portion shown includes core 50 of the housing 12, which is not shown in previous figures. In Figure 6, restriction element 34 is activated and in contact with potting 42. Only hollow fibers making up the fiber bundle 40 that are to the interior of the restriction element 34 are active or effective and able to receive oxygen supply. The dotted lines mark the outer perimeter of the active or effective fibers, which are bracketed and marked as 60 in the figure. This configuration is possible if a gas inlet connector (not shown) is to the interior of restriction element 34. If, however, the gas inlet connector (not shown) is to the exterior of the restriction element 34, then the hollow fibers of the fiber bundle that are to the exterior of the restriction element 34 would be active or effective and able to receive oxygen supply.

[0055] Figure 7 is a cross-sectional view of another embodiment of an oxygenator 100 of the present invention. The oxygenator of the present invention can stand alone or, as shown, oxygenator 100 can include an integrated heat exchanger 118. In the particular embodiment shown, blood flow through the heat exchanger portion 118 is circumferential, while blood flow through the gas exchanger portion is longitudinal. Other arrangements are contemplated, however. As shown in Figure 7,

the oxygenator 100 includes a housing 102, a first end cap 104, and a second end cap 106. The oxygenator 100 includes a blood inlet 108 and a blood outlet 110. A gas inlet 112 permits oxygen to be provided to the gas exchanger portion, while a gas outlet 114 permits gases to exit the oxygenator 100.

[0056] The oxygenator 100 includes a heat exchanger core 116, a heat exchanger element 118 disposed about the heat exchanger core 116, a cylindrical shell 120 disposed about the heat exchanger element 118 and a gas exchanger element 122, all disposed inside the outer shell or housing 102. The heat exchanger element 118 and the gas exchanger element 122 may each include a number of hollow fibers as discussed with respect to oxygenator 10 (Figures 1-6). In some embodiments, the housing 102 includes an annular portion 124 that is in fluid communication with the blood outlet 110.

[0057] In use, blood enters the blood processing apparatus or oxygenator 100 through the blood inlet 108 and passes into the heat exchanger core 116. The blood fills the heat exchanger core 116 and exits through an elongate core aperture 126 and thus enters the heat exchanger element 118. In some embodiments, the heat exchanger core 116 includes a single elongate core aperture 126, while in other embodiments, the heat exchanger core 116 may include two or more elongate core apertures 126. In some embodiments, the elongate aperture 126 allows or directs blood to flow through the heat exchanger element 118 in a circumferential direction.

[0058] As shown in Figure 7, according to some embodiments, the cylindrical shell 120 includes an elongate collector or channel 127. The channel 127 may be disposed at a location substantially diametrically opposed to the location of the elongate core aperture 126. Locating the channel 127 substantially opposite the location of the core aperture 126 causes blood to flow in a generally circumferential flow pattern within the heat exchanger element 118. The channel 127 may extend from between about 1 and about 15 degrees about the circumference of the cylindrical shell 120. In one exemplary embodiment, the channel 127 extends about 5 degrees about the circumference. The blood flow path can be circumferential, as described. Some other alternatives to the blood flow path, however, include radial or longitudinal flow or combinations of circumferential, radial and/or longitudinal flow.

[0059] After blood passes through the heat exchanger element 118, it collects in the channel 127 and flows into an annular shell aperture 128. The shell aperture 128, in various embodiments, extends entirely or substantially around the circumference of the cylindrical shell 120, such that blood exits the inner cylindrical shell 120 around the entire or substantially the entire circumference of the cylindrical shell 120. In some embodiments, the radially disposed shell aperture 128 may be located near an end of the oxygenator 100 that is opposite the blood outlet 110, thereby causing the blood to flow through the heat exchanger element 118 in a longitudinal direction. Blood then collects in the annular portion 124 before exiting the oxygenator 100 through the blood outlet 110.

[0060] At least one restriction element 132, as in the embodiment shown in Figure 7, would be located radially outward from, and circumferentially surround, the gas inlet 112. Restriction element 132 would include a lever or another activation member 136 that would allow the restriction element 132 to be moved to contact the potting of the fiber bundle in order to reduce the number of hollow fibers in the fiber bundle of the gas exchanger element 122 that receive oxygen supply.

[0061] The embodiment shown in Figure 7 is one exemplary integrated oxygenator and heat exchanger. The oxygenator of the present invention may or may not include a heat exchanger component. Also, other embodiments of integrated oxygenators and heat exchangers are contemplated by the invention that may include other configurations and blood flow patterns. The embodiment shown in Figure 7 is one example.

[0062] Figures 8A and 8B show two different cross-sections of another embodiment of the gas exchanger, or oxygenator, of the present invention. Figure 8A is a partial cross-section of the gas exchanger 200 taken longitudinally, and Figure 8B is a cross-section taken at line B-B from Figure 8A. The oxygenator 200 has a housing 212 surrounding a plurality of hollow fibers 240 (not shown individually). A potting is shown by 210. One end cap 214 is shown that includes a gas inlet 222. A generally circular-shaped restriction element 250 is included in the end cap 214. The restriction element 250 is able to be rotated in two directions as shown by the arrow on Figure 8B. Restriction element 250 includes a plurality of holes 243 or passages that may be lined

up or not lined up with holes or passages 233 in stationary element 232 that may be located either radially inward or outward from restriction element 250. Depending on whether or not the whole fiber bundle or only a portion of the fiber bundle is desired to be used for a particular patient, the holes 243 and 233 may or may not be lined up. If the holes 243 and 233 are lined up then gas will flow through the whole fiber bundle. If the holes 233 and 243 are not lined up, then the gas may only reach the fibers in the portion of the fiber bundle that is located radially outward from the restriction element 250. This is one more exemplary embodiment of the gas exchanger of the present invention.

[0063] The present invention allows the use of one device for a range of sizes of neonatal patients. The device allows for ease in setting appropriate gas exchange performances based on specific patient dimensions, thereby avoiding excess carbon dioxide removal, particularly for very small patients (size 5 kg or less, for example). Gas exchange may be set based on the amount of fiber bundle that is active or used, based on whether or not a restriction element is activated or not. With no restriction elements activated, the percentage of the fiber bundle that is active or used is about 100%. If one restriction element is activated, the percentage of the fiber bundle that is active or used is about 50%, for example. If there are two restriction elements included in the device, then the percentage of active fiber bundle could be either about 33% or about 66%, for example, depending on which restriction element is activated. The percentages of fiber bundle that may be active or used may be varied as well as the number and location of the restriction element or elements.

[0064] Another embodiment of the invention is a method of oxygenation or oxygenating blood. The steps may comprise providing an oxygenator comprising: an oxygenator housing including an outer wall and a core which defines an inner wall and having a blood inlet for receiving a blood supply and a blood outlet, the oxygenator housing defining an oxygenator volume; a hollow fiber bundle disposed within the housing between the core and the outer wall, the hollow fiber bundle comprising hollow gas permeable fibers, each fiber having first and second ends and a hollow interior; a gas inlet compartment for receiving an oxygen supply and directing the oxygen supply to the first ends of the hollow gas permeable fibers; wherein the gas inlet compartment

includes at least one restriction element configured to allow the oxygen supply to reach only a portion of the hollow gas permeable fibers. The oxygenator may alternatively be any embodiment as described, suggested or shown herein, or any other suitable oxygenator. The method may further comprise: activating at least one restriction element; causing an oxygen supply to flow through the hollow interior of the portion of the hollow gas permeable fibers; delivering blood to the oxygenator through the blood inlet; causing the blood to flow through the oxygenation housing over the exterior of the hollow gas permeable fibers; and discharging the blood through the blood outlet. Other methods of oxygenation are also contemplated by the invention.

[0065] Various modifications and additions can be made to the exemplary embodiments discussed without departing from the scope of the present invention. For example, while the embodiments described above refer to particular features, the scope of this invention also includes embodiments having different combinations of features and embodiments that do not include all of the described features. Accordingly, the scope of the present invention is intended to embrace all such alternatives, modifications, and variations as fall within the scope of the claims, together with all equivalents thereof.

CLAIMS

We claim:

1. A gas exchanger comprising:
 - a gas exchanger housing including an outer wall and a core which defines an inner wall and having a blood inlet for receiving a blood supply and a blood outlet, the gas exchanger housing defining a gas exchanger volume;
 - a hollow fiber bundle disposed within the housing between the core and the outer wall, the hollow fiber bundle comprising hollow gas permeable fibers, each fiber having first and second ends and a hollow interior; and
 - a gas inlet compartment for receiving an oxygen supply and directing the oxygen supply to the first ends of the hollow gas permeable fibers;wherein the gas inlet compartment includes at least one restriction element configured to allow the oxygen supply to reach only a portion of the hollow gas permeable fibers.
2. The gas exchanger of claim 1, wherein the at least one restriction element comprises a gasket.
3. The gas exchanger of claim 1, wherein the at least one restriction element is moveable such that the at least one restriction element can assume a first position that is opened in order to allow the oxygen supply to reach all of the hollow gas permeable fibers and a second position that is closed such that the oxygen supply only reaches a portion of the hollow gas permeable fibers.
4. The gas exchanger of claim 1, wherein the gas exchanger includes at least two restriction elements and the at least two restriction elements are concentrically arranged.

5. The gas exchanger of claim 1, wherein the gas exchanger housing is tubular in shape, the gas inlet compartment includes a gas inlet that is located at or near the center of the lid, and the at least one restriction element concentrically surrounds the gas inlet.

6. The gas exchanger of claim 1, wherein 50% of the fiber bundle is provided with oxygen supply for a small, neonatal patient.

7. A gas exchanger comprising:

a gas exchanger housing including an outer wall, at least one lid, and a core which defines an inner wall and having a blood inlet for receiving a blood supply and a blood outlet, the gas exchanger housing defining a gas exchanger volume;

a hollow fiber bundle disposed within the housing between the core and the outer wall, the hollow fiber bundle comprising hollow gas permeable fibers, each fiber having first and second ends and a hollow interior, wherein the first ends of the hollow gas permeable fibers are located in a first potting that is located at or near the lid; and

a gas inlet compartment including a gas inlet for receiving an oxygen supply and directing the oxygen supply to the first ends of the hollow gas permeable fibers;

wherein the gas inlet compartment includes at least one restriction element that concentrically surrounds the gas inlet, wherein the one or more restriction elements are moveable such that the one or more restriction elements can assume a first position that is open in order to allow the oxygen supply to reach all of the first ends of the hollow gas permeable fibers and a second position that is compressed against the potting such that the oxygen supply only reaches a portion of the hollow gas permeable fibers.

8. The gas exchanger of claim 7, further comprising at least one rigid lever that is connected to the at least one restriction element and that is configured to move the at least one restriction element between the first and second positions.

9. The gas exchanger of claim 7, wherein the gas inlet compartment is located within the at least one lid.

10. The gas exchanger of claim 7, wherein the oxygenator includes at least two restriction elements and the at least two restriction elements are concentrically arranged.

11. The gas exchanger of claim 7, wherein the at least one restriction element comprises a gasket.

12. The gas exchanger of claim 7, wherein 50% of the fiber bundle is provided with oxygen supply for a small, neonatal patient.

13. A method of oxygenation comprising:

providing a gas exchanger comprising:

a gas exchanger housing including an outer wall and a core which defines an inner wall and having a blood inlet for receiving a blood supply and a blood outlet, the gas exchanger housing defining a gas exchanger volume;

a hollow fiber bundle disposed within the housing between the core and the outer wall, the hollow fiber bundle comprising hollow gas permeable fibers, each fiber having first and second ends, hollow interior and an exterior; and

a gas inlet compartment for receiving an oxygen supply and directing the oxygen supply to the first ends of the hollow gas permeable fibers;

wherein the gas inlet compartment includes at least one restriction element configured to allow the oxygen supply to reach only a portion of the hollow gas permeable fibers;

activating the at least one restriction element;

causing the oxygen supply to flow through the hollow interior of the portion of the hollow gas permeable fibers;

delivering blood to the gas exchanger through the blood inlet;

causing the blood to flow through the gas exchanger housing over the exterior of the hollow gas permeable fibers; and

discharging the blood through the blood outlet.

14. The method of claim 13, wherein the at least one restriction element comprises a gasket.

15. The method of claim 13, wherein the at least one restriction element is moveable such that the at least one restriction element can assume a first position that is open in order to allow the oxygen supply to reach all of the hollow gas permeable fibers and a second position that is closed such that the oxygen supply only reaches a portion of the hollow gas permeable fibers.

16. The method of claim 15, wherein activating the at least one restriction element comprises moving the at least one restriction element to the second position.

17. The method of claim 13, wherein the gas exchanger includes at least two restriction elements and the at least two restriction elements are concentrically arranged.

18. The method of claim 13, wherein the gas exchanger housing is tubular in shape, the gas inlet compartment includes a gas inlet that is located at or near the center of the lid, and the at least one restriction element concentrically surrounds the gas inlet.

19. The method of claim 13, wherein the at least one restriction element concentrically surrounds the gas inlet, wherein the one or more restriction elements are moveable such that the one or more restriction elements can assume a first position that is open in order to allow the oxygen supply to reach all of the first ends of the hollow gas permeable fibers and a second position that is compressed against the potting such that the oxygen supply only reaches a portion of the hollow gas permeable fibers.

20. The method of claim 13, wherein 50% of the fiber bundle is provided with oxygen supply for a small, neonatal patient.

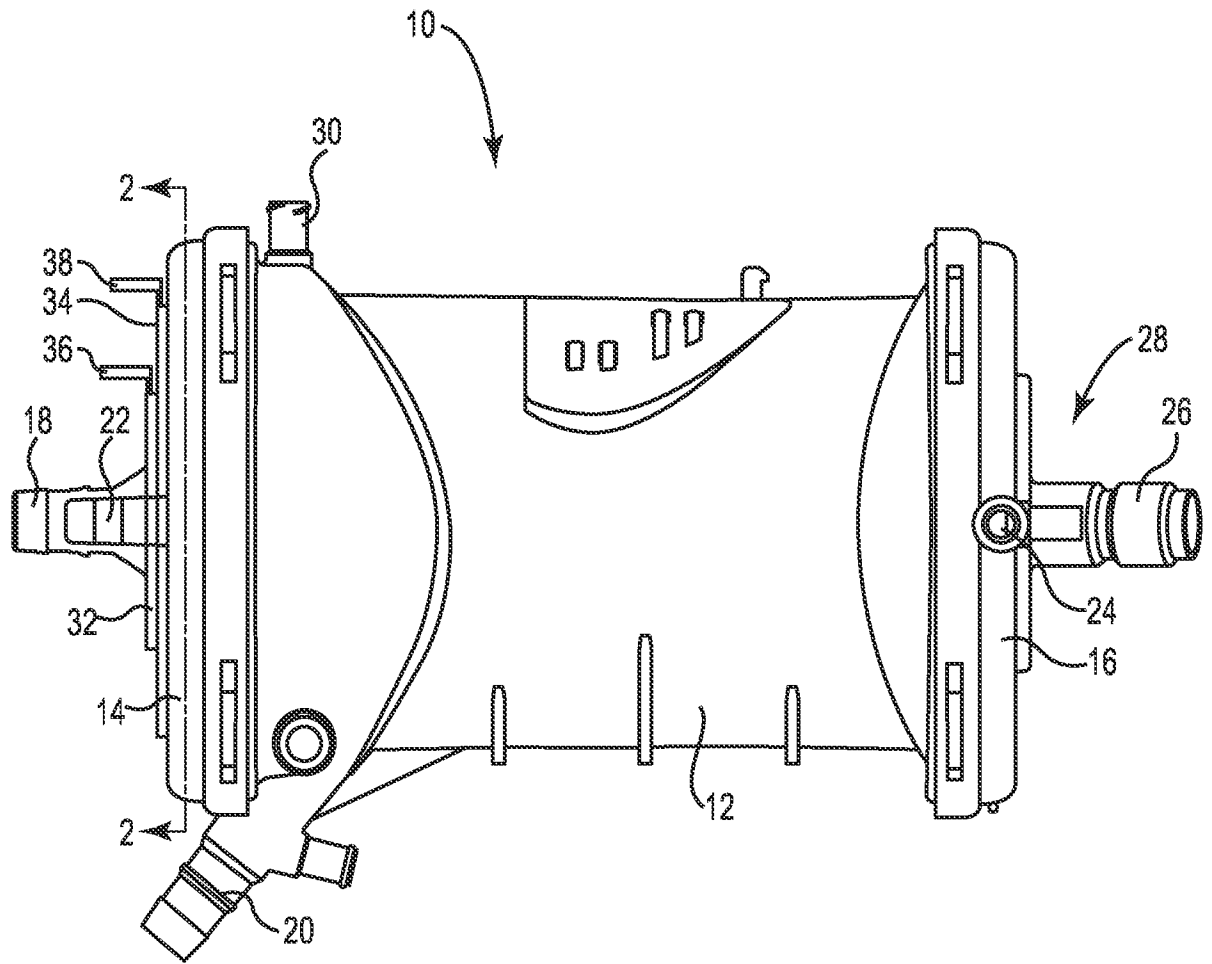

Fig. 1

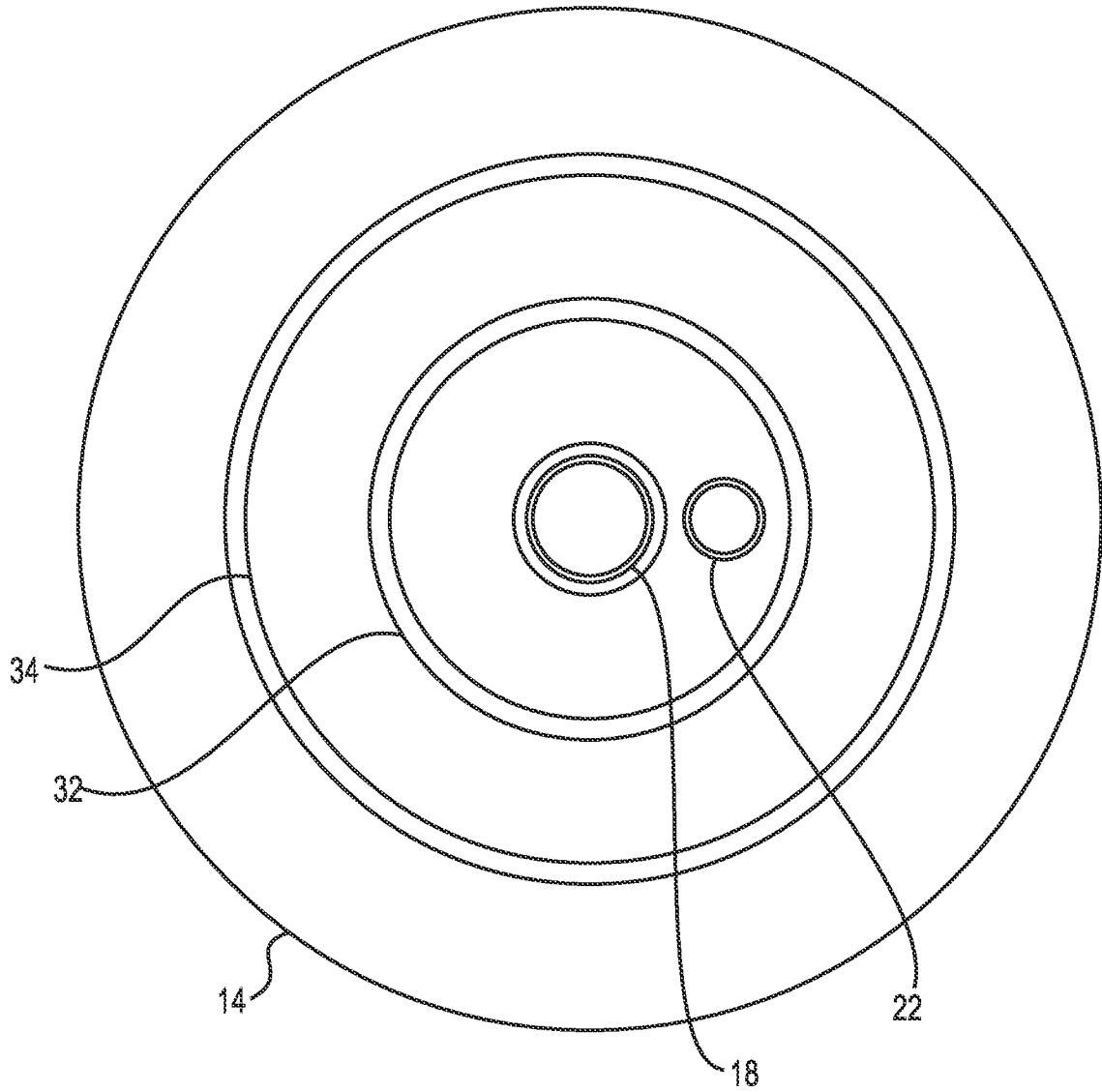

Fig. 2

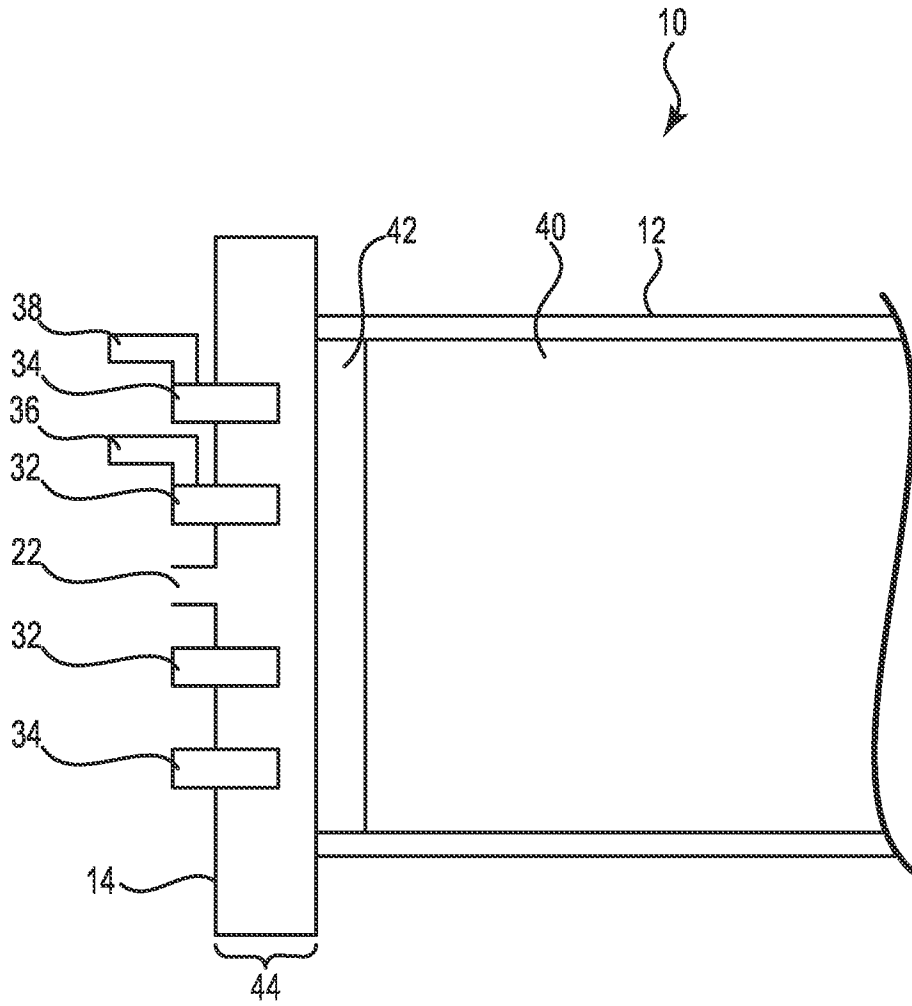

Fig. 3

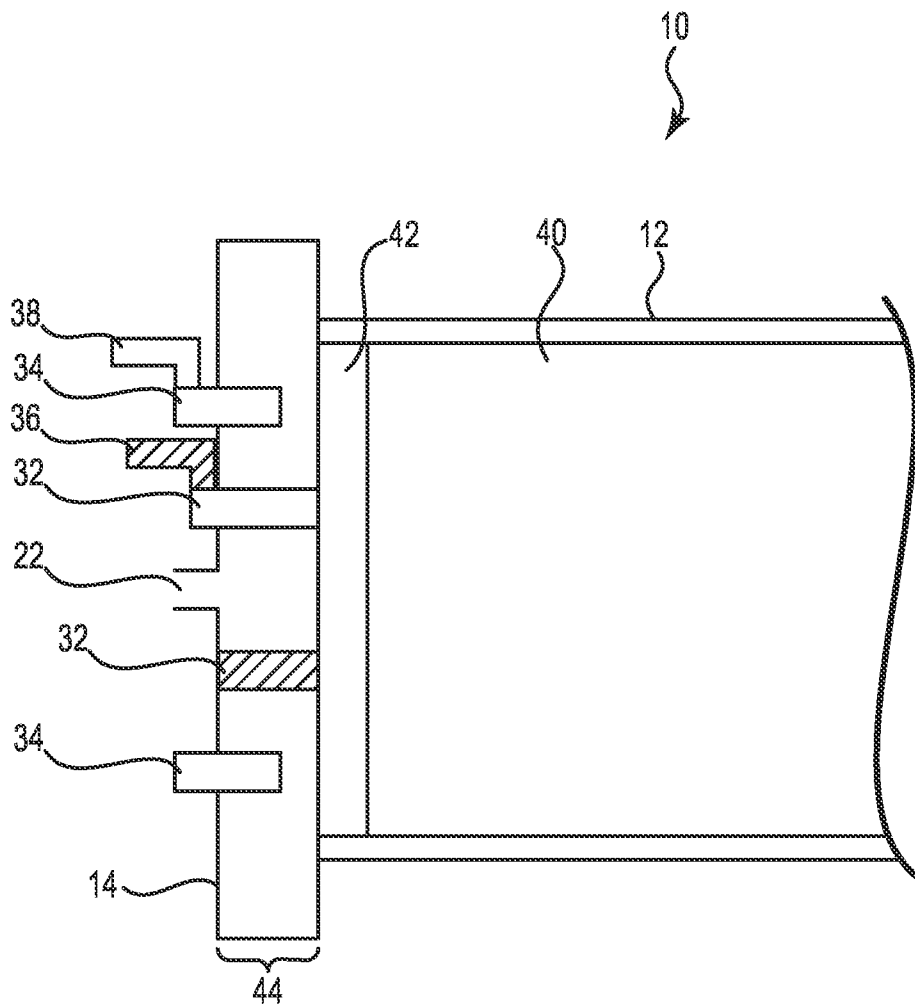

Fig. 4

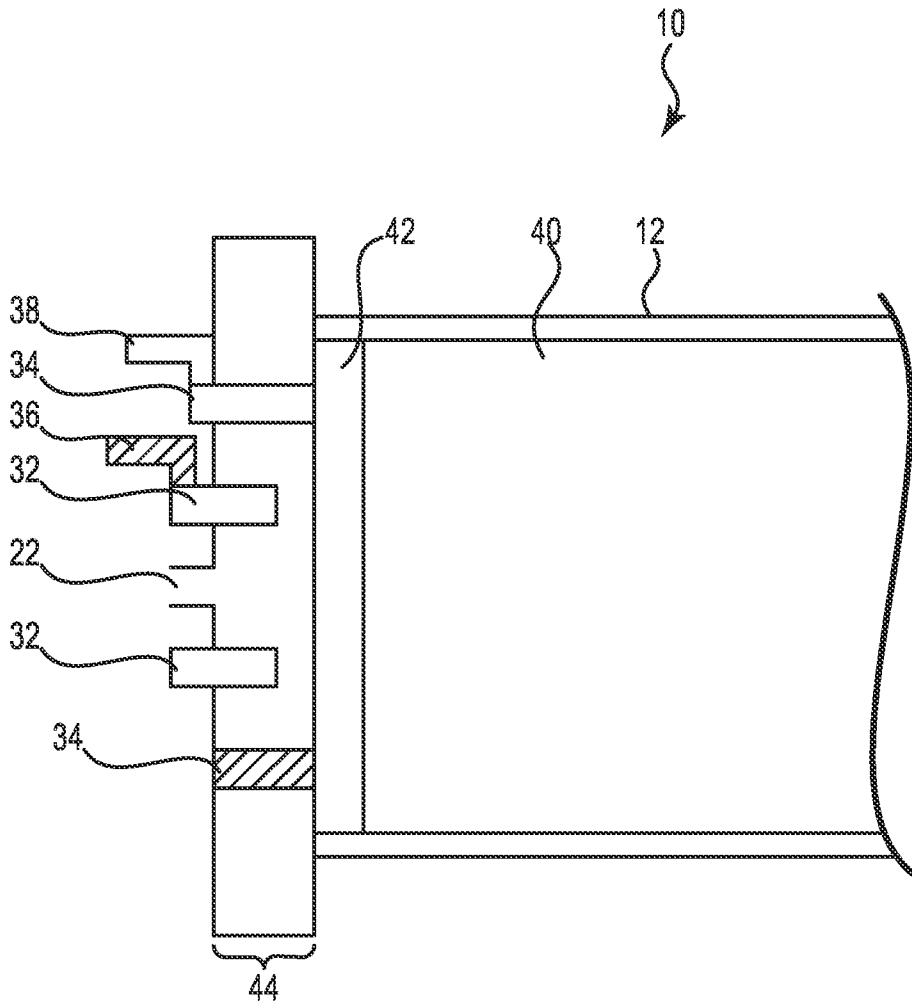

Fig. 5

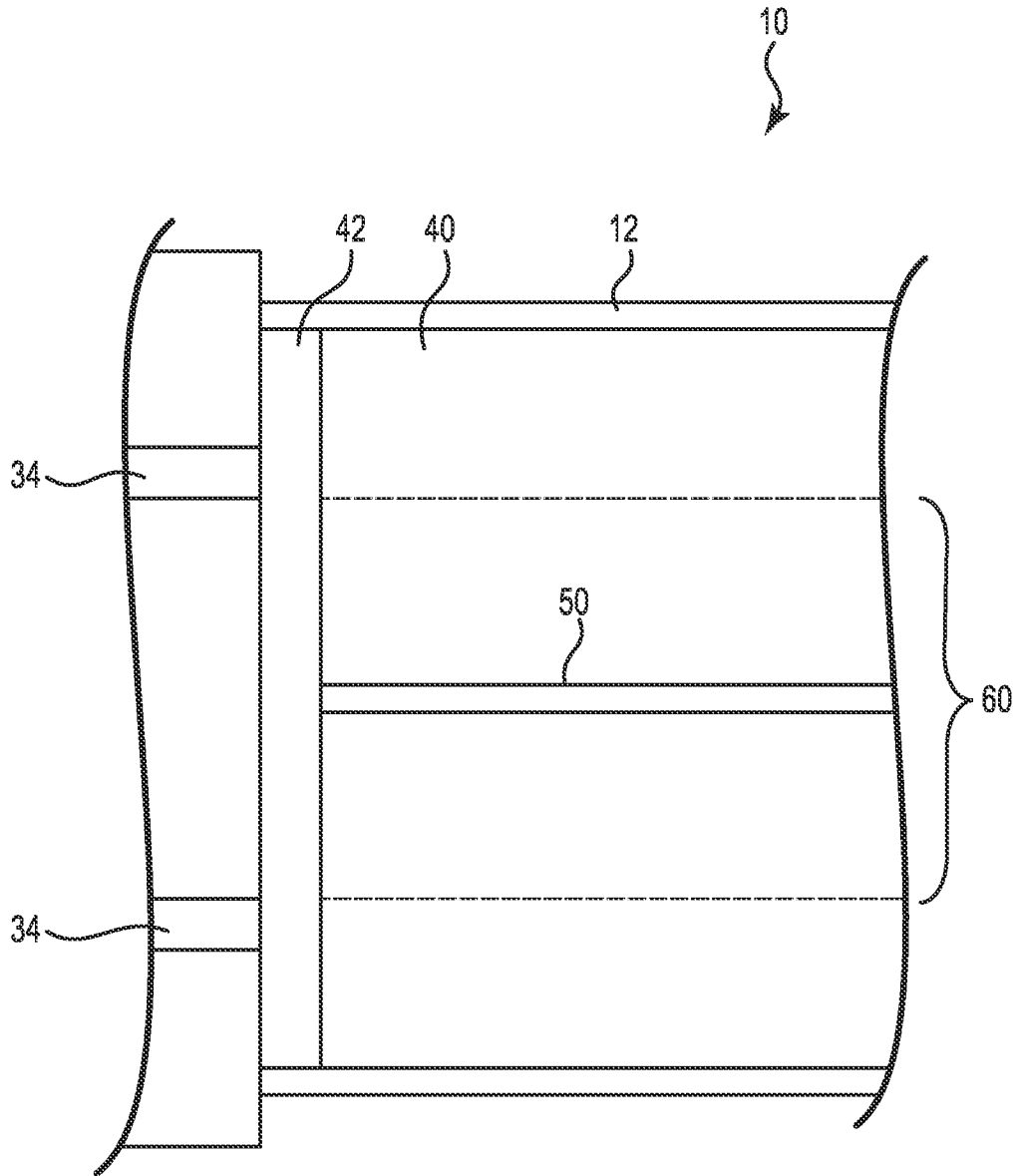

Fig. 6

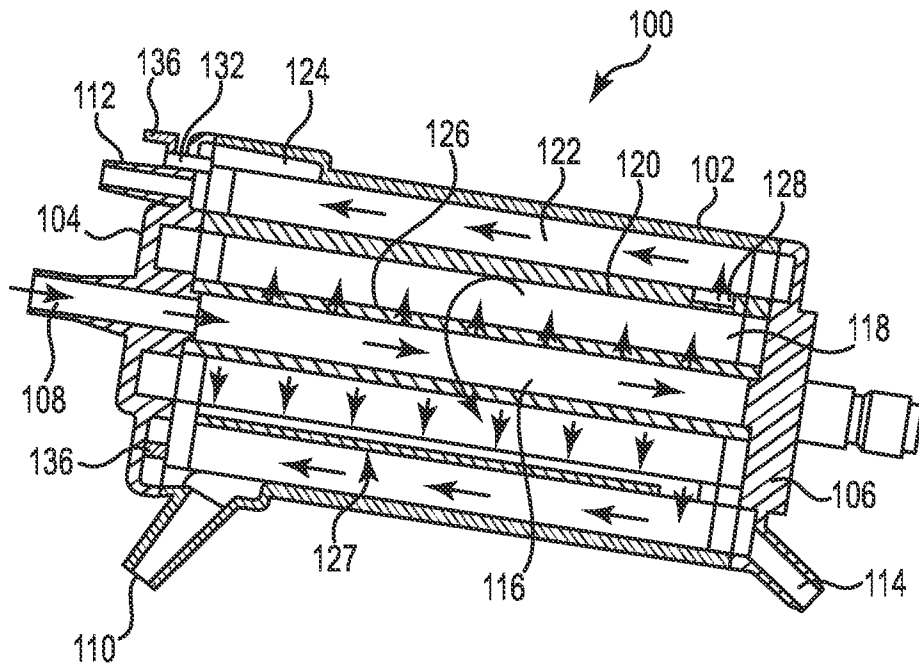

Fig 7

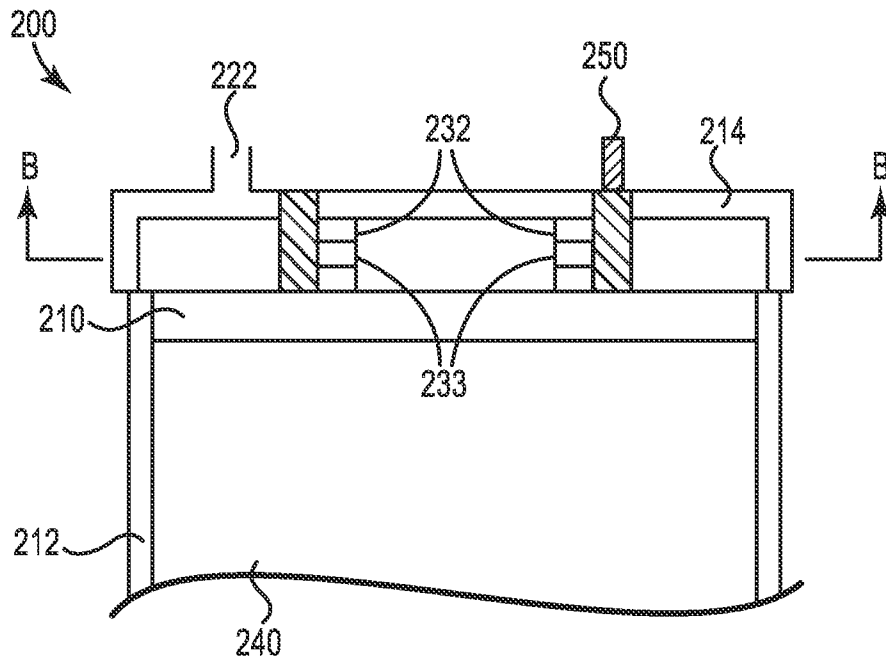

Fig. 8A

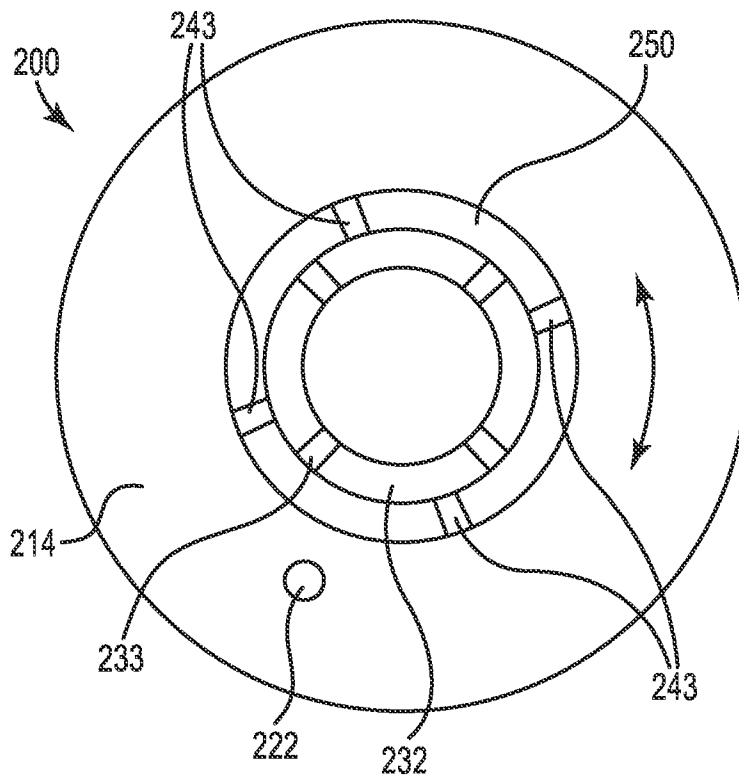

Fig. 8B

INTERNATIONAL SEARCH REPORT

International application No PCT/IB2015/053493

A. CLASSIFICATION OF SUBJECT MATTER INV. A61M1/16 A61M1/26 B01D63/02 ADD.				
According to International Patent Classification (IPC) or to both national classification and IPC				
B. FIELDS SEARCHED				
Minimum documentation searched (classification system followed by classification symbols) A61M B01D				
Documentation searched other than minimum documentation to the extent that such documents are included in the fields searched				
Electronic data base consulted during the international search (name of data base and, where practicable, search terms used) EPO-Internal, WPI Data				
C. DOCUMENTS CONSIDERED TO BE RELEVANT				
Category*	Citation of document, with indication, where appropriate, of the relevant passages	Relevant to claim No.		
X	DE 10 2007 010112 A1 (RWTH AACHEN [DE]) 4 September 2008 (2008-09-04)	1-7,9-12		
A	paragraphs [0023], [0065] - [0068] figure 3	8		

A	DE 10 2010 027973 A1 (ILIAS MEDICAL GMBH [DE]) 20 October 2011 (2011-10-20)	1,7		
paragraphs [0053] - [0070] figures 4, 5				

A	US 2003/175149 A1 (SEARLES BRUCE [US] ET AL) 18 September 2003 (2003-09-18)	1,7		
paragraphs [0009], [0014] figure 1				

A	WO 99/58171 A2 (BAXTER INT [US]) 18 November 1999 (1999-11-18)	1,7		
page 19, line 2 - page 21, line 19 figure 5				

<input type="checkbox"/> Further documents are listed in the continuation of Box C. <input checked="" type="checkbox"/> See patent family annex.				
* Special categories of cited documents : <table style="width: 100%; border: none;"> <tr> <td style="width: 50%; border: none; vertical-align: top;"> "A" document defining the general state of the art which is not considered to be of particular relevance "E" earlier application or patent but published on or after the international filing date "L" document which may throw doubts on priority claim(s) or which is cited to establish the publication date of another citation or other special reason (as specified) "O" document referring to an oral disclosure, use, exhibition or other means "P" document published prior to the international filing date but later than the priority date claimed </td> <td style="width: 50%; border: none; vertical-align: top;"> "T" later document published after the international filing date or priority date and not in conflict with the application but cited to understand the principle or theory underlying the invention "X" document of particular relevance; the claimed invention cannot be considered novel or cannot be considered to involve an inventive step when the document is taken alone "Y" document of particular relevance; the claimed invention cannot be considered to involve an inventive step when the document is combined with one or more other such documents, such combination being obvious to a person skilled in the art "&" document member of the same patent family </td> </tr> </table>			"A" document defining the general state of the art which is not considered to be of particular relevance "E" earlier application or patent but published on or after the international filing date "L" document which may throw doubts on priority claim(s) or which is cited to establish the publication date of another citation or other special reason (as specified) "O" document referring to an oral disclosure, use, exhibition or other means "P" document published prior to the international filing date but later than the priority date claimed	"T" later document published after the international filing date or priority date and not in conflict with the application but cited to understand the principle or theory underlying the invention "X" document of particular relevance; the claimed invention cannot be considered novel or cannot be considered to involve an inventive step when the document is taken alone "Y" document of particular relevance; the claimed invention cannot be considered to involve an inventive step when the document is combined with one or more other such documents, such combination being obvious to a person skilled in the art "&" document member of the same patent family
"A" document defining the general state of the art which is not considered to be of particular relevance "E" earlier application or patent but published on or after the international filing date "L" document which may throw doubts on priority claim(s) or which is cited to establish the publication date of another citation or other special reason (as specified) "O" document referring to an oral disclosure, use, exhibition or other means "P" document published prior to the international filing date but later than the priority date claimed	"T" later document published after the international filing date or priority date and not in conflict with the application but cited to understand the principle or theory underlying the invention "X" document of particular relevance; the claimed invention cannot be considered novel or cannot be considered to involve an inventive step when the document is taken alone "Y" document of particular relevance; the claimed invention cannot be considered to involve an inventive step when the document is combined with one or more other such documents, such combination being obvious to a person skilled in the art "&" document member of the same patent family			
Date of the actual completion of the international search	Date of mailing of the international search report			
6 January 2016	18/01/2016			
Name and mailing address of the ISA/ European Patent Office, P.B. 5818 Patentlaan 2 NL - 2280 HV Rijswijk Tel. (+31-70) 340-2040, Fax: (+31-70) 340-3016	Authorized officer Schlaug, Martin			

INTERNATIONAL SEARCH REPORT

International application No.
PCT/IB2015/053493

Box No. II Observations where certain claims were found unsearchable (Continuation of item 2 of first sheet)

This international search report has not been established in respect of certain claims under Article 17(2)(a) for the following reasons:

1. Claims Nos.: **13-20**
because they relate to subject matter not required to be searched by this Authority, namely:
see FURTHER INFORMATION sheet PCT/ISA/210

2. Claims Nos.:
because they relate to parts of the international application that do not comply with the prescribed requirements to such an extent that no meaningful international search can be carried out, specifically:

3. Claims Nos.:
because they are dependent claims and are not drafted in accordance with the second and third sentences of Rule 6.4(a).

Box No. III Observations where unity of invention is lacking (Continuation of item 3 of first sheet)

This International Searching Authority found multiple inventions in this international application, as follows:

1. As all required additional search fees were timely paid by the applicant, this international search report covers all searchable claims.

2. As all searchable claims could be searched without effort justifying an additional fees, this Authority did not invite payment of additional fees.

3. As only some of the required additional search fees were timely paid by the applicant, this international search report covers only those claims for which fees were paid, specifically claims Nos.:

4. No required additional search fees were timely paid by the applicant. Consequently, this international search report is restricted to the invention first mentioned in the claims; it is covered by claims Nos.:

Remark on Protest

- The additional search fees were accompanied by the applicant's protest and, where applicable, the payment of a protest fee.
- The additional search fees were accompanied by the applicant's protest but the applicable protest fee was not paid within the time limit specified in the invitation.
- No protest accompanied the payment of additional search fees.

FURTHER INFORMATION CONTINUED FROM PCT/ISA/ 210

Continuation of Box II.1

Claims Nos.: 13-20

The subject matter of independent claim 13 together with its dependent claims 14-20 is considered to encompass methods of treatment of the human or animal body by therapy and surgery as explained hereafter. Claim 13 relates to a "method of oxygenation" comprising i.a. the steps of "delivering blood to the gas exchanger through the blood inlet; causing the blood to flow through the gas exchanger housing over the exterior of the hollow gas permeable fibers; and discharging the blood through the blood outlet". It is however within the scope of the present claims that the method is performed while the patient is connected to an extracorporeal blood circuit comprising the gas exchanger (see e.g. paragraphs 2, 3, ...) and as such to treat the organ blood extracorporeally. The subject matter of claims 13-20 was therefore not searched (Article 17(2)(a)(i) / (ii) and Rule 39.1 (iv) PCT) and consequently no opinion will be formulated on the subject matter of those claims (Article 34(4)(a)(i) and Rule 67.1(iv) PCT).

INTERNATIONAL SEARCH REPORT

Information on patent family members

International application No PCT/IB2015/053493

Patent document cited in search report	Publication date	Patent family member(s)	Publication date
DE 102007010112 A1	04-09-2008	CA 2679428 A1	04-09-2008
		DE 102007010112 A1	04-09-2008
		DK 2125069 T3	01-09-2014
		EP 2125069 A1	02-12-2009
		EP 2786772 A1	08-10-2014
		ES 2501916 T3	02-10-2014
		JP 5188513 B2	24-04-2013
		JP 2010518995 A	03-06-2010
		US 2010106072 A1	29-04-2010
		WO 2008104353 A1	04-09-2008

DE 102010027973 A1	20-10-2011	DE 102010027973 A1	20-10-2011
		EP 2560745 A1	27-02-2013
		EP 2560746 A1	27-02-2013
		WO 2011131729 A1	27-10-2011
		WO 2011131734 A1	27-10-2011

US 2003175149 A1	18-09-2003	NONE	

WO 9958171 A2	18-11-1999	AU 3971399 A	29-11-1999
		BR 9910313 A	23-10-2001
		CN 1308549 A	15-08-2001
		EP 1076572 A2	21-02-2001
		EP 1550473 A2	06-07-2005
		US 2001033813 A1	25-10-2001
		WO 9958171 A2	18-11-1999
