



- (51) **International Patent Classification:**  
*H01R 12/70* (2011.01)    *G06K 17/00* (2006.01)
- (21) **International Application Number:**  
PCT/US2011/022312
- (22) **International Filing Date:**  
25 January 2011 (25.01.2011)
- (25) **Filing Language:** English
- (26) **Publication Language:** English
- (30) **Priority Data:**  
12/758,586    12 April 2010 (12.04.2010)    US
- (71) **Applicant (for all designated States except US):** **IDEN-  
TITY STRONGHOLD, LLC** [US/US]; 517 Paul Morris  
Drive, Suite C4-2, Englewood, Florida 34223 (US).
- (72) **Inventor; and**
- (75) **Inventor/Applicant (for US only):** **AUGUSTINOWICZ,  
Walt** [US/US]; 770 Buckskin Court, Englewood, Florida  
34223 (US).
- (74) **Agents:** **NEUSTEL, Michael** et al.; Neustel Law Offices,  
LTD, 2534 South University Drive, Suite 4, Fargo, North  
Dakota 58103 (US).
- (81) **Designated States (unless otherwise indicated, for every  
kind of national protection available):** AE, AG, AL, AM,  
AO, AT, AU, AZ, BA, BB, BG, BH, BR, BW, BY, BZ,  
CA, CH, CL, CN, CO, CR, CU, CZ, DE, DK, DM, DO,

DZ, EC, EE, EG, ES, FI, GB, GD, GE, GH, GM, GT,  
HN, HR, HU, ID, IL, IN, IS, JP, KE, KG, KM, KN, KP,  
KR, KZ, LA, LC, LK, LR, LS, LT, LU, LY, MA, MD,  
ME, MG, MK, MN, MW, MX, MY, MZ, NA, NG, NI,  
NO, NZ, OM, PE, PG, PH, PL, PT, RO, RS, RU, SC, SD,  
SE, SG, SK, SL, SM, ST, SV, SY, TH, TJ, TM, TN, TR,  
TT, TZ, UA, UG, US, UZ, VC, VN, ZA, ZM, ZW.

(84) **Designated States (unless otherwise indicated, for every  
kind of regional protection available):** ARIPO (BW, GH,  
GM, KE, LR, LS, MW, MZ, NA, SD, SL, SZ, TZ, UG,  
ZM, ZW), Eurasian (AM, AZ, BY, KG, KZ, MD, RU, TJ,  
TM), European (AL, AT, BE, BG, CH, CY, CZ, DE, DK,  
EE, ES, FI, FR, GB, GR, HR, HU, IE, IS, IT, LT, LU,  
LV, MC, MK, MT, NL, NO, PL, PT, RO, RS, SE, SI, SK,  
SM, TR), OAPI (BF, BJ, CF, CG, CI, CM, GA, GN, GQ,  
GW, ML, MR, NE, SN, TD, TG).

**Declarations under Rule 4.17:**

— as to non-prejudicial disclosures or exceptions to lack of novelty (Rule 4.17(v))

**Published:**

— with international search report (Art. 21(3))  
— before the expiration of the time limit for amending the claims and to be republished in the event of receipt of amendments (Rule 48.2(h))

(54) **Title:** SMARTCARD CONNECTOR

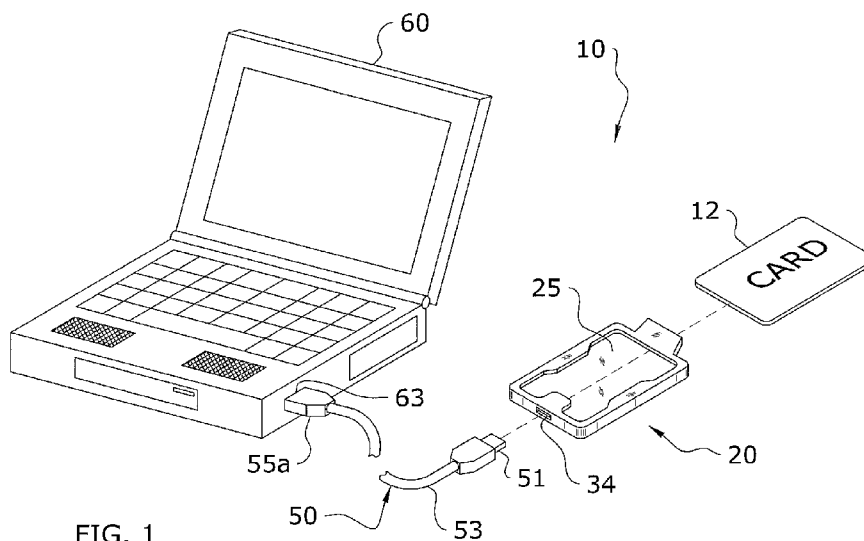

FIG. 1

(57) **Abstract:** A smartcard connector for connecting a smartcard within a card holder to an electronic device. The smartcard connector includes a card holder having a card holding space, a contact pad integral with the card holder and in communicative contact with the card holding space, and an external adapter integral with the card holder and in electrical contact with the contact pad. The adapter is for communicatively connecting a smartcard received and held within the card holding space and in electrical contact with the contact pad to an external data cable. The data cable is also connected to an electrical device, such as a computer, so that the smartcard may be accessed by the computer without removing the smartcard from the card holder. The card holder may also include a battery, display screen, read/write memory, security unit, notification unit, amplification unit, and/or a light.

WO 2011/129904 A1

1  
2  
3  
4  
5  
6  
7  
8  
9  
10  
11  
12  
13  
14  
15  
16  
17  
18  
19  
20  
21  
22  
23  
24  
25  
26  
27  
28  
29  
30

**Smartcard Connector**

**BACKGROUND OF THE INVENTION**

**Field of the Invention**

The present invention relates generally to a smartcard and more specifically it relates to a smartcard connector for efficiently connecting a smartcard and/or badge holder to a computer or other electronic device for transferring and/or accessing data.

**Description of the Related Art**

Any discussion of the related art throughout the specification should in no way be considered as an admission that such related art is widely known or forms part of common general knowledge in the field.

Smartcards including contact, contactless, RFID, etc. are employed in a wide range of applications. The smartcards may be credit card sized and have embedded microchips within or upon the smartcards that store data, such as financial data, health data, or other personal data. Generally, smartcards communicate with other devices through a card reader via contact of the card to the card reader or in a wireless manner, such as by using magnetic waves, radio frequency (RF), infrared, microwave, light, and/or ultraviolet radiation.

As a result of the wireless transmission of data from the smartcard, the smartcard can often times be read without the owner's awareness or permission. Because of the ease in accessing a wireless transmitting smartcard without the owner's awareness or

1 permission, smartcards are often carried within shielding card holders to block any  
2 wireless transmission of data to and from the smartcard.

3

4         When using a card reader that requires contact with the smartcard for  
5 communicating data, it is necessary for the owner of the smartcard to remove the smartcard  
6 from the card holder, wallet, etc. and physically engage the card with the card reader.  
7 Constantly removing the smartcard from the card holder can be tedious and can often result  
8 in the owner of the smartcard forgetting to replace the smartcard back in the respective  
9 holder. Because of the inherent problems with the related art, there is a need for a new and  
10 improved smartcard connector for efficiently connecting a smartcard and/or badge holder  
11 to a computer or other electronic device for transferring and/or accessing data.

12

1  
2  
3  
4  
5  
6  
7  
8  
9  
10  
11  
12  
13  
14  
15  
16  
17  
18  
19  
20  
21  
22  
23  
24  
25  
26  
27  
28  
29

## BRIEF SUMMARY OF THE INVENTION

A system for efficiently connecting a smartcard and/or badge holder to a computer or other electronic device for transferring and/or accessing data. The invention generally relates to a smartcard which includes a card holder having a card holding space, a contact pad connected to the card holder and in communicative contact with the card holding space, and an external adapter connected to the card holder and in electrical contact with the contact pad. The external adapter is for communicatively connecting a smartcard received and held within the card holding space and in electrical contact with the contact pad to an external data transfer cable via connection of the external data transfer cord to the external adapter. The data transfer cable is subsequently connected to an electrical device, such as a computer, so that the smartcard may be accessed by the computer without removing the smartcard from the card holder. The card holder may also include a battery, display screen, read/write memory, security unit, notification unit, amplification unit, and/or a light.

There has thus been outlined, rather broadly, some of the features of the invention in order that the detailed description thereof may be better understood, and in order that the present contribution to the art may be better appreciated. There are additional features of the invention that will be described hereinafter and that will form the subject matter of the claims appended hereto. In this respect, before explaining at least one embodiment of the invention in detail, it is to be understood that the invention is not limited in its application to the details of construction or to the arrangements of the components set forth in the following description or illustrated in the drawings. The invention is capable of other embodiments and of being practiced and carried out in various ways. Also, it is to be understood that the phraseology and terminology employed herein are for the purpose of the description and should not be regarded as limiting.

1                                   **BRIEF DESCRIPTION OF THE DRAWINGS**

2  
3           Various other objects, features and attendant advantages of the present invention  
4 will become fully appreciated as the same becomes better understood when considered in  
5 conjunction with the accompanying drawings, in which like reference characters designate  
6 the same or similar parts throughout the several views, and wherein:

7  
8           FIG. 1 is an upper perspective view of the present invention with the smartcard  
9 exploded in an exemplary manner the card holder and the card holder exploded from a first  
10 end connector of the data transfer cable, wherein the second end connector of the data  
11 transfer cable is connected to the electronic device.

12  
13           FIG. 2 is an upper perspective view of the present invention with the smartcard  
14 inserted within the card holder and the card holder exploded from a first end connector of  
15 the data transfer cable.

16  
17           FIG. 3 is a side sectional view illustrating the smartcard within the card holder  
18 making contact with the contact pad of the card holder.

19  
20           FIG. 4 is an upper perspective view of the present invention illustrating an alternate  
21 second end connector of the data transfer cable being comprised of a secondary smartcard  
22 capable of transferring data from the smartcard within the card holder to be read by the  
23 card holder of the electronic device.

24  
25           FIG. 5 is an exemplary diagram of the card holder having the battery, memory,  
26 security unit, notification unit, amplification unit, display screen, and light.

1  
2  
3  
4  
5  
6  
7  
8  
9  
10  
11  
12  
13  
14  
15  
16  
17  
18  
19  
20  
21  
22  
23  
24  
25  
26  
27  
28  
29  
30

## DETAILED DESCRIPTION OF THE INVENTION

### *A. Overview.*

Turning now descriptively to the drawings, in which similar reference characters denote similar elements throughout the several views, FIGS. 1 through 5 illustrate a smartcard connector **10**, which comprises a card holder **20** having a card holding space **25**, a contact pad **30** connected to the card holder **20** and in communicative contact with the card holding space **25**, and an external adapter **34** connected to the card holder **20** and in electrical contact with the contact pad **30**.

The external adapter **34** is for communicatively connecting a smartcard **12** received and held within the card holding space **25** and in electrical contact with the contact pad **30** to an external data transfer cable **50** via connection of the external data transfer cable **50** to the external adapter **34**. The data transfer cable **50** is subsequently connected to an electronic device **60**, such as a computer, so that the smartcard **12** may be accessed by the computer without removing the smartcard **12** from the card holder **20**.

The card holder **20** may also include a battery **40**, read/write memory **41**, security unit **42**, notification unit **43**, amplification unit **44**, display screen **45**, and/or light **46** in various combinations. Figure 5 illustrates exemplary alternate features of the card holder **20**, such as the battery **40**, memory **41**, security unit **42**, notification unit **43**, amplification unit **44**, display screen **45**, and light **46**. It is appreciated that the alternate features **40-46** are illustrated for example only and no electrical connections are illustrated with the alternate features **40-44** and **46** when, in actuality, the alternate features **40-46** may be connected to each other in various manners required for powering the alternate features **40-46**, accessing the alternate features **40-46**, or for various other reasons. It is appreciated that various methods may be used to connect the alternate features **40-46**, wherein the connection methods are common in the prior art of batteries, read/write memory units, etc. and for this reason are not illustrated in detail.

1 **B. Smartcard.**

2 Various types of communicative smartcards **12** may be utilized with the present  
3 invention. Such smartcards include, but are not limited to RFID smartcards, contactless  
4 smartcards, contact smartcards, RFID passports, and/or any other contact or contactless  
5 device that contains electronic data and may be placed within the card holder **20**. The  
6 smartcard **12** is generally a square shape and credit-card sized; however various shapes and  
7 sizes may be appreciated.

8  
9 The smartcard **12** also preferably includes a contact pad **13** accessible from a  
10 portion of an outer surface of the smartcard **12**. The contact pad **13** is generally metal-  
11 plated and used to transfer data between the smartcard **12** and a card reader **61**. The  
12 contact pad **13** can be various sizes and configurations all which transfer data or allow data  
13 to be accessed from the smartcard **12** upon contact with a mating connector **30** to the  
14 contact pad **13**. The exemplary word "CARD" is illustrated on the smartcard **12** and the  
15 second end connector **55b** auxiliary smartcard in the Figures; it is appreciated that the  
16 exemplary word is simply illustrative and various information or designs may be located  
17 upon either the smartcard **12** or the second end connector **55b**.

18  
19 **C. Card Holder.**

20 The card holder **20** may be structured to hold various types and sizes of smartcards  
21 **12** including but not limited to badges, financial data cards, personal information cards,  
22 passports, etc. U.S. Patent No. 7,635,089 (Device for Shielding Reading of a  
23 Contactless Smartcard) to Augustinowicz et al. and the SECURE BADGEHOLDER  
24 sold by IDENTITY STRONGHOLD illustrate examples of a card holder **20** that may  
25 be utilized within the present invention and is hereby incorporated by reference herein.

26  
27 Generally, the card holder **20** is a handheld item and may include various neck  
28 straps, belt connectors, etc. for holding and carrying the card holder **20**. The card  
29 holder **20** generally includes a first panel **21** and a second panel **22**, wherein the second  
30 panel **22** is movably connected to the first panel **21** via a movable connection (not

1 shown), such as a hinge, etc. A first tab extension may angularly extend from the first  
2 panel **21** and a second tab extension may angularly extend from the second panel **22** to  
3 provide gripping surfaces on which to push inwardly upon and operate the movable  
4 connection to open and close the first panel **21** and the second panel **22** of the card  
5 holder **20** thus providing access to the card holding space **25** therebetween. It is  
6 appreciated that Figure 1 illustrates the smartcard **12** exploded from the card holder **20**  
7 in an exemplary manner; however the card holder **20** may receive the smartcard **12** in  
8 the manner disclosed by incorporated U.S. Patent No. 7,635,089 and the SECURE  
9 BADGEHOLDER sold by IDENTITY STRONGHOLD.

10  
11 The card holding space **25** is generally a suitable size for holding the smartcard  
12 **12**. The card holding space **25** may be completely enclosed by the first panel **21** and  
13 the second panel **22** (when in the closed position) or may be partially open to an  
14 exterior of the card holder **20**. In either case, the card holding space **25** receives the  
15 smartcard **12** and is suited for removably holding the smartcard **12** within the card  
16 holder **20**.

17  
18 The first panel **21** and/or the second panel **22** may include shielding materials  
19 for shielding a wireless transmission of data, such as common with contactless or RFID  
20 smartcards **12**. Alternately, the first panel **21** and/or the second panel **22** may not have  
21 shielding materials. It is appreciated that the card holder **20** may be comprised of  
22 various alternate structures than illustrated all which removably hold a smartcard **12**.  
23 In the case of a dual interface smartcard **12** with contact and contactless interfaces, the  
24 shielding card holder **20** would allow the card holder **20** to continue to shield the  
25 contactless interface of the smartcard **12** while the smartcard **12** is connected to the  
26 electronic device **60** through the data transfer cable **50** and adapter **34**.

27  
28 The card holder **20** includes an internal first signal transfer means **30** adapted to  
29 receive electrical or data signals through contacting the contact pad **13** or in alternate  
30 manners. In the preferred, the first signal transfer means **30** is comprised of a contact

1 pad located internal to the card holder **20** and in communicative contact with the card  
2 holding space **25** so that the contact pad **30** may electrically contact the contact pad **13**  
3 of the smartcard **12** when the smartcard **12** is placed within the card holding space **25**  
4 of the card holder **20**.

5  
6 The contact pad **30** is integrally connected to the card holder **20** and may extend  
7 from the first panel **21**, the second panel **22**, or other elements of the card holder **20** all  
8 which position the contact pad **30** to make electrical contact with the contact pad **13** of  
9 the smartcard **12** when the smartcard **12** is positioned within card holding space **25**.  
10 Like the contact pad **13** of the smartcard **12**, the contact pad **30** of the card holder **20**  
11 may have various metal-coated plates or be structured in various manners to mate with  
12 the contact pad **13** of the smartcard **12** and maintain an electrical or data transfer  
13 connection.

14  
15 The card holder **20** includes an external second signal transfer means **34** adapted  
16 to receive electrical or data signals from the contact pad **30** of the card holder **20**. In  
17 the preferred, the second signal transfer means **34** is comprised of an adapter located  
18 external to the card holder **20** or accessible from an exterior of the card holder **20** and  
19 in electrical and/or communicative contact with the contact pad **30** of the card holder  
20 **20** so that the contact pad **30** of the card holder **20** may electrically connect the contact  
21 pad **13** of the smartcard **12** with the adapter **34** when the smartcard **12** is placed within  
22 the card holding space **25** of the card holder **20**.

23  
24 The adapter **34** may be connected to the first panel **21**, second panel **22**, or other  
25 elements of the card holder **20** all which allow for electrical connection to the contact  
26 pad **30** of the card holder **20**. The adapter **34** may be comprised of a plug or socket  
27 structure and may be adapted to receive USB connectors or various other types of  
28 connectors capable of transferring data from the smartcard **12**. The adapter **34** may be  
29 recessed within the card holder **20** or extend outwardly from the card holder **20**.

30

1 **D. Battery.**

2 The card holder **20** may include a rechargeable battery **40** or other electrical  
3 storage unit contained within the card holder **20** that could charge while the electronic  
4 device **60** is attached to the card holder **20** via the data transfer cable **50**. The battery  
5 **40** could additionally be used for a light **46** or other electronics of the card holder **20**.  
6 Various non rechargeable batteries may also be utilized with the card holder **20** as  
7 appreciated.

8  
9 **E. Memory.**

10 The card holder **20** may also include a built-in flash drive or other read/write  
11 memory chip **41** that would allow data storage in the card holder **20**. Various amounts  
12 of memory **41** may be used with the memory **41** and the memory **41** would preferably  
13 be communicatively connected to the adapter **34** thus allowing the transfer of data to  
14 and/or from the memory **41** through the data transfer cable **50** removably connected to  
15 the adapter **34** of the card holder **20**.

16  
17 **F. Security Unit.**

18 The card holder **20** may also include a security unit **42** to prevent access to the  
19 memory **41** through the adapter **34** unless an authorized smartcard **12** is in electrical  
20 contact with the contact pad **30** of the card holder **20**. The security unit **42** may  
21 alternately or additionally be software within the memory **41** or a biometric sensor for  
22 preventing access to the smartcard **12** through the adapter **34** and/or the memory **41**  
23 without proper identification through biometric means. The biometric sensor embodied  
24 security unit **42** would preferably be located upon the card holder **20** and may be  
25 powered via the electronic device **60** and/or battery **40**. The security unit **42** in  
26 generally may also be powered via the electronic device **60** and/or battery **40**.

27  
28 **G. Notification Unit.**

29 The card holder **20** may also include a notification unit **43** comprising audio  
30 and/or visual notification devices to alert an individual if the contained smartcard **12**

1 within the card holder **20** is being accessed and/or if an RF carrier is present and at the  
2 same frequency as the contained smartcard **12**. Various speakers and/or displays may  
3 be located upon the card holder **20** to provide the audio and/or visual notification as  
4 appreciated. The notification unit **43** may be powered via the rechargeable battery **40**  
5 and/or the connected electronic device **60**.

6  
7 **H. Amplification Unit.**

8 In another embodiment, the card holder **20** may have an amplification unit **44**  
9 that would allow for longer range reading and sending of data from a contactless  
10 smartcard **12** inserted within the card holding space **25** of the card holder **20**. The  
11 amplification unit **44** would generally be connected to the smartcard **12** through the  
12 contact pad **30** of the card holder **20** and may be powered in various manners, such as  
13 by the rechargeable battery **40** and/or the connected electronic device **60**.

14  
15 **I. Display Screen.**

16 The card holder **20** may also include a display screen **45** or window for viewing  
17 and/or displaying smartcard **12** data. The display screen **45** may be electronic or simply a  
18 transparent window to view the data. The display screen **45** would be electrically  
19 connected to the adapter **34** for being powered by the electronic device **60** or  
20 alternately electrically connected to a battery **40**.

21  
22 **J. Light.**

23 The card holder **20** may also include a light **46** for decoration or for visual use.  
24 The light **46** could be located upon the exterior of the card holder **20** and would  
25 generally be powered by the electronic device **60** through the data transfer cable **50**  
26 connected to the adapter **34**. The light **46** would thus be electrically connected to the  
27 adapter **34** for being powered by the electronic device **60** or alternately electrically  
28 connected to a battery **40**.

1 **K. Data Transfer Cable.**

2 The data transfer cable **50** is adapted to electrically connect to the adapter **34** of the  
3 card holder **20** to transfer data from or to the smartcard **12** electrically connected to the  
4 contact pad **30** of the card holder **20**. The data transfer cable **50** generally includes a first  
5 end connector **51**, an elongated cord **53** extending therefrom, and a second end connector  
6 **55a**, **55b** extending from an opposing end of the cord **53**. It is appreciated that the data  
7 cable **50** may be easily disconnected from the card holder **20** and/or the electronic device  
8 **60**, such as in the case that the user forgets to unplug the cable **50** from the card holder **20**  
9 before beginning to walk away with the card holder **20**, wherein the card holder **20** would  
10 easily automatically disconnect from the cable **50**.

11  
12 The first end connector **51** may have various plugs and/or sockets to electrically  
13 connect to the adapter **34** of the card holder **20** in a manner that allows for data transfer or  
14 access. An example of a suitable plug is a USB connector; however it is appreciated that  
15 the first end connector **51** may be comprised of various structures all which mate with the  
16 adapter **34** and allow for a removable and secure connection to the adapter **34**.

17  
18 Likewise, the second end connector **55a**, **55b** may have various plugs and/or  
19 sockets to electrically connect to the electronic device **60** in a manner that allows for data  
20 transfer or access. An example of a suitable plug is a USB connector **55a**; however it is  
21 appreciated that the second end connector **55a**, **55b** may be comprised of various  
22 structures all which mate with the connector **61**, **63** of the electronic device **60**. For  
23 example, an auxiliary smartcard may comprise the second end connector **55b** to be  
24 received by a card reader **61** of the electronic device **60** and thus interface the cable **50**  
25 with the card reader **61** to communicate the data from the smartcard **12** within the card  
26 holder **20**. It is appreciated that the auxiliary smartcard **55b** would also include contact  
27 points for being read by the card reader **61**.

28

1 **L. *Electronic Device.***

2 The electronic device **60** may be any type of device that drives data transfer or  
3 access to and/or from the smartcard **12**. Suitable devices include personal computers, such  
4 as laptops, desktop computers, etc. Various other devices, such as PDAs, smart phones,  
5 etc. may be used as the electronic device **60**. The electronic device **60** generally includes  
6 at least one port **63** or card reader **61** to receive the second end connector **55a**, **55b** of the  
7 data transfer cable **50**.

8  
9 **M. *Operation of Preferred Embodiment.***

10 In use, when information is desired to transferred, read, or otherwise accessed from  
11 the smartcard **12** within the card holder **20**, the first end connector **51** of the data transfer  
12 cable **50** is connected to the adapter **34** and the second end connector **55a**, **55b** of the data  
13 transfer cable **50** is connected to or read by the electronic device **60**. Data may now be  
14 transferred between the smartcard **12** and the electronic device **60** without having to  
15 remove the smartcard **12** from the card holder **20**.

16  
17 When the owner of the smartcard **12** is finished transferring or accessing data, the  
18 first end connector **51** of the data transfer cable **50** is simply removed from the adapter **34**  
19 thus freeing the smartcard **12** from the data transfer cable **50** and preventing any further  
20 access to the smartcard **12** through the contact pad **13** of the smartcard **12**.

21  
22 Unless otherwise defined, all technical and scientific terms used herein have the  
23 same meaning as commonly understood by one of ordinary skill in the art to which this  
24 invention belongs. Although methods and materials similar to or equivalent to those  
25 described herein can be used in the practice or testing of the present invention, suitable  
26 methods and materials are described above. All publications, patent applications, patents,  
27 and other references mentioned herein are incorporated by reference in their entirety to the  
28 extent allowed by applicable law and regulations. In case of conflict, the present  
29 specification, including definitions, will control. The present invention may be embodied  
30 in other specific forms without departing from the spirit or essential attributes thereof, and

1 it is therefore desired that the present embodiment be considered in all respects as  
2 illustrative and not restrictive. Any headings utilized within the description are for  
3 convenience only and have no legal or limiting effect.  
4

1  
2  
3  
4  
5  
6  
7  
8  
9  
10  
11  
12  
13  
14  
15  
16  
17  
18  
19  
20  
21  
22  
23  
24  
25  
26  
27  
28  
29  
30  
**CLAIMS**

The invention claimed is:

1. A smartcard connector system, comprising:

a card holder having a card holding space;

a first signal transfer means connected to said card holder, wherein said first signal transfer means is in contact with said card holding space; and

a second signal transfer means connected to said card holder, wherein said second signal transfer means is in communicative contact with said first signal transfer means;

wherein said second signal transfer means is accessible from an exterior of said card holder and wherein said second signal transfer means is adapted to communicatively connect a smartcard received and held within said card holding space and in communicative contact with said first signal transfer means to an external data cable.

2. The smartcard connector system of Claim 1, wherein said card holder is comprised of a shielding card holder to shield wireless transmissions.

3. The smartcard connector system of Claim 1, wherein said card holder includes a rechargeable battery.

4. The smartcard connector system of Claim 1, wherein said card holder includes read/write memory.

5. The smartcard connector system of Claim 1, wherein said card holder includes a security unit.

1

2

3           6. The smartcard connector system of Claim 5, wherein said security unit is  
4 comprised of a biometric sensor.

5

6

7           7. The smartcard connector system of Claim 1, wherein said card holder includes a  
8 notification unit to alert a presence of an auxiliary radio frequency carrier.

9

10

11           8. The smartcard connector system of Claim 1, wherein said card holder includes  
12 an amplification unit to amplify a transmitted wireless signal from a held smartcard.

13

14

15           9. The smartcard connector system of Claim 1, including a display screen upon  
16 said card holder for displaying smartcard data.

17

18

19           10. The smartcard connector system of Claim 1, wherein said card holder includes  
20 a light.

21

22

23           11. A smartcard connector system, comprising:

24           a card holder having a card holding space;

25           a contact pad integral with said card holder and in communicative contact with said  
26 card holding space; and

27           an adapter integral with said card holder and in electrical contact with said contact  
28 pad, wherein said adapter is accessible from an exterior of said card holder;

1            wherein said adapter is for communicatively connecting a smartcard received and  
2 held within said card holding space and in electrical contact with said contact pad to an  
3 external data cable via connection of said data cable to said adapter.  
4  
5

6            12. The smartcard connector system of Claim 11, wherein said data cable includes  
7 a first end connector to connect to said adapter and a second end connector to connect to an  
8 electronic device.  
9  
10

11           13. The smartcard connector system of Claim 12, wherein said second end  
12 connector is comprised of a USB connector.  
13  
14

15           14. The smartcard connector system of Claim 12, wherein said second end  
16 connector is comprised of an auxiliary smartcard.  
17  
18

19           15. A smartcard connector system, comprising:  
20           a smartcard adapted to store data and having a first contact pad;  
21           a card holder having a card holding space, wherein said smartcard is removably  
22 positioned within said card holding space;  
23           a second contact pad connected to said card holder and in communicative contact  
24 with said card holding space and wherein said second contact pad is in electrical contact  
25 with said first contact pad;  
26           an adapter connected to said card holder and in electrical contact with said second  
27 contact pad, wherein said adapter is accessible from an exterior of said card holder; and  
28           a data cable having a first end connector, an elongated cord extending from said  
29 first end connector, and a second end connector extending from said elongated cord  
30 opposite said first end connector;

1            wherein said first end connector is removably connected to said adapter;  
2            wherein said second end connector is adapted to removably connect to an electronic  
3 device to access data from said smartcard within said card holding space of said card  
4 holder.

5

6

7            16. The smartcard connector system of Claim 15, wherein said first end connector  
8 is comprised of a USB connector.

9

10

11            17. The smartcard connector system of Claim 15, wherein said second end  
12 connector is comprised of a USB connector.

13

14

15            18. The smartcard connector system of Claim 15, wherein said second end  
16 connector is comprised of an auxiliary smartcard.

17

18

19            19. The smartcard connector system of Claim 18, wherein said auxiliary smartcard  
20 is fixedly connected to said elongated cord.

21

22

23            20. The smartcard connector system of Claim 15, wherein said electronic device is  
24 comprised of a computer.

25

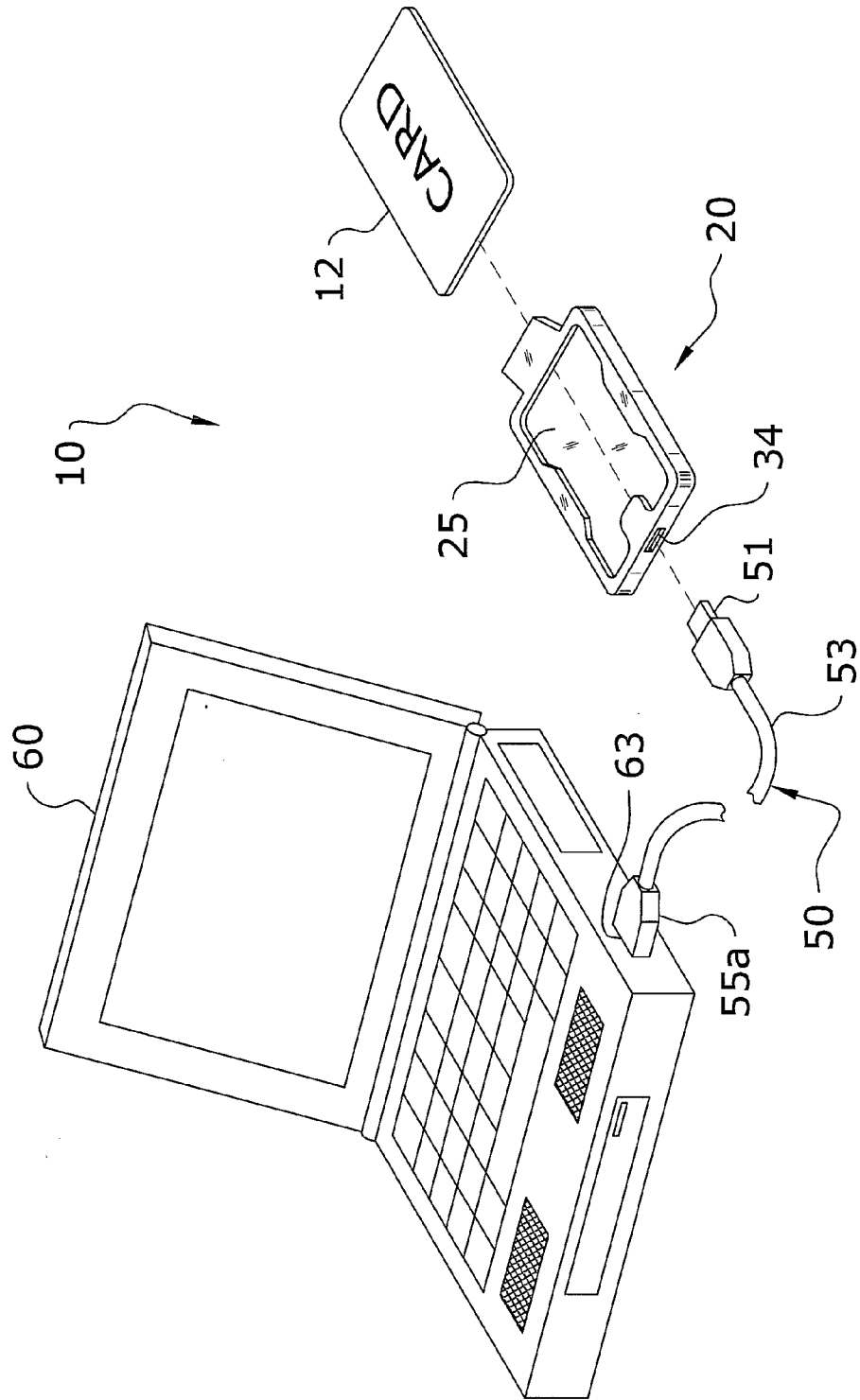

FIG. 1

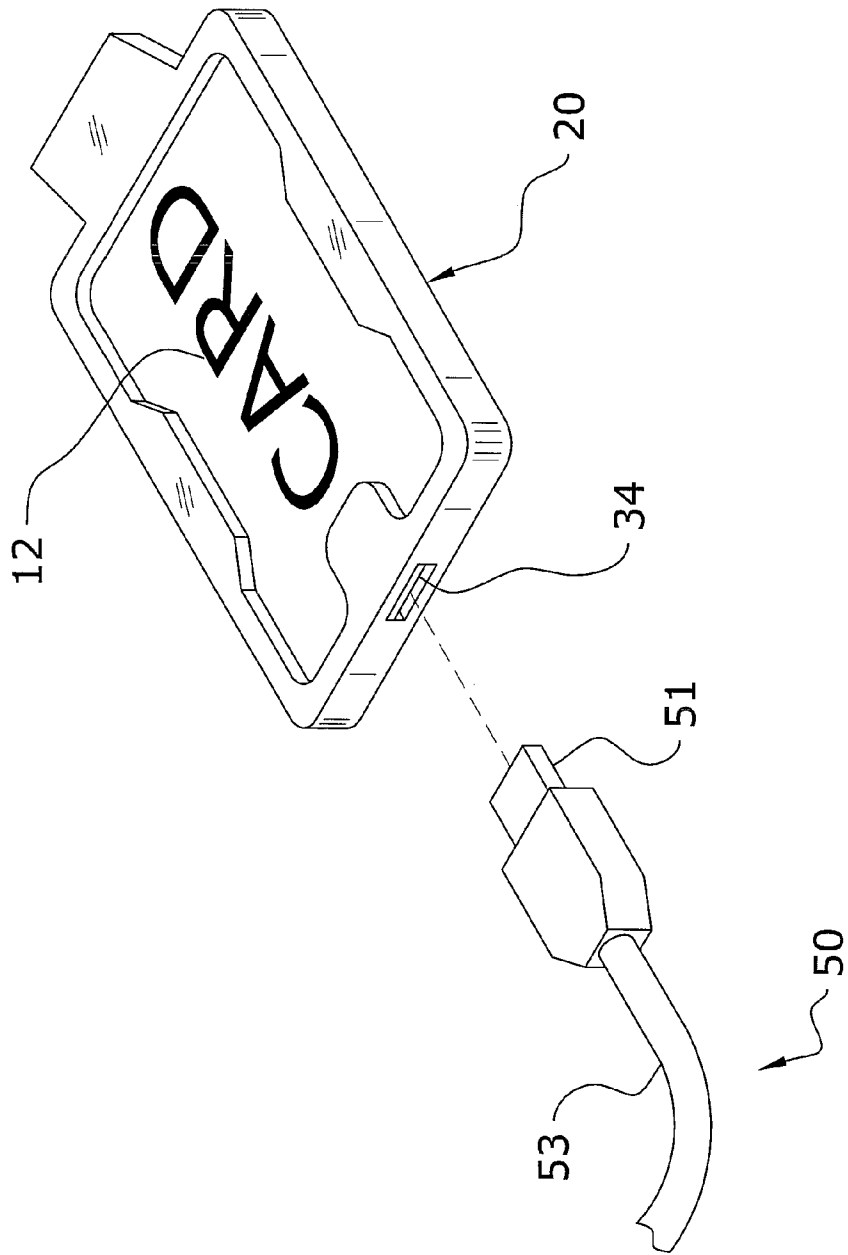

FIG. 2

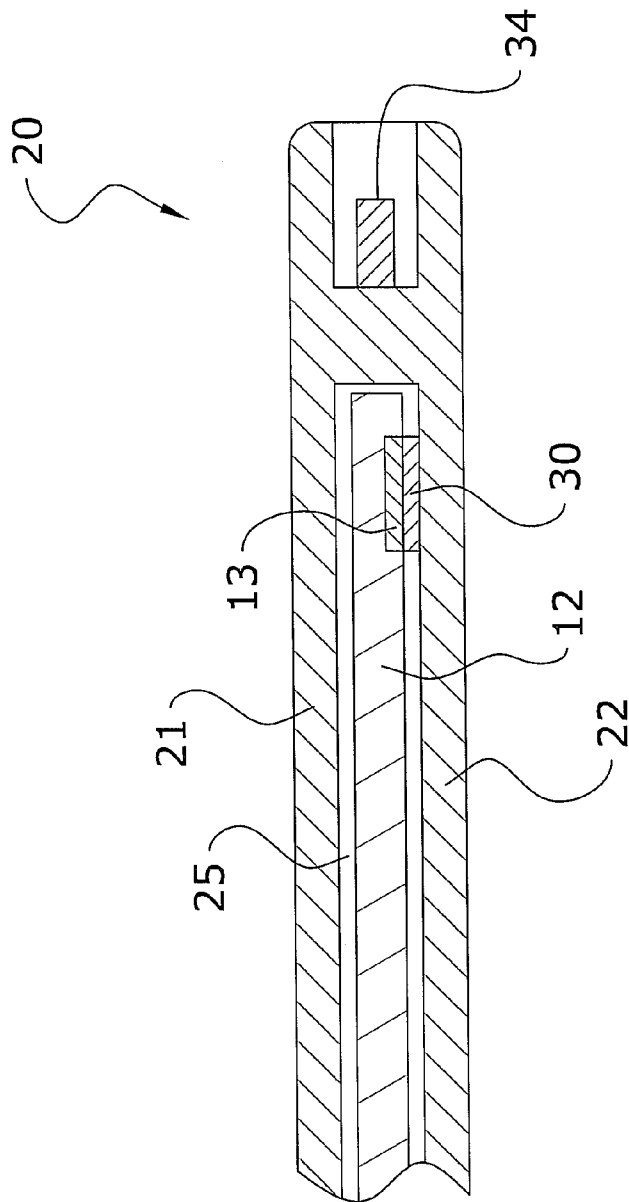

FIG. 3

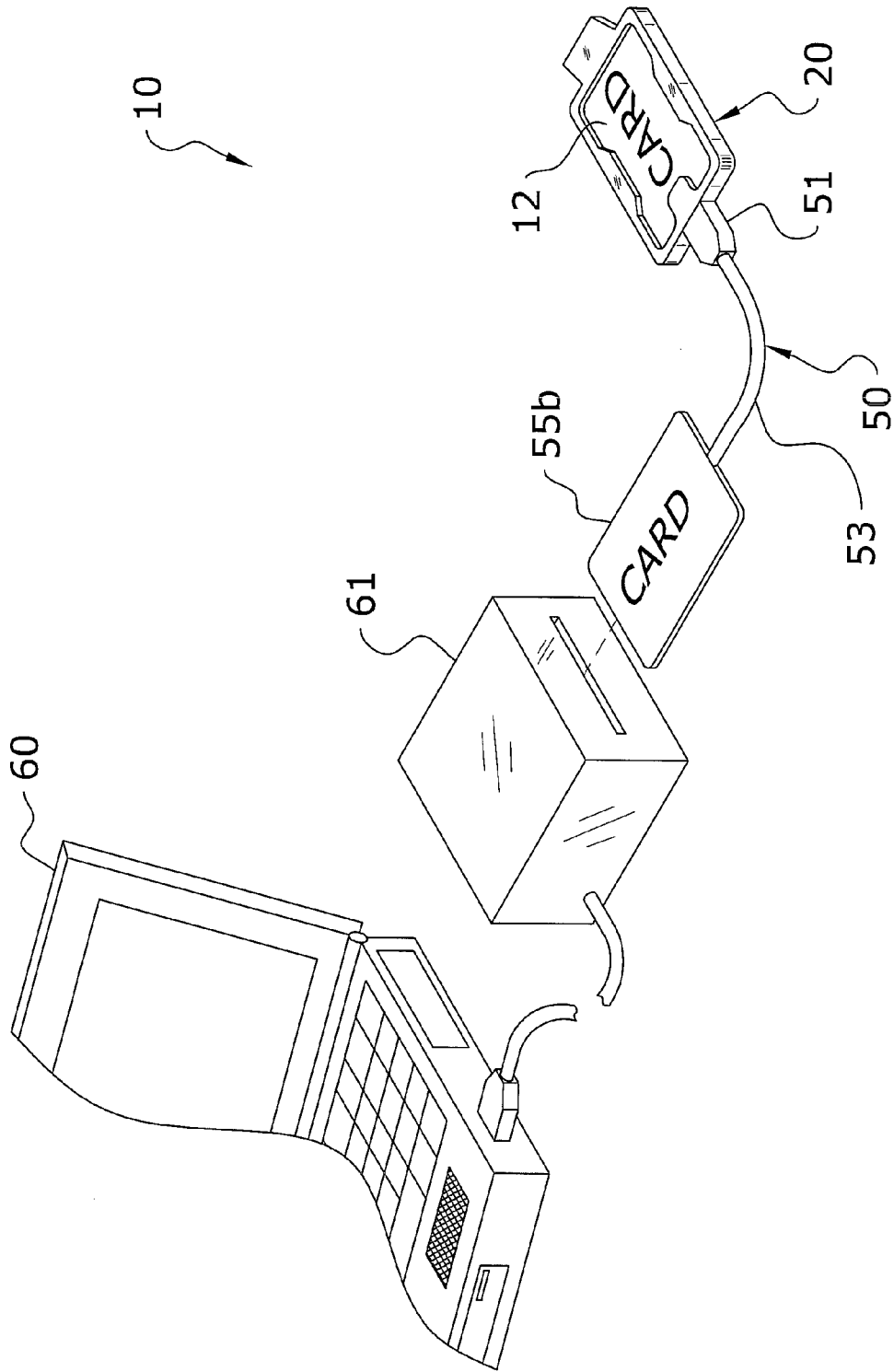

FIG. 4

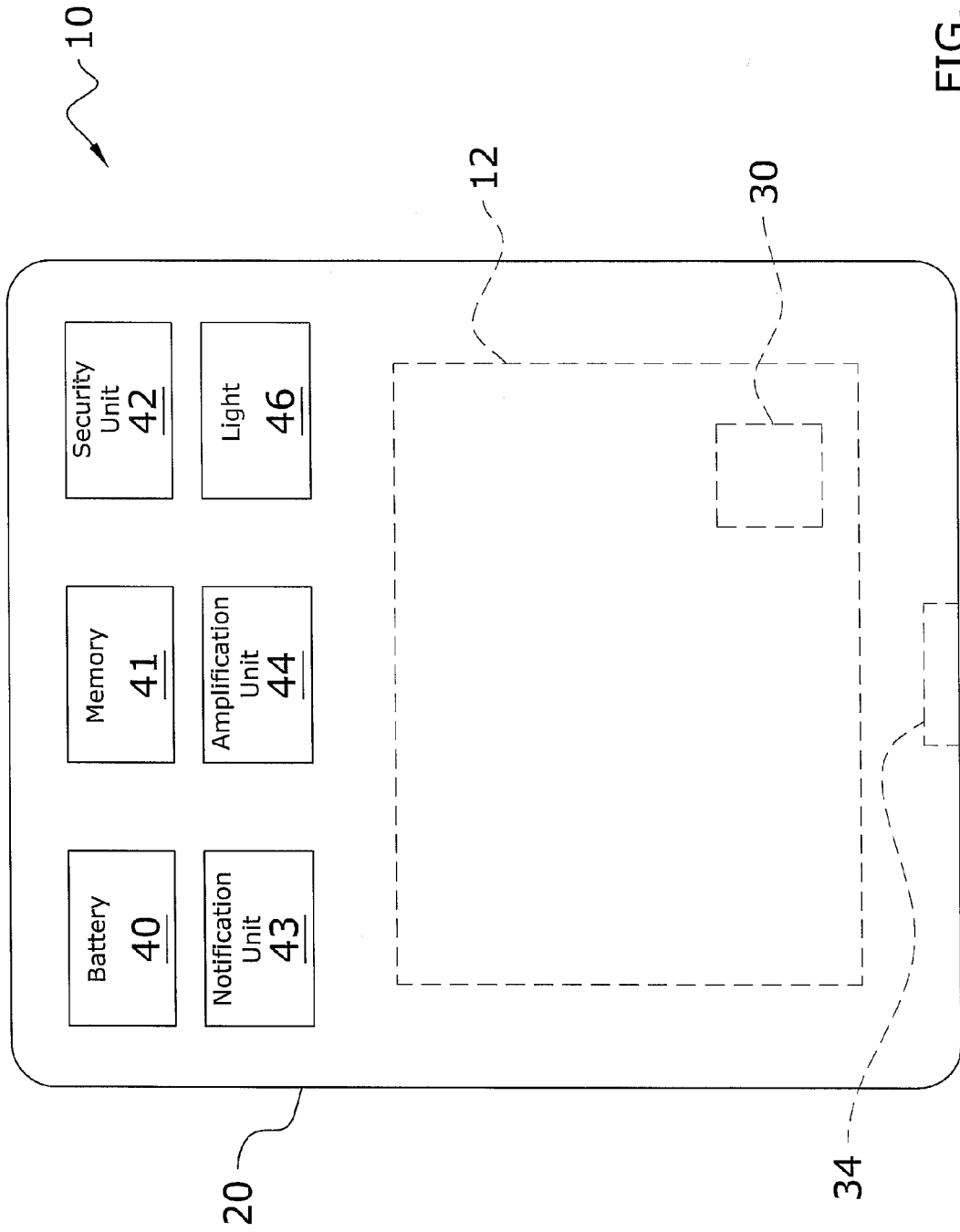

FIG. 5

## INTERNATIONAL SEARCH REPORT

International application No.  
**PCT/US2011/022312****A. CLASSIFICATION OF SUBJECT MATTER****H01R 12/70(2011.01)i, G06K 17/00(2006.01)i**

According to International Patent Classification (IPC) or to both national classification and IPC

**B. FIELDS SEARCHED**

Minimum documentation searched (classification system followed by classification symbols)

H01R 12/70; G06K 5/00; H01R 33/76; H01R 12/51; G06K 19/00; G11C 5/02

Documentation searched other than minimum documentation to the extent that such documents are included in the fields searched

Korean utility models and applications for utility models  
Japanese utility models and applications for utility models

Electronic data base consulted during the international search (name of data base and, where practicable, search terms used)

eKOMPASS(KIPO internal) &amp; Keywords:card, connector,holder, adapter, smart

**C. DOCUMENTS CONSIDERED TO BE RELEVANT**

Category*	Citation of document, with indication, where appropriate, of the relevant passages	Relevant to claim No.
X	US 06002605A A (IWASAKI; HIROSHI et al.) 14 December 1999 See column 12, line 59 - column 14, line 11 and figures 14-16.	1-20
A	KR 10-2009-0088057 A (TMSP CO., LTD. et al.) 19 August 2009 See paragraph [0016] - paragraph [0021] and figures 1-3.	1-20
A	KR 20-2009-0012142 U (KIM, YONG PIL) 01 December 2009 See paragraph [0034] - paragraph [0037] and figures 1-2.	1-20

 Further documents are listed in the continuation of Box C. See patent family annex.

\* Special categories of cited documents:

"A" document defining the general state of the art which is not considered to be of particular relevance

"E" earlier application or patent but published on or after the international filing date

"L" document which may throw doubts on priority claim(s) or which is cited to establish the publication date of citation or other special reason (as specified)

"O" document referring to an oral disclosure, use, exhibition or other means

"P" document published prior to the international filing date but later than the priority date claimed

"T" later document published after the international filing date or priority date and not in conflict with the application but cited to understand the principle or theory underlying the invention

"X" document of particular relevance; the claimed invention cannot be considered novel or cannot be considered to involve an inventive step when the document is taken alone

"Y" document of particular relevance; the claimed invention cannot be considered to involve an inventive step when the document is combined with one or more other such documents, such combination being obvious to a person skilled in the art

"&amp;" document member of the same patent family

Date of the actual completion of the international search

22 SEPTEMBER 2011 (22.09.2011)

Date of mailing of the international search report

**23 SEPTEMBER 2011 (23.09.2011)**

Name and mailing address of the ISA/KR

Korean Intellectual Property Office  
Government Complex-Daejeon, 189 Cheongsu-ro,  
Seo-gu, Daejeon 302-701, Republic of Korea

Facsimile No. 82-42-472-7140

Authorized officer

KIM, Sung Hee

Telephone No. 82-42-481-5889



**INTERNATIONAL SEARCH REPORT**

Information on patent family members

International application No.

**PCT/US2011/022312**

Patent document cited in search report	Publication date	Patent family member(s)	Publication date
US 06002605A A	14. 12. 1999	JP 10-302030 A KR 10-0279791 B1 US 06137710A A	13. 11. 1998 01. 02. 2001 24. 10. 2000
KR 10-2009-0088057 A	19. 08. 2009	None	
KR 20-2009-0012142 U	01. 12. 2009	None	