

C. RAHSSKOPFF.

Cutting Tools for Turning Lathes.

No. 134,313.

Patented Dec. 24, 1872.

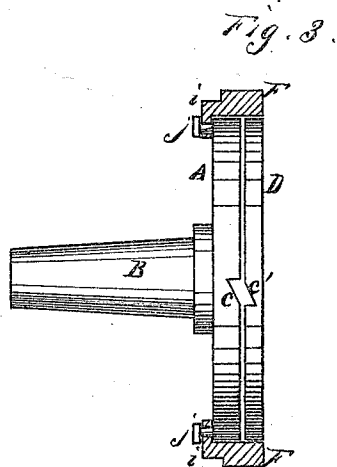
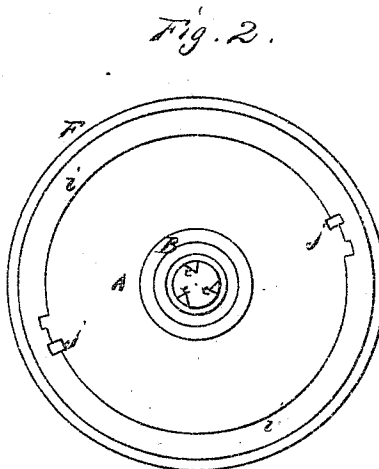
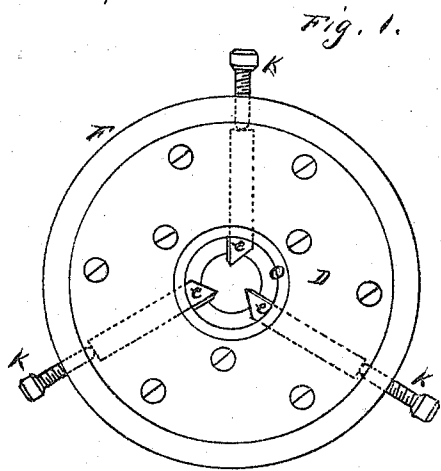

Witnesses

J. L. Broom
C. M. Richardson

Inventor

Charles Rahsskopff
per Dewey & Co.
Attys

UNITED STATES PATENT OFFICE.

CHARLES RAHSSKOPFF, OF SAN FRANCISCO, CALIFORNIA.

IMPROVEMENT IN CUTTING-TOOLS FOR TURNING-LATHES.

Specification forming part of Letters Patent No. 134,313, dated December 24, 1872.

To all whom it may concern:

Be it known that I, CHARLES RAHSSKOPFF, of San Francisco city and county, State of California, have invented an Improved Milling-Tool for Turning-Lathes; and I do hereby declare the following description and accompanying drawing are sufficient to enable any person skilled in the art or science to which it most nearly appertains to make and use my said invention or improvement without further invention or experiment.

My invention relates to an improved tool to be used on turning-lathes in place of the usual cutter or circular planer with a cutting-face for milling down or cutting a stem or rod of any required diameter from a piece of metal. My improvement consists of an arrangement by which detachable cutters or planers can be employed in place of the ordinary fixed or permanent ones. These cutters are so arranged that they can be adjusted to or from the center, as desired, in order to cut or trim a wider or narrower shoulder with a larger or smaller stem, as required.

In order to explain my invention so that others will be able to understand its construction and operation, reference is had to the accompanying drawing forming a part of this specification, in which—

Figure 1 is a front view; Fig. 2 is a back view; and Fig. 3 is an edge view of the inner pair of disks.

A represents a circular plate or disk having a hollow stem, B, projecting from its center upon one side. The hole which passes through the stem also passes through the center of the disk, and its edge on the face or outer side of the disk is beveled, as shown. Two or more angular grooves, *c c*, are made in the face of the circular plate radially from the center to the periphery. D is a circular plate or disk, which is also provided with a circular central opening, *o*, and which has radial grooves *c' c'* upon one side, so that when the two disks are secured together face to face by means of screws or other suitable device the radial grooves in the two plates or disks will be opposite each other. The grooves in the outer disk or plate D are also angular, as shown, so that the grooves in the two plates when thus brought together form a rhomboidal recess from the center to the circumference of

the united disks. *eee* are the cutters. These cutters are made to fit in the rhomboidal recesses above mentioned, and are therefore so constructed that a cross-section of either one at any point will give the figure of a rhomboid. The inner ends of these cutters are beveled so as to present as many cutting-points toward the center as there are cutters in the tool. A ring, F, which has an inward-projecting flange or shoulder, *i*, at one side, is then slipped over the outer rim of the two united disks until the projecting lugs or keys *j* on the back of the disk A pass through corresponding recesses in the flange *i*, so as to lock the ring upon the disks by turning the lugs upon the outside of the flange while the united disks remain inside against it. Set-screws *k k k* pass through this outer ring opposite each of the recesses *cc*, by which the cutters *eee* may be set to or from the center, as desired, according to the width of shoulder and diameter of stem it is desired to cut.

This tool is to be used in place of the usual reamer or planer used by metal-workers on a turning-lathe. The hollow stem B is to be secured in the face-plate of the turning-lathe, and the piece of metal to be turned is forced against the cutters *eee* through the central opening in the outer disk. The position of these cutters in the tool causes them to present a sharp cutting-edge to the shoulder and a sharp pointed edge for turning the stem. The cutters can be set to or from the center, as desired, by means of the screws *k k k*, and thus gage the diameter of the stem which it is desired to cut and the width of shoulder at the base of the stem. The stem as it is cut passes into the hollow stem of the tool.

When the cutters become dull or broken they can readily be removed by taking off the outer disk, and, after sharpening, be replaced again, thus providing a great advantage over the ordinary reamer or cutter, which is made with permanent teeth, which, when dulled or broken, require to be entirely remade by filing down the entire face.

Having thus described my invention, what I claim, and desire to secure by Letters Patent, is—

1. The disk A with its hollow stem B, and having its face provided with the radial grooves *c c*, in combination with the circular plate or

disk D with its central opening and corresponding radial grooves *c' c' c'*, substantially as and for the purpose above described.

2. In combination with the two disks A D with their central openings and corresponding radial grooves *e e e* and *c' c' c'*, the adjustable and removable cutters *e e e*, substantially as and for the purpose above described.

3. In combination with the disks A D with

their radial cutters *e e*, the ring F with its set-screws *k k k*, substantially as and for the purpose above described.

In witness whereof I hereunto set my hand and seal.

CHARLES RAHSSKOPFF. [L. S.]

Witnesses:

J. L. BOONE,

C. M. RICHARDSON.