



US 20130075302A1

(19) **United States**

(12) **Patent Application Publication**
Bucknell

(10) **Pub. No.: US 2013/0075302 A1**

(43) **Pub. Date: Mar. 28, 2013**

(54) **POP UP BROCHURE DISPLAY/PRODUCT DISPENSING UNIT**

Publication Classification

(75) Inventor: **Michael Bucknell**, North Narrabeen (AU)

(51) **Int. Cl.**
B65D 5/52 (2006.01)

(73) Assignee: **EZIADZ PTY LIMITED**, New South Wales (AU)

(52) **U.S. Cl.**
CPC **B65D 5/5206** (2013.01)
USPC **206/765**

(21) Appl. No.: **13/697,104**

(22) PCT Filed: **May 10, 2011**

(86) PCT No.: **PCT/AU2011/000534**

§ 371 (c)(1),
(2), (4) Date: **Dec. 7, 2012**

(57) **ABSTRACT**

A display unit for displaying and/or dispensing items, including a sleeve part and a container part, wherein the sleeve part is slidably mountable over the container part, and is slideable relative to the container part from a first pre-assembled condition to a second assembled condition, and wherein the second assembled condition, sections of the sleeve part are folded about fold lines to define at least one protruding foot portion, wherein the fold lines cause at least one surface of the protruding foot portion to form a compound curved, non-planar surface which imparts rigidity to the unit when in the second assembled condition.

(30) **Foreign Application Priority Data**

May 11, 2010 (AU) 2010901980

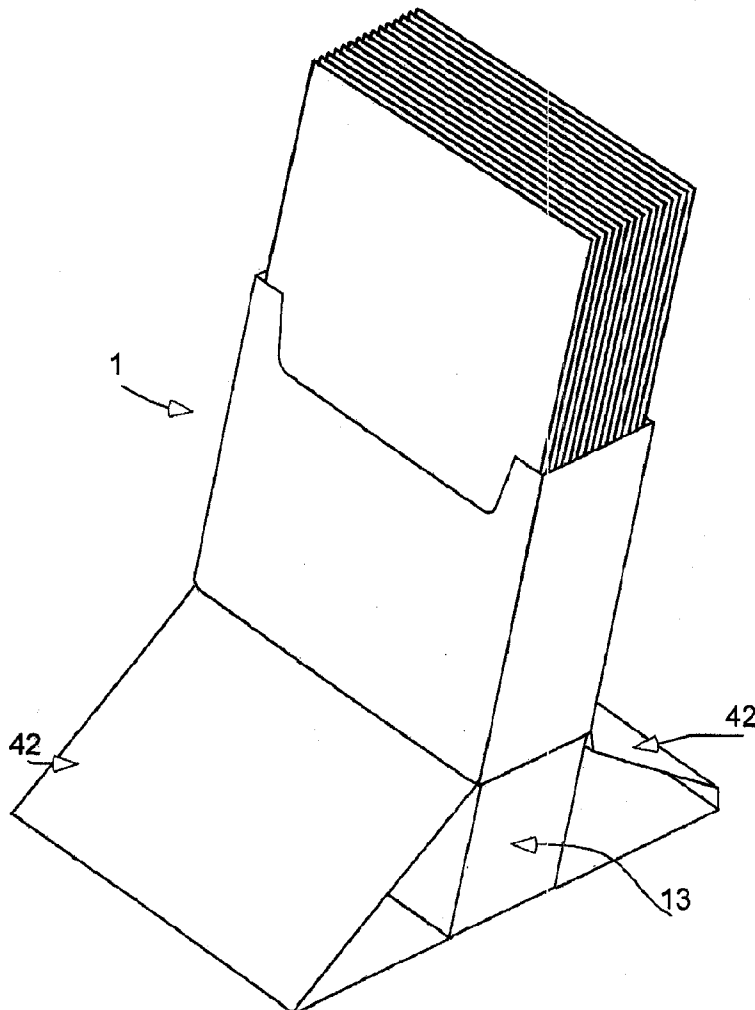



Figure 1

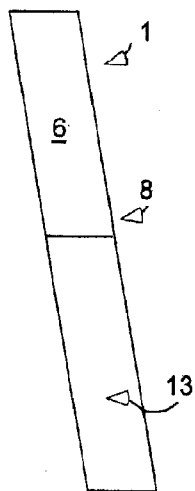

Figure 2

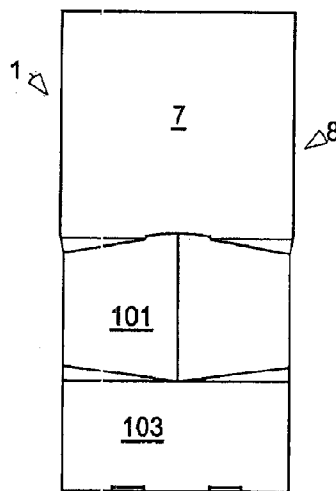

Figure 3

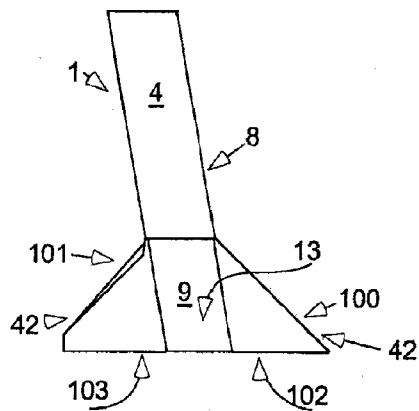

Figure 4

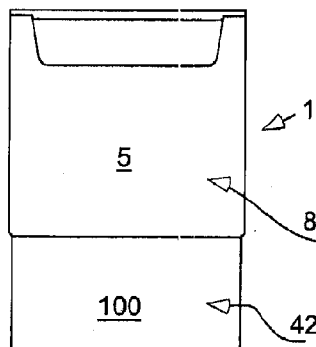

Figure 5

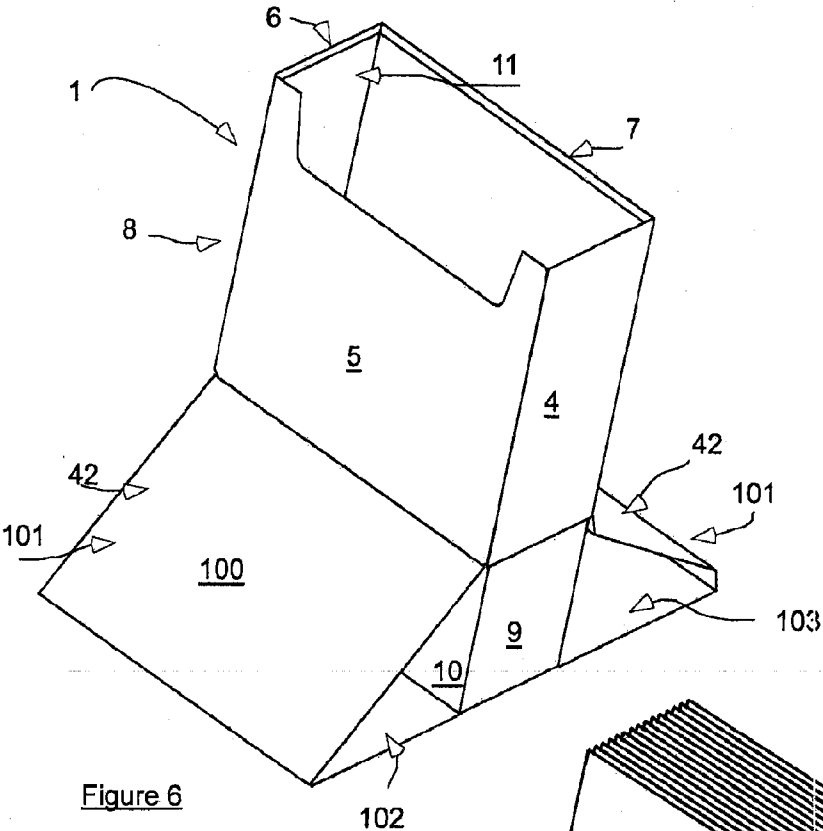

Figure 6

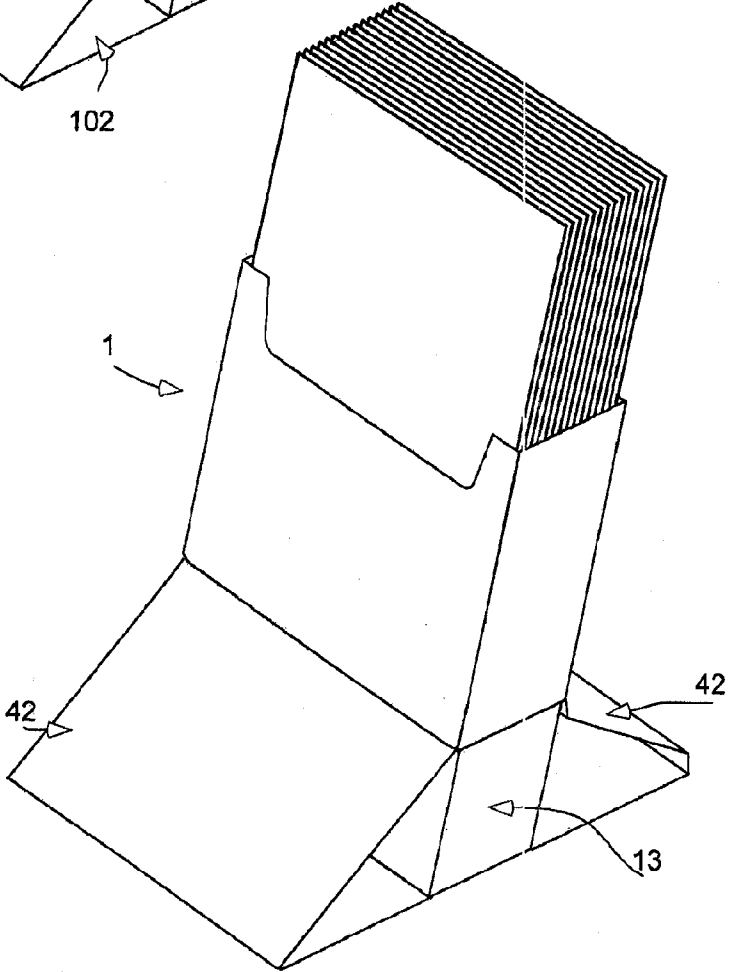

Figure 7

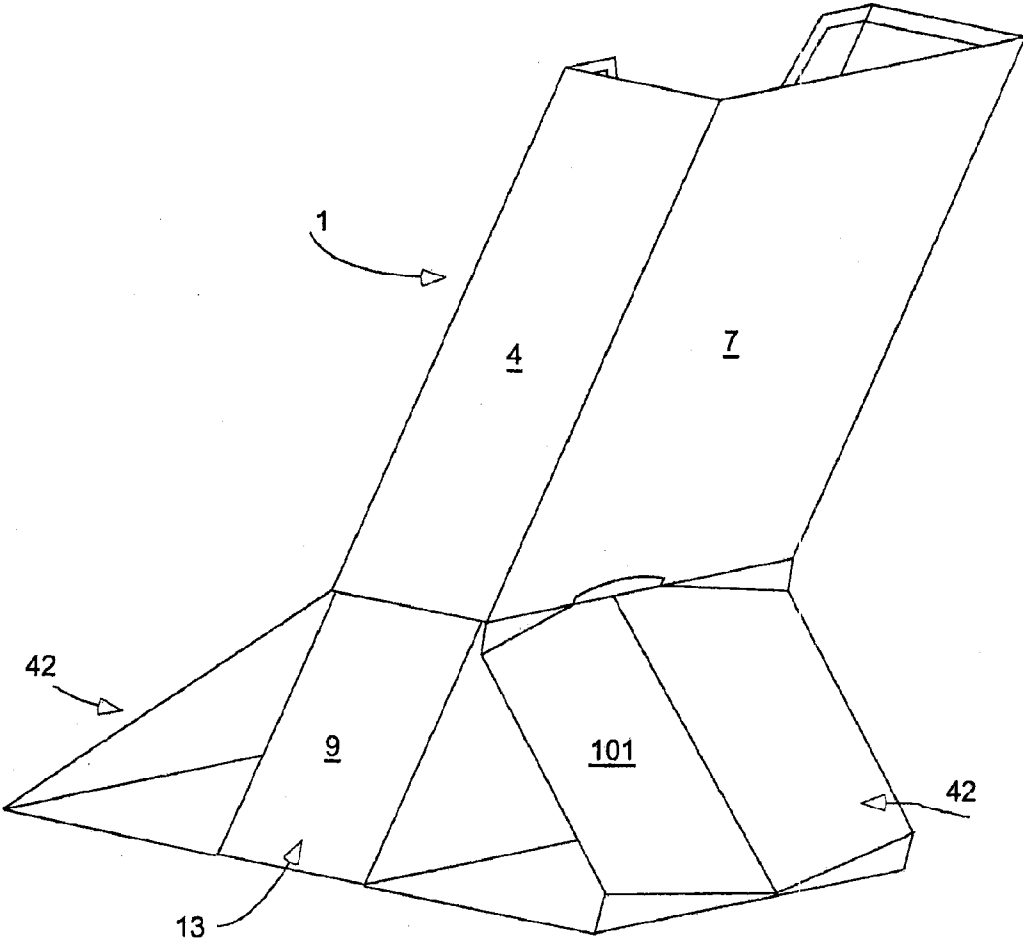

Figure 8

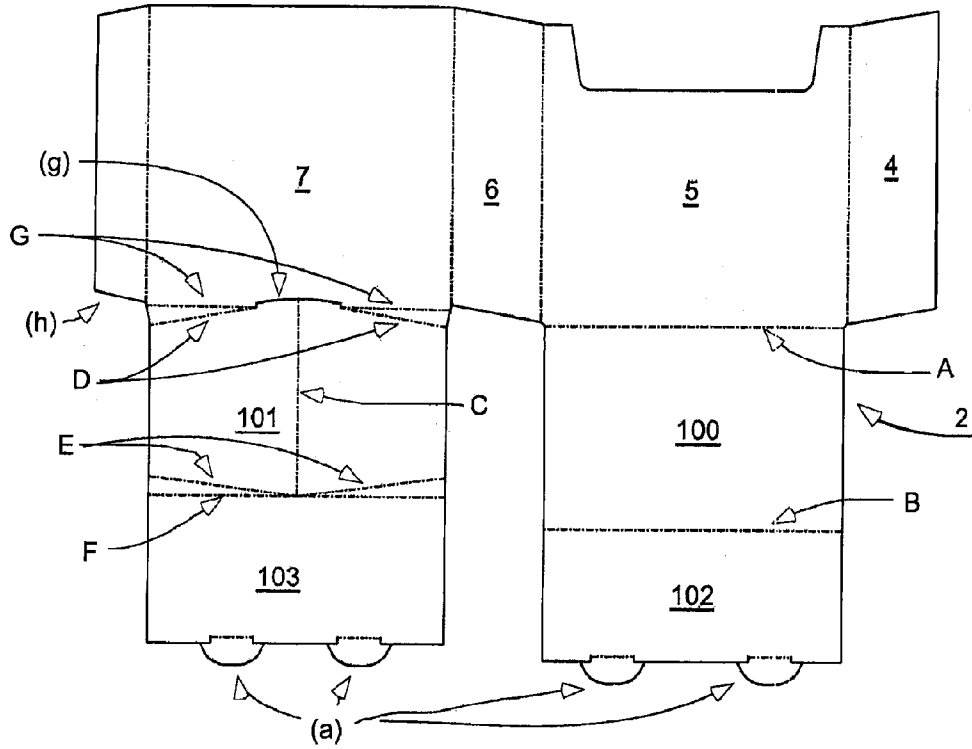

Figure 9

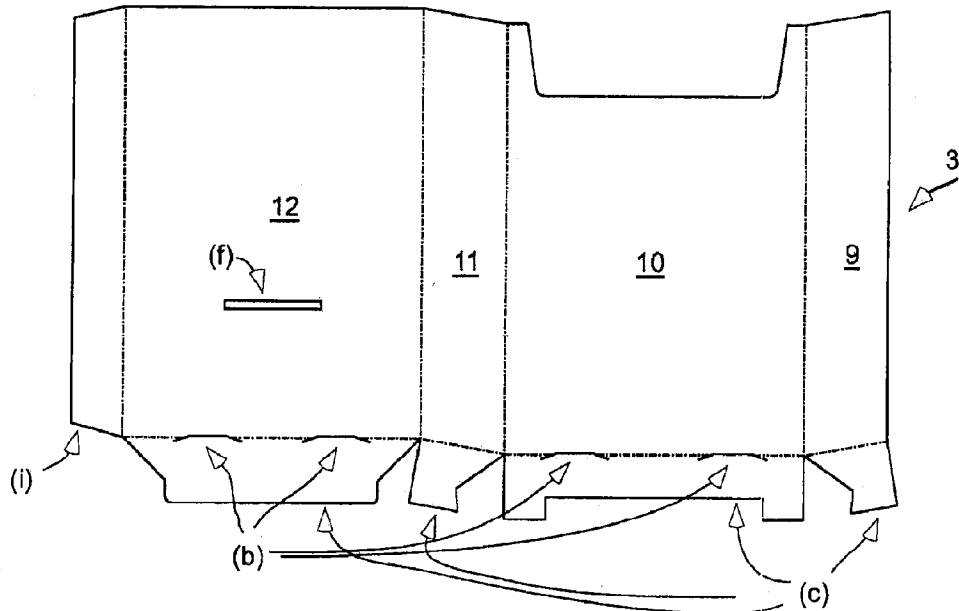

Figure 10

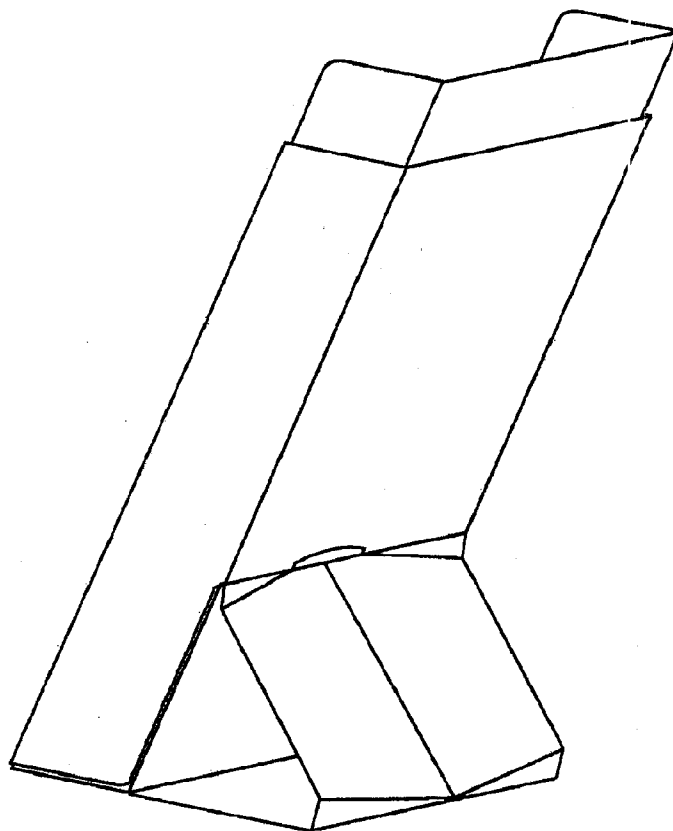

Figure 11

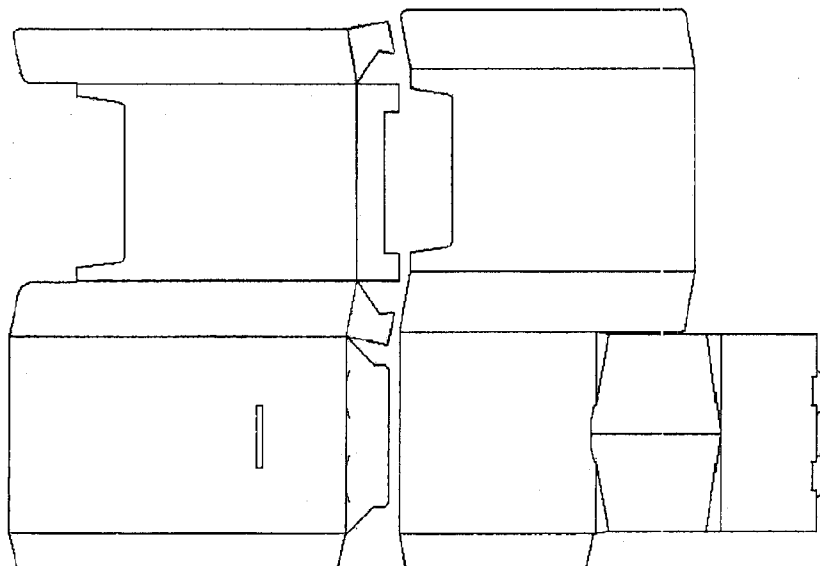

Figure 12a

Figure 12b

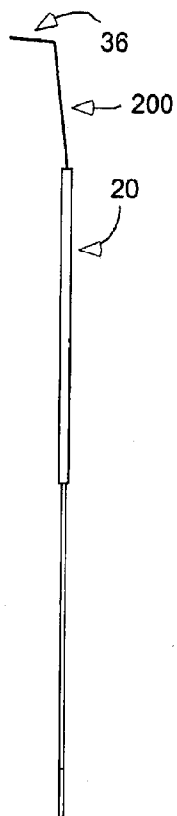

Figure 13

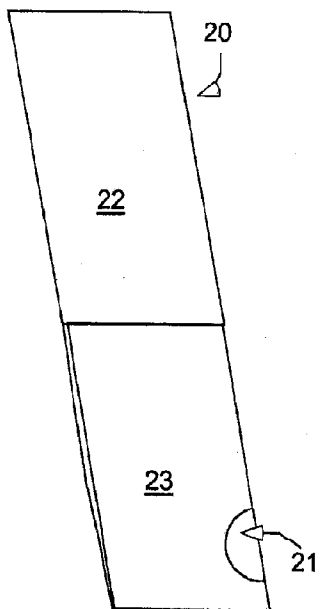

Figure 14

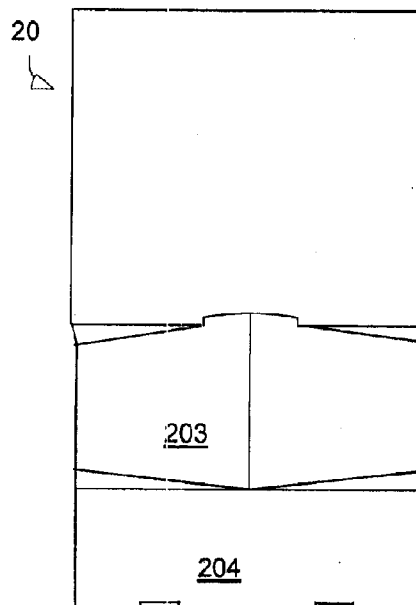

Figure 15

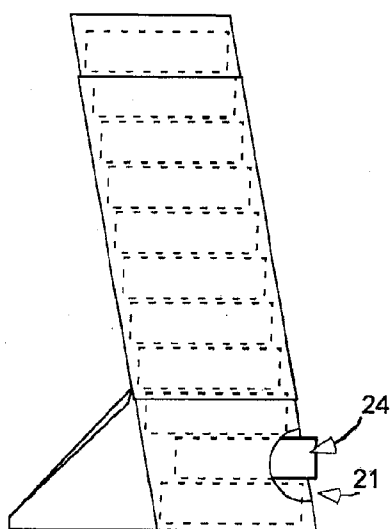

Figure 16

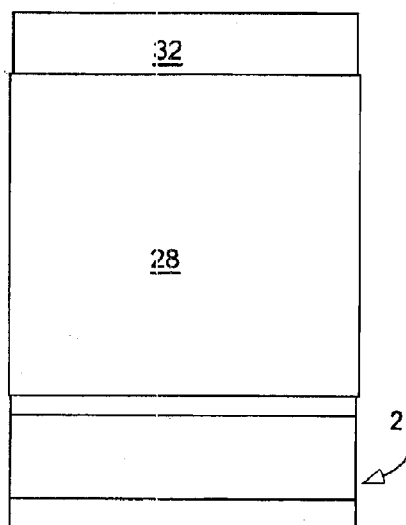

Figure 17

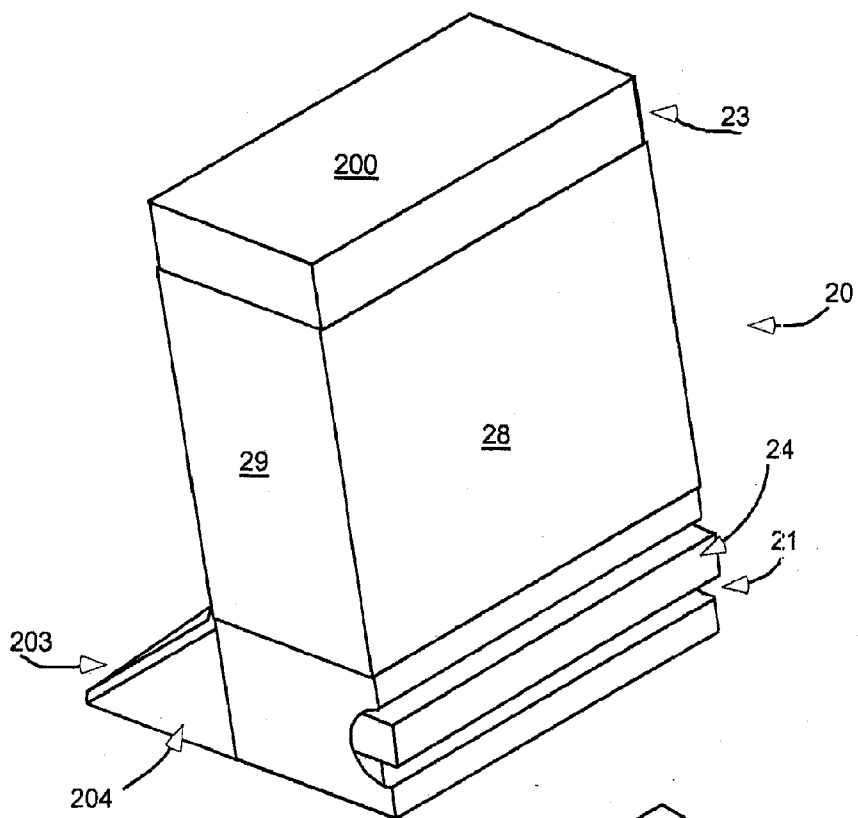

Figure 18

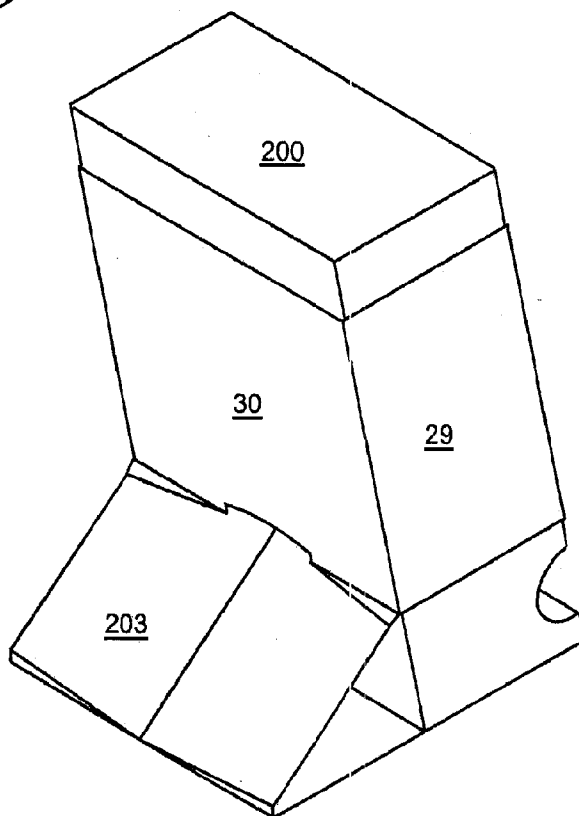

Figure 19

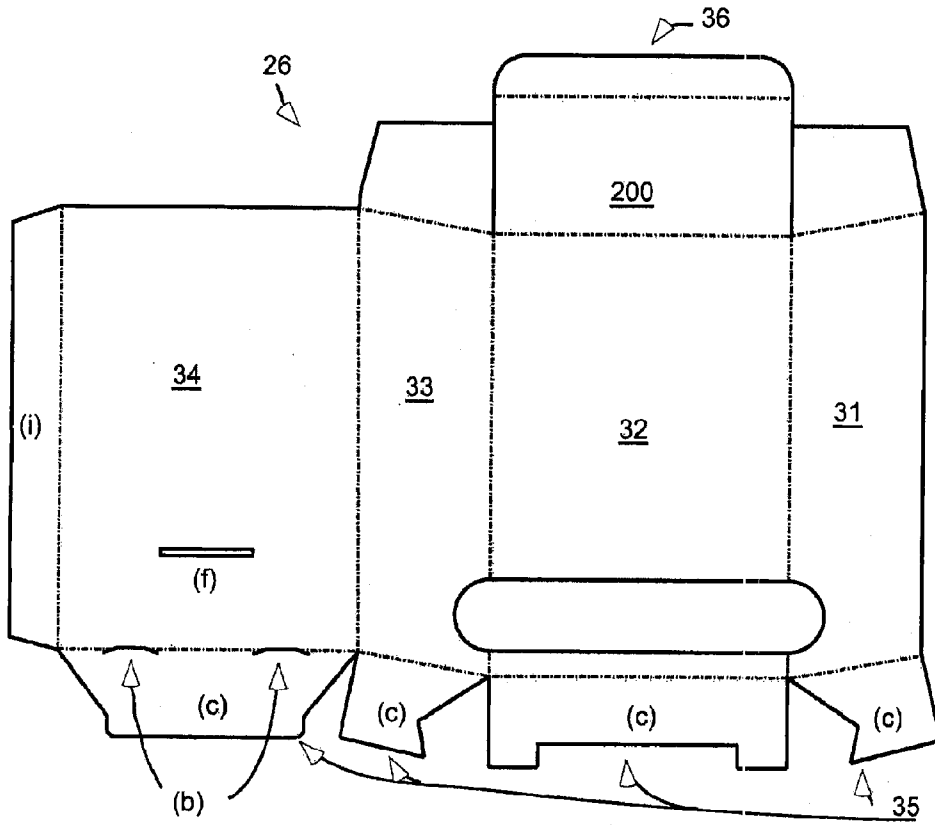

Figure 20

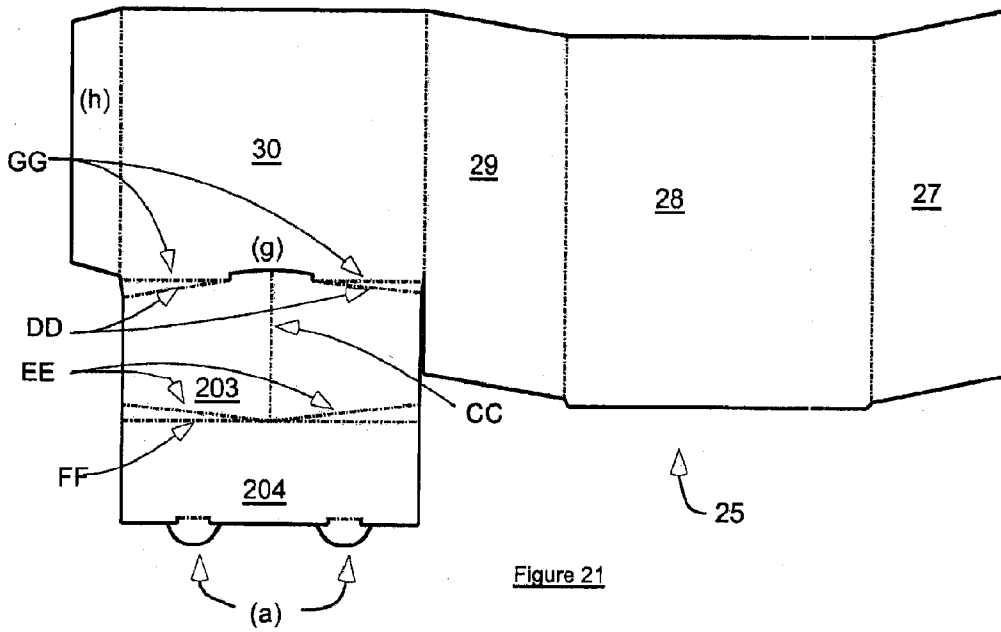

Figure 21

POP UP BROCHURE DISPLAY/PRODUCT DISPENSING UNIT

PRIORITY CLAIM

[0001] This patent application is a U.S. National Phase of International Patent Application No. PCT/AU2011/000534, filed 10 May 2011, which claims priority to Australian Patent Application No. 2010901980, filed 11 May 2010, the disclosures of which are incorporated herein by reference in their entirety.

FIELD

[0002] Disclosed embodiments relate to improvements in user-assembled ('pop-up'), stand-alone containers that are constructed of cardboard or similar materials that may be pre-packed for shipping and subsequently used to display brochures or to dispense products at point of purchase.

BACKGROUND

[0003] There are currently a number of brochure holders and product dispensers made of plastic and similar materials on the market. There are also a number of variations of cardboard pop-up brochure display packs available, as well as cardboard pop-up gravity-fed dispensing packs. These will be jointly referred to generally as "display units".

[0004] One such pop-up display unit is disclosed in granted Australian patent number AU 780843 and which has been commercialised under the trade mark EZIPOP®. This unit features front and rear angled struts and displays the brochures (or other products) in a vertical orientation. However, a disadvantage of this design is that thin leaflets tend to curl over at the top edge of unit and fan out, resulting in an untidy and non-aesthetically pleasing display.

[0005] To address this problem, a unit which slants backwards has been designed to cause the leaflets displayed in the unit to thereby lean backwards. However, tests conducted in a humid environment have shown that a slanted cardboard pop-up brochure display unit similar to the EZIPOP® design for example, gradually leans back further and further over time, with the rear angled strut distorting sufficiently to eventually cause the unit to collapse or the front angled strut to lift off the counter or table surface.

[0006] There is therefore a need for an improved pop-up display unit which ameliorates the above-mentioned problem.

SUMMARY

[0007] Disclosed embodiments provide a strut portion which includes a compound curved surface to impart stiffness and rigidity to the display unit.

[0008] A first disclosed embodiment provides a display unit for displaying and/or dispensing items, including a sleeve part and a container part, wherein the sleeve part is slidably mountable over the container part, and is slideable relative to the container part from a first pre-assembled condition to a second assembled condition, and wherein to form the second assembled condition, sections of the sleeve part are folded about fold lines to define at least one protruding foot portion, wherein the fold lines cause at least one surface of the protruding foot portion to form a compound curved, non-planar surface which imparts rigidity to the unit when in the second assembled condition.

[0009] In at least one disclosed embodiment, the fold lines include at least one substantially vertical fold line extending about mid-way between side edges of the sleeve part, and four angled fold lines extending from the vertical fold line to the side edges.

[0010] In the second assembled condition, the display unit includes a supporting surface which is angled rearwards from the vertical for displaying the items in a non-vertical orientation. Optionally, the supporting surface is angled rearward by between 1° and 20° from the vertical, and ideally about 10°.

BRIEF DESCRIPTION OF THE DRAWINGS

[0011] Reference will now be made to the accompanying drawings which disclose various embodiments and explain the unique configurations and relative dimensions that form the basis of the invention.

[0012] FIG. 1 is an edge (side) elevation of an assembled display unit according to one disclosed embodiment in a flattened state;

[0013] FIG. 2 is a side elevation of the display unit of FIG. 1 in a partially assembled condition;

[0014] FIG. 3 is a rear elevation of the partially assembled display unit of FIG. 2;

[0015] FIG. 4 is a side elevation of the display unit of FIG. 1, in a fully assembled condition;

[0016] FIG. 5 is a front elevation of the fully assembled display unit of FIG. 4;

[0017] FIG. 6 is a perspective view from the front of the assembled display unit of FIG. 4;

[0018] FIG. 7 is a perspective view of the assembled display unit of FIG. 6 when filled with brochures;

[0019] FIG. 8 is a perspective view from the rear of the assembled display unit of FIG. 4;

[0020] FIG. 9 is an elevation of an outer sleeve blank for the display unit of FIG. 1 shown unfolded;

[0021] FIG. 10 is an elevation of a bottom inner base blank for the display unit of FIG. 1 shown unfolded;

[0022] FIG. 11 is a perspective view from the rear of a display unit according to a second disclosed embodiment;

[0023] FIG. 12a is an elevation of an outer sleeve blank for the display unit of FIG. 11 shown unfolded;

[0024] FIG. 12b is an elevation of a bottom inner base blank for the display unit of FIG. 11 shown unfolded;

[0025] FIG. 13 is an edge (side) elevation of an assembled display unit according to a third disclosed embodiment in a flattened state;

[0026] FIG. 14 is a side elevation of the display unit of FIG. 13 in a partially assembled condition;

[0027] FIG. 15 is a rear elevation of the partially assembled display unit of FIG. 14;

[0028] FIG. 16 is a side elevation of the display unit of FIG. 13 in a fully assembled condition when filled with products;

[0029] FIG. 17 is a front elevation of the fully assembled display unit of FIG. 13;

[0030] FIG. 18 is a perspective view from the front of the fully assembled display unit of FIG. 13 when filled with products;

[0031] FIG. 19 is a perspective view from the rear of the fully assembled display unit of FIG. 13;

[0032] FIG. 20 is an elevation of an inner sleeve blank for the display unit of FIG. 13 shown unfolded; and

[0033] FIG. 21 is an elevation of an outer sleeve blank for the display unit of FIG. 13 shown unfolded.

DETAILED DESCRIPTION OF DISCLOSED EMBODIMENTS

[0034] According to at least one disclosed embodiment of the display unit, the sleeve part is formed from a first shaped blank of card or other flat material and by folding about four substantially parallel first fold lines is movable between a first condition in which the sleeve part defines a sleeve of rectangular cross section in a plane perpendicular to the first fold lines and a second condition in which the sleeve part lies at least approximately flat; the container part is formed from a second shaped blank of card or other flat material and by folding about four substantially parallel second fold lines is movable between a first condition in which the container part at least partially defines a container of rectangular cross section in a plane perpendicular to the second fold lines and a second condition in which the sleeve part lies at least approximately flat; the container part is slideable within the sleeve part in a sliding direction parallel to the first and second fold lines, at least in the first condition of the sleeve part and the first condition of the container part; and the sleeve part and the container part are secured to each other by connecting means so that when the container part is slid by a user in the sliding direction within the sleeve part, sections of the sleeve part are folded about the fold lines in the sleeve part and the sections define a least one protruding foot portion of the sleeve part.

[0035] Disclosed embodiments provide a pop-up brochure display or product dispenser that is stable, strong and economical to produce and distribute by providing a construction configuration based on two blanks, that, minimises wastage and suits automatic carton gluing machines, eliminating hand gluing; providing improvements to mechanisms of erection currently used in these forms of displays; and providing a different rear strut mechanism as part of the protruding foot that by virtue of its compound curves, adds strength that allows the angling back of the display unit without compromising its integrity and appearance; and allows the units to be transported or stored in a flattened state, then easily erected at the intended point of display or use.

[0036] The rear strut mechanism is very strong and as more pressure is applied towards the rear of the brochure display or product dispensing unit, the rear angled strut stiffens and becomes more resistant to any movement. Additionally, the front angled strut (when used) stays flat against the counter or table surface.

[0037] Therefore, the appearance of the display unit is not compromised even in humid environments, and the angled back design adds a new dimension and visual appeal to the unit at point of purchase. Optionally, the front angled strut can be eliminated and the blank modified to present a full flat front and sides for enhanced visual presentation.

[0038] The configuration allows the use of available machinery to manufacture angled back pop-up units as two components, rather than die cutting a single blank requiring further manufacture.

[0039] One of the components, an outer sleeve, is conventionally die cut and creased. It is then glued in-line to form a sleeve with tabbed extensions. The other component, an inner base/pocket, is also conventionally die cut and creased then glued in-line to form a box with e.g. a crash-lock bottom; a folded bottom; a snap-lock bottom, or optionally any other type of bottom. Both components may be shipped flat so they occupy a minimum of space in transport and/or storage.

[0040] Final assembly simply involves slipping the outer sleeve over the base and inserting locking tabs into corre-

sponding slots. This operation may be undertaken by unskilled labour. It can be done at the manufacture stage, so that the entire unit is shipped in a form ready to simply 'pop up' on site, or the base and sleeve may be shipped and stored separately and only brought together when they are to be erected for use.

[0041] If the units are to be filled with brochures or product, the pack can be snapped open, the crash-lock bottom, snap-lock, or folding bottom, holding the unit in the erected position. If the units are to be filled later or shipped to another location for filling, they can be left unopened so they lie flat for efficient transport.

[0042] Once assembled at point of dispensing, location tabs in the back and or front of the outer sleeve engage with corresponding slot/s in the inner base/pocket, providing extensions, which give stability and prevent the units from collapsing when displayed.

[0043] Due to the angles incorporated in the die-cut and creased inner and outer parts, once assembled and erected, the display unit may have a lean back of between 1° to 20°, ideally 10°, with the front and rear strut parts being the correct size and shape to form front and rear angled supports to the unit.

[0044] Enhancements can be made to accommodate variations to the brochure or product that is to be contained in the display unit. For example, the display unit may feature a window cut out of the front to display a picture on the brochure or to view the product held within; or it might have a 'cut-down' front to reveal more of a brochure or it could have an integral header or side extension. In another disclosed embodiment, the unit might be required to dispense two or more different brochures or products side by side. In this case, dividers may be used to separate the brochures or products. In another variation, the front angled strut can be eliminated and the brochure unit blank modified to present a full flat front and sides for enhanced visual presentation. Eliminating the front angled strut in the product dispenser, gives a lower centre of gravity and a lower dispensing slot.

[0045] A pop-up display unit 1 according to a first disclosed embodiment will now be described. FIGS. 1 to 8 show various views of the unit 1, from its initial partially assembled but collapsed flat state (shown in FIG. 1) to its partially assembled state (shown in FIGS. 2 and 3) to its fully assembled state (shown in FIGS. 4 to 8). It can be seen from FIG. 1 that the collapsed flat unit 1 takes up very little space. FIG. 2 shows the unit 1, in a partly assembled condition, side-on, and FIG. 3 shows the partly assembled unit 1 from the rear. FIG. 4 is a side view of the fully assembled unit 1 and FIG. 5 shows the fully assembled unit from the front. FIG. 7 shows the fully assembled unit filled with brochures.

[0046] The unit 1 has two parts, namely an outer sleeve 8 formed from blank 2 as shown in FIG. 9 and an inner base 13 formed from blank 3 as shown in FIG. 10, which are both made from flat cardboard. It should, however, be understood that other flat, foldable materials may be used and are within the scope of the invention. When outer sleeve blank 2 has been formed, glue flap (h) is glued to section 4 so that upon assembly of the unit 1, sections 4, 5, 6 and 7 form sides of outer sleeve 8. Locking tabs (a) insert during initial assembly into slots (b) of inner base blank 3, shown in FIG. 10. Also shown in FIG. 9 is location tab (g) which, when the unit 1 is erected, locates in slot (f) in the inner base blank 3.

[0047] FIG. 10 shows the inner base blank 3, with a glue flap (i) which is glued, when the blank 4 has been formed, to

section 9 so that on assembly of the unit 1, sections 9, 10, 11 and 12 form sides of inner base 13. When blanks 2 and 3 have been formed and flaps (h) and (i) glued in their respective positions, they are assembled together by sliding the inner base 3 inside outer sleeve 2 and tabs (a) located in slots (b). At this stage, the sleeve 8 and the inner base 9 can lie flat as shown in FIG. 1, for convenient transport.

[0048] When the unit 1 is to be readied for use, outer edges of the flattened assembly are pushed together, so that the inner base 13 assumes an open-topped box shape, and the sleeve 8 surrounds it. At this stage, shown in FIGS. 2 and 3, the snap-lock bottom is formed by manually folding flaps (c) 1-2-3, as known in the art.

[0049] To finally assemble the unit 1, the outer sleeve unit 8 is pushed downwards around the sleeve 13, until tab (g) locates in slot (f). The downwards force causes the sleeve unit 8 to fold along fold lines shown by broken lines in FIG. 9 and marked "A" to "G". This causes strut sections 100 and 101 and bases 102 and 103 to be pushed outwardly to form protruding feet or extensions 42 supporting the unit 1 upright on a surface. The particular fold lines in the rear strut 100, as shown in FIGS. 3 and 9, create a compound curve shape rather than a planar surface, thereby providing strength to the strut 101. The unit 1 then has the completed form shown in FIGS. 4 to 8 and is ready for use.

[0050] As best seen in FIGS. 3 and 9, the fold lines in the back strut 101 that create the compound curve include a medial fold line C running substantially parallel to the sides of the sleeve unit 8, two angled fold lines D extending from the edge of the flap (g) to the side edges of sleeve unit 8, a base edge fold line F running substantially perpendicular to the sides of the sleeve unit 8, two further angled fold lines E extending from the junction of the medial C and base edge F fold lines to the side edges of the sleeve unit 8, and finally two upper fold lines G extending from the flap (g) substantially horizontally to the side edges of the sleeve unit 2.

[0051] As best seen in FIGS. 2, 4 and 8, when in the assembled state the unit 1 is slanted backwards from the vertical. Optionally, the slant angle is within a range of about 1° to 20°, and ideally about 10°. However, other angles may be used depending upon the needs and desire of the user, including vertical. FIG. 11 discloses an embodiment of a display unit. While the general construction is similar to the previously disclosed embodiment, in this disclosed embodiment there is no front strut, and the inner blank has been extended in height to add support to brochures. FIGS. 12a and 12b show the blanks for the inner base and sleeve for the alternative design.

[0052] A pop-up display unit 20 according to a third disclosed embodiment will now be described as shown in FIGS. 13 to 21. This disclosed embodiment may be used as a gravity-fed dispensing unit for products, such as for example tablet packets, rather than brochures as was described in first disclosed embodiment.

[0053] The same general construction is used to the display unit 1, being made from two cardboard (or other material) blanks 25 and 26 as shown in FIGS. 20 and 21, one of which forms an outer sleeve 22 and the other of which forms an inner base 23. Also similarly, the display unit 20 can be laid flat for storage and transport as shown in FIG. 13, and then easily assembled when required.

[0054] The inner base 23 is in effect a closed-top box for enhanced usability and security for the contained products. However, the inner base 23 could equally be open topped as in

the first and second disclosed embodiments if desired. The products fall under gravity towards, and can be removed from, a side slot 21 in the assembled unit 20.

[0055] FIGS. 13 to 21 show various views of the display unit 20, from its initially-assembled and collapsed flat state (shown in FIG. 13) to fully assembled (FIGS. 16 to 19). As can be seen in FIG. 13, the collapsed flat unit 20 takes up little space. FIG. 14 shows the unit 20 side-on in a partially-assembled stage and FIG. 15 shows the unit 20 in the same state, from the rear. FIGS. 16 and 17 show the popped-up (i.e. fully assembled) unit 20 with dispensing slot 21. FIGS. 18 and 19 are perspective views of the display unit 20, with FIG. 18 showing a box of product 24 emerging from the dispensing slot 21.

[0056] FIG. 21 shows the outer sleeve blank 25 from which the outer sleeve 22 is formed. FIG. 20 shows the inner base blank 26 from which the inner base 23 is formed. Slotted locking tabs (a) are shown on blank 25, and these insert, during initial assembly of the unit 20, into slots (b) in blank 26. Also shown in FIG. 20 is location tab (g) which, when the unit 20 is erected for use, locates in slot (f) in inner base 23—this slot can be seen in blank 26.

[0057] Outer sleeve blank 25 has a glue flap (h) which when the blank 25 has been formed is line-glued to section 27 so that on assembly of the unit 20, sections 27, 28, 29 and 30 form sides of the outer sleeve 22. Similarly, blank 26 has a glue flap (i) which when the blank 26 has been formed is line glued to a section 31 so that on erection of the unit 20, sections 31, 32, 33 and 34 form sides of inner base 23. When the blanks 25 and 26 have been formed and their flaps (h) and (i) glued in their respective positions, they are assembled together by sliding the inner base 23 inside the outer sleeve 22, and inserting tabs (a) in slots (b). At this stage, the sleeve 22 and the inner base 23 can lie flat as shown in FIG. 13, for convenient transport in empty condition. Lid flap 36 is left clear, as shown in FIG. 13, at this stage.

[0058] When the unit 20 is to be readied for use, outer edges of the flattened assembly of unit 20 are pushed together, so that the inner base 23 assumes its box shape, and the sleeve 22 surrounds it. At this stage, shown in FIGS. 14 and 15, the snap-lock bottom is formed up by hand, as known in the art. To finally assemble the unit 20, the inner base 23 is then pushed upwards within the sleeve 22. Tab (g) locates in slots (f) and the unit 20 has the completed form shown in FIGS. 16 to 19 and is ready for use.

[0059] The upwards force causes the sleeve unit 22 to fold along fold lines shown by broken lines in FIG. 21 and marked "CC" to "GG". This causes strut section 203 and base 204 to be pushed outwardly to form a protruding foot or extension supporting the unit 10 upright on a surface. The particular fold lines in the strut 203, as shown in FIGS. 15 and 21, again create a compound curve shape rather than a planar surface, thereby providing strength to the strut 203. The unit 10 then has the completed form shown in FIGS. 16 to 19 and is ready for use.

[0060] As best seen in FIGS. 15 and 21, the fold lines in the strut 203 that create the compound curve include a medial fold line CC running substantially parallel to the sides of the sleeve unit 22, two angled fold lines DD extending from the edge of the flap (g) to the side edges of sleeve unit 22, a base edge fold line FF running substantially perpendicular to the sides of the sleeve unit FF, two further angled fold lines EE extending from the junction of the medial CC and base edge FF fold lines to the side edges of the sleeve unit 22, and finally

two upper fold lines GG extending from the flap (g) substantially horizontally to the side edges of the sleeve unit 22.

[0061] As best seen in FIG. 16, when in the assembled state the unit 20 is slanted backwards from the vertical. Optionally, the slant angle is within a range of about 1° to 20°, and ideally about 10°. However, other angles may be used depending upon the needs and desire of the user. The units 1 and 20 have been shown with snap-lock bottoms. However, it will be recognised by persons skilled in the art that various alternative arrangements are possible for forming bottoms, such as crash-lock type bottoms which do not require an assembly step after un-flattening of the units (1 or 20) from their storage/transport condition to define a bottom.

[0062] Using attachment means other than glue as described above could also be used to assemble the blanks as would be recognised by a person skilled in the art.

[0063] Finally, certain item numbers not discussed above are shown in the figures simply to assist in understanding of the way the blanks 2, 3, 25 and 26 are folded and assembled to produce the units 1 and 20. They do not refer to faces, but to sections of their respective blanks defined by edges and/or fold lines, so that one of these numbers when shown in an assembly drawing may show the same or an opposite face to that marked with the number in a view of the corresponding unfolded blank.

[0064] Reference throughout this specification to “one embodiment” or “an embodiment” means that a particular feature, structure, or characteristic described in connection with the embodiment is included in at least one embodiment of the present invention. Thus, the appearance of the phrases “in one embodiment” or “in an embodiment” in various places throughout this specification are not necessarily all referring to the same disclosed embodiment. Furthermore, the particular features, structures, or characteristics may be combined in any suitable manner in one or more combinations.

[0065] It will be appreciated that persons skilled in the art could implement the present invention in different ways to the one described above, and variations may be produced without departing from its spirit and scope.

[0066] Any discussion of documents, devices, acts or knowledge in this specification is included to explain the context of the invention. It should not be taken as an admission that any of the material forms part of the prior art base or the common general knowledge in the relevant art, in any country, on or before the filing date of the patent application to which the present specification pertains.

1. A display unit for displaying and/or dispensing items, the unit comprising:
a sleeve part; and
a container part,
wherein the sleeve part is slidably mountable over the container part, and is slideable relative to the container part from a first pre-assembled condition to a second assembled condition,
wherein, to form the second assembled condition, sections of the sleeve part are folded about fold lines to define at least one protruding foot portion, and
wherein the fold lines cause at least one surface of the protruding foot portion to form a compound curved, non-planar surface that imparts rigidity to the unit when in the second assembled condition.

2. The display unit of claim 1, wherein said fold lines include at least one substantially vertical fold line extending about mid-way between side edges of said sleeve part, and four angled fold lines extending from said vertical fold line to said side edges.

3. The display unit of claim 1, wherein in the second assembled condition, the display unit includes a supporting surface that is angled rearwards from a vertical for displaying the items in a non-vertical orientation.

4. The display unit of claim 3, wherein the supporting surface is angled rearward by between 1° and 20° from the vertical.

5. The display unit of claim 1 wherein:

- a) the sleeve part is formed from a first shaped blank of card or other flat material and by folding about four substantially parallel first fold lines is movable between a first condition in which the sleeve part defines a sleeve of rectangular cross section in a plane perpendicular to the first fold lines and a second condition in which the sleeve part lies at least approximately flat;
- b) the container part is formed from a second shaped blank of card or other flat material and by folding about four substantially parallel second fold lines is movable between a first condition in which the container part at least partially defines a container of rectangular cross section in a plane perpendicular to said second fold lines and a second condition in which the sleeve part lies at least approximately flat;
- c) the container part is slideable within the sleeve part in a sliding direction parallel to the first and second fold lines, at least in the first condition of the sleeve part and the first condition of the container part;
- d) the sleeve part and the container part are secured to each other by connecting means so that when the container part is slid by a user in the sliding direction within the sleeve part, sections of the sleeve part are folded about the fold lines in the sleeve part and the sections define at least one the protruding foot portion of the sleeve part.

6. The display unit of claim 5, further comprising securing means whereby at one relative position of the sleeve part and the container part in the sliding direction, the sleeve part and the container part are secured to each other independently of the connecting means.

7. The display unit of claim 6 wherein said securing means includes a tab on one of the sleeve part and a cooperating opening on the container part.

8. The display unit of claim 5, wherein the container part in the first condition is open-topped.

9. The display unit of claim 6, wherein, when the securing means are operative to secure the container part in its first condition to the sleeve part in its first condition, and openings in the container part and the sleeve part align with each other and permit withdrawal of items stored in the container part.

10. (canceled)

11. (canceled)

12. (canceled)

13. The display unit of claim 2, wherein in the second assembled condition, the display unit includes a supporting surface that is angled rearwards from a vertical for displaying the items in a non-vertical orientation.

14. The display unit of claim 4, wherein the supporting surface is angled rearward by 10° from the vertical.