

(19) World Intellectual Property Organization
International Bureau



(43) International Publication Date
14 August 2008 (14.08.2008)

PCT

(10) International Publication Number
WO 2008/097915 A1

(51) International Patent Classification:
A61F 2/16 (2006.01)

(21) International Application Number:
PCT/US2008/052933

(22) International Filing Date: 4 February 2008 (04.02.2008)

(25) Filing Language: English

(26) Publication Language: English

(30) Priority Data:
60/887,933 2 February 2007 (02.02.2007) US
60/887,928 2 February 2007 (02.02.2007) US

(71) Applicant (for all designated States except US): **KEY MEDICAL TECHNOLOGIES, INC.** [US/US]; 2110 Omega Road, Suite F, San Ramon, CA 94583 (US).

(72) Inventors; and

(75) Inventors/Applicants (for US only): **MENTAK, Khalid** [US/US]; 714 Jadecrest Court, San Ramon, CA 94582 (US). **STEINACHER, Beda** [CH/CH]; Wiensenstrasse 10a, CH-8952 Schlieren (CH).

(74) Agent: **FRENCHICK, Grady, J.**; Whyte Hirschboeck Dudek S.C., 33 East Main Street, Suite 300, Madison, WI 53703-4655 (US).

(81) Designated States (unless otherwise indicated, for every kind of national protection available): AE, AG, AL, AM, AO, AT, AU, AZ, BA, BB, BG, BH, BR, BW, BY, BZ, CA, CH, CN, CO, CR, CU, CZ, DE, DK, DM, DO, DZ, EC, EE, EG, ES, FI, GB, GD, GE, GH, GM, GT, HN, HR, HU, ID, IL, IN, IS, JP, KE, KG, KM, KN, KP, KR, KZ, LA, LC, LK, LR, LS, LT, LU, LY, MA, MD, ME, MG, MK, MN, MW, MX, MY, MZ, NA, NG, NI, NO, NZ, OM, PG, PH, PL, PT, RO, RS, RU, SC, SD, SE, SG, SK, SL, SM, SY, TJ, TM, TN, TR, TT, TZ, UA, UG, US, UZ, VC, VN, ZA, ZM, ZW.

(84) Designated States (unless otherwise indicated, for every kind of regional protection available): ARIPO (BW, GH, GM, KE, LS, MW, MZ, NA, SD, SL, SZ, TZ, UG, ZM, ZW), Eurasian (AM, AZ, BY, KG, KZ, MD, RU, TJ, TM), European (AT, BE, BG, CH, CY, CZ, DE, DK, EE, ES, FI, FR, GB, GR, HR, HU, IE, IS, IT, LT, LU, LV, MC, MT, NL, NO, PL, PT, RO, SE, SI, SK, TR), OAPI (BF, BJ, CF, CG, CI, CM, GA, GN, GQ, GW, ML, MR, NE, SN, TD, TG).

Published:
— with international search report

[Continued on next page]

(54) Title: INTERFACIAL REFRACTION ACCOMMODATING LENS (IRAL)

FIG. 1

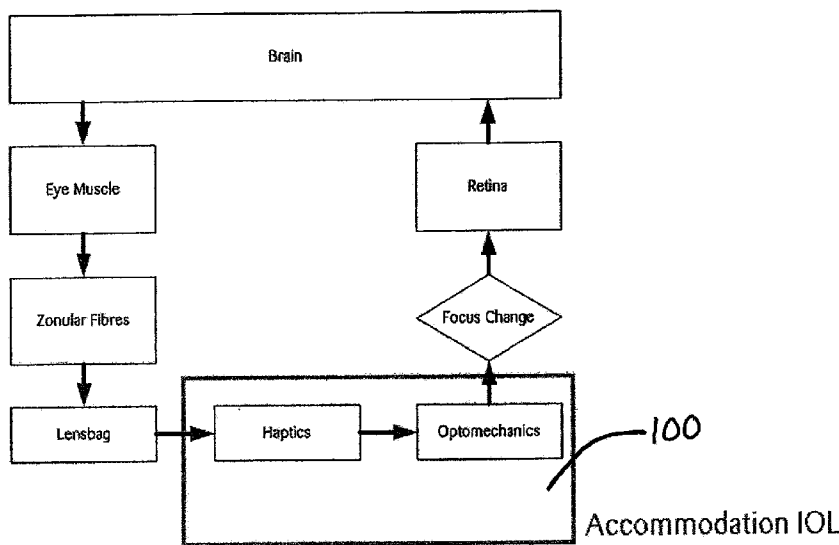

(57) Abstract: This invention relates to intraocular lenses. More particularly, this invention relates to intraocular lenses that have the ability to alter the light refractive power in response to changes in the tension of the ciliary muscle or ciliary body of the eye or any other accommodative forces. Lenses of this invention are generally referred to as interfacial, i.e., lens properties being defined as the interface of two liquids having different refractive indices, refractive accommodating lenses (IRAL).

WO 2008/097915 A1



-
- *before the expiration of the time limit for amending the claims and to be republished in the event of receipt of amendments*

INTERFACIAL REFRACTION ACCOMMODATING LENS (IRAL)

CROSS REFERENCE TO RELATED APPLICATIONS

[0001] The priority is claimed of U.S. provisional applications Serial Numbers 60/887,933 and 60/887,928 both filed on February 2, 2007, the disclosures of which are incorporated by reference herein (including any references incorporated by referenced in either or both of said provisional applications) in their entireties.

FIELD OF THE INVENTION

[0002] This invention relates to intraocular lenses. More particularly, this invention relates to intraocular lenses that have the ability to alter the light refractive power in response to changes in the tension of the ciliary muscle or ciliary body of the eye or any other accommodative forces. Lenses of this invention are generally referred to as accommodating lenses.

BACKGROUND OF THE INVENTION

[0003] The natural lens of a human eye is a transparent crystalline body, which is contained within a capsular bag located behind the iris and in front of the vitreous cavity in a region known as the posterior chamber. The capsular bag is attached on all sides by fibers, called zonules, to a muscular ciliary body. At its rear, the vitreous cavity, which is filled with a gel further includes the retina, on which light rays passing through the lens are focused. Contraction and relaxation of the ciliary body changes the shape of the bag and of the natural lens therein, thereby enabling the eye to focus light rays originating from objects at various distances on the retina.

[0004] Cataracts occur when the natural lens of the eye or of its surrounding transparent membrane becomes clouded and obstructs the passage of light resulting in

varying degrees of vision impairment. To correct this condition in a patient, a surgical procedure is performed in which the clouded natural lens, or cataract, is extracted and replaced by an artificial intraocular lens. During cataract surgery, the anterior portion of the capsular bag is removed along with the cataract, and the posterior portion of the capsular bag, called the posterior capsule, is sometimes left intact to serve as a support site for implanting the intraocular lens (IOL). Such conventional IOLs, however, have the drawback that they have a fixed refractive power and are therefore unable to change their focus in response to changing focal distance needs of the patient, such as reading, or working on a computer.

[0005] Various types of intraocular lenses having the capability of altering their refractive power have been suggested in an effort to duplicate the performance of the natural lens within the eye. Such accommodating intraocular lenses, as they are known in the art, have a variety of designs directed to enable the patient to focus on, and thereby clearly see, objects located at a plurality of distances. Examples may be found in such publications as U.S. Pat. No. 4,254,509; U.S. Pat. No. 4,932,966; U.S. Pat. No. 6,299,641; and U.S. Pat. No. 6,406,494.

[0006] U.S. Pat. No. 5,443,506 to Garabet discloses a variable focus intraocular lens which alters the medium between the two surfaces the lens to alter its accommodation. The lens of the '506 patent has continuous flow loops which couple a channel in first portion of the intraocular lens. The continuous flow loops, in addition to providing a channel, provide the means by which the intraocular lens is positioned and held in the eye. In one embodiment, the continuous flow loop(s) comprise the lens haptics i.e., the lens body supporting structures.

[0007] U.S. Pat. No. 5,489,302 discloses an accommodating intraocular lens for implantation in the posterior chamber of the eye. This lens comprises a short tubular rigid frame and transparent and resilient membrane attached thereto at its bases. The frame and the membranes confine a sealed space filled with a gas. The frame includes flexible regions attached via haptics to the posterior capsule. Upon

stretching of the capsule by the eye's ciliary muscles, the flexible regions are pulled apart, thereby increasing the volume and decreasing the pressure within the sealed space. This changes the curvature of the membranes and accordingly, the refractive power of the lens.

[0008] U.S. Pat. No. 6,117,171 discloses an accommodating intraocular lens which is contained inside an encapsulating rigid shell so as to make it substantially insensitive to changes in the intraocular environment. The lens is adapted to be implanted within the posterior capsule and comprises a flexible transparent membrane, which divides the interior of the intraocular lens into separate front and rear spaces, each filled with a fluid having a different refractive index. The periphery of the rear space is attached to haptics, which are in turn attached to the posterior capsule. Upon stretching of the capsule by the eye's ciliary muscles, the haptics and hence this periphery is twisted apart to increase the volume of rear space and changes the pressure difference between the spaces. As a result, the curvature of the membrane and accordingly, the refractive power of the lens changes.

[0009] Another approach to varying the focus of an IOL is to form a conventional hard intraocular lens with a flexible outer surface made from a material such as silicone. Water is then injected in between the conventional hard portion of the lens and the flexible outer surface of the lens. The water will stretch the outer flexible layer to change the radius of curvature of the intraocular lens and thereby change the accommodation of the lens. One disadvantage of this approach is that a fluid source, a fluid pump and a flow control valve all must be provided within close proximity to the lens. As the area around the crystalline lens of the eye is quite confined, most of the fluid injection components have to be provided on the lens itself. Further, an energy source must be provided to pump the fluid. As there is no mechanical force generated in the eye that is strong enough to pump the fluid, an external power supply is required to run the pump. Such an external power supply is usually implemented using a battery which has a limited life cycle.

[0010] A further approach that has been used to vary the accommodation of an IOL is the coating of a conventional IOL with a liquid crystal material. A voltage source is applied to the crystal material to polarize the crystals. Once the crystals are polarized the refractive index of the crystalline material changes thereby changing the accommodation of the IOL. One principal disadvantage of this type of system is the relatively large amount of energy that is required to polarize the liquid crystal material, on the order of 25 volts. As there is no known manner of generating that level of voltage within the body, an external power source, such as a battery, is therefore necessary.

[0011] Some conventional accommodating IOLs rely on a solid curved surface to provide refraction. As such the force required for a change of curvature significant enough to induce an increase in diopter and accommodating power is much larger than that provided by the ciliary muscles especially in an aging lens. Other accommodating IOLs involve a displacement of the whole IOL along the optical axis to create accommodation. This does not only require a relatively larger force but also fails to deliver larger changes in diopter due to the lack of space in the anterior chamber.

[0012] The above described and other prior attempts to provide an intraocular lens with variable accommodation are generally complex systems. These complex systems are costly and difficult to manufacture and often times impractical to implement in the eye of a human. Therefore, current accommodating lenses provide little accommodating power (about 1 to 2.5 diopters "D"). A true accommodating lens with vastly improved performance should have at least about 4D, preferably at least about 6D or more of accommodating power. Therefore, a need exists for a simple IOL with greater levels of accommodating power that relies only on the forces provided by the human eye for operation.

SUMMARY OF THE INVENTION

[0013] The present invention addresses the shortcomings of prior art lenses and lens assemblies through the use of a novel refraction system based on the interface naturally created between two immiscible liquids. A significant change in refractive power can be achieved in a practice of this invention with application of minute vertical forces and force changes e.g., by the ciliary muscle or ciliary body, without the need for movement of the IOL through the optical axis.

[0014] The IOL of the present invention comprises a lenticular chamber where two immiscible liquids are in contact with each other forming a meniscus. The interface between the two liquids provides the refractive surface that bends light into a focal point on the retina. The meniscus curvature and thus the focus of the lens is changed by applying pressure on the periphery of the lens generally by means of the lens haptics. A very small force e.g., by ciliary muscle contraction applied to the haptics is required to cause a significant change in meniscus curvature, which in turn changes the diopter of the lens to provide focus on objects at various distances. The force is transmitted from the ciliary muscles to the meniscus through the haptics. The haptics may be formed into several configuration including C-loop, modified C-loop, square, disk-like, plate, etc.

[0015] Another aspect of the present invention is the use of a transducing element to convert the ciliary muscle force into an electrical impulse. The said electrical impulse induces a change in surface energy in a specific area of the liquid filled chamber causing a steepening of the meniscus.

[0016] A variety of liquids may be used for this invention. The most important parameters are clarity, surface energy, density, viscosity and refractive index. Virtually any liquid combination may be used. The accommodating power for a variety of liquid combinations was calculated based on the change in meniscus curvature. The following Table 1 summarizes some of those results.

[0017] In another embodiment of this invention, the liquids are only optionally immiscible (i.e., they may be miscible). In that embodiment, the liquids would be separated by an optically acceptable membrane or film. The film would keep miscible liquids separated and would confine fluids I and II so as to produce a variable diopter change according to the invention. The film or membrane is applied to the edge of the discs so that mixing of the miscible liquids having differing refractive indices (RI) is prevented.

Design	Liquid I	Liquid II	Change in Diopter (D per deg of deformation angle)
1	Normal saline (0.9%) RI=1.331	Silicone fluid RI = 1.433	7.5
2	Normal saline (0.9%) RI=1.331	Silicone fluid RI = 1.454	9
3	Normal saline (0.9%) RI=1.331	Silicone fluid RI = 1.501	11
4	Normal saline (0.9%) RI=1.331	Silicone fluid RI = 1.520	15
5	Normal saline (0.9%) RI=1.331	Acrylic fluid RI = 1.512	10.5
6	Normal saline (0.9%) RI=1.331	Acrylic fluid RI = 1.536	12.7
7	Normal saline (0.9%) RI=1.331	Organic oil RI = 1.467	7.5
8	Normal saline (0.9%) RI=1.331	Organic oil RI = 1.502	10.5

Table 1

[0018] The advantages of the method and accommodating IOL of the present invention are not here-to-for known to the art:

1. Stable refraction since the interface between two immiscible liquids is naturally stable due to free energy considerations.
2. The interface can be moved with minute forces. This allows a change of curvature with minimal forces from ciliary muscles and hence significantly larger diopter changes.

3. The design is relatively simple and similar to that of conventional IOLs. Essentially, square edges may be incorporated into the design to prevent posterior capsule opacification (PCO)

The lens affords true accommodation and substantially increased lens diopter changes not here-to-for known to the art.

[0019] Thus, in one aspect, the present invention is a method of obtaining diopter changes, by means of an accommodating IOL, of at least 2 diopters, preferably at least 4 diopters; and most preferably at least 6 diopters in response to an implanted IOL patient's physiologic demand for such change. In a very real sense, the present accommodation method and accommodating IOL apparatuses closely mimics the lens focus adjustment and response of a young, healthy, pre-cataractus eye.

[0020] The term "capsular unit", as it is used in the present description and claims, refers to the posterior capsule, the zonules, and the ciliary body, which are interconnected and act in unison, forming in accordance with the present invention, a kind of cable whose varying tension provides the axial force applied to and utilized by the lens assembly of the present invention to achieve accommodation.

[0021] A lens of the present invention is a substitute for a natural lens after its removal from the eye, not only by enabling the eye to see better (or at all) after implantation of the assembly, but also by enabling it to accommodate and thereby bring into focus objects located at a continuum of distances. In order to achieve accommodation, the assembly is designed to be fixed in the posterior chamber, in the capsular bag or sulcus, with the resilient body axially abutting the posterior capsule or the sulcus.

[0022] The lens assembly of the present invention utilizes the natural compression and relaxation of the capsular unit or sulcus to impart an axial force on the resilient body in order to cause it to act as a lens whose radius of curvature, and therefore the refractive power it provides, varies depending on the magnitude of the force. In this way, the lens assembly cooperates with the natural operation of the eye to accommodate and enable the eye to see objects more clearly at different distances.

[0023] The haptics element of the assembly according to the present invention may adopt any of a variety of designs known in the art, e.g. it may be curved or it may be in the form of a plate. In addition, the haptics element may be completely transparent or opaque. The haptics element of the lens assembly in accordance with the present invention may be made of a variety of possible rigid materials suitable for invasive medical use and known in the art to be used in the formation of haptics.

[0024] The advantages provided by the accommodating lens assembly of the present invention are many. The lens assembly does not need to conform to the size or shape of the capsule, and is therefore free to take on a larger variety of designs. Furthermore, the capsule is sometimes damaged during the surgery to remove the natural lens, but the lens assembly of the present invention does not require that the capsule be completely intact in the form of a bag but merely that it remain reliably connected as part of the capsular unit. Another advantage arising from the lens assembly being positioned outside of the posterior capsule is that it remains unaffected by the permanent and unpredictable constriction that the capsule inevitably undergoes due to scarring following the surgery for removal of the natural lens, usually referred to as capsule fibrosis, which occurs in all patients and at varying degrees. For conventional accommodating IOLs relying on lens optic forward movement to provide accommodation, capsule fibrosis immobilizes IOLs and limits forward movement of the optic causing inconsistent clinical outcome and limited accommodation range. The IOL of the present invention does not require the optic to move forward.

[0025] Further, in one embodiment, the lens of this invention is foldable. In this embodiment the lens comprises optically-acceptable, foldable materials. Thus all of the advantages of a foldable IOL known to one skilled in this art are provided.

[0026] In addition to the above, the lens assembly of the present invention offers advantages such as a simple and inexpensive construction. The lens assembly of the present invention also provides the ability to accommodate within a vast range of refractive power, including the full range provided by the natural eye and much more

if needed in case of other eye diseases such as age related macular degeneration (AMD). Also, the lens assembly provides means for varying its sensitivity in response to the force applied by the capsular unit. In addition, the lens assembly is similar in design to conventional monofocal IOLs and can be implanted using existing surgical instruments and techniques. No special surgical skills or training is required.

BRIEF DESCRIPTION OF THE DRAWINGS

[0027] In order to understand the invention and to see how it may be carried out in practice, a preferred embodiment will now be described, by way of non-limiting example only, with reference to the accompanying drawings, in which:

[0028] FIG. 1 is a flow chart showing the interaction between an accommodation IOL and a patient's optical sensory mechanism to provide improved visual acuity.

[0029] FIG. 2 is a front view of an Interfacial Refraction Accommodating Lens or Lens Assembly (IRAL) in accordance with the present invention;

[0030] FIG. 3 is a cross-sectional view of the IRAL shown in FIG. 2; and

[0031] FIG. 4 is a perspective view of a second embodiment of the present invention in which the direction of the application of force to the haptics by the ciliary muscle is illustrated by arrows (11). The accommodating lens of FIG. 4 also has a different haptic configuration from the lens of FIGS. 1 and 2.

[0032] FIG. 5 is a perspective view of a piezoelectric or electrical accommodating lens embodiment of the present invention.

[0033] FIG. 6 shows a further embodiment of the present invention in which 6A shows an IOL of this invention in the accommodated state and 6B shows the same IOL as is shown in FIG. 6A in an unaccommodated state.

[0034] FIG. 7 shows, at FIGS. 7A and 7B, accommodated and unaccommodated state yet a further version of an IOL of this invention.

[0035] FIG. 8 shows yet a third accommodating IOL of this invention in cross section.

[0036] FIG. 9 is an IOL as shown in FIG. 8 in an unaccommodated state i.e. the haptics not being posteriorly-disposed.

[0037] FIG. 10 shows the lens of FIG. 9 in section taken along line 10A-10A of FIG. 9, the direction of view being to the right (posteriorly).

[0038] FIGS. 11-13 illustrate in side view, a top view, and in section along line 13-13 of FIG. 12, respectively, a further accommodating IOL of the present invention.

[0039] FIG. 14 shows the IOL of FIG. 13 in an accommodating state, the haptics being slightly bent, depressed or moved in the direction of the arrows toward the bottom of the figure.

[0040] FIG. 15 shows an implantation site of an IOL of the present invention, the IOL being in an accommodated state.

[0041] FIG. 16 shows the IOL of FIG. 15, as implanted, in an unaccommodated state.

[0042] FIGS. 17, 18 and 19 show in side-view, in top view, and in section, respectively, the further embodiment of an IOL of this invention.

[0043] FIGS. 20 and 21 show an implantation site of the IOL of FIGS. 17-19 in an accommodated, and unaccommodated state, respectively.

[0044] FIGS. 22, 23 and 24 show a further embodiment of the present invention in side view, top view and section taken along line 24-24 of FIG. 23.

DETAILED DESCRIPTION OF THE INVENTION

[0045] The basic principles of accommodating lenses are, of course, well known to one skilled in the art. These principles are illustrated at FIGS. 1 and 2 (and associated disclosure at column 4 line 20 through line 52) of U.S. Patent 5,489,302 that disclosure being specifically incorporated by reference herein.

[0046] Generally, in one aspect, this invention is an implantable interfacial refraction ophthalmic lens (IRAL) assembly or apparatus which adjusts its focal distance in response to changing physiologic needs of the user of said lens (e.g., a patent in which the lens has been implanted.). The lens comprises a flexible optic chamber lens body, or optic and cooperating haptics. The optic chamber is defined by opposed, substantially parallel visually transparent, generally circular discs, which are flexibly coupled at their edges and spaced apart to define a closed fluidic chamber. The fluidic chamber includes first and second liquids, the liquids having different refractive indices the difference being ΔRI and, in one embodiment, being immiscible so as to define a changeable or changing spherical or lenticular interface therebetween. The haptics are coupled to the edge of the optic chamber and to the fluidic chamber so that application of force to the haptics deforms the fluidic chamber and changes the sphericity of the liquid interface. Thus, the focal length of the lens assembly changes in response to application of force to the haptics to change the visual focus of the user.

[0047] In one embodiment, the fluids are optionally immiscible and are separated by a membrane which is sealed to the edge of the disc(s) to define flexible fluidic chamber.

[0048] This invention also includes a method of correcting visual activity by the use of an accommodating IRAL, the method comprising the steps of:

replacing a defective natural lens of an eye of a patient in need of such replacement with an accommodating IRAL;

permitting the IRAL to accommodate the patient's need to change the focal point of the eye e.g., the retinal focus, by changing the diopter strength and thus the focal point of the IRAL wherein the diopter strength change of the IRAL is at least 2 diopters;

and wherein the IRAL employs liquids having different refractive indices to define to change diopter strength and thus the interface.

[0049] FIG. 1 is a flow chart showing the optomechanical principle which permit an accommodating lens e.g., an accommodation IOL, to interact with physiologic, optical signals to provide better near and distance visual acuity to a user of the lens. In short the brain instructs the muscular ciliary body (eye muscle) to contract. That muscular contraction applies a subtle, generally posteriorly-directed, force to a lens haptics (discussed below) via the zonular fibres. That force applied to the haptics causes the optical power of the accommodating lens to change thereby focusing in-coming light onto the retina with greater accuracy and with increased clarity. Box 100 shows generally the functions of the haptics and coupled optomechanics of an accommodating or accommodation IOL, such as a lens of this invention, in that process. The haptics center the IOL in the focal zone or focal axis of the eye and receive and transmit ciliary muscle force to the optic chamber or lens body (described in greater detail below). The haptics can be in direct contact with eye muscle if the accommodation IOL is implanted into the sulcus. The optomechanics of an accommodating IOL of the invention then converts the ciliary muscle force into diopter changes of the lens.

[0050] FIG. 2 is a front view of an interfacial refraction accommodating lens (IRAL) of the present invention. In FIG. 2 there is shown a lens assembly 10 comprising an optic chamber or lens body 12 and haptics 14. It will be understood that haptics 14 shown in FIG. 2 are only one possible haptic configuration, there being many others which will readily occur to one skilled in this art in view of this disclosure. Also shown within optic chamber 12 by a dotted circle 16, 16' is the

position of the refractive surface (i.e. the interface between the two fluids) upon responding to the force exerted by the ciliary muscles.

[0051] FIG. 3 is a cross-sectional view of the IRAL shown in Fig. 2 showing the relationship between haptic deformation or displacement angle 15, 15' and the change in interfacial radius of curvature 16, 16' achieved by very small haptic deformation angle changes. The change in the shape of the interface 16 shown in Fig. 2 illustrates the increase in radius of curvature of the refractive surface upon changes in haptic pressure. Changes in haptic pressure are obtained by changes in the deformation of the haptics which, in turn, result from increased pressure of the ciliary muscle or capsular bag. As is shown, the radius of curvature of the interior envelope 16, 16' changes in response to haptic deformation angle changes. That change in radius of curvature in conjunction with the Liquids I and II (having a refractive index characteristics detailed below) create substantial dioptic changes for very small ciliary muscle movement(s). Changes in diopter per degree change in deformation angle for various Liquids I and II are shown in Table 1 above. Clearly the invention provides diopter changes which are substantially in excess of anything disclosed in the prior art. Thus, for example, diopter changes (and accommodation as discussed above) in the range of four diopters, preferably six diopters, and most preferably about 7.5 diopters or more are obtained in once practice of this invention.

[0052] FIG. 4 is a perspective view of another embodiment of the present invention in which the direction of application of force, e.g., by a ciliary muscle is shown at arrows 11. Haptics 14 are of a further partial loop variation consistent with the teachings of this invention. Further embodiments of optic chamber, fluid chamber, or lens body 12 are discussed below.

[0053] FIG. 5 illustrates an electrical or piezoelectric design or approach to the present invention. As is noted, a transducer element or circular haptic 40 is coupled or connected via the connecting or coupling element 42 to fluid chamber 44. In accordance with this approach, movement of the transducer element-haptic 40 by the

user's ciliary muscle causes an electrical signal to be transmitted, via conducting element 42 to fluid chamber 44. Accommodation in the eye is induced by the contraction of ciliary muscles (not shown) and capsular bag (not shown). A method of this invention involves a transducing element 40 sensing the ciliary muscle force and generating an electrical current or voltage through lens chamber 44. The electrical voltage induces a change in surface energy along the surface of chamber 44 which in turn causes a steepening of the curvature of the interface between the two liquids. In one aspect, then, this invention is an accommodating IOL where the change in the interface curvature is directly induced by the electrical impulse generated by the ciliary muscle during contraction. In this embodiment, the haptic is made from a conducting material. A conducting element could also be embedded in the haptic.

[0054] A transducer capable of converting the ciliary muscle or capsular bag movement into an electrical signal is used to effectively change the shape of the meniscus and allow accommodation. The transducer can be a piezoelectric device, a force sensor, an actuator or any other element capable of converting a force into an electrical signal. The haptics may be made from a force sensing element. The haptics may be formed into several configuration including C-loop, modified C-loop, square, disk-like, plate, etc.

[0055] The materials chosen to practice this invention will be readily apparent to one skilled in this art. In one embodiment, haptic materials may include PMMA, PVDF, PP, or other polymers. Optic chamber 12 materials can include hydrophobic acrylic polymers or copolymers (HAC), hydrophilic acrylic polymers or copolymers, silicone polymers or copolymers (PDMS) or other polymers. Preferred polymers include PDMS or HAC. (12 and 16 are made from the same material). As is noted the relationship between refractive indices of Liquids I and II are required in order to obtain the advantages of the present invention.

[0056] Reference is now made to FIG. 6-14 in which several further embodiments of this invention are shown. In these FIG. 6, the anterior side of the

implant, lens body or lens assembly 20 is generally to the left; posterior 22 generally to the right. The lens body or optic chamber generally comprises discs 24, 26 which are flexibly coupled at their edges 28. As is shown flexible coupler or sidewall 28 is compressible and provides an annular connection between discs 24, 26, coupler 28.

[0057] Because discs 24, 26 are spaced apart along the focal axis of the eye (when implanted) a closed fluidic chamber 30 is defined. Chamber 30 contains immiscible liquids 32, 34 having differing refractive indexes according to this inventor. Generally, the higher refractive index liquid will be posteriorly disposed in lens body 34, with the lower refractive index liquid 32 being anterior.

[0058] Due to the immiscible liquids 32, 34 a spherical curved interface 36 is formed. At its perimeter the interface has a fixed contact angle 40A at the interface to the implant sidewall 28. The curvature of this liquid interface depends on the properties (surface tensions) of the liquids and the implant material. It corresponds to an energy minimum. Force from the eye muscle is transmitted to the implant by haptics schematically shown by arrows 42, the bolder arrow indicating greater force. This applied force deforms a sidewall 28. Because of the fixed contact angle 40 a change in sidewall inclination will change the radius of the liquid interface 36 (an energy minimum is attained). A change in radius will lead to a change in optical power i.e., diopter rating of the device 10. In this manner the focal length of the IOL will change to provide a better focus of impinging light on the retina (not shown).

[0059] In FIG. 7, a variation is shown in which the force from the eye muscle is transmitted to the implant by haptics to a displaceable annular sidewall 50. The applied force shown by arrows 52 pushes the liquid interface along the variable curved sidewall 50. This is done by deforming hinge-like structure 56, which is integrated into the implant. One can think of other possible mechanical solutions to achieve the movement of the liquid interface along the structured sidewall 50. As the inclination of the sidewall 54 changes, the liquid interface will adapt its curvature to achieve the

fix contact angle. This corresponds to an energy minimum. A change in radius will lead to a change in optical power of the device.

[0060] Due to the immiscible liquids a spherical curved interface 36 is formed. At its perimeter 54 the interface has a fixed contact angle to a movable ring structure within the implant 10. The curvature of this liquid interface depends on the properties (surface tension) of the liquids and the implant material. The force from the eye muscle is transmitted to the implant by haptics. FIGS. 8, 9, and 10 illustrate a further embodiment of the invention. Haptics 80 in this embodiment are interiorly coupled to a moveable interior ring 81. Force applied at arrows 82 moves the ring structure 81 within the implant. The movable ring structure could be made out of a different materials (e.g., having a high stiffness) than the implant. As the ring structure is swept across the liquid interface a certain radius of the liquid interface will be formed that corresponds to an energy minimum. The change in radius thus will lead to a change in optical power of the implant.

[0061] FIG. 11-14 illustrates a lens where both the static power and accommodative power also are generated by the interface between the two liquids. The implant is designed such that the haptics are in contact with the sulcus. Designs where the implant sits in the lensbag are also feasible. In the design four haptics 90 are shown, which are in contact with sulcus. One can think of designs with less or more haptics. In the accommodated state the contracted ciliary muscle pushes the haptics in direction of the vitreous. This will lead to a movement of the ring within the implant in the opposite direction. The liquid interface will form a certain radius which corresponds to an energy minimum (depending on the design of the ring structure and materials involved). Arrows 98 generally show the direction of shift in haptic 90 deformation to achieve the accommodated or accommodation state. In FIG. 14 the curvature of the liquid interface is increased compared to the unaccommodated state 96 (FIGS. 11, 12, and 13) and the optical power of the implant increases.

Computation of Lens Parameters

[0062] Results were obtained using the following formula (paraxial approximation)

$$\text{Radius Liquid Interface} = \frac{\Delta RI}{\text{Static Power}}$$

[0063] Results were obtained using the following formulas (paraxial approximation)

Radius of Liquid interface in unaccommodated state:

$$R_1 = \frac{\Delta RI}{\text{Static Power}}$$

Radius of Liquid interface in accommodated state:

$$R_2 = \frac{\Delta RI}{\text{Static Power} + \text{Accommodation}}$$

Sidewall deformation angle

$$\text{Deformation Angle} = \arcsin\left(\frac{D_{\text{Lens}}}{2R_1}\right) - \arcsin\left(\frac{D_{\text{Lens}}}{2R_2}\right)$$

[0064] Using Taylor approximation this formula can be further simplified to:

$$\text{Deformation Angle} \approx \frac{D_{\text{Lens}} \cdot \text{Accommodation} \cdot 180^\circ}{2 \cdot \Delta RI \cdot 1000 \pi}$$

where D_{lens} is in mm and Accommodation in D.

TABLE 2

Static Power [D]	$\Delta RI=0.1$ Radius Liquid Interface [mm]	$\Delta RI=0.23$ Radius Liquid Interface [mm]
10	10.0	23.0
12	8.3	19.2
14	7.1	16.4
16	6.3	14.4
18	5.6	12.8
20	5.0	11.5
22	4.5	10.5
24	4.2	9.6
26	3.8	8.8
28	3.6	8.2

TABLE 3

Accommodation [D]	$\Delta RI=0.1$ Sidewall Deformation Angle [°]	$\Delta RI=0.23$ Sidewall Deformation angle [°]
6	14.4	4.7
10	27.3	7.9
20	not possible	16.3

TABLE 4

Static Power [D]	$\Delta RI=0.13$ Radius Implant [mm]
10	13.0
12	10.8
14	9.3
16	8.1
18	7.2
20	6.5
22	5.9
24	5.4
26	5.0
28	4.6

TABLE 5

Accommodation [D]	$\Delta RI=0.1$ Sidewall Deformation Angle [°]	$\Delta RI=0.23$ Sidewall Deformation angle [°]
6	10.4	4.5
10	17.5	7.5
20	36.9	15.1

TABLE 6

Static Power [D]	$\Delta RI=0.13$ Radius Implant biconvex [mm]
10	26.0
12	21.7
14	18.6
16	16.3
18	14.4
20	13.0
22	11.8
24	10.8
26	10.0
28	9.3

TABLE 7

Accommodation [D]	$\Delta RI=0.1$ Sidewall Deformation Angle [°]	$\Delta RI=0.23$ Sidewall Deformation angle [°]
6	10.4	4.5
10	17.5	7.5
20	36.9	15.1

[0065] FIGS. 15 and 16 show generally the implant site in the eye where a lens of this invention would be located. Anterior is to the left while posterior is to the

right. Impinging light enters from the left and is to be focused upon the retina (not shown). FIG. 15 shows, e.g., a lens of FIGS. 9-14 with the contracted ciliary muscle 110 applying force to haptics 90 - so as to deform the surfaces of the immiscible liquids in lens body 10 to change of optical characteristics of the lens, i.e., to accommodate the optical need of the implant patient. The sulcus 112, vitreous 114 cornea 116, iris 118, collapsed lensbag 120, and zonules 122 eye structures are shown. FIG. 16 shows the same implant location and IOL with the ciliary muscle relaxed (an unaccommodated state).

[0066] FIGS. 17-19 show a variation in which an anterior uniconvex lens 140 is used. All other structural elements are the same.

[0067] FIGS. 20-21 shows the lens of FIGS. 17-19 as implanted.

[0068] FIGS. 22-24 shows an equiconvex or biconvex IOL 160 design of this invention. An implantation view would be similar to that as shown in FIGS. 15 and 16.

[0069] Reference is made to Tables 2 through 7 above. The above mathematical construct in conjunction with the information contained in the tables permit one skilled in the art to design an accommodating lens of this invention which is uniquely applicable to a particular patient's vision needs. "Static Power" is a measurement of a lens's power required to provide correct visual acuity at a distance, such as for driving or observing sporting events. The accommodation provided by a lens of this invention is that the same lens also provides near vision correction, e.g., such as is required for reading. Thus for any given static power determined for a patient, the Tables show the radius of curvature that is obtained for any given differential in refractive index (ΔRI) of liquids I and II (also 32, 34) contained within the optical chamber of lens body discussed above. Clearly, the greater the difference in refractive index (ΔRI) the larger the radius liquid interface and the larger the permitted lens accommodation. Sidewall deformation angles are shown for various

lens accommodations. The “ ΔRI ’s” of 0.1 and 0.23 that have been used in the Tables are to be understood as exemplary, other such differences being useable and within the contemplation of the present invention.

[0070] It is noted above that in one embodiment of the present invention, fluids having differing refractive indices are used but which are miscible. In this structure the two liquids are separated by an optically-acceptable membrane, film, or divider. The membrane would then define the interface or meniscus between the fluids (e.g., at 16, 16' in FIG. 3, 96 in FIG. 13, 36' 36 in FIGS. 6-9,) and thus the radius of curvature which determines the degree of accommodation. The membrane which separates fluids I and II would not be permeable by either fluid, would not be chemically affected by either fluid, and would be internally bonded to the edge of the optical chamber or lens body so as to prevent the liquids from mixing.

[0071] It is to be noted that an IRAL of the present invention is a completely hermetically sealed structure. The present IRAL are robust, intended for long term implantation, providing many years of near-natural lens accommodation for the patient.

[0072] IRALs of this invention are, in a preferred embodiment, foldable. In the foldable embodiment of this IRAL the lens obtains small incision implantation and other medical advantages which foldable IOLs provide. To be foldable, materials chosen for the various lens structures must have relative flexibility or rigidity so as to perform their optical intended function(s) and to provide structural integrity while also permitting the entire structure to be sufficiently soft or flexible to be stored in a folded state and to unfold when inserted in folded or rolled fashion through a small incision during the implantation procedure.

[0073] With the above structural and medical functions and the mathematical construct in mind, the selection of materials for the various lens structures will be

suggested to one skilled in this art. Optically-acceptable materials provide the requisite light transmissivity, depending upon their function, and can be implanted in the eye for long periods of time. Immune response, biodegradability (or absence thereof), and various other physiologic factors all must be considered in selecting such materials. The acrylate family of polymers, and polymer chemistry, are suggested for many of the structure of this invention.

[0074] The following patents and published patent applications are incorporated by reference herein:

US 2004/0181279

US 7,025,783

US 5,443,506

The patents discussed herein above as paragraphs 0004-0007 are also incorporated by reference herein.

[0075] It should be understood that the above described embodiments constitute only examples of an accommodating lens assembly for implantation into the eye according to the present invention, and that the scope of the present invention fully encompasses other embodiments which may become obvious to those skilled in the art. For example, while implantation of the lens assembly in humans is described, the assembly may clearly also be applicable to other animals. Clearly, any and all possible permutations and/or combinations of different features as described above are within the scope of the present invention.

CLAIMS

What is claimed is:

1. An implantable interfacial refraction ophthalmic lens assembly which adjusts its focal distance in response to changing physiologic needs of the user of said lens, the lens comprising a flexible optic chamber and cooperating haptics:

the optic chamber is defined by opposed, substantially parallel visually transparent circular discs, which are flexibly coupled at their edges and spaced apart to define a closed fluidic chamber, the fluidic chamber including first and second liquids, the liquids having different refractive indices and being immiscible so as to define a spherical or lenticular interface therebetween;

the haptics being coupled to the edge of the optic chamber and to the fluidic chamber so that application of force to the haptics deforms the fluidic chamber and changes the sphericity of the liquid interface;

whereby the focal length of the lens changes in response to application of force to the haptics to change focus of the user.

2. A method of correcting visual activity by the use of an accommodating IRAL, the method comprising the steps of:

replacing a defective natural lens of an eye of a patient in need of such replacement with an accommodating IRAL;

permitting the IRAL to accommodate the patient's need to change the focal point of the eye by changing the diopter strength and thus the focal point of the IRAL wherein the diopter strength change of the IRAL is at least 2 diopters.

3. A method according to claim 2 wherein the diopter change is at least 4 diopters.

4. A method according to claim 2 wherein the diopter change is at least 6 diopters.

5. An implantable interfacial refraction ophthalmic lens assembly which adjusts its focal distance in response to changing physiologic needs of the user of said lens, the lens comprising a flexible optic chamber and cooperating haptics:

the optic chamber is defined by opposed, substantially parallel visually transparent circular discs, which are flexibly coupled at their edges and spaced apart to define a closed fluidic chamber, the fluidic chamber including first and second liquids having different refractive indices, the liquids being separated by an optically-acceptable membrane, the membrane being bonded to the circular disc edges so as to define a spherical or lenticular interface between the liquids;

the haptics being coupled to the edge of the optic chamber and to the fluidic chamber so that application of force to the haptics deforms the fluidic chamber and changes the sphericity of the liquid interface;

whereby the focal length of the lens changes in response to application of force to the haptics to change focus of the user.

6. A lens assembly according to claim 5 wherein the lens assembly is foldable.

7. A lens assembly according to claim 6 wherein the lens is adopted to be implantable into the eye using IOL injectors.

8. A lens assembly according to claim 5 wherein the difference between the refractive indices of the first and second liquids (ΔRI) is at least about 0.1.

9. A lens assembly according to claim 5 wherein the difference between refractive indices (ΔRI) is at least about 0.2.

10. A method of correcting visual activity by the use of an accommodating IRAL, the method comprising the steps of:

replacing a defective natural lens of an eye of a patient in need of such replacement with an accommodating IRAL;

permitting the IRAL to accommodate the patient's need to change the focal point of the eye by changing the diopter strength and thus the focal point of the IRAL wherein the diopter strength change of the IRAL is at least 2 diopters;

wherein the IRAL employs liquids having different refractive indices to define the interface.

11. A method according to claim 10 wherein the IRAL diopter strength change occurs in response to ciliary muscle contraction.

12. A method according to claim 11 wherein the IRAL uses a piezoelectric response to change the interface.

13. A method according to claim 11 wherein the IRAL uses mechanical application of force to change the interface.

1/18

FIG. 1

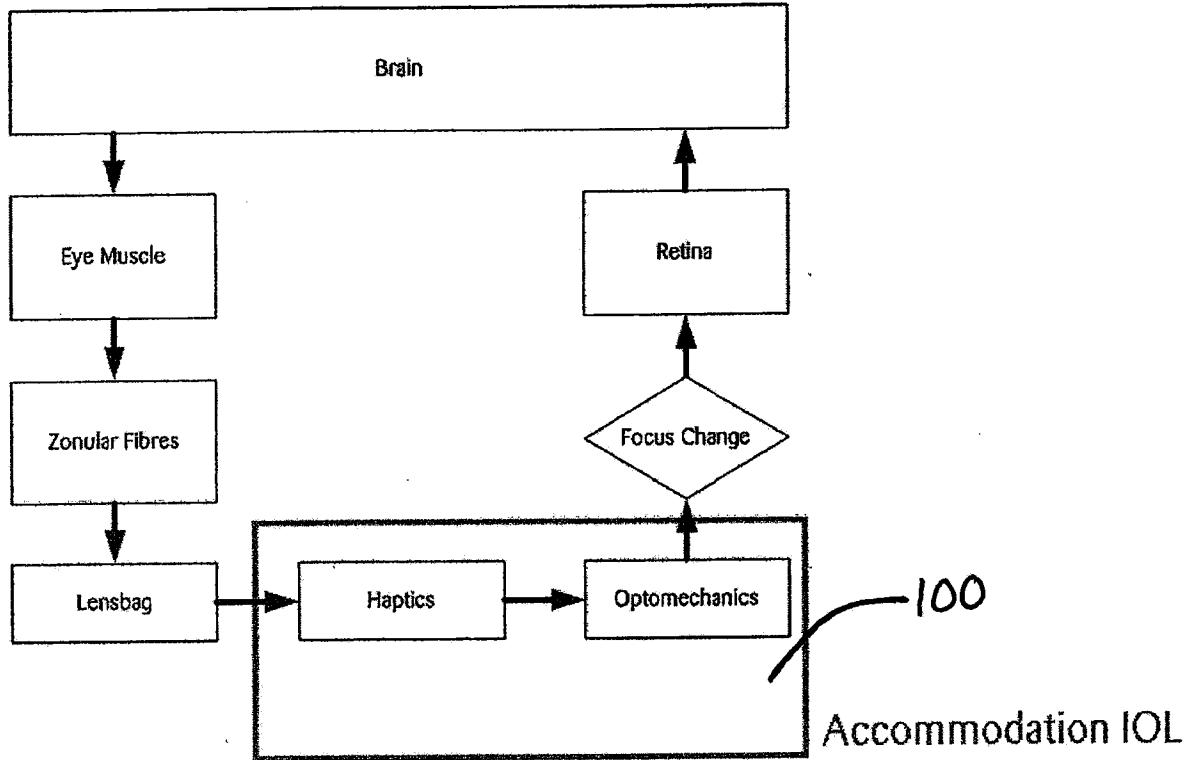

2/18

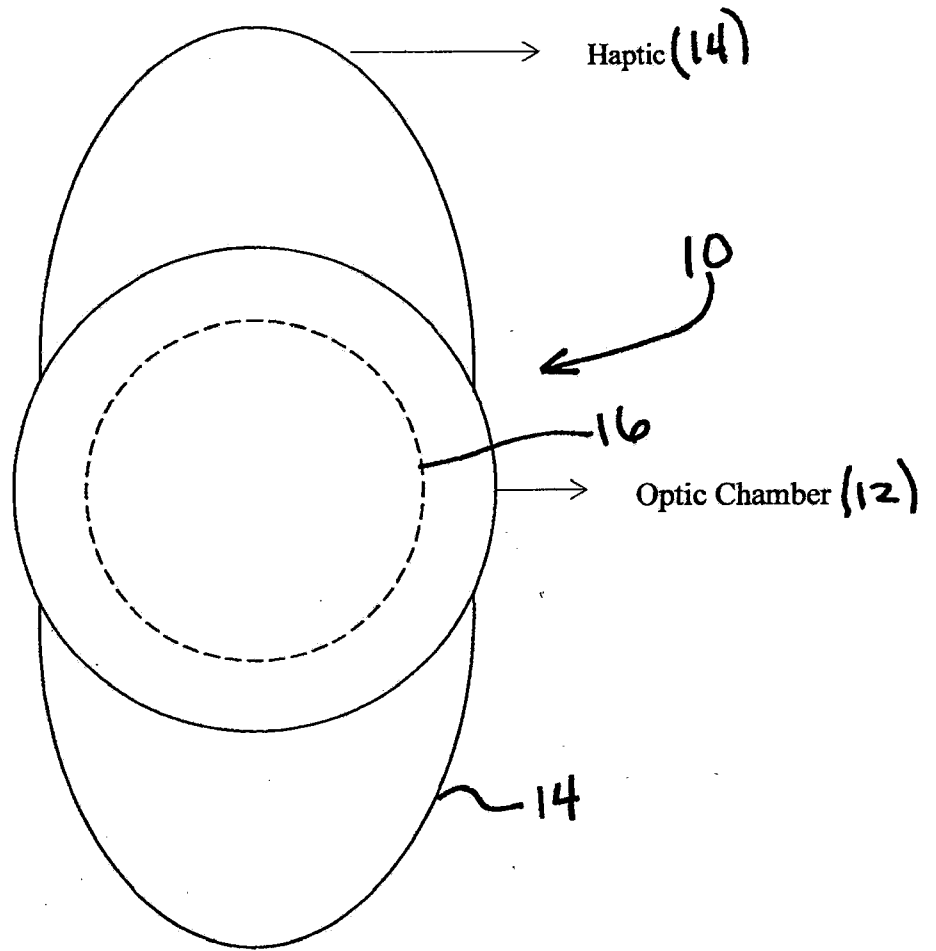

Fig 2 Front view of IRAL

3/18

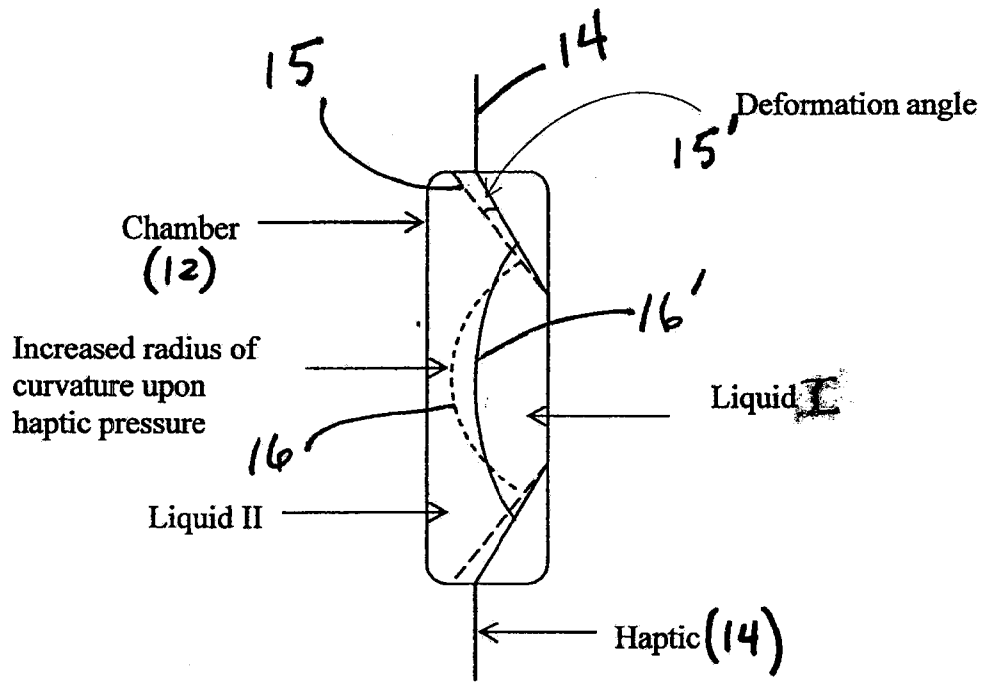

Fig 3 Cross-section of IRAL showing dioptric change induced by haptic pressure

Mechanical Design

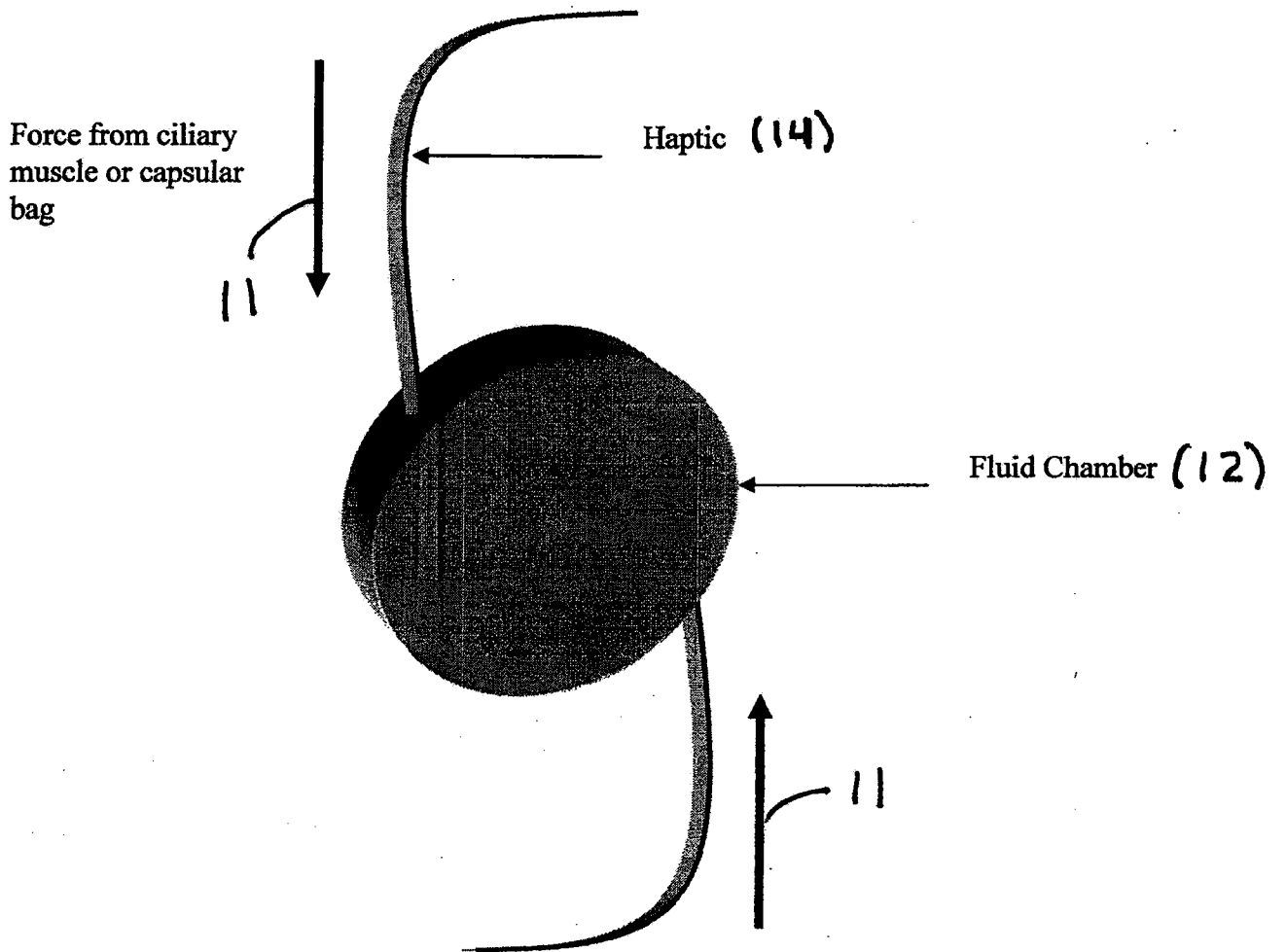

FIG. 4

5/18

Electrical design

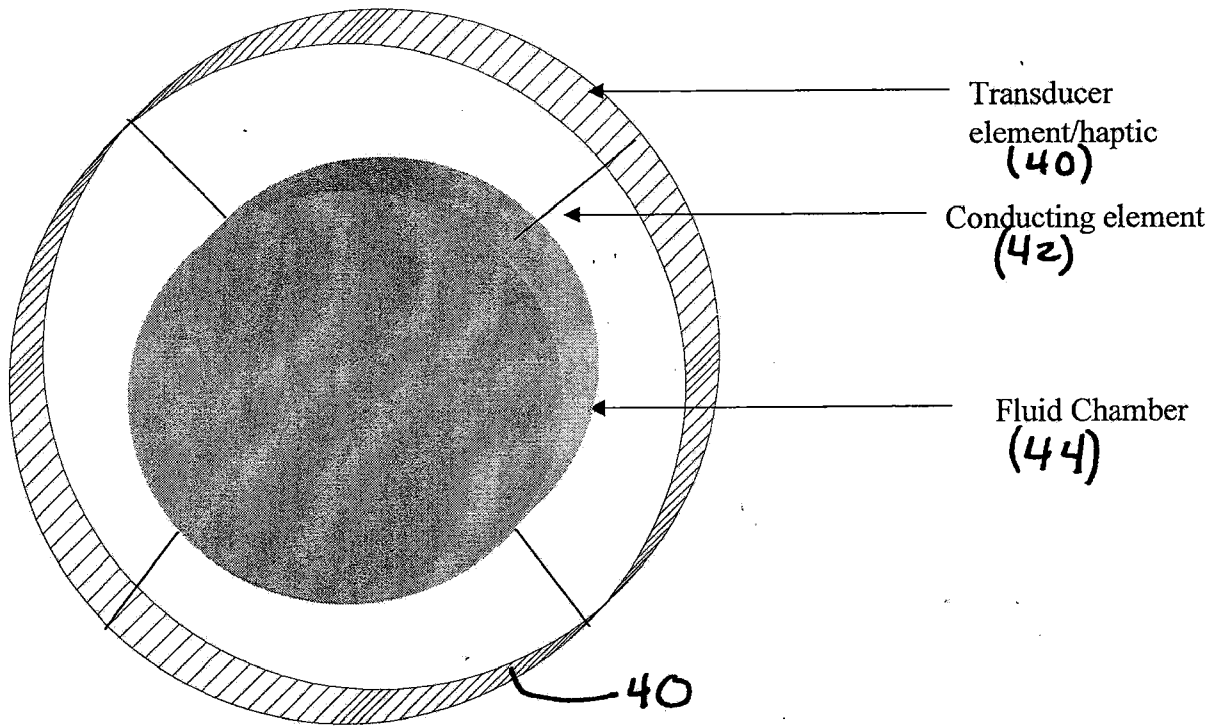

FIG. 5

FIG. 6

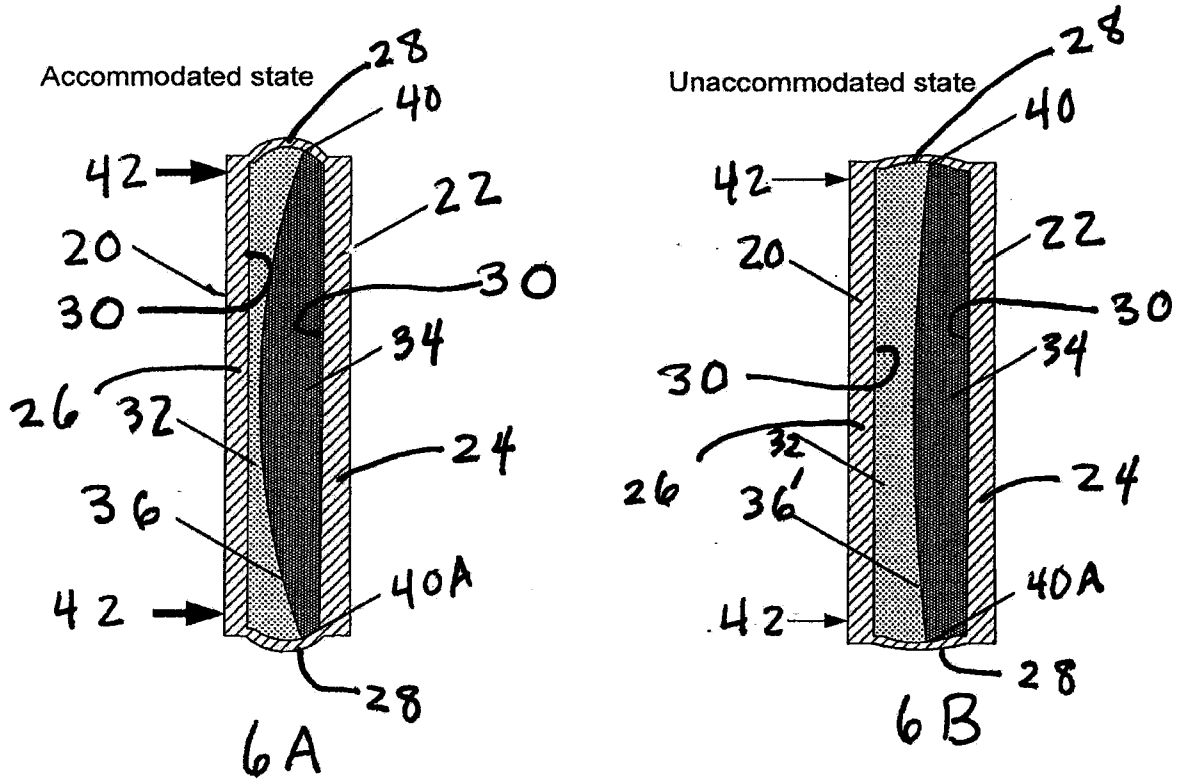
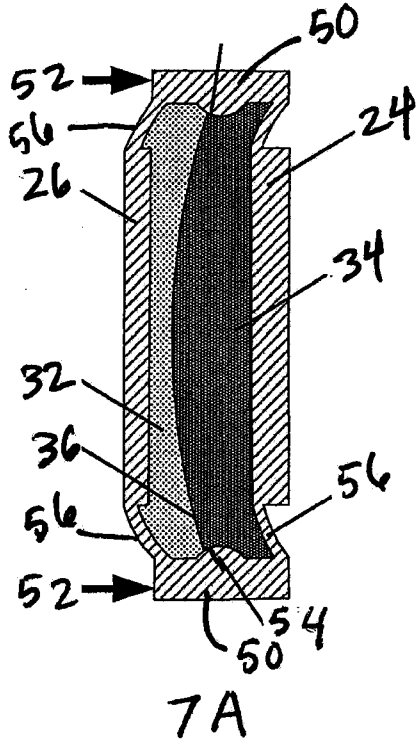

FIG. 7

Accommodated state



Unaccommodated state

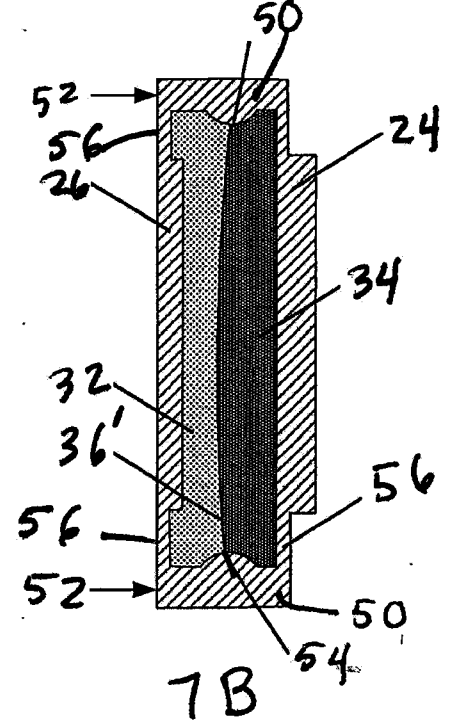
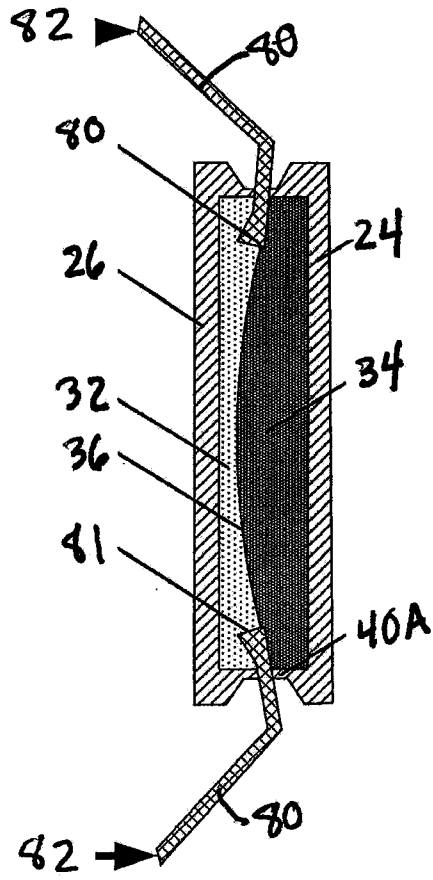

FIG. 8

Accommodated state



9/18
FIGS. 9, 10

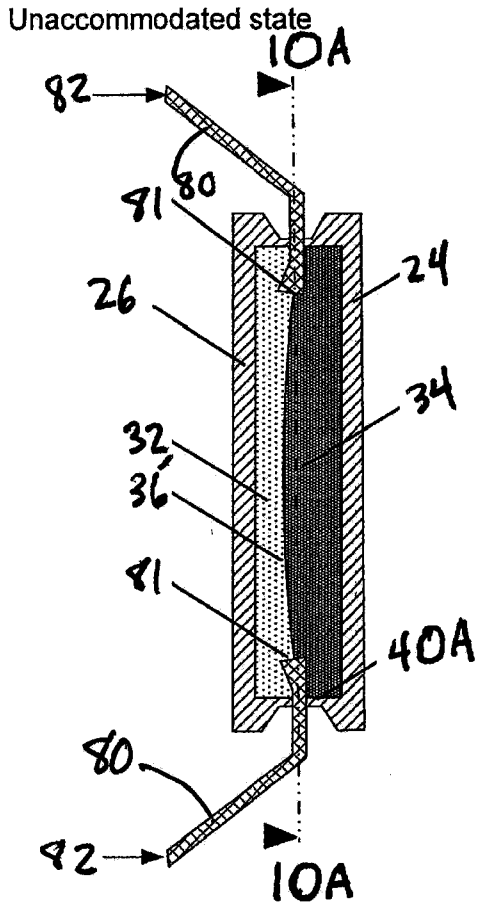

FIG. 9

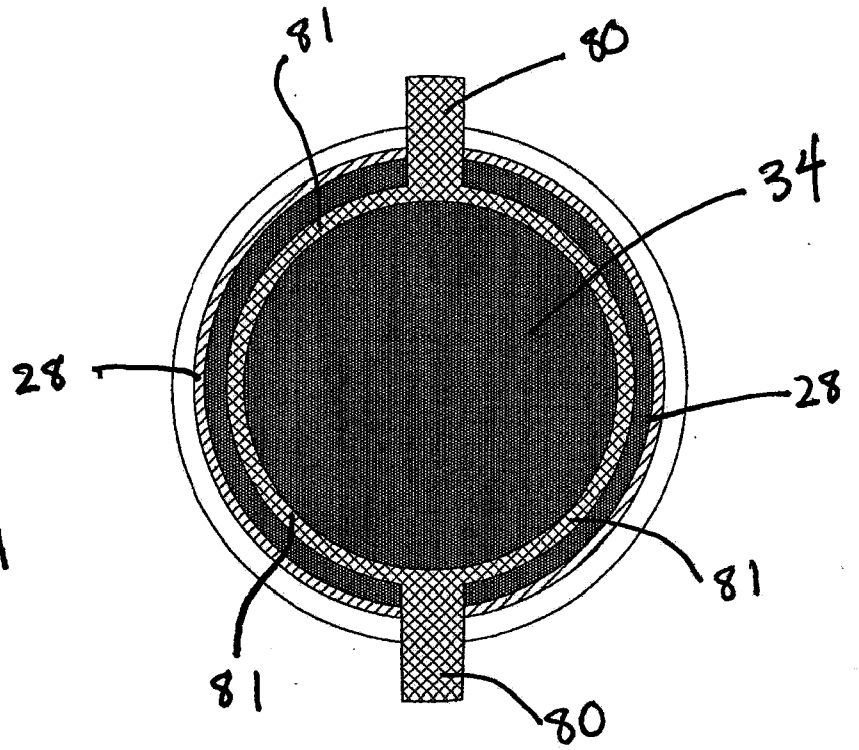

FIG. 10

10/18

FIG. 11

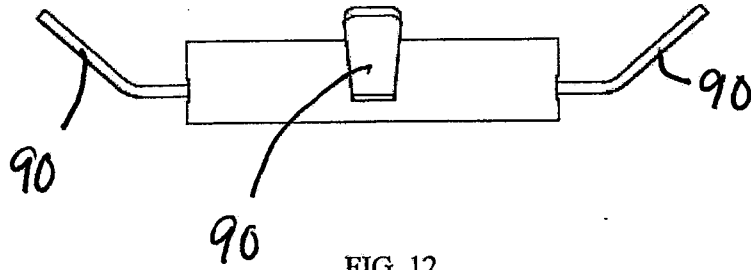
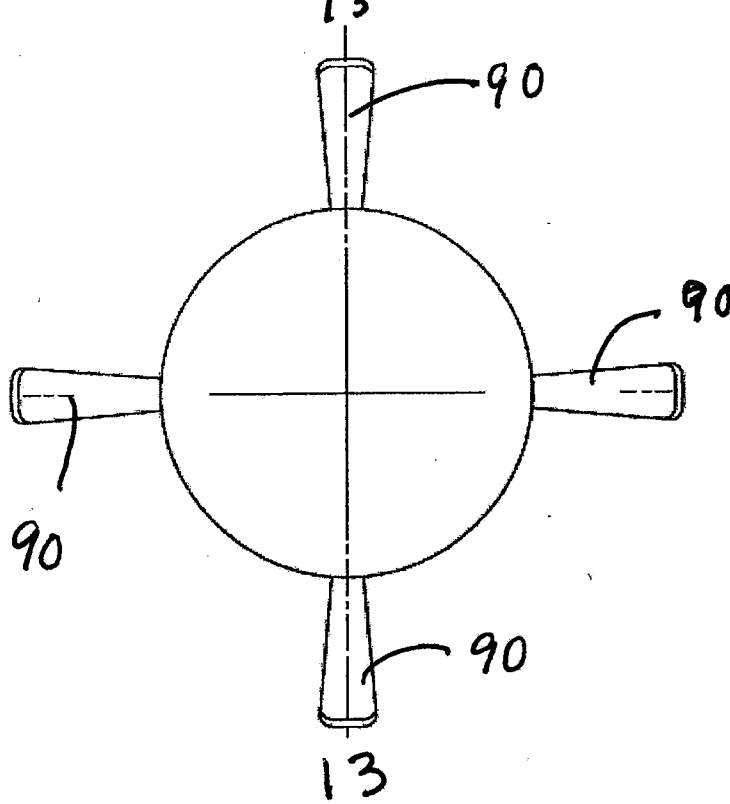

FIG. 12



11/18

FIG. 13

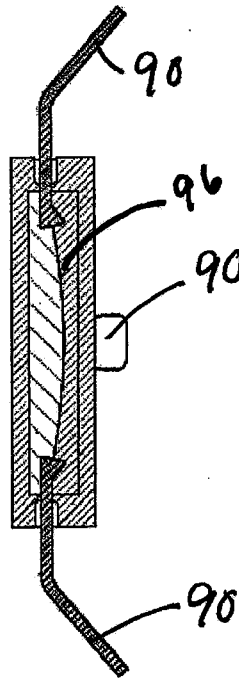
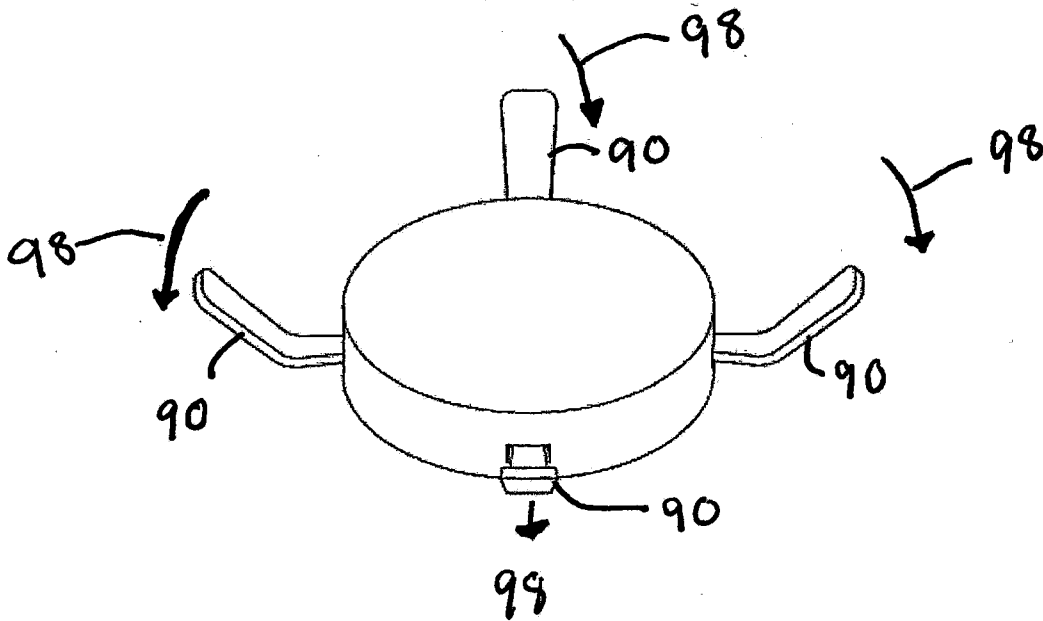

FIG. 14



12/18

FIG. 15

Accommodated state

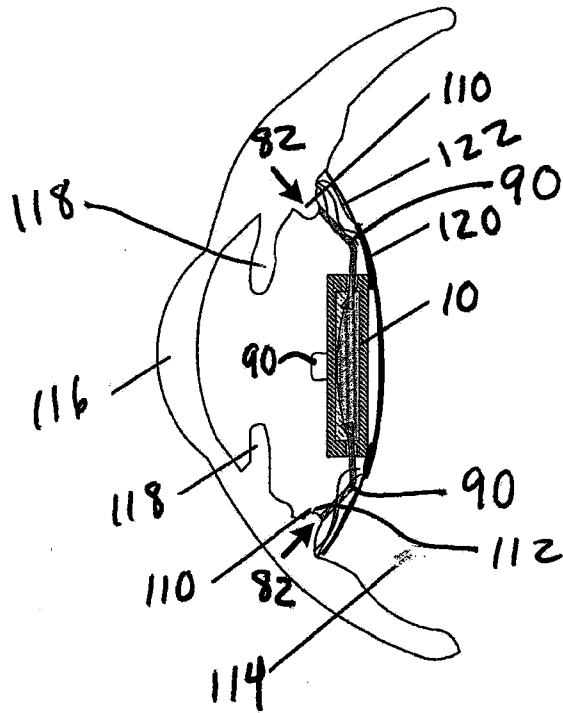

13/18

FIG. 16

Unaccommodated state

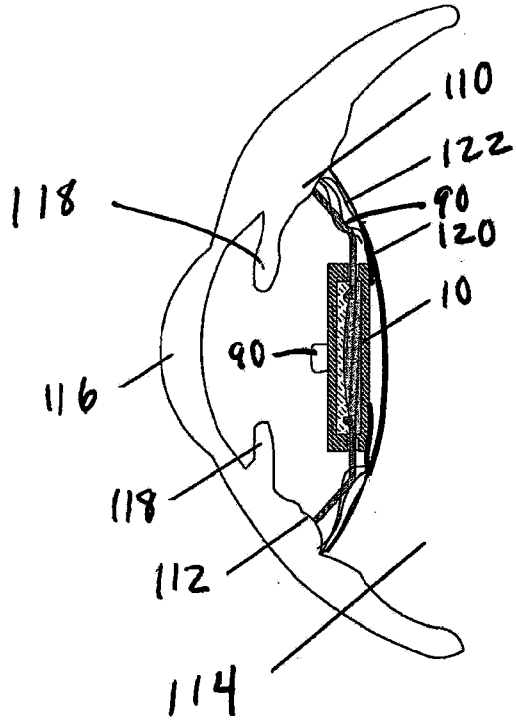
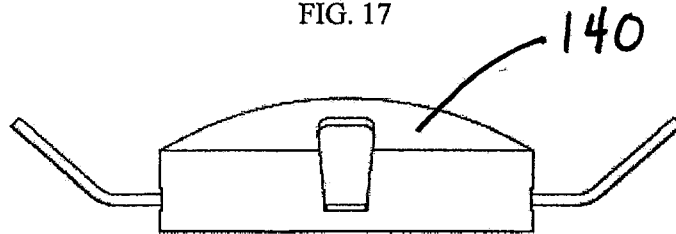
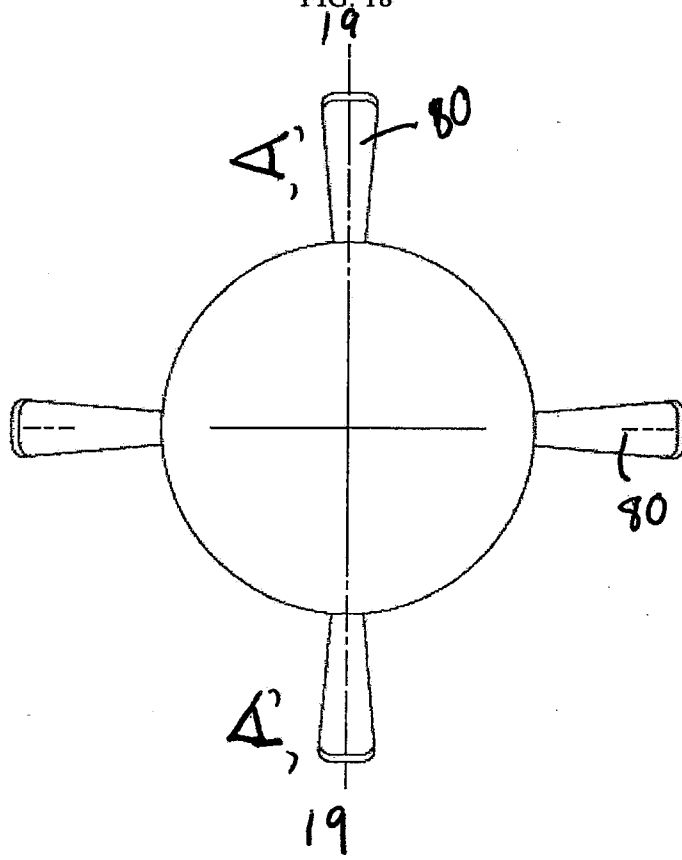

FIG. 17



14/18

FIG. 18



15/18

FIG. 19

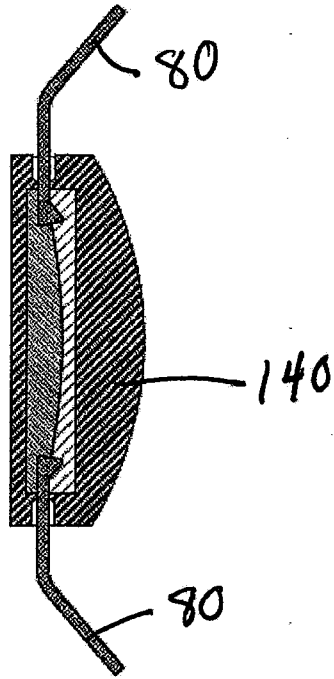

16/18

FIG. 20

Accommodated state

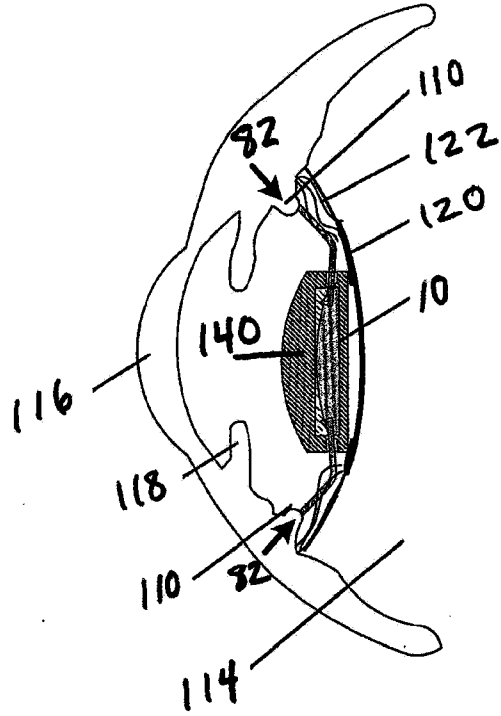

17/18

FIG. 21

Unaccommodated state

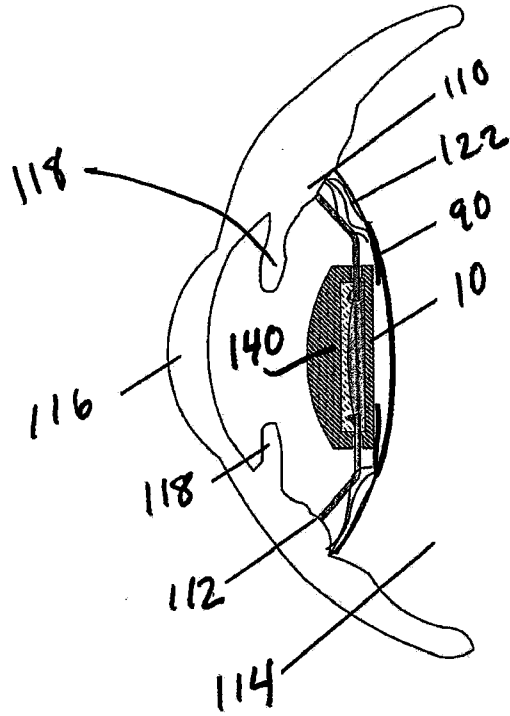
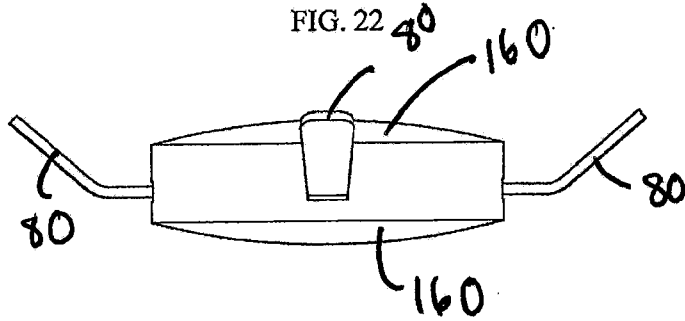

FIG. 22



18/18

FIG. 23

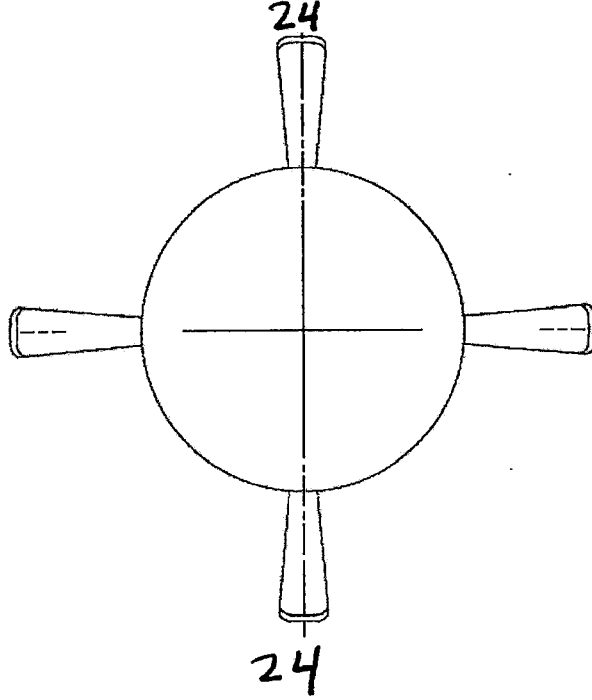
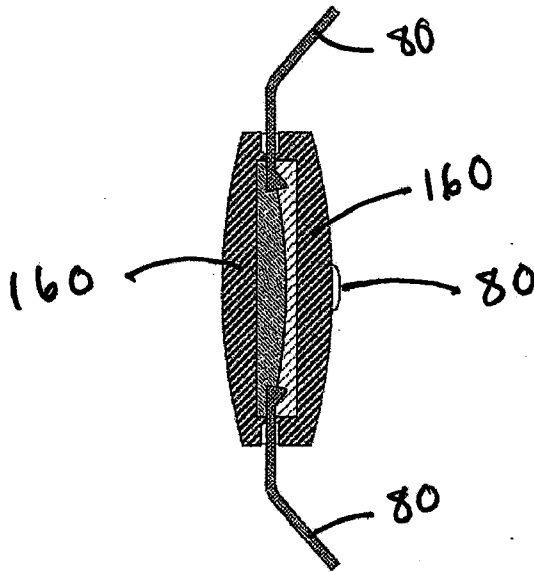

FIG. 24



A. CLASSIFICATION OF SUBJECT MATTER*A61F 2/16(2006.01)i*

According to International Patent Classification (IPC) or to both national classification and IPC

B. FIELDS SEARCHED

Minimum documentation searched (classification system followed by classification symbols)

IPC 8 A61F 2/16

Documentation searched other than minimum documentation to the extent that such documents are included in the fields searched

Electronic data base consulted during the international search (name of data base and, where practicable, search terms used)

eKIPASS, NCBI PubMed database, Delphion Research Intellectual Property Network database

C. DOCUMENTS CONSIDERED TO BE RELEVANT

Category*	Citation of document, with indication, where appropriate, of the relevant passages	Relevant to claim No.
X A	US 6,855,164 B2 (Glazier) Feb. 15, 2005 See the abstract; figure ; column 12, lines 27-48; claims	1 5 - 9
A	US 6,730,123 B1 (Klopotek) May 4, 2004 See the whole document.	1, 5 - 9
A	US 5,443,506 A (Garabet) Aug. 22, 1995 See the whole document.	1, 5 - 9
A	US 7,025,783 B2 (Brady et al.) Apr. 11, 2006 See the whole document.	1, 5 - 9
A	US 2004/0181279 A1 (Nun) Sep. 16, 2004 See the whole document.	1, 5 - 9

 Further documents are listed in the continuation of Box C. See patent family annex.

* Special categories of cited documents:

"A" document defining the general state of the art which is not considered to be of particular relevance

"E" earlier application or patent but published on or after the international filing date

"L" document which may throw doubts on priority claim(s) or which is cited to establish the publication date of citation or other special reason (as specified)

"O" document referring to an oral disclosure, use, exhibition or other means

"P" document published prior to the international filing date but later than the priority date claimed

"T" later document published after the international filing date or priority date and not in conflict with the application but cited to understand the principle or theory underlying the invention

"X" document of particular relevance; the claimed invention cannot be considered novel or cannot be considered to involve an inventive step when the document is taken alone

"Y" document of particular relevance; the claimed invention cannot be considered to involve an inventive step when the document is combined with one or more other such documents, such combination being obvious to a person skilled in the art

"&" document member of the same patent family

Date of the actual completion of the international search

26 JUNE 2008 (26.06.2008)

Date of mailing of the international search report

26 JUNE 2008 (26.06.2008)

Name and mailing address of the ISA/KR

Korean Intellectual Property Office
Government Complex-Daejeon, 139 Seonsa-ro, Seo-
gu, Daejeon 302-701, Republic of Korea

Facsimile No. 82-42-472-7140

Authorized officer

JEONG Eui Jun

Telephone No. 82-42-481-5549



Box No. II Observations where certain claims were found unsearchable (Continuation of item 2 of first sheet)

This international search report has not been established in respect of certain claims under Article 17(2)(a) for the following reasons:

1. Claims Nos.: 2-4 and 10-13
because they relate to subject matter not required to be searched by this Authority, namely:

Claims 2-4 and 10-13 pertain to methods for treatment of the human or animal body by therapy methods, and thus relate to a subject matter which this International Searching Authority is not required, under Article 17(2)(a)(i) of the PCT and Rule 39(iv) of the Regulations under the PCT, to search.

2. Claims Nos.:
because they relate to parts of the international application that do not comply with the prescribed requirements to such an extent that no meaningful international search can be carried out, specifically:

3. Claims Nos.:
because they are dependent claims and are not drafted in accordance with the second and third sentences of Rule 6.4(a).

Box No. III Observations where unity of invention is lacking (Continuation of item 3 of first sheet)

This International Searching Authority found multiple inventions in this international application, as follows:

1. As all required additional search fees were timely paid by the applicant, this international search report covers all searchable claims.
2. As all searchable claims could be searched without effort justifying an additional fee, this Authority did not invite payment of any additional fee.
3. As only some of the required additional search fees were timely paid by the applicant, this international search report covers only those claims for which fees were paid, specifically claims Nos.:
4. No required additional search fees were timely paid by the applicant. Consequently, this international search report is restricted to the invention first mentioned in the claims; it is covered by claims Nos.:

Remark on Protest

- The additional search fees were accompanied by the applicant's protest and, where applicable, the payment of a protest fee.
- The additional search fees were accompanied by the applicant's protest but the applicable protest fee was not paid within the time limit specified in the invitation.
- No protest accompanied the payment of additional search fees.

INTERNATIONAL SEARCH REPORT

Information on patent family members

International application No.

PCT/US2008/052933

Patent document cited in search report	Publication date	Patent family member(s)	Publication date
US 6855164 B2	15.02.2005	CA 2450371 A1	19.12.2002
		EP 1395203 A1	10.03.2004
		JP 2004-532697 T2	28.10.2004
		US 2003-0093149 A1	15.05.2003
		US 2005-071002 A1	31.03.2005
		US 2005-119739 A1	02.06.2005
		US 2007-067030 A1	22.03.2007
		US 66788S1	10.12.2002
		US 7229475 BB	12.06.2007
		DO 466788	10.12.2002
		WO 2002-100300 A1	19.12.2002
US 6730123 B1	04.05.2004	AU 2001-68649 A1	02.01.2002
		EP 1296617 A2	02.04.2003
		JP 2003-535651 T2	02.12.2003
		WO 2001-97742 A2	27.12.2001
US 5443506 A	22.08.1995	- NONE -	
US 7025783 B2	11.04.2006	US 2003-0135272 A1	17.07.2003
		US 2004-127984 A1	01.07.2004
		US 2006-161252 AA	20.07.2006
		US 2007-043437 A1	22.02.2007
		US 7150759 BB	19.12.2006
US 2004-0181279 A1	16.09.2004	AU 2002-326134 CA	03.03.2003
		AU 2002-326134 BB	26.04.2007
		CA 2471186 AA	27.02.2003
		EP 1420722 A1	26.05.2004
		IL 160484 A0	25.07.2004
		US 2007-185574 AA	09.08.2007
		US 7220279 BB	22.05.2007
		WO 2003-015669 A1	27.02.2003