

E. O. Scharlau,

Cork Machine.

No. 110,076.

Patented Dec. 13, 1870.

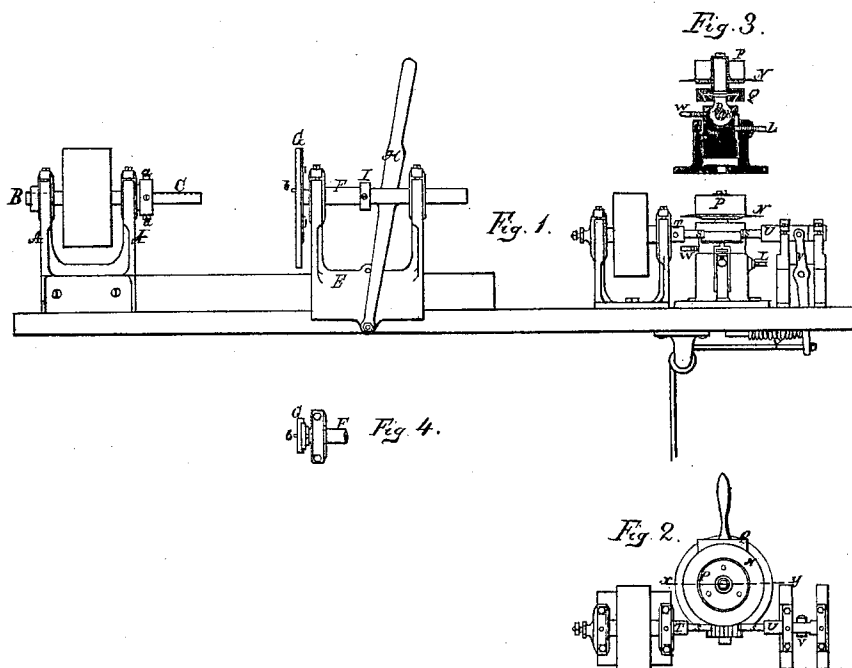

Witnesses:

Ch. Jacobs
C. Alexander

Inventor.

E. O. Scharlau

Per

C. Alexander

Atty.

United States Patent Office.

EILERT O. SCHARTAU, OF PHILADELPHIA, PENNSYLVANIA.

Letters Patent No. 110,076, dated December 13, 1870.

IMPROVEMENT IN CORK-MACHINES.

The Schedule referred to in these Letters Patent and making part of the same.

To all whom it may concern:

Be it known that I, EILERT O. SCHARTAU, of Philadelphia, in the county of Philadelphia and State of Pennsylvania, have invented certain new and useful Improvements in Cork-Cutting Machines; and I do hereby declare that the following is a full, clear, and exact description thereof, reference being had to the accompanying drawings and to the letters of reference marked thereon which form a part of this specification.

The nature of my invention consists in the construction and arrangement of a machine for cutting corks from strips already cut of the desired thickness.

In order to enable others skilled in the art to which my invention appertains to make and use the same, I will now proceed to describe its construction and operation, referring to the annexed drawings, in which—

Figure 1 is a side view of the entire machine;

Figure 2 is a plan view of the mechanism for cutting conical corks;

Figure 3 is a vertical section through line $x y$, fig. 2; and

Figure 4 is a plan view of the slide-rest G, fig. 1.

Unlike most kinds of wood, the material of which corks are made is uneven, cracked, and worm-eaten, hence the chance of success in manufacturing cork is lessened in proportion as the machinery is complicated with a view of cutting many corks at once.

The object of my improvement has therefore been of constructing a cork-machine that combines the precision and quickness of work derived from the use of machinery with the saving of materials, the avoiding of defects in the cork-wood, and also the facility of improving on the quality of the work by an immediate inclining of the circular knife.

For cutting cylindrical corks I have invented a steeled iron or brass tube.

This construction of the knife presents some marked advantages over the cylindrical knives now in use for cutting corks.

The cost of my steeled knives is reduced to one-third; the steel attached to the brass tube admits, in consideration of its shortness, of a perfect working and tempering; the steel may be used for cutting to the very last, while it is evident that the brass stock cannot undergo any considerable wear, even by a constant use of it for many years.

A represents the lathe-head, supporting a hollow mandrel, B.

To this latter is the stocked cylindrical knife C attached, the adjusting-screws $a a$ serving both to hold and center up the knife.

E represents the poppet-head, supporting a center-shaft, F, headed by a slide-rest, G, the whole moved backward and forward by the lever H.

A set-screw, I, regulates the motion of said lever.

The end of the strip of cork-wood is lightly pressed against a knob, b , upon the face of the slide-rest G,

and by a forward motion of the lever H the cork is cut and passes through the mandrel B, one cork pushing the other.

The knife C is, as above described, composed of an iron or brass tube with steel end, and may be exchanged for another of different size when it is desired to cut corks of larger or smaller diameter.

The slide-rest G has to be adjusted, up or down, to correspond with the knife used, so as to bring the knob b to the proper place.

The device supporting the poppet-head E is also adjustable, so as to bring it closer to or further from the knife, for different thicknesses of corks, and fastened by a set-screw at the desired point.

The corks having been cut cylindrical, if it is desired to make them conical, the tapering is done by a plain circular knife, N, which is attached to a pulley, P, said pulley and knife being mounted upon a slide-rest, Q, placed or attached to a knuckle-joint, R.

The combined motions of the slide-rest Q and knuckle-joint R permit the operator, while running the machine, to incline at will the knife N, either to the right or left, or toward the center, as the defects of the cork-wood may require.

The cylindrical cork is pressed between two centers S S, one attached to the mandrel T, carrying the cork, and the other simply turning round on its center in the connecting-mandrel U, which, by the action of the lever V, spiral spring Y, and a treadle, has a backward and forward motion, required for the holding of the cork, and its letting loose after having been cut.

When it is required that the knuckle-joint R shall have a permanent position, the set-screw W secures it firmly in place, and in order to limit and regulate the motion of said joint it is transversely by an axle, D.

The circular knife N may be raised and lowered at will, and adjusted by means of the screw L.

Having thus fully described my invention,

What I claim as new, and desire to secure by Letters Patent, is—

1. The circular knife N, provided with pulley P, and journaled upon slide Q, substantially in the manner and for the purpose described.

2. The combination of the poppet-head E, shaft F, slide-rest G, and lever H, all constructed and arranged to operate substantially as and for the purposes herein set forth.

3. The combination of the circular knife N and adjustable slide-rest Q, all constructed and arranged to operate substantially as and for the purpose herein set forth.

In testimony that I claim the foregoing as my own I affix my signature in presence of two witnesses.

EILERT O. SCHARTAU.

Witnesses:

C. ALEXANDER,
T. H. ALEXANDER.