

⑫

EUROPEAN PATENT SPECIFICATION

④⑤ Date of publication of the patent specification:
20.12.89

⑥① Int. Cl. 4: **B67D 1/00, B67D 1/08,**
F25D 31/00

②① Application number: **87200784.4**

②② Date of filing: **25.04.87**

⑤④ **Device for the storage and cooling of beer intended for supply to a tap.**

③⑩ Priority: **28.04.86 NL 8601082**

⑦③ Proprietor: **Ummels, Johannes Antoinetta Michael,**
Sparrenlaan 90, NL-5553 CZ Valkenswaard(NL)

④③ Date of publication of application:
04.11.87 Bulletin 87/45

⑦② Inventor: **Ummels, Johannes Antoinetta Michael,**
Sparrenlaan 90, NL-5553 CZ Valkenswaard(NL)

④⑤ Publication of the grant of the patent:
20.12.89 Bulletin 89/51

⑦④ Representative: **Timmermans, Anthonius C.Th., Ir. et al,**
European Patent Attorneys Octrooibureau Zuid P.O.
Box 2287, NL-5600 CG Eindhoven(NL)

⑥④ Designated Contracting States:
AT BE CH DE ES FR GB IT LI LU NL SE

⑥⑥ References cited:
WO-A-86/00064
FR-A- 1 532 368
GB-A- 2 145 395
US-A- 2 214 344
US-A- 2 342 299
US-A- 2 618 938
US-A- 3 809 292

EP 0 244 031 B1

Note: Within nine months from the publication of the mention of the grant of the European patent, any person may give notice to the European Patent Office of opposition to the European patent granted. Notice of opposition shall be filed in a written reasoned statement. It shall not be deemed to have been filed until the opposition fee has been paid (Art. 99(1) European patent convention).

Description

The invention relates to a device for the storage and cooling of beer and the supply thereof to a tap via a water cooled beer pipe (python), which device further comprises at least one storage container and a cooling element arranged parallel thereto, consisting of a jacket with a cooling water inlet and an outlet, which jacket accommodates a beer pipe in the shape of a brake coil and a heat exchanger containing a pipe for passing a cooling medium e.g. freon. The invention also relates to a tap installation provided with such a device.

In the international application WO-8 600 064 a tap device for beer is described comprising at least one tap and one storage container which are mutually connected by a water cooled beer pipe. The storage container is thereby arranged in a closed cooling room and is cooled by a hollow closed cooling element which is in good heat exchanging communication with the outer wall of the storage container. Located in this cooling element are a beer pipe, at least partially constructed as a so-called brake coil as well as a pipe through which a cooling medium, e.g. freon, flows. Water flows through the cooling element, cooling the contents of the storage container as a result of contact with the cooling medium pipe on the one hand and with the storage container on the other hand. The cooling element may have various shapes but according to a special embodiment of this known device use is made of the space which is present between two storage tanks located side by side. Said space is closed and then functions as a hollow closed cooling element in which the above-mentioned pipes are present.

Although very good results could be attained with the installation described above its construction was only wise financially for catering businesses consuming large quantities of beer. Hereby one should have in mind tanks with a capacity of 500 to 1000 litres. For smaller catering businesses a storage container of 150 to 300 litres will generally be sufficient. It is also desirable thereby, however, that two, or sometimes more, of such storage containers are used in order not to interrupt tapping when a new supply of beer is being supplied to an empty storage container. A device according to the invention is specially suitable for such smaller catering businesses.

The invention is based on the fact that with smaller installations the cooling element does not have to be in direct contact with the storage container and that the storage container or the storage containers need not be arranged in a closed cooling room provided the necessary provisions for keeping the beer cool are made such as will be further described hereinafter, in particular in the characteristic part of the claims. An essential difference described above is furthermore that the water flowing round and thus cooling the beer coils is cooled itself by a heat exchanger located outside the room in which the beer coils are arranged. Because with a device according to the invention there is no direct contact between the storage container (the storage containers) and the cooling element and the beer

has yet to be cooled adequately further provisions are necessary and according to the invention a cooling space is provided at the bottom side of each storage container for that purpose, water flowing through said cooling space adjoining the bottom side of the storage container. Furthermore the wall of the storage container, as well as the bottom side of said cooling room, are provided with a heat insulating layer e.g. of polyurethane foam. Also the entire cooling element is provided with a thick heat insulating layer which may also consist of polyurethane foam.

The brake coils in the cooling element are on the one hand connected to the beer pipe in the python and on the other hand with an outlet at the bottom side of the storage container.

As will be explained hereinafter a cooling circuit is present, through which water is pumped, said cooling circuit comprising at least the cooling bottom of the storage container, the inner room of the cooling element in which the brake coils are arranged and a room relatively narrowly surrounding the pipe in which the cooling medium, e.g. freon, flows. Also the cooling circuit of the python may be advantageously incorporated in the entire circuit. In that case only one cooling water pump is needed.

A device according to the invention is characterized in that the storage container and the cooling element are insulated individually, that the storage container is arranged vertically while it has a cooling space at its bottom side, which is coupled with the outlet, and that the cooling element has an inner room with the cooling water inlet at the bottom side and a cooling water outlet at the upper side coupled to the outlet via the heat exchanger surrounding the pipe.

It is observed at this place, that a beverage barrel having a cooling space at its bottom side is known per se from US-A 2 214 344.

Furthermore it is observed that US-A 2 618 938 and US-A 2 342 299 disclose cooling arrangements with advanced cooling devices at the circumference respectively at the inside of the beer containers in order mainly to cool the beer in the container only.

With a device according to the invention having two containers placed side by side a compact and effective arrangement is obtained when the cooling element is located between the two containers. The beer pipe which leaves the cooling element at the bottom side may thereby be advantageously provided with a rotatable coupling and a swivelling arm with which the coupling to either of the two storage containers can be effected. In this manner it will be possible to take the one container into use e.g. when the other container is being filled so that tapping is not interrupted.

The heat exchanger, preferably U-shaped, which consists of an inner pipe surrounded by a jacket, as already described above, preferably comprises elements amplifying the transfer of heat, said e.g. filliform elements, being fixed to the inner pipe. The cooling water flows along the inner pipe and the heat transferring elements and is very well cooled as a result.

The cooling of the bottoms of the storage containers may take place e.g. by providing a cooling coil against the bottom side. According to a special embodiment of the present invention said cooling coil is formed between two parallel plates in which a partition is present forming a spiral through-flow pipe therein. One of said plates may be formed by the bottom side of the storage container itself.

If there are more brake coils present in the cooling element advantageous use is made of a distribution pipe which is located inside the cooling element and which may be centrally connected to the storage container(s); with this construction it will be possible to provide several taps with beer from one storage container via various brake coils. Preferably taps are provided in the connections of the distribution pipe with the brake coils, which taps can be operated outside the cooling element. Said taps may also be constructed as threeway taps which makes it possible to disengage one brake coil entirely and connect it to a flushing pipe; it will be possible then to flush the entire pipe from the tap up to and including the brake coil.

The invention will be explained now with reference to a drawing, in which:

fig 1 illustrates the general arrangement of a device according to the invention with two storage containers;

fig 2 provides a longitudinal section of a cooling element with the heat exchanger present therein;

fig 3 provides a side view of the heat exchanger according to fig 2;

fig 4 provides a top view of a cooling space under a storage container;

fig 5 provides a diagrammatic cross-section of a cooling element comprising a distribution pipe for several brake coils.

In fig 1 reference numbers 1 and 2 indicate the two storage containers for the beer and number 3 indicates the cooling element located therebetween. Said cooling element is provided at its bottom side with a spout 4, said spout 4 being in communication with a swivelling arm 6 in which a non-return valve is provided. Said swivelling arm 6 may be put into communication either with tank 1 via the tap 7 or with tank 2 via the tap 8. Via said taps 7 and 8 it will also be possible to fill the tanks with beer, e.g. from a tank lorry. In the tanks there may be present, in a manner known by itself, plastic bags in which the beer is stored. By means of pressure via the taps 9 and 10 the beer can be forced from the storage containers 1 and 2 into the brake coil or coils in the cooling element 3. At the upper side the beer flows out of the cooling element to the python 11 which ends at the tap 12. Said python, being cooled by water, may have a construction as illustrated in the abovementioned international application WO-8 600 064. At the bottom side the storage containers 1 and 2 have a closed space 13, 14 respectively in which cooling water circulates via the inlets 15 and the outlets 16.

Fig 2 diagrammatically illustrates a longitudinal section of the cooling element 3. Said element has an outer wall 17, e.g. of aluminium, in which the inner

pipe is located. Arranged in the interior of said pipe 18 is the beer pipe, in the shape of a brake coil 19. The beer flows into the brake coil at the bottom side at 20 and is supplied to the beer pipe in the python at 21. Water flows through the inner pipe 18, said water flowing in at 22 and flowing out of the room 18 at 23. At 23 the water then flows to the heat exchanger which consists of an outer jacket 24 and an inner pipe 25 through which a cooling medium, e.g. freon, flows. The cooling water flows out of the heat exchanger at 26. From there the cooling water is led to the inlets 15 (fig 1) of the cooling bottoms of the storage containers. Between the inner pipe 25 and the jacket 24 there are provided elements 27, in wire form here, amplifying the transfer of heat. Said elements are fixed to the pipe 25. The wall 17 is filled with insulating material, e.g. polyurethane foam. The supply of cooling water takes place at 22 as indicated above. Said cooling water can come directly from a pump and be led to the cooling bottoms of the storage containers at 26. Return to the pump is then effected from said cooling bottoms of the storage containers via the outlets 16 (fig 1). It is also possible, however, to send the cooling water from the pump through the cooling water jacket of the python first and from there let it follow the same route via 22 as described above. Under all circumstances, however, cooling takes place according to the reflux principle.

Fig 3 diagrammatically illustrates, in side view, the heat exchanger of fig 2 again. From this figure it is apparent that the heat exchanger is U-shaped. The reference numerals correspond with those of fig 2.

Fig 4 diagrammatically illustrates a special embodiment of a cooling space under a storage container. Said room consists of two more or less parallel plates, one of which may be the bottom of the container itself, and is divided by the partition 30 in such a manner that a spiral channel is formed from the water inlet 15 to the water outlet 16. 31 indicates the supply pipe which may be put into communication with the cooling element, e.g. as illustrated in fig 1.

Fig 5 diagrammatically illustrates a cooling element suitable for supplying two taps. This cooling element essentially corresponds with the cooling element illustrated in fig 2. The reference numbers therefore correspond with the reference numbers of said fig 2. In the inner pipe 18, however, not one brake coil is present as indicated by 19 in fig 2, but two brake coils, viz. 32 and 33. These are indicated by single lines for the sake of simplicity. Located beside the inner pipe 18 is the distribution pipe 34 to which the brake coils 32 and 33 are connected. Said distribution pipe may be connected to a storage container at 20 and drives the beer, via the valves 35, 36 respectively, to the brake coils 32, 33 respectively. Said valves can be operated outside the cooling element.

The embodiments illustrated in the figure are only meant as examples; the invention is only restricted by the claims following hereinafter.

Claims

1. Device for the storage and the cooling of beer and the supply thereof to a tap (12) via a water cooled beer pipe (11) (python), which device further comprises at least one storage container (1) and a cooling element (3) arranged parallel thereto, consisting of a jacket (24) with a cooling water inlet (22) and an outlet (26), which jacket (24) accommodates a beer pipe in the shape of a brake coil (19) and a heat exchanger containing a pipe (25) for passing a cooling medium e.g. freon, characterized in that the storage container (1) and the cooling element (3) are insulated individually, that the storage container (1) is arranged vertically while it has a cooling space (13) at its bottom side, which is coupled with the outlet (26), and that the cooling element (3) has an inner room (18) with the cooling water inlet (22) at the bottom side and a cooling water outlet (23) at the upper side coupled to the outlet (26) via the heat exchanger surrounding the pipe (25).

2. Device according to claim 1, characterized in that the device comprises two storage containers (1, 2) arranged substantially parallel and that the cooling element (3) is arranged between the two containers (1, 2).

3. Device according to claim 1 or 2, characterized in that the cooling water circuit of the beer pipe (11) and the cooling water circuit (22, 26) of the cooling element (3) form a continuous cooling water circuit.

4. Device according to claim 1, 2 or 3, characterized in that the pipe (25) of the heat exchanger is provided at the outside, inside the jacket space, with surface enlarging, e.g. filiform heat transfer elements (27).

5. Device according to claims 1, 2, 3 or 4, characterized in that the heat exchanger is U-shaped.

6. Device according to claims 1, 2, 3, 4 or 5, characterized in that the cooling space at the bottom of the storage container(s) (1, 2) is a double-walled space which is spirally divided by a division plate (30).

7. Device according to claims 1, 2, 3, 4, 5 or 6, having at least two brake coils (32, 33) in the cooling element (3), characterized in that a disturbing pipe (34) is present in the cooling element (3) which can be centrally connected to the storage containers (1, 2) and is in communication with the brake coils (32, 33).

8. Device according to claim 7, characterized in that valves (35, 36), which can be operated separately outside the cooling element (3), are present in the connections of the distributing pipe (34) with the brake coils (32, 33).

9. Device according to claim 2, 3, 4, 5, 6, 7 or 8, characterized in that the beer pipe at the bottom side (20) of the cooling element (3) is provided with a rotatable coupling and a swivelling arm (6) to which either of the two storage containers (1, 2) can be connected.

10. Device according to claims 1, 2, 3, 4, 5, 6, 7, 8 or 9, characterized in that the storage container(s) (1, 2) has (have) a capacity of 150 - 300 litres.

11. Tapping installation for beer comprising at least one tap (12) and a water cooled beer pipe

(python) (11), characterized in that the beer pipe (11) is connected to a device according to any one or more of the preceding claims.

5 Patentansprüche

1. Vorrichtung für die Lagerung und Kühlung von Bier und für die Zufuhr von Bier zu einem Zapfhahn (12) über eine wassergekühlte Bierleitung (Python) (11), welche Vorrichtung weiter wenigstens einen Vorratsbehälter (1) und ein parallel damit angeordnetes Kühlelement (3) enthält, das aus einem Mantel (24) mit einem Einlaß (22) und einem Auslaß (26) für Kühlwasser besteht, in welchem Mantel (24) sich eine Bierleitung in Form einer Bremsspirale (19) befindet sowie ein Wärmetauscher mit einem Rohr (25) zur Durchführung eines Kühlmittels, beispielsweise Freon, dadurch gekennzeichnet, daß der Vorratsbehälter (1) und das Kühlelement (3) gesondert isoliert sind und daß der Vorratsbehälter (1) senkrecht angeordnet ist und an seiner Unterseite einen Kühlraum (13) hat, der mit dem Auslaß (26) verbunden ist, und wobei das Kühlelement (3) eine innere Kammer (18) hat mit dem Kühlwassereinlaß (22) an der Unterseite und einem Kühlwasserauslaß (23) an der Oberseite, der mit dem Auslaß (26) über den Wärmetauscher gekoppelt ist, der das Rohr (25) umgibt.

2. Vorrichtung nach Anspruch 1, dadurch gekennzeichnet, daß die Vorrichtung zwei praktisch parallel angeordnete Vorratsbehälter (1, 2) hat und das Kühlelement (3) zwischen den beiden Behältern (1, 2) angeordnet ist.

3. Vorrichtung nach Anspruch 1 oder 2, dadurch gekennzeichnet, daß der Kühlwasserkreis der Bierleitung (11) und der Kühlwasserkreis (22, 26) des Kühlelements (3) einen durchgehenden Kühlwasserkreis bilden.

4. Vorrichtung nach Anspruch 1, 2 oder 3, dadurch gekennzeichnet, daß das Rohr (25) des Wärmetauschers an der Außenseite, daß heißt in dem Mantelraum, mit oberflächenvergrößernden, zum Beispiel drahtförmigen, Wärme-Übertragungselementen (27) ausgestattet ist.

5. Vorrichtung nach Anspruch 1, 2, 3 oder 4, dadurch gekennzeichnet, daß der Wärmetauscher U-förmig ist.

6. Vorrichtung nach Anspruch 1, 2, 3, 4 oder 5, dadurch gekennzeichnet, daß der Kühlraum in dem Boden des/der Vorratsbehälter(s) (1, 2) ein doppelwandiger Raum ist, der mit einer Quertrennwand (30) spiralförmig geteilt ist.

7. Vorrichtung nach Anspruch 1, 2, 3, 4, 5 oder 6, mit wenigstens zwei Bremsspiralen (32, 33) in dem Kühlelement (3), dadurch gekennzeichnet, daß sich in dem Kühlelement (3) ein Verteilerrohr (34) befindet, das zentral an den/die Vorratsbehälter (1, 2) angeschlossen werden kann und mit den Bremsspiralen (32, 33) in Verbindung steht.

8. Vorrichtung nach Anspruch 7, dadurch gekennzeichnet, daß sich in den Verbindungen des Verteilerrohrs (34) mit den Bremsspiralen (32, 33) separat außerhalb des Kühlelements (3) bedienbare Hähne (35, 36) befinden.

9. Vorrichtung nach Anspruch 2, 3, 4, 5, 6, 7 oder 8, dadurch gekennzeichnet, daß die Bierlei-

tion an der Unterseite (20) des Kühlelements (3), mit einer drehbaren Kupplung und einem Schwenkarm (6) versehen ist, mit denen einer der beiden Vorratsbehälter (1, 2) angeschaltet werden kann.

10. Vorrichtung nach Anspruch 1, 2, 3, 4, 5, 6, 7, 8 oder 9, dadurch gekennzeichnet, daß der/die Vorratsbehälter (1, 2) einen Inhalt von 150 – 300 Liter hat/haben.

11. Zapfanlage für Bier, die wenigstens einen Zapfhahn (12) und eine wassergekühlte Bierleitung (Python) (11) umfaßt, dadurch gekennzeichnet, daß die Bierleitung (11) mit einer Vorrichtung nach einem der mehreren der vorstehenden Ansprüche verbunden ist.

Revendications

1. Dispositif pour le stockage et le refroidissement de la bière, et son transfert à un robinet de soutirage (12) par l'intermédiaire d'une conduite de bière refroidie par eau (python) (11), dispositif qui comporte en outre au moins un réservoir d'approvisionnement (1) et, disposé parallèlement à celui-ci, un élément de refroidissement (3) constitué par une chemise (24) avec une entrée (22) et une sortie (26) pour l'eau de refroidissement, chemise (24) dans laquelle se trouve une conduite de bière sous forme d'un serpentín de ralentissement (19) ainsi qu'un échangeur de chaleur avec un tuyau (25) pour le passage d'un fluide réfrigérant, par exemple du fréon, avec la caractéristique que le réservoir d'approvisionnement (1) et l'élément de refroidissement (3) sont isolés séparément et que le réservoir d'approvisionnement (1) est disposé verticalement et possède à sa partie inférieure une chambre de refroidissement (13) qui est raccordée avec la sortie (26), tandis que l'élément de refroidissement (3) possède une chambre intérieure (18) avec, à la partie inférieure, l'entrée d'eau de refroidissement (22) et, à la partie supérieure, une sortie d'eau de refroidissement (23) qui est raccordée à la sortie (26) par l'intermédiaire de l'échangeur de chaleur entourant le tuyau (25).

2. Dispositif selon la revendication 1, avec la caractéristique qu'il comporte deux réservoirs d'approvisionnement (1, 2) placés pratiquement dans des positions parallèles, et que l'élément de refroidissement (3) est située entre les deux réservoirs (1, 2).

3. Dispositif selon les revendications 1 ou 2, avec la caractéristique que le circuit d'eau de refroidissement de la conduite de bière (11) et le circuit d'eau de refroidissement (22, 26) de l'élément de refroidissement (3) forment un circuit d'eau de refroidissement ininterrompu.

4. Dispositif selon les revendications 1, 2 ou 3, avec la caractéristique que, dans sa partie extérieure, c'est-à-dire dans le vide de la chemise, le tuyau (25) de l'échangeur de chaleur est pourvu d'un élément de transfert de chaleur (27) accroissant la surface, par exemple un élément filiforme.

5. Dispositif selon les revendications 1, 2, 3 ou 4, avec la caractéristique que l'échangeur de chaleur est en forme-U.

6. Dispositif selon les revendications 1, 2, 3, 4 ou 5, avec la caractéristique que la chambre de refroidissement dans le fond du réservoir (des réservoirs) d'approvisionnement (1, 2) est un espace à double paroi qui est divisé par une cloison transversale en spirale (30).

7. Dispositif selon les revendications 1, 2, 3, 4, 5 ou 6 avec au moins deux serpentins de ralentissement (32, 33) dans l'élément de refroidissement (3), avec la caractéristique que, dans l'élément de refroidissement (3), il y a un tuyau de répartition (34) qui peut être raccordé centralement au réservoir (aux réservoirs) d'approvisionnement (1, 2), et se trouve en communication avec les serpentins de ralentissement (32, 33).

8. Dispositif selon la revendication 7, avec la caractéristique que, dans les communications du tuyau de répartition (34) avec les serpentins de ralentissement (32, 33), il y a des robinets (35, 36), actionnables séparément de l'extérieur de l'élément de refroidissement (3).

9. Dispositif selon les revendications 2, 3, 4, 5, 6, 7 ou 8, avec la caractéristique que la conduite de bière, à la partie inférieure (20) de l'élément de refroidissement (3), est équipée d'un accouplement rotatif et d'un bras pivotant (6) grâce auxquels on peut connecter l'un des deux réservoirs d'approvisionnement (1, 2).

10. Dispositif selon les revendications 1, 2, 3, 4, 5, 6, 7, 8 ou 9, avec la caractéristique que le réservoir (les réservoirs) d'approvisionnement (1, 2) a (ont) une contenance de 150 – 300 litres.

11. Installation pour la bière comportant au moins un robinet de soutirage (12) et une conduite de bière refroidie par l'eau (python) (11), avec la caractéristique que la conduite de bière (11) est reliée à un dispositif selon une ou plusieurs des revendications qui précèdent.

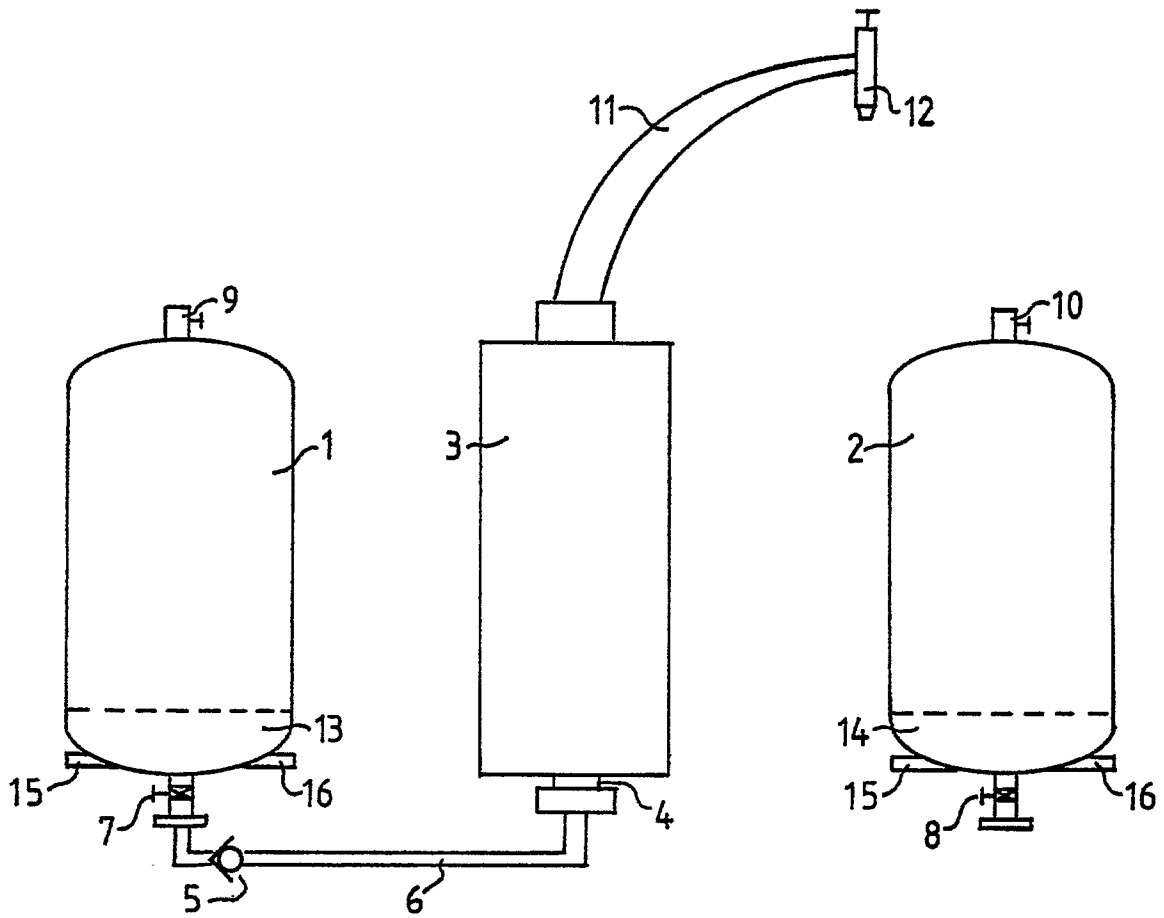

FIG. 1

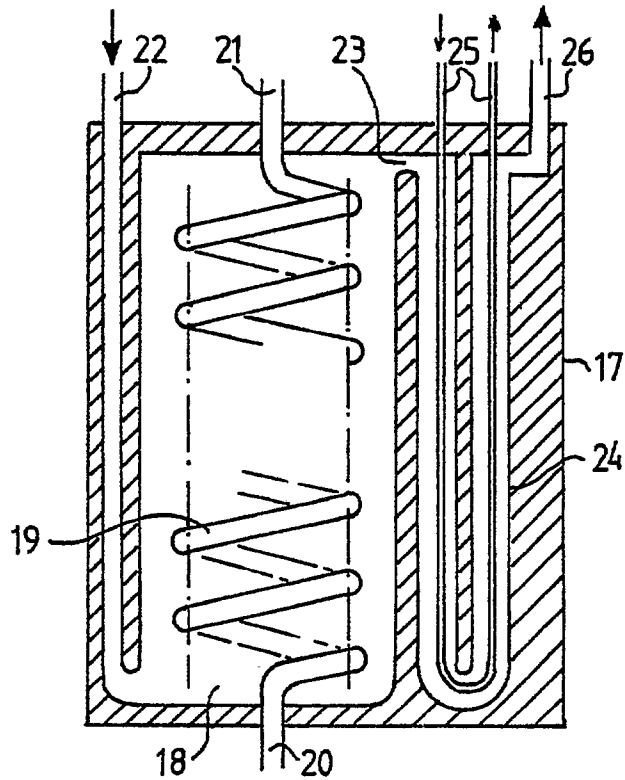

FIG. 2

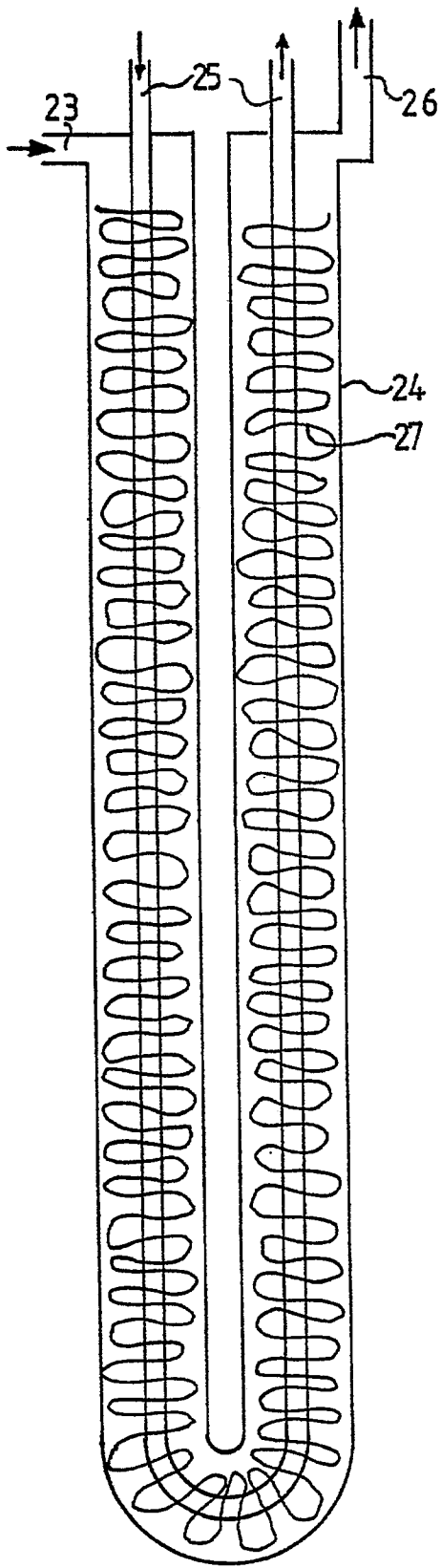

FIG. 3

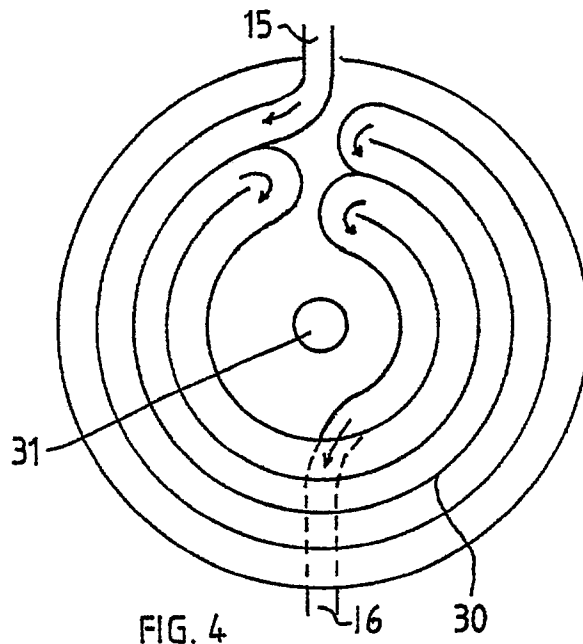

FIG. 4

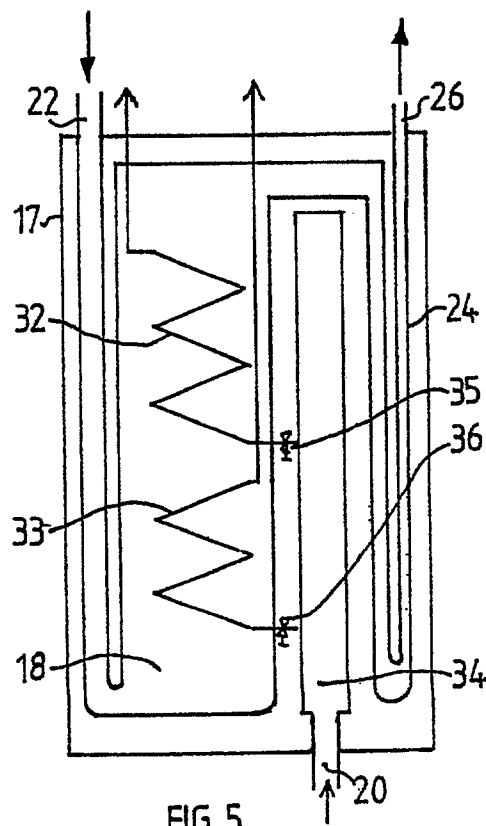

FIG. 5