

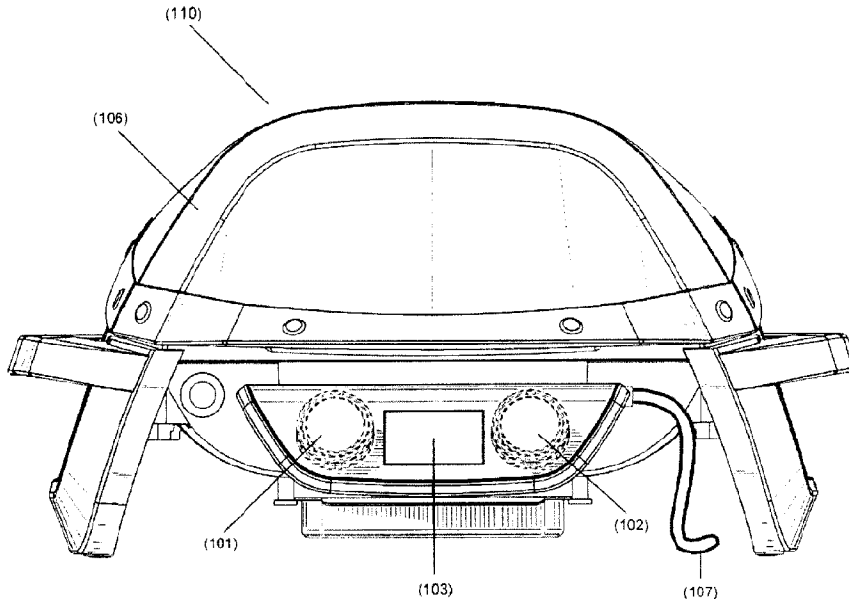

(22) Date de dépôt/Filing Date: 2017/06/23
(41) Mise à la disp. pub./Open to Public Insp.: 2018/01/01
(45) Date de délivrance/Issue Date: 2021/12/14
(30) Priorité/Priority: 2016/07/01 (US15/200,759)

(51) Cl.Int./Int.Cl. *H02M 11/00* (2006.01),
A47J 37/06 (2006.01), *A47J 37/07* (2006.01),
F24C 7/08 (2006.01), *H02J 3/00* (2006.01)
(72) Inventeurs/Inventors:
KNAPPENBERGER, ERIC, US;
ZULETA, JULIO C., US;
LERCH, MATTHEW, US;
EMMERICH, JEFFERY C., US
(73) Propriétaire/Owner:
WEBER-STEPHEN PRODUCTS LLC, US
(74) Agent: FINLAYSON & SINGLEHURST

(54) Titre : ALIMENTATION NUMERIQUE
(54) Title: DIGITAL POWER SUPPLY



(57) **Abrégé/Abstract:**

Provided is an apparatus and method for a digital power supply that can provide independent power control, and control variable power, for two or more electrical loads. Disclosed embodiments may reduce the magnitude of harmonic currents and for flicker introduced into a power system. Embodiments include a microprocessor that delivers power to electric loads using phase-controlled AC current. The microprocessor may calculate a power array corresponding to a requested power for each electric load. Logic is provided for populating the power array in a pattern that reduces the magnitude of harmonic currents and flicker.

Abstract

Provided is an apparatus and method for a digital power supply that can provide independent power control, and control variable power, for two or more electrical loads. Disclosed embodiments may reduce the magnitude of harmonic currents and/or flicker introduced into a power system. Embodiments include a microprocessor that delivers power to electric loads using phase-controlled AC current. The microprocessor may calculate a power array corresponding to a requested power for each electric load. Logic is provided for populating the power array in a pattern that reduces the magnitude of harmonic currents and flicker.

DIGITAL POWER SUPPLY

Field of the Invention

The present inventions relate to a digital power supply for independently controlling two or more high-powered loads with reduced harmonic and flicker
5 introduction. In a non-limiting embodiment, a digital power supply may be used in an electric grill to independently control two or more heating elements while reducing harmonics and flicker introduced to the power system.

Background of the Inventions

There is an increasing desire for a power supply that can independently control
10 two or more high-powered loads using an AC wall outlet while introducing a reduced amount of harmonics and/or flicker into the power grid. The urban population is increasing, and with it there is an increasing desire for high powered loads that can be plugged into an AC wall outlet. By way of example, urban dwellers live in apartment or condominium buildings where they would like to use a grill. Because of smoke, gas, or
15 other concerns, use of typical charcoal or gas grills may not be permitted or desirable.

There are a number of available electric cooking devices, such as the George Foreman Plate Grill (and similar devices), Panini presses, electric griddles and the like. However, these prior art devices generally do not deliver variable power. Moreover, these prior art electric cooking devices typically cannot generate enough power to match
20 a gas or electric grill.

Some prior art devices may use variable resistors in series with electric loads to control an amount of power delivered to the load. For example, as the resistance of a variable resistor increases, the variable resistor restricts power from being delivered to an

electric load. The use of variable resistors to control power delivery to electric loads is well known. But variable resistors come with disadvantages. For example, disadvantages may include the introduction of harmonics onto the electrical system, which translates to electromagnetic emissions that can create interference and other unpredictable
5 electromagnetic fields. Moreover, variable resistors may be inefficient because they burn a lot of power.

Other prior art devices may use a bi-metal thermometer which opens and closes to control power delivery. Disadvantages of using a bi-metal thermometer include the fact that it allows for less discrete (i.e., less precise) control over power delivered and is
10 usually associated with a relatively long lag in response time. A long lag time causes a negative cooking experience because it leads to poor control over temperature. Moreover, a long lag time is disadvantageous because long on/off duty cycles are known to shorten the life span of a heating element

Some devices may use half-wave control techniques to deliver power. For
15 example, U.S. Patent 6,772,475, titled "Heating Control System Which Minimizes AC Power Line Voltage Fluctuations," discloses half wave AC control devices to control delivery of AC current. This control method is associated with significant disadvantages because it delivers power only in stages, not in a continuous range from 0-100%. By contrast, embodiments of the present invention allow continuous variable power delivery.

20 Yet other prior art devices may include a digital control for limiting the in-rush of electric current when an electric load is turned on. For example, U.S. Patent 6,111,230, titled "Method and apparatus for supplying AC power while meeting the European flicker

and harmonic requirements,” describes a method for limiting the in-rush of current to a printing device when it is first turned on. However, the disclosed devices do not provide for independently controlling multiple electric loads, much less for reducing harmonic currents and flicker while independently controlling multiple loads.

5 Thus, there is a need for a digital power supply that can independently control two or more electric loads while introducing only reduced harmonic and flicker interference to the power system.

Brief Summary of the Inventions

10 The present inventions overcome many of the deficiencies of known power supplies and provide new features and advantages for devices such as electric grills. For example, embodiments of the present invention provide digital power controls that can deliver more precise amounts of power to electric loads. Moreover, embodiments of the present invention allow a plurality of electric loads to be controlled independently. Yet further embodiments of the present invention reduce the harmonic currents and flicker
15 that may result from plugging a power supply into a wall outlet.

 In accordance with a preferred embodiment of the present invention, a method of delivering power is provided. The method may include the steps of using one or more user input devices to select a first and second power setting for a first and second heating element, respectively; electronically communicating the power settings to a
20 microprocessor and using the microprocessor to calculate a total amount of power requested; using the microprocessor to populate a first and second power array corresponding to the first and second heating element, respectively; using the

microprocessor to calculate a first and second phase angle array corresponding to the first and second power array; causing the microprocessor to receive a zero crossing signal from a zero crossing detection unit; and for a first time period, delivering a phase-controlled AC wave pattern represented by the first phase angle array to the first heating element and delivering a phase-controlled AC wave pattern represented by the second phase angle array to the second heating element. Additional embodiments of the inventions comprise the step of, for a second time period, delivering a phase-controlled AC wave pattern represented by the first phase angle array to the second heating element and delivering a phase controlled AC wave pattern represented by the second phase angle array to the first heating element.

Further, each power array may contain four cells. Additionally, the step of using the microprocessor to populate a first and second power array may further comprise the steps of populating the first cell of the first power array with the same value as the third cell of the first power array; populating the second cell of the first power array with the same value as the fourth cell of the first power array; populating the first cell of the second power array with the same value as the third cell of the second power array; and populating the second cell of the second power array with the same value as the fourth cell of the second power array.

In embodiments of the inventions, each cell of each power array represents a power percentage and ranges from $0 \leq x \leq 1.0$. Every alternate cell in the first power array may be populated with a "0" or a "1". Moreover, every alternate cell in the second power array may be populated with a "0" or a "1". In some embodiments of the inventions, the first and second phase angle arrays are calculated using the

microprocessor to apply the equation $\text{angle} = \arccos(2x - 1)$ to the first and second power array, respectively. In further embodiments, the first time period is calculated as a ratio of the first power setting to the total amount of power requested and the second time period is calculated as a ratio of the second power setting to the total amount of power requested. Further, embodiments may include the step of activating a triac connected to a heating element.

Also provided are embodiments of a digital power supply, having a first and second user input; a first and second triac connected to a voltage line; a first and second triac driver respectively in communication with the first and second triac; a microprocessor in communication with the first and second triac drivers and in communication with the first and second user input; wherein the microprocessor is specifically configured to calculate a total power requested by the first and second user inputs and to populate a first and second power array based on the total power requested; and wherein the microprocessor is specifically configured to calculate a first and second array of phase angles based on the respective values of the first and second power array.

In embodiments of the invention the first and second power array each have four cells. The microprocessor may be specifically configured to populate at least one power array's cells with two alternating values. In further embodiments, the microprocessor may be configured turn on the first and second triacs in a timing pattern that corresponds to a phase-controlled wave form in the first and second phase angle arrays.

Still further embodiments include an electric grill, having a first knob, a second knob, and a display mounted on a housing; a power cable connected to a voltage line and

a neutral line; a first and second heating element inside the housing, the first and second heating elements being connected to the voltage line and the neutral line; a first and second triac connected between the voltage line and the first and second heating elements respectively; a first and second triac driver respectively in communication with the first and second heating elements; a zero crossing detection unit configured to detect zero crossings of AC current in the voltage line; and a microprocessor in communication with the first and second knob, the first and second triac drivers, and the zero crossing detection unit, wherein the microprocessor further communicates with a clock signal generator and a memory.

Moreover, in some embodiments the memory contains a first and second power array. the first power array may be populated with two alternating values. The second power array may be populated with two alternating values. One of the two alternating values in the first power array may represent a full “on” wave. In yet further embodiments, one of the two alternating values in the first power array may represent a full “off” wave.

Accordingly, the present invention seeks to provide a digital power supply that provides precise power control, may independently control multiple loads, and may reduce harmonic currents and flicker introduced by the power supply into a wall outlet.

Another aspect of the invention is to provide an improved power supply, including but not limited to one that may be used with an electric grill.

It is an additional aspect of the invention to provide a digital power supply that can be used in an electric grill to provide independent control over two or more heating elements.

5 It is an additional aspect of the invention to provide a digital power supply that introduces fewer harmonic currents into a wall outlet.

It is an additional aspect of the invention to provide a digital power supply that introduces less flicker into a wall outlet.

10 It is an additional aspect of the invention to provide a digital power supply for use in an electric grill that complies with standard limits and/or regulations on harmonic currents and flicker.

It is an additional aspect of the invention to provide a digital power supply for use in an electric grill to deliver variable power to two or more heating elements.

It is an additional aspect of the invention to provide a digital power supply that uses phase cutting techniques to deliver variable power.

15 It is an additional aspect of the invention to provide a digital power supply that delivers continuous variable power in a range of 0-100%.

It is an additional aspect of the invention to improve a heating element's life span by providing short duty cycles.

20 **Inventors' Definition of Terms**

The following terms which may be used in the various claims or specifications of this patent are intended to have their broadest meaning consistent with the requirement of law;

As used herein, a “power array” is defined to be an array of values, each value representing a percentage ($0.0 \leq x \leq 1.0$) of power delivery in one wave cycle. Exemplary power arrays are described as having four cells, but it should be understood that arrays of other sizes are possible.

As used herein, a “phase angle array” is defined to be an array of values, each value representing the phase angle “cut” in one wave cycle. Exemplary phase angle arrays have four cells, but it should be understood that arrays of other sizes are possible.

As used herein, a “timing pattern” is defined to be a pattern of “on” and “off” signals that create phase-controlled AC wave forms.

In a broad aspect, the present invention pertains to a method of delivering power, the method comprising accessing a selection made via one or more user input devices, the selection including a first power setting for a first heating element and a second power setting for a second heating element. An electronic signal is sent from the one or more user input devices to a microprocessor, the electronic signal to electronically communicate the power settings to the microprocessor. Using the microprocessor, a total amount of power requested is calculated. The microprocessor stores, in memory, a first power array corresponding to the first heating element, and a second power array corresponding to the second heating element. The microprocessor calculates a first phase angle array and a second phase angle array. The first phase angle array includes numeric values representing a first phase-controlled AC wave corresponding to the second power array. A zero crossing signal is sent from a zero crossing detection unit to the microprocessor, the first phase-controlled AC wave pattern being delivered based on the first phase angle array to the first heating element, and the second phase-controlled AC wave pattern based on the second phase angle array to the second heating element.

In a further aspect, the present invention provides a digital power supply comprising a first and second user input for selecting a power level of the digital power supply, a first and second triac connected to a voltage line, and a first and second triac driver respectively in communication with the first and second triac. A microprocessor is in communication with the first and second triac drivers and in communication with the first and second user input. The microprocessor is configured to calculate a total power requested by the first and second inputs and to populate a first and second power array based on

the total power requested, and is configured to calculate a first array of phase angles and a second array of phase angles based on the respective values of the first and second power array. The first array of phase angles includes numeric values representing a first phase-controlled AC waveform corresponding to the first power array, and the second array of phase angles includes numeric values representing a second phase-controlled AC waveform corresponding to the second power array.

In a still further aspect, the present invention provides an electric grill comprising a first knob and a second knob, a display mounted on a housing of the electric grill, and a first and second heating element inside the housing, the first and second heating elements being connected to a voltage line and a neutral line via a power cable. A first triac is connected between the voltage line and the first heating element, a second triac is connected between the voltage line and the second heating element, a first triac driver being in communication with the first triac, and the first triac driver being configured to activate or deactivate the first triac. A second triac driver is in communication with the second triac, the second triac driver being configured to activate or deactivate the second triac. A zero crossing detection unit is configured to detect zero crossing of AC current in the voltage line, and a microprocessor is in communication with the first and second knob, the first and second triac drivers, and the zero crossing detection unit. The microprocessor further communicates with a clock signal generator and a memory. The microprocessor executes machine-readable instructions to cause the microprocessor to at least generate a first power array corresponding to the first heating element, the first power array being based on a first power setting of the first knob. A second power array corresponding to the second heating element is generated, the second power array being based on a second power setting of the second knob. A first phase angle array and a second phase angle array are calculated including numeric values representing phase-controlled AC waves corresponding to the first power array and the second power array. The first phase angle array includes numeric values representing a first phase-controlled AC wave corresponding to the first power array, and the second phase angle array includes numeric values representing a second phase-controlled AC wave corresponding to the second power array. The microprocessor executes machine-readable instructions to cause delivery of the first phase-controlled AC wave pattern based on the first phase angle array to the first heating element, and cause delivery of the second phase-controlled AC wave pattern based on the second phase angle array to the second heating element.

Where alternative meanings are possible, in either the specification or claims, the broadest meaning is intended consistent with the understanding of a person of ordinary skill in the art. All of the words used in the claims are intended to the use in the normal, customary usage of grammar, the trade and the English language.

5 **Drawings**

Figure 1A is a front view of an exemplary grill of the present invention.

Figure 1B is a top schematic view of a cooking surface of a representative grill showing representative internal components.

10 Figure 2 is a schematic of an exemplary embodiment of a circuit, including a digital power supply circuit of the present invention.

15

20

25

Figure 3A is an exemplary wave form with a 90 degree cut of the present invention.

Figure 3B is an exemplary wave form with a 90 degree cut of the present invention.

5 Figure 3C shows harmonic currents plotted against standard limits showing harmonic currents by a 1150W element.

Figure 4A is an exemplary cut wave form followed by an “on” wave of the present invention.

10 Figure 4B is an exemplary cut wave form followed by an “on” wave of the present invention.

Figure 4C shows harmonic currents plotted against standard limits showing harmonic currents by a 1150W element.

Figure 5A is an exemplary cut wave form followed by an “off” wave of the present invention.

15 Figure 5B is an exemplary cut wave form followed by an “off” wave of the present invention.

Figure 5C shows harmonic currents plotted against standard limits showing harmonic currents by a 1150W element.

20 Figure 6 is a flow chart of an exemplary microprocessor configuration of the present invention.

Figure 7 is an exemplary algorithm for populating a power array of the present invention.

Figure 8 shows exemplary power delivered to two heating units over a period of time of the present invention.

5 Figure 9 shows exemplary power delivered to n-number of heating units of the present invention.

Figure 10 is a flow chart of exemplary inputs and outputs to a microprocessor of the present invention.

Figure 11 shows standard (IEC 61000-3-3) limits for flicker.

10 **Detailed Description of the Preferred Embodiments**

Set forth below is a description of what is currently believed to be the preferred embodiments or best representative examples of the inventions claimed. Future and present representative or modifications to the embodiments and preferred embodiments are contemplated. The present inventions may be used on and/or part of electrical grills with current protection circuitry as discussed in the co-pending patent application
15 CA2,971,815 entitled “Electric Grill With Current Protection Circuitry” filed by Applicant on the same day as this application and assigned to Weber-Stephen Products LLC, and which may be referred to for further details.

20

25

The present inventions generally include a digital power supply that can provide independent power control, and continuous variable power, for two or more electrical loads. Embodiments of the present inventions may reduce the amount of harmonics and/or flicker introduced into a power system. A person of ordinary skill in the art would
5 recognize that the digital power supply may be used to supply any electrical load or combinations of loads, including heaters, motors, and the like. In a preferred embodiment described herein, exemplary loads are heating elements found in an electric grill.

Electric grills are a suitable application for a digital power supply with independent load control because a user may wish to have higher heat on one side of an
10 electric grill and lower heat on the other side of the grill. Such an arrangement allows a user to simultaneously grill various foods requiring different temperatures, or to use indirect grilling methods. Examples of indirect grilling methods include placing foods on one side of a cooking surface while heating another side, thereby avoiding direct contact between the food and the heat source. A further benefit of variable power is that it allows
15 a user to input a power setting and achieve targeted temperatures. This makes it possible to cook at low temperatures for prolonged periods of time.

Referring now to the drawings, FIGS. 1-11 show preferred embodiments of an electric grill **110** and a digital power supply **200**. By way of example, Figures 1A and 1B show an electric grill **110**. Figure 1A shows the exterior of electric grill **110**, including a
20 housing **106**, onto which left and right control knobs **101** and **102**, as well as display **103**, may be mounted. The electric grill **110** may include a power cord **107** for connecting to an AC wall outlet. Left and right control knobs **101** and **102**, and display **103**, may connect to a microcontroller **213** which is described in greater detail herein.

As shown in Figure 1B, left and right control knobs **101** and **102** may be associated with a first and second heating element, **203** and **204**, respectively, thus creating dual cooking zones. A representative grate or cooking surface **112** is also shown in Figure 1B. Each heating element **203** and **204** may be controlled independently by a knob **101**, **102** or any other controller associated with the heating element **203**, **204**. Left knob **101** and right knob **102** may be positioned on the exterior of a grill housing **106**. The knobs **101** and **102**, or any other input device that will be understood by those of skill in the art, may be connected to a microprocessor **213** to set the operating mode of one or more heating elements **203**, **204**.

Using knobs **101** and **102**, or any other input device such as a touch screen or buttons, a user may select an operating mode for each heating element **203** and **204**. The operating mode may include a desired temperature or power setting for the heating element. Microprocessor **213**, described in further detail herein, controls the electric current delivered to heating elements **203** and **204** in order to deliver the selected power. Microprocessor **213** can achieve a desired temperature for each heating element **203** and **204** using a feedback loop in which it receives a current temperature reading from thermocouples **221** and **222**, which are proximally positioned by respective heating elements **203** and **204**. A person of ordinary skill in the art would recognize that various types and numbers of knobs, heating elements, temperature sensors and/or displays may be used.

The electric grill **110** may optionally include a display **103** or other user interface. In one example the display **103** may be connected to microprocessor **213** and display information relating to the current settings or operation of one or more of the heating

elements **203**, **204**. For example, the display **103** may show the current temperature in the proximity of heating elements **203** and **204** (as measured by thermocouples **221** and **222**), as well as the desired temperature or power setting a user has selected via knobs **101** and/or **102**.

5 Turning now to Figure 2, in general, non-limiting terms, digital power delivery may be accomplished by a microprocessor **213** which receives a user's desired power setting(s) and controls triacs **208** and **209** to enable (or disable) AC current to flow from voltage line **201** through heating elements **203** and **204** and return to a wall outlet through neutral **202**. Additionally provided herein is a specifically configured microprocessor **213**
10 which may control the flow of AC current to the heating elements **203** and **204** in a manner that reduces the amount of harmonic current and flicker introduced by the electric grill **110** to the AC wall outlet.

 As shown in the embodiment of Figure 2, microprocessor **213** is in communication with triac drivers **211** and **212**, which in turn control respective triacs **208**
15 and **209**. The mechanism by which microprocessor **213** may deliver power to heating elements **203** and **204** is by turning triacs **208** and **209** on or off (sometimes referred to as "enabled" and "disabled," respectively) via their corresponding triac drivers **211** and **212**.

 Specifically, triacs **208** and **209** turn "on" when they are triggered by a pulse from
20 microprocessor **213**. Current continues to flow until an AC current wave crosses zero. After a zero crossing, a triac turns off and remains off until the next time microprocessor **213** turns it on. In an example where AC current is 60Hz, such as a typical wall outlet, a zero crossing occurs every 1/120th of a second. A zero crossing detection unit **210** is

provided to communicate a signal to microprocessor **213** each time an AC wave crosses zero. Using this signal, microprocessor **213** can synchronize its timing to the alternating current's zero crossings.

Instead of permitting direct communication between microprocessor **213** and
5 triacs **208** and **209**, triac drivers **211** and **212** are used to interface between
microprocessor **213** and triacs **208** and **209**. Triac drivers can control a high voltage triac
with a low voltage DC source (such as a microprocessor) (Figure 2). Moreover, triac
drivers are used to isolate devices from a potentially high current or voltage in a triac.
Triac drivers **211** and **212** interface between microprocessor **213** and triacs **208** and **209**
10 while at the same time keeping microprocessor **213** isolated from voltages and currents in
triacs **208** and **209**.

An "on" triac allows current to flow through it, whereas an "off" triac does not
allow current to flow. Thus, an "on" triac **208** permits AC current to flow (from voltage
line **201**) through first heating element **203** and an "on" triac **209** permits AC current to
15 flow (from voltage line **201**) through second heating element **204**. To say that
microprocessor **213** delivers power to a heating element **203** and/or **204** implies that
microprocessor **213** enables the respective triac driver, which turns the relevant triac "on"
and allows AC current to flow from line **201**. Throughout this disclosure, it should be
understood that references to microprocessor **213** delivering power to a heating element
20 mean that microprocessor **213** is activating a given heating element's triac Driver via an
"on" or "enable" pulse signal.

As a person of ordinary skill would understand, triacs are three electrode devices,
or triodes, that conduct alternating current. Triacs are a type of solid state bidirectional

switch. Although this disclosure describes a digital power supply that uses triacs, it should be understood that any solid state bidirectional switch may be used instead of a triac. Heating elements **203** and **204** may be resistive heaters which increase in temperature as more current passes through them. Exemplary heating elements may draw 1150 Watts. Other heating elements **203**, **204** may also be used as will be understood by those of skill in the art.

In embodiments of the invention, microprocessor **213** may optionally receive temperature feedback from one or more thermocouples **221** and **222** located proximately to each heating element **203** and **204** in order to recognize when a desired temperature has been achieved. Figure 1B shows an example of thermocouples **221** and **222** adjacent to each heating element **203** and **204**. In an embodiment, the feedback may be used by microprocessor **213** to adjust the current delivered to the heating elements **203** and **204** until the desired temperatures selected by knobs **101** and/or **102** is achieved. As a result, a user can (independently) select a desired operating mode for heating elements **203** and **204**. In embodiments of the invention, microprocessor **213** may control the current delivered until a desired temperature setting is reached and then maintain the desired temperature.

Turning next to the operation of microprocessor **213**, microprocessor **213** may be configured to deliver an appropriate amount of power (as selected by the user) by toggling triacs **208** and **209** between "on" and "off." As described above, an enabled (or "on") triac **208** or **209** allows AC current to flow from line **201** through heating elements **203** or **204**, respectively. Therefore it follows that a longer "on" period allows more AC

current to flow and therefore delivers more power. Conversely, a longer "off" period results in lower power delivery.

In embodiments of the invention, microprocessor **213** may use phase angle control techniques to create a pattern of toggling between "on" and "off." The control pattern created by toggling between "on" and "off" controls the phase angle of AC
5 current (and by extension, power) flowing from voltage line **201** through heating elements **203** and **204**. This type of control pattern is sometimes referred to as "phase cutting," because AC current's wave forms may be "cut" off. Waves are cut by disabling the flow of current during part of an AC wave cycle. In this way, part of the wave
10 becomes "cut" off. The timing pattern of "on" and "off" creates a phase-controlled wave. To determine the correct angle at which to cut a wave for a desired power delivery, microprocessor **213** solves the equation:

$$(\text{angle}) = \arccos (2x-1)$$

where x is the desired power delivery (expressed as a percentage: $0.0 \leq x \leq 1.0$).

15 Microprocessor **213** is programmed to solve for the angle at which to cut the AC sine wave delivered to heating elements **203** and **204**. This disclosure refers to angles in "degrees," but a person of skill in the art would understand that every angle measurement may be converted into the unit "radians."

An example is provided in Figure 3A, which illustrates an example where
20 microprocessor **213** cuts an AC wave at 90° . A 90° cut produces a wave that delivers half (i.e. 50%) of the total available power. Figure 3A shows one wave cycle of an AC current. A person of skill in the art would understand that a complete wave has a positive

half and a negative half. The wave cycle begins at **301** where the current's value is zero. The area between **301** and **303**, numbered **302** is shaded gray to indicate a triac is not enabled and therefore current is not being delivered. At **303**, which represents a 90° phase angle, microprocessor **213** sends a pulse signal to activate a triac and thus allow current to flow through a heating element. (Stated differently, microprocessor **213** begins delivering power at **303**). At **305**, current crosses zero and the triac turns off. The triac remains off until **307**, which represents a 270° phase angle. At 270°, microprocessor **213** again sends an activating pulse and current flows for a 90° phase, between **307** and **309**, i.e. from 270° to 360°.

10 In sum, Figure 3A shows microprocessor **213** delivering power for the areas marked **304** and **308**, each representing 90° phases, for a combined 180°. No power is delivered for the shaded areas marked **302** and **306**, also representing 90° each, for a combined 180°. In this way, microprocessor **213** has delivered half, or 50%, of the power that was available. To deliver a different power percentage, microprocessor **213** may send an activating pulse earlier in a half-wave to deliver more power, or later in a half wave to deliver less power. For any desired power percentage, the appropriate phase angle cut may be calculated by microprocessor **213** solving for $(\text{angle}) = \arccos(2x-1)$. In the example of Figure 3A, a 50% power deliver was selected. Therefore, microprocessor **213** executed the calculation $(\text{phase angle}) = \arccos(2*0.5 - 1) = 90^\circ$. Figure 3B removes the “cut off” wave portions of Figure 3A and shows only the power actually delivered.

Turning now to Figure 3C, a graph is provided which shows the harmonic currents introduced into a power system by a 90° phase cut described in Figures 3A and 3B. In other words, these plotted harmonic currents may be introduced into a building's

power lines when an electric grill is plugged into a wall outlet and makes the 90° phase cut described in Figures 3A/3B. The plot is made using a 1150W heating element. Introducing harmonics is undesirable because it leads to electromagnetic interference. Moreover, there are standards, such as *IEC 61000-3-2 Electromagnetic compatibility (EMC) - Part 3-2*, which limit the level of harmonic currents that may be introduced into a wall outlet by a device. The harmonic current limits are plotted as line segments in the graph of Figure 3C. As will be clear from Figure 3C, the harmonic currents (plotted as points) introduced by the 90° phase cut exceed the harmonic limits (plotted as line segments). In other words, the graph in Figure 3C shows that the points (representing the RMS current) are higher than the lines which mark the harmonic limits.. This means that the wave forms of Figures 3A/3B have high harmonic currents and do not comply with the IEC standard. For example, RMS current at point **310** is one example of a harmonic current that exceeds (i.e., is above) the harmonic limit **311**.

Therefore, embodiments of the inventions include a microprocessor **213** specially configured to deliver power to electric loads using wave cuts that induce harmonic currents having reduced magnitudes. As an initial matter, Applicants' testing has shown harmonic currents' magnitudes are reduced when a wave cut is immediately followed by a full wave cycle "on" or a full wave cycle "off." Applicants' test results are shown in Figures 4 and 5. In particular, Figure 4A shows a first wave cycle having the same 90° cut as in Figure 3A, but is followed by a subsequent second wave cycle (between **409** and **410**) that is fully "on." Similarly, Figure 5A shows a first wave cycle having the same 90° cut as Figure 3A, and additionally followed by a second full wave cycle (between **509** and **510**) that is fully "off." For clarity, Figures 4B and 5B show the same respective

patterns without the “cut” portions of a wave. Applicants’ testing, shown in Figures 4C and 5C, shows that a 90° cut induces fewer harmonics when it is followed by a subsequent full “on” or a full “off” wave cycle. These results can be seen in Figures 4C and 5C, where the plotted harmonic currents (points) are now below the harmonic current limits of the IEC standard (plotted as line segments), and are noticeably lower than the harmonic currents plotted in Figure 3C. By way of example, Figure 4C shows an exemplary RMS current point **410** that is below the harmonic limit **411**. Unlike Figure 3C, the RMS currents of Figure 4C are under the harmonic limits. The same applies to Figure 5C, where exemplary current point **510** is under the harmonic limit of **511**.

10 Therefore, embodiments of the inventions include a microprocessor **213** specifically configured to follow a cut wave with either a full “on” or a full “off” wave. Moreover, microprocessor **213** may be specifically configured to draw current in a pattern that reduces harmonic currents while still managing to split the drawn current among two independent heating elements **203, 204**. In other words, microprocessor **213** must manage the pattern of the overall current drawn by the electric grill **110** while simultaneously satisfying the power requirements of both independent heating elements **203, 204**. The pattern of the overall current drawn by electric grill **110** may be referred to as the electric grill **110**’s total power array. The electric grill **110**’s total power array is the sum of the first heating element **203**’s power array plus the second heating element **204**’s power array. An exemplary power array may be four cells, each cell containing a value ($0.0 \leq x \leq 1.0$) representing a percentage of power to deliver in a wave form. Thus, an exemplary power array may represent a pattern of four waves. It will be understood that the total power (or, current) drawn by electric grill **110** is the sum of the power

(current) drawn by the heating elements. The wave form patterns delivered to the heating elements **203**, **204** may likewise be represented as four-celled power arrays. The first heating element's power array summed with the second heating element's power array equals the electric grills total power array. The same holds true for any number of heating elements in an electric grill **110**. The electric grill **110**'s harmonic currents depend on the pattern of waves drawn by the electric grill **110**, represented in the total power array. To reduce harmonic currents, electric grill **110**'s total power array should represent a pattern where each "cut" wave is followed by a full "on" or a full "off" cycle.

Figure 6 is a flow chart showing an exemplary configuration of microprocessor **213** for controlling two heating elements while introducing fewer harmonics. Generally speaking, microprocessor **213** calculates a power array to deliver to each heating element **203**, **204**. The power arrays depend on a user's power settings for each of the two heating elements **203**, **204** as well as feedback from thermocouples **221** and **222**. In this example, each power array consists of four cells (but another number of cells may be used), each cell containing a number ranging between $0.0 \leq x \leq 1.0$. Each of the four cells represents a wave cycle, the cell's number indicating the percentage of power delivered during that wave cycle. By way of example, an array of "1 | 0 | 1 | 0" would represent one "on" wave, one "off" wave, another "on" wave, and another "off" wave. Microprocessor **213** delivers the wave forms from the two calculated power arrays to the two heating elements **203**, **204** by toggling the triac drivers **211** and **212** in the manner described above.

Addressing Figure 6 more particularly, microprocessor **213** communicates with a first and second user input device, such as a left knob **101** and a right knob **102**. The first and second user input devices convey a power level for each of the two heating elements

203, 204. The desired power levels can be converted by microprocessor 213 into a percentage of total power at steps 601 and 602. Microprocessor 213 determines if the total power 603 is greater than or equal to 50% at step 604.

At 605, where a user's selected total power is less than 50%, microprocessor 213
5 begins filling (or, "populating") the cells of the first power array. Figure 7 shows the steps microprocessor 213 is configured to execute to fill, or populate, a power array. As seen in Figure 7, microprocessor 213's calculation begins at 701 with the total power requested by a user. (This is the sum of the power requested for the right heating element and the power requested by the left heating element as determined in 603). The
10 percentage of total power requested is multiplied by 8 (because there are 2 arrays x 4 cells each) at step 702. The value of step 702, herein referred to using the notation [702], is used to populate a power array at 703. If the value of 702 is less than or equal to 2.0, the value of 702 is distributed evenly between the first and third array elements to arrive at: " $([702]/2) | 0 | ([702]/2) | 0$." This is seen at step 704. If the value of 702 is greater
15 than 2.0, then the first and third array elements are filled with "1," and the remainder (subtracting 2 from the value of 702) is distributed evenly between the second and fourth cells. This is seen at 705. Using this technique, a power array is constructed to have a full "on" or a full "off" wave that follows a cut wave to reduce the magnitude of harmonic currents. Moreover, the power array's alternating pattern reduces flicker, as described in
20 more detail below. Returning now to Figure 6, the second power array is filled with four zeros: "0 | 0 | 0 | 0" at step 606.

Again by reference to Figure 6, if the Total Power 603 equals or exceeds 50%, microprocessor 213 fills the first power array with all 1's (" $1|1|1|1$." at step (607).

Microprocessor **213** then populates the second power array using the conditions of **706** and **707**. Regardless of whether the user has requested more or less than 50% power, one of the two power arrays will have the alternating pattern "A | B | A | B," while the other array will have the pattern "C | C | C | C," where C = 0 or 1. Once the first and second
5 power array have been populated, they are delivered to the heating elements **203** and **204**.

Power is delivered by microprocessor **213** to a triac driver based on the values in the four cell power arrays. As described above, each cell represents one full wave cycle, and the cell's numeric value represents the percentage of power to deliver in that wave cycle. As also described above, embodiments of the inventions may use phase cutting
10 techniques to control power. Thus, at step **609**, microprocessor **213** is configured to calculate the phase angle at which to "cut" a wave in order to achieve the power represented by a cell in a power array. Microprocessor **213** is configured to solve the equation:

$$(\text{angle}) = \arccos (2 * \text{power} - 1),$$

15 where "power" is the power represented by a number in a power array's cell. Microprocessor **213** uses this angle to deliver a wave cycle having power that corresponds to the cell's numeric value. The calculation may be repeated for each cell in each power array. Each cell of each power array may be converted into a corresponding phase angle **610** and **611**. The corresponding phase angle arrays contain phase angles,
20 rather than power percentages, and may be stored in the same format as the power arrays.

At step **614**, microprocessor **213** may synchronize its timing to the phase angle of AC current in line **201**. As described above, microprocessor **213** receives a zero crossing

signal from zero crossing detection **210** each time the AC current crosses zero from zero crossing detection unit **210**. The zero crossing signal can thus synchronize microprocessor **213**'s timing (and therefore by extension, the angle) of an AC wave. For example, a person of skill in the art would then recognize that a wave of AC current has

5 the following angles at the indicated points in time:

Desired phase angle "cut"	60 Hz AC current: Time (where zero crossing is t=0)
0°	0 seconds
10°	0.000462963 seconds
20°	0.000925926 seconds
30°	0.001388889 seconds
40°	0.001851852 seconds
50°	0.002314815 seconds
60°	0.002777778 seconds
70°	0.003240741 seconds
80°	0.003703704 seconds
90°	0.004166667 seconds

Table 1.

Using this information, microprocessor **213** may use an internal timing mechanism, such as a clock signal generator or any other appropriate mechanism, to send the "on" or "enable" pulse at an instance corresponding to the angle required for the correct "cut." For example, Table 1 shows that a 90 degree cut would be made by
 10 activating a triac 0.004166667 seconds after a zero crossing. Microprocessor **213** may use a clock signal to enable a triac at the appropriate point in time. A person of skill in the art

reading this disclosure would understand how to calculate the timing for any desired wave “cut.”

Turning now to steps **612** and **613**, the first power array is delivered to the first triac driver **211** and the second power array is delivered to the second triac driver **212** for
5 a period of time equal to $T1$. This power delivery continues repeatedly for a first time period $T1$, after which microprocessor **213** delivers the first power array to the second triac driver **211** and delivers the second power array to the first triac driver **212** repeatedly for a second time period $T2$. After $T1$, delivery is “flipped” and the first triac driver **211** receives the second power array for duration of $T2$. The first and second
10 power array, summed together, equal the electric grill **110**’s total power array – thus, by definition, the first and second power array must always be delivered simultaneously.

The discussion now turns to the calculation of time periods $T1$ and $T2$ at **615** and **616**. The purpose of time periods $T1$ and $T2$ is to “split,” or pro-rate, the total power drawn by the electric grill (or any other device using embodiments of the invention)
15 between the two heating elements (or any other electric load) according to the independently selected power for each respective heating element. The power arrays created at steps **605** through **608** create an acceptable wave pattern for the electric grill as a whole. The sum of the power arrays, which is the electric grill **110**’s total power array, will have a full “on” or full “off” wave following each cut wave, which reduces the
20 magnitude of harmonic currents. It is additionally necessary to calculate the delivery time of each power array to the respective heating elements **203**, **204**.

The time period T1 is calculated by taking the power setting for the first heating element **203** and dividing it by the total power selected, **603**. That ratio is then multiplied by the power delivery phase, which is 2 seconds in this example but may be varied. T1 and T2 are simple ratios of a given heating element's power setting compared to the total requested power. The calculation may be summarized by the following equation:

$$T1 = 2 \text{ seconds} * (\text{power selection for first heating element}) / ((\text{power selection for first heating element}) + (\text{power selection for second heating element})).$$

Similarly, T2 is the same calculation, this time for the second heating element **204**:

$$T2 = 2 \text{ seconds} * (\text{power selection for second heating element}) / ((\text{power selection for first heating element}) + (\text{power selection for second heating element})).$$

Figure 8 summarizes microprocessor **213**'s power delivery of the first and second power array to the first and second triac drivers over a power delivery phase of 2 seconds: the first triac driver **211** (and by extension first heating element **203**) receives the waves represented by the first power array for a time T1. It then receives waves represented by the cells of the second power array for a time T2. Conversely, the second triac Driver **212** (and by extension the second heating element **204**) receives waves represented by the cells of the second power array during the time period T1, and then receives waves represented by the cells of the first power array during the time period T2.

Embodiments of the present invention may be scaled to independently deliver power to more than two loads. In an embodiment where a digital power supply independently controls "n" number of loads, n power arrays are required. Moreover, the

decision at **604** would compare the total power to $100\%/n$. The technique for filling the power arrays of Figure 7 remains applicable, although rather than multiply by eight (8), it would be necessary to multiply step **702** by $(n * 4)$. Moreover, at steps **615** and **616**, n time periods are required. Figure 9 shows the timing of n -power arrays delivered across n -time periods. It should be understood that embodiments with multiple heaters without independent control are also contemplated by this disclosure.

The present inventions also provide methods for independently controlling two heating elements and providing variable power while providing reduced harmonic currents and flicker. In an embodiment of the invention, a user activates electric grill **110** and selects a first and second power level, for example by controlling knobs **101** and **102**. By activating an electric grill **110**, a user controls microprocessor **213** to execute the following steps for the benefit of controlling one or more heating elements. It is understood that some embodiments may include any number of knobs or other user inputs. By activating the electric grill **110**, a user turns on microprocessor **213**. Microprocessor **213** receives the user's selected power settings and performs the above-described calculations to activate triac drivers **211** and **212** in a control pattern that delivers phase-controlled wave forms to heating elements **203** and **204**.

In embodiments of the invention, microprocessor **213** performs the step of calculating the appropriate phase controlled wave forms by populating two power arrays **605-608**. Each power array may have four cells. Each cell contains a number "n," where $0.0 \leq n \leq 1.0$. The number "n" represents a wave form having "n"-percentage of power. The waves are cut to eliminate "excess" power. Microprocessor **213** performs the step of filling in the power arrays by calculating the total power requested by all heating

elements **203, 204**, which may be expressed as a percentage of selected power as compared overall available power (in decimal form).

If the total power requested (i.e. the total requested power for all heating elements) by the user is less than 50% of the overall available power, microprocessor **213** performs the step of filling in the first power array (**605**). The power array is populated by distributing the total power number into the power arrays four cells. At **606**, microprocessor **213** performs the step of filling all zeros into the second power array (i.e. "0000"). If the total power requested by the user is greater than, or equal to, 50% of the overall power, microprocessor **213** performs the steps of fillings the first power array with 1's (i.e. "1 | 1 | 1 | 1") and the second power array is filled (with Total Power – 50%, i.e. [702] minus 4) according to the steps of Figure 7.

Once the first and second power array are calculated, microprocessor **213** delivers wave forms corresponding to the cells of each power array. In particular, each cell's value represents the percentage of power to deliver in one wave cycle. To deliver a wave having any given percentage of power, microprocessor **213** calculates a phase angle = $\arccos(2*x - 1)$, where x is the power percentage described in any given cell. Microprocessor **213** uses the calculated angle to deliver an "on" signal to triac Drivers **211** or **212** at a point in time corresponding to the calculated phase angle. Microprocessor **213** may use a zero crossing signal and the above-described Table 1 to determine the correct timing.

Microprocessor **213** repeatedly delivers the first power array to the first triac driver **211** and the second power array to the second triac driver **212** for a time period T1.

After T1 has passed, microprocessor **213** “flips” the first and second power array for a time period T2. In other words, as seen in Figure 8, after T1 ends and T2 begins, the first power array is delivered to the second triac driver **212** and the second power array is delivered to the first triac driver **211**.

5 Microprocessor **213** performs the step of calculating T1 and T2 as:

$$T1 = 2 \text{ seconds} * (\text{First heater total power} / \text{Combined heater total power})$$

$$T2 = 2 \text{ seconds} * (\text{Second heater total power} / \text{Combined heater total power}).$$

Mathematically, it follows that the power delivery phase of T1 + T2 = 2 seconds.

In this way, the power arrays are delivered for a combined power delivery phase
10 of 2 seconds. It is contemplated that longer or shorter power delivery phases may be used. After 2 seconds, microprocessor **213** may re-calculate the power arrays. By re-calculating the power arrays, microprocessor **213** may account for a change in user settings, or to switch from raising a heating element’s temperature to maintaining a temperature.

15 An operating example applying the devices and methods described above is provided. For example, a user may wish to use the grill **110** with different power levels for the first and second heating elements **203** and **204** – for instance, microprocessor **213** may determine that a first heating element **203** should have 17.5% of its maximum power, and a second heating element **204** should have only 5% of its maximum power. In
20 accordance with the embodiments described herein, microprocessor **213** is configured to

deliver 17.5% and 5% power, respectively, while drawing power in a pattern that reduces the harmonic currents introduced by the electric grill into the AC wall outlet.

In this example, the first and second power arrays are calculated as follows: the first and second selected power levels are combined to arrive at a total selected power:

5 17.5% + 5% = 22.5%, or 0.225 (See **603**). Because this is less than 50%, microprocessor **213** proceeds with step **605**. Using the techniques described herein, microprocessor **213** multiplies by eight (8) to arrive at $0.225 * 8 = 1.8$. Next, microprocessor **213** fills the value 1.8 into the first power array. In particular, the first cell and third cells receive the value of $(1.8)/2 = 0.9$. The second and fourth cells remain "0." Thus, the first power array

10 is "0.9 | 0 | 0.9 | 0" and the second power array is "0 | 0 | 0 | 0."

For a time period T1, the first power array is delivered to the first triac driver **211** and the second power array is simultaneously delivered to the second triac driver **212**. In delivering the first and second power array, microprocessor **213** sends an "on" signal to the respective triac driver **211** and/or **212** at a time that corresponds to the "cut" of the

15 wave. For example, the first power array's first cell dictates that a 90% power wave (i.e. 0.9) is delivered. A 90% power wave requires a "cut" angle of $\arccos(2 * .9 - 1) = 36.86^\circ$. Microprocessor **213** delivers a 90% power wave by turning triac driver **211** "on" at 36.86° . Similar to the values of Table 1, a 36.86° cut can be made by delivering power 0.0017 seconds after a zero crossing. Subsequently, the second cell dictates that an "off"

20 wave having 0% is delivered. The third wave is the same as the first wave, i.e. cut at 36.86° , and the fourth wave is the same as the second wave, i.e. "off." The second power array in this example is "0 | 0 | 0 | 0," thus the second triac driver **212** is never activated.

This delivery pattern is continued for a time period T1 as described at **612** and **613**. Here, T1 is calculated as $T1 = 2 \text{ seconds} * (\text{First heater total power} / \text{Combined heater total power}) = 2 * (0.175/0.225) = 2 * 0.78 = 1.56 \text{ seconds}$. Similarly, $T2 = 2 * (0.05/0.225) = 0.44 \text{ seconds}$. In this example, the first power array ("0.9 | 0 | 0.9 | 0") is delivered to the first heating element **203** and the second power array ("0 | 0 | 0 | 0") is delivered to the second heating element **204** for T1= 1.56 seconds. After 1.56 seconds, microprocessor "flips" the delivery of the first and second power array for a period of 0.44 seconds. After a combined 2 seconds have passed, microprocessor **213** may begin by re-filling the first and second power array according to the power needs at that point in time.

It will be understood that microprocessor **213** may include internal or external memory **1000** for reading and/or writing in connection with executing the steps and configurations described herein. Moreover, it will be understood that microprocessor **213** may have an internal or external clock signal that may be used to time the "on" signal sent to a triac. The clock signal may be generated by an on-board clock signal generator **1001**, or by an external clock. Figure 10 is an exemplary schematic showing inputs and outputs to microprocessor **213**. Examples include a left and right knob **101**, **102** and a display **103**. Additional examples include thermocouples **221**, **222**, and communication with triac Drivers **208** and **209**. Memory **1000** and clock **1001** are also shown, as is the input signal **1002** from zero crossing unit **210**.

An additional benefit of embodiments of the devices and methods described herein is a reduction in flicker introduced by the digital power supply **200** into a wall outlet. Flicker is undesirable because, at certain frequencies, it will cause lights connected

to an outlet to flicker or dim. Figure 11 shows the flicker limits of *IEC 61000-3-3 Electromagnetic compatibility (EMC) - Part 3-3 (Voltage Fluctuations and Flicker)*.

Flicker is measured as a % change in voltage.

Embodiments of the present invention may reduce flicker levels to a wall outlet
5 based on voltage changes resulting from wave-cuts within a single power delivery phase. A person of skill in the art would recognize that flicker is commonly measured during a devices “steady state.”

The voltage changes within a single power deliver phase comply with the flicker regulations. As seen at **1101** (and further described in the standard), the IEC 61000-3-3
10 requirement’s last data point occurs at 2875 voltage changes per minute. This equates to a cycling frequency of 23.96 Hz. In other words, voltage changes occurring at a frequency above 23.96 Hz have no flicker requirement because they are beyond human perception. Embodiments of the devices and methods disclosed herein create a wave pattern in which electric grill **110** alternates between a cut wave and a full “on” or a full “off” wave.
15 Following this pattern, electric grill **110** would create 25 voltage changes per second (25 Hz) at 50 Hz AC and 30 voltage changes per second (30 Hz) at 60 Hz AC. A cut wave followed by a full wave counts as one voltage change. The 25Hz and 30 Hz cycling frequencies are above the standard’s last data point of 23.96 Hz and therefore comply with flicker requirement.

20 An additional benefit of embodiments of the invention comes from splitting power into multiple power arrays and delivering them to multiple heating elements. Using the techniques described in Figures 6 and 7, one of the power arrays will always be

“0 | 0 | 0 | 0” or “1 | 1 | 1 | 1.” This ensures that only one of heating element **203** or **204** can receive a “cut” wave at any given time. As a result, the electric grill **110**’s used current (or power) will never be dropped by more than half (1/2) of the maximum rated power. To give an example, if two heating elements **203** and **204** each draw 1150 Watts, 5 for a combined 2300 Watts drawn by the electric grill **110**, then even a 90° in one heating element **203** or **204** would only result in a maximum power drop of 1150 Watts. This helps reduce the magnitude of harmonic currents.

Embodiments of the disclosed digital power supply and method for delivering power may optionally be implemented in the circuitry of an electric grill. Figure 2 shows 10 additional components that may optionally be added to the protection circuitry **200** to provide circuitry for an electric grill. For example, line **201** and neutral **202** may connect to a step down transformer **215** to which zero crossing detection unit **210** is connected. Step down transformer **215** provides a reduced secondary voltage so that zero crossing detection unit **210** may detect zero crossings in AC current between line **201** and neutral 15 **202** without being exposed to high voltages.

Further optional embodiments include a full wave rectifier **216** that feeds to a ground fault detection unit **217**, which in turn communicates with a trip controller **218** for tripping an electromechanical latch **206** or **207**. Ground fault detection unit **217** may receive a signal indicating a current imbalance between line **201** and neutral **202** and 20 cause the latches to trip to prevent hazardous current situations.

Additional optional embodiments include a watchdog monitor **220** which monitors the operation of microprocessor **213** and may disable triac drivers **211** and **212**

in the event of a failure of microprocessor 213. Also provided are AC/DC power converters 214 which may be used to power the microprocessor 213, and a current sensor, such as Hall Effect sensor 219, which may be used by microprocessor 213 to monitor the current flowing to heating elements 203 and 204.

5 For the reasons described above, some embodiments of the inventions may provide a digital power supply that increases a heating element's lifespan; complies with flicker requirements, and also complies with harmonic requirements. These benefits may be accomplished using the devices and methods described herein. For example, using a power delivery phase of 2 seconds prevents the heating elements from ever fully
10 expanding or fully contracting. Lengthy power delivery phases that allow a heating element to fully expand or contract are very detrimental to the heating element's lifespan. The flicker requirement is satisfied by creating a total power array that describes an alternating wave pattern which has a cycling frequency of 25-30Hz depending on the AC current. Moreover, the total power array that may be created using devices and methods
15 of the invention follow every cut wave with a full "on" or full "off" wave, thus reducing harmonic currents. Harmonic currents are also reduced by splitting the combined load of electric grill 110 to two or more elements.

The above description is not intended to limit the meaning of the words used in or the scope of the following claims that define the invention. Rather the descriptions and
20 illustrations have been provided to aid in understanding the various embodiments. It is contemplated that future modifications in structure, function or result will exist that are not substantial changes and that all such insubstantial changes in what is claims are intended to covered by the claims. Thus, while preferred embodiments of the present

inventions have been illustrated and described, one of skill in the art will understand that numerous changes and modifications can be made without departing from the claimed invention. In addition, although the term "claimed invention" or "present invention" is sometimes used herein in the singular, it will be understood that there are a plurality of
5 inventions as described and claimed.

Various features of the present inventions are set forth in the following claims.

WHAT IS CLAIMED IS:

1. A method of delivering power, the method comprising:

accessing a selection made via one or more user input devices, the selection including a first power setting for a first heating element and a second power setting for a second heating element;

sending an electronic signal from the one or more user input devices to a microprocessor, the electronic signal to electronically communicate the power settings to the microprocessor;

calculating, using the microprocessor, a total amount of power requested;

using the microprocessor to store, in a memory, a first power array corresponding to the first heating element and a second power array corresponding to the second heating element;

using the microprocessor to calculate a first phase angle array and a second phase angle array, the first phase angle array including numeric values representing a first phase-controlled AC wave corresponding to the first power array, the second phase angle array including numeric values representing a second phase-controlled AC wave corresponding to the second power array;

sending a zero crossing signal from a zero crossing detection unit to the microprocessor;

delivering the first phase-controlled AC wave pattern based on the first phase angle array to the first heating element; and

delivering the second phase-controlled AC wave pattern based on the second phase angle array to the second heating element.

2. The method of claim 1, wherein the first phase controlled AC wave pattern and the second phase-controlled AC wave pattern are delivered in a first time period, and further including delivering, during a second time period, a third phase-controlled AC wave pattern based on the first phase angle array to the second heating element and delivering a fourth phase controlled AC wave pattern based on the second phase angle array to the first heating element.

3. The method of claim 2, wherein each power array contains four cells.
4. The method of claim 3, wherein the using of the microprocessor to store the first power array and the second power array further includes:
 - populating a first cell of the first power array with a same value as a third cell of the first power array;
 - populating a second cell of the first power array with a same value as a fourth cell of the first power array;
 - populating a first cell of the second power array with a same value as a third cell of the second power array; and
 - populating a second cell of the second power array with a same value as a fourth cell of the second power array.
5. The method of claim 4, wherein each cell of each power array represents a power percentage and ranges from $0 \leq x \leq 1.0$.
6. The method of claim 5, wherein every alternate cell in the first power array is populated with a "0" or a "1".
7. The method of claim 6, wherein every alternate cell in the second power array is populated with a "0" or a "1".
8. The method of claim 5, wherein the first and second phase angle arrays are calculated using the microprocessor to apply the equation $\text{angle} = \arccos(2x - 1)$ to the first and second power array, respectively.

9. The method of claim 5, where in the first time period is calculated as a ratio of the first power setting to the total amount of power requested and the second time period is calculated as a ratio of the second power setting to the total amount of power requested.

10. The method of claim 5, wherein the delivering of the first phase-controlled AC wave pattern includes activating a triac connected to the first heating element.

11. A digital power supply, comprising:

a first and second user input for selecting a power level of the digital power supply;

a first and second triac connected to a voltage line;

a first and second triac driver respectively in communication with the first and second triac;

a microprocessor in communication with the first and second triac drivers and in communication with the first and second user input;

wherein the microprocessor is configured to calculate a total power requested by the first and second user inputs and to populate a first and second power array based on the total power requested; and

wherein the microprocessor is configured to calculate a first array of phase angles and a second array of phase angles based on the respective values of the first and second power array, the first array of phase angles including numeric values representing a first phase-controlled AC waveform corresponding to the first power array, the second array of phase angles including numeric values representing a second phase-controlled AC waveform corresponding to the second power array.

12. The digital power supply of claim 11, wherein the first and second power array each have four cells.

13. The digital power supply of claim 12; further comprising: wherein the microprocessor is specifically configured to populate at least one power array's cells with two alternating values.

14. The digital power supply of claim 11, further comprising the microprocessor being configured to turn on the first and second triacs in a timing pattern that corresponds to a phase-controlled wave form in the first and second phase angle arrays.

15. An electric grill, comprising:

a first knob and a second knob;

a display mounted on a housing of the electric grill;

a first and second heating element inside the housing, the first and second heating elements being connected to a voltage line and a neutral line via a power cable;

a first triac connected between the voltage line and the first heating element;

a second triac connected between the voltage line and the second heating element ;

a first triac driver in communication with the first triac, the first triac driver configured to activate or deactivate the first triac;

a second triac driver in communication with the second triac, the second triac driver configured to activate or deactivate the second triac;

a zero crossing detection unit configured to detect zero crossings of AC current in the voltage line; and

a microprocessor in communication with the first and second knob, the first and second triac drivers, and the zero crossing detection unit, wherein the microprocessor further

communicates with a clock signal generator and a memory, the microprocessor to execute machine-readable instructions to cause the microprocessor to at least:

generate a first power array corresponding to the first heating element, the first power array based on a first power setting of the first knob;

generate a second power array corresponding to the second heating element, the second power array based on a second power setting of the second knob;

calculate a first phase angle array and a second phase angle array including numeric values representing phase-controlled AC waves corresponding to the first power array and the second power array, the first phase angle array including numeric values representing a first phase-controlled AC wave corresponding to the first power array, the second phase angle array including numeric values representing a second phase-controlled AC wave corresponding to the second power array;

cause delivery of the first phase-controlled AC wave pattern based on the first phase angle array to the first heating element; and

cause delivery of the second phase-controlled AC wave pattern based on the second phase angle array to the second heating element.

16. The electric grill of claim 15, wherein the memory is to store the first power array and the second power array.

17. The electric grill of claim 16, wherein the first power array is populated with two alternating values.

18. The electric grill of claim 17, wherein the second power array is populated with two alternating values.

19. The electric grill of claim 18, wherein one of the two alternating values in the first power array represents a full “on” wave.

20. The electric grill of claim 18, wherein one of the two alternating values in the first power array represents a full “off” wave.

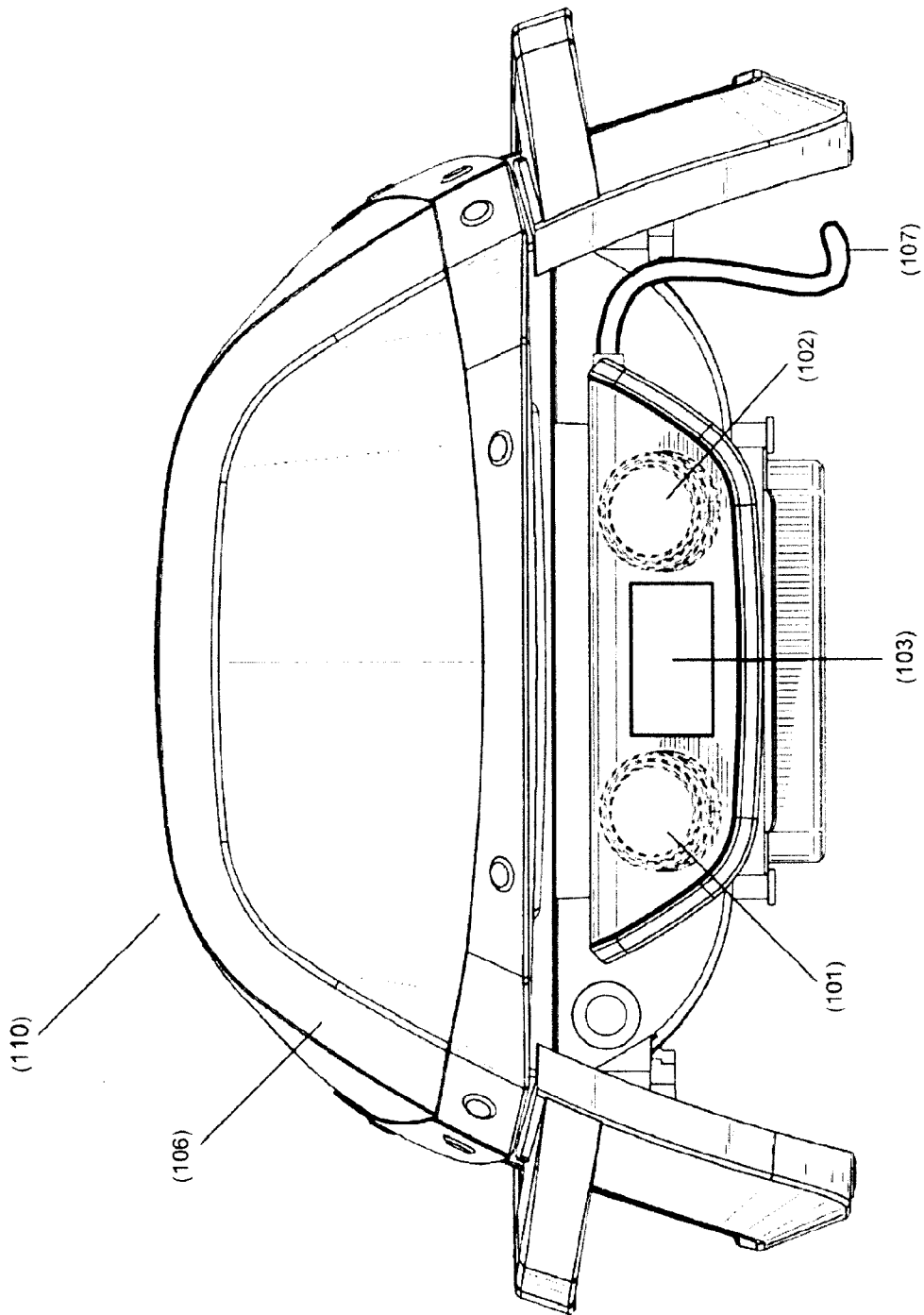

Fig. 1A

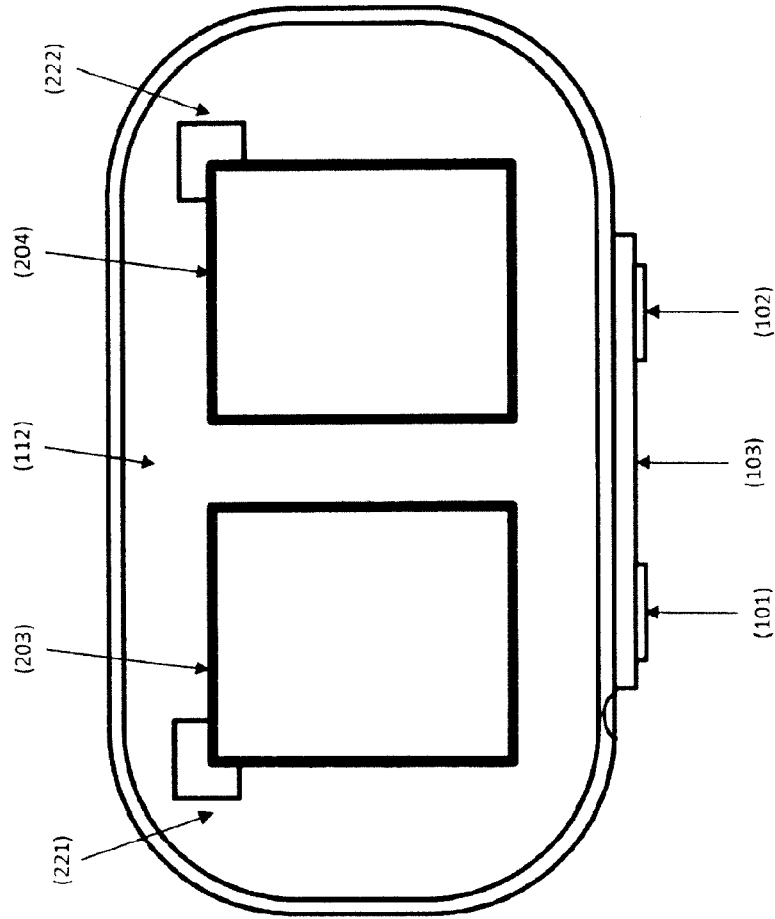

Fig. 1B

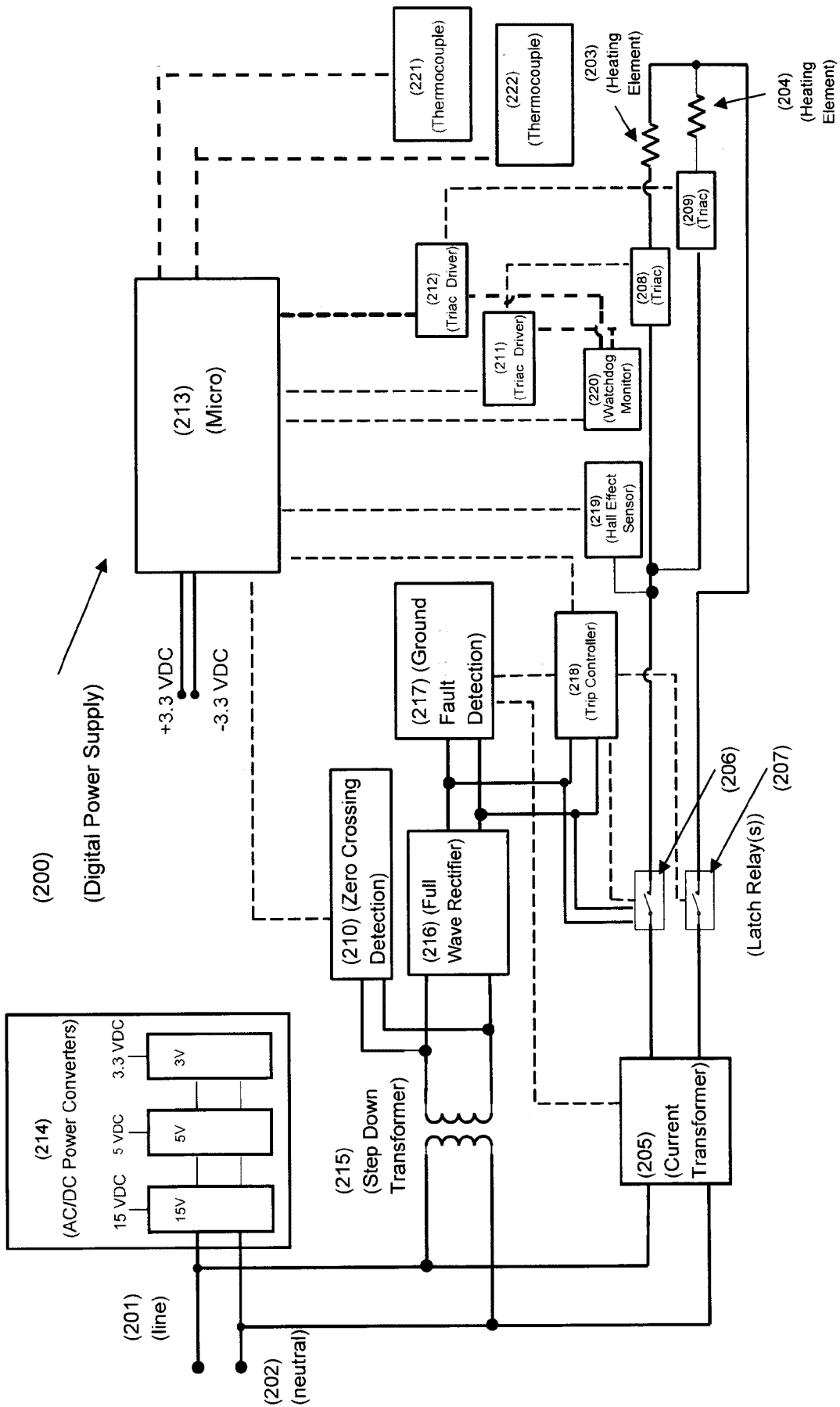

Fig. 2

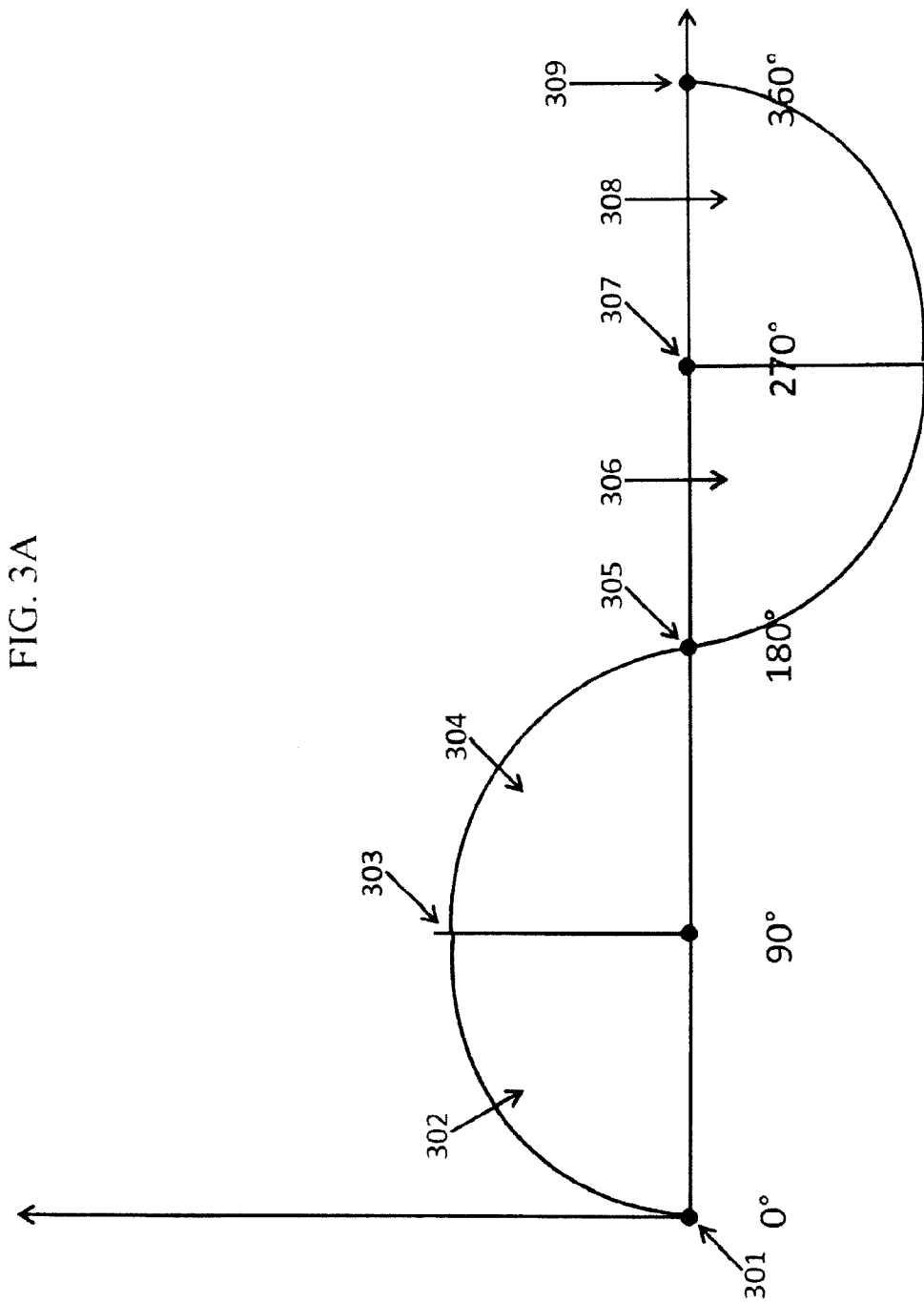

FIG. 3A

FIG. 3B

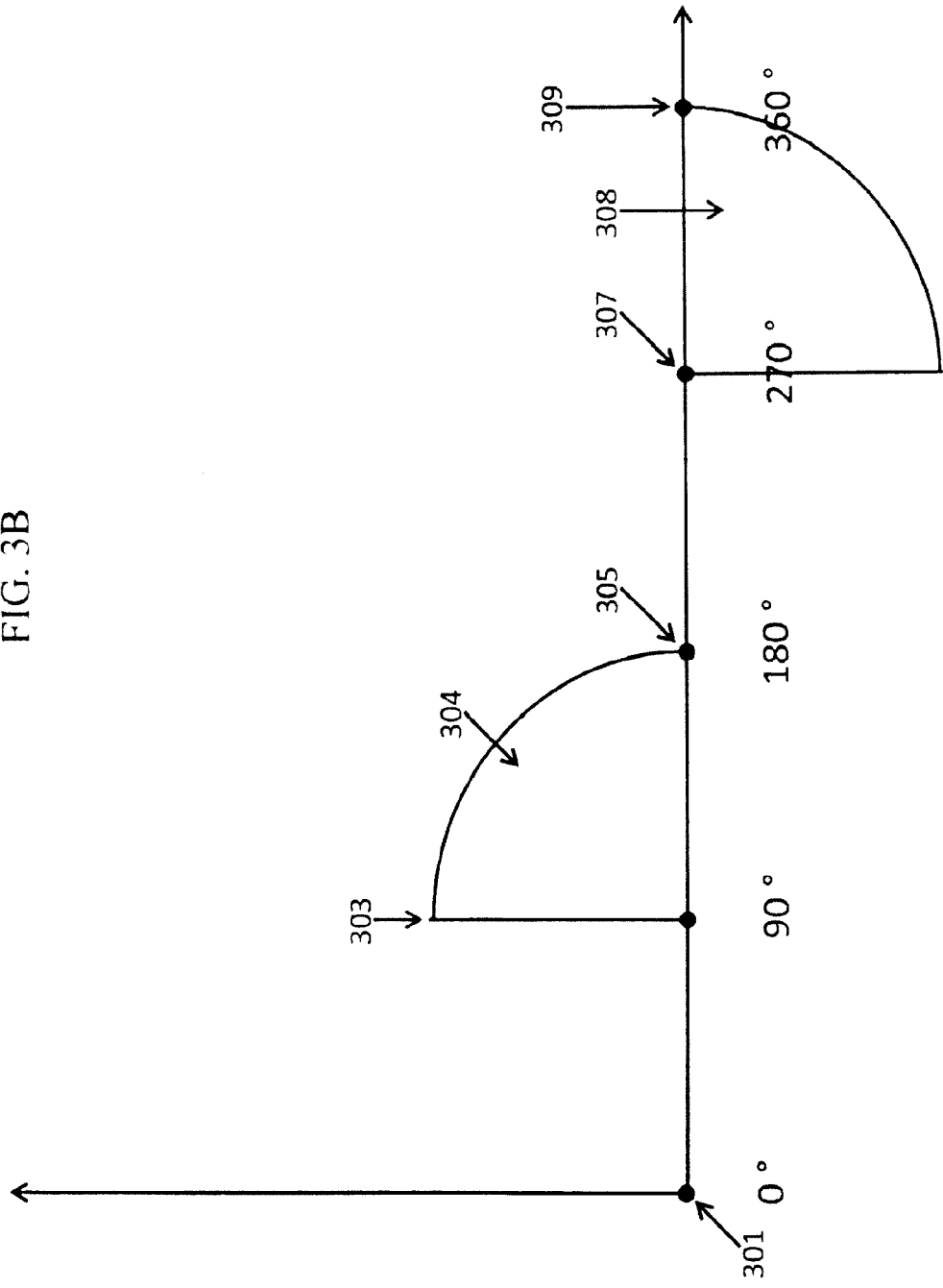

FIG. 3C

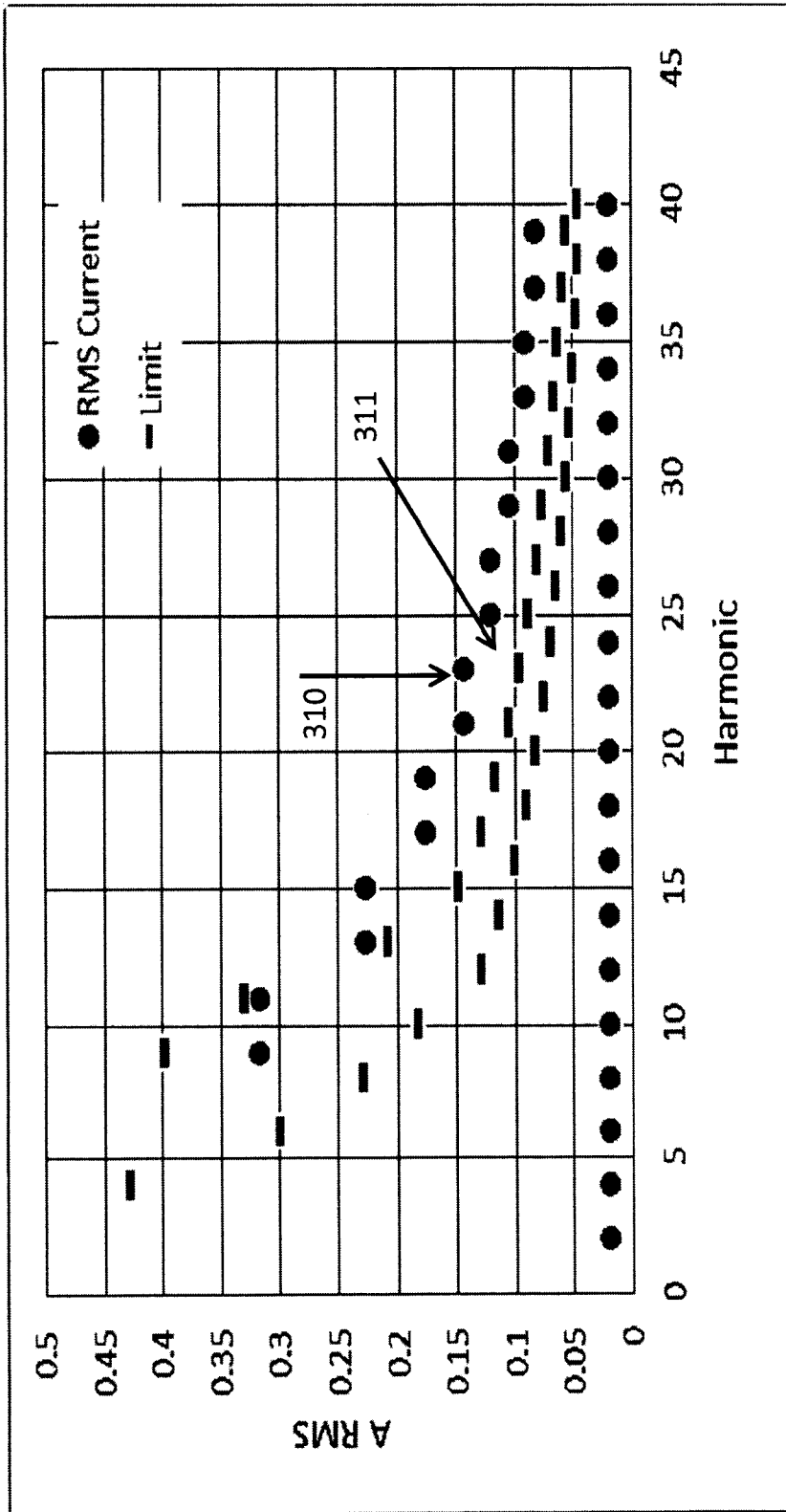
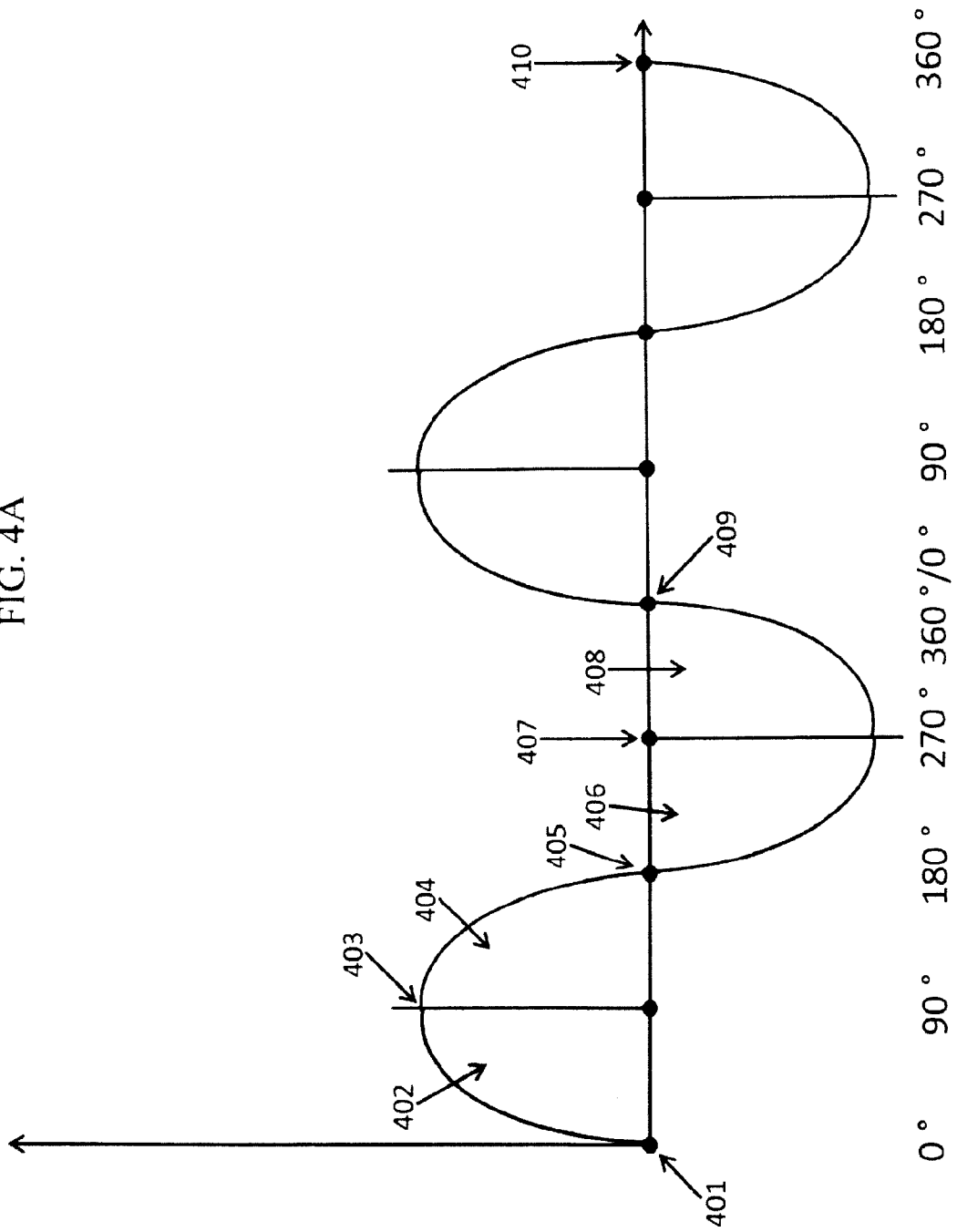

FIG. 4A



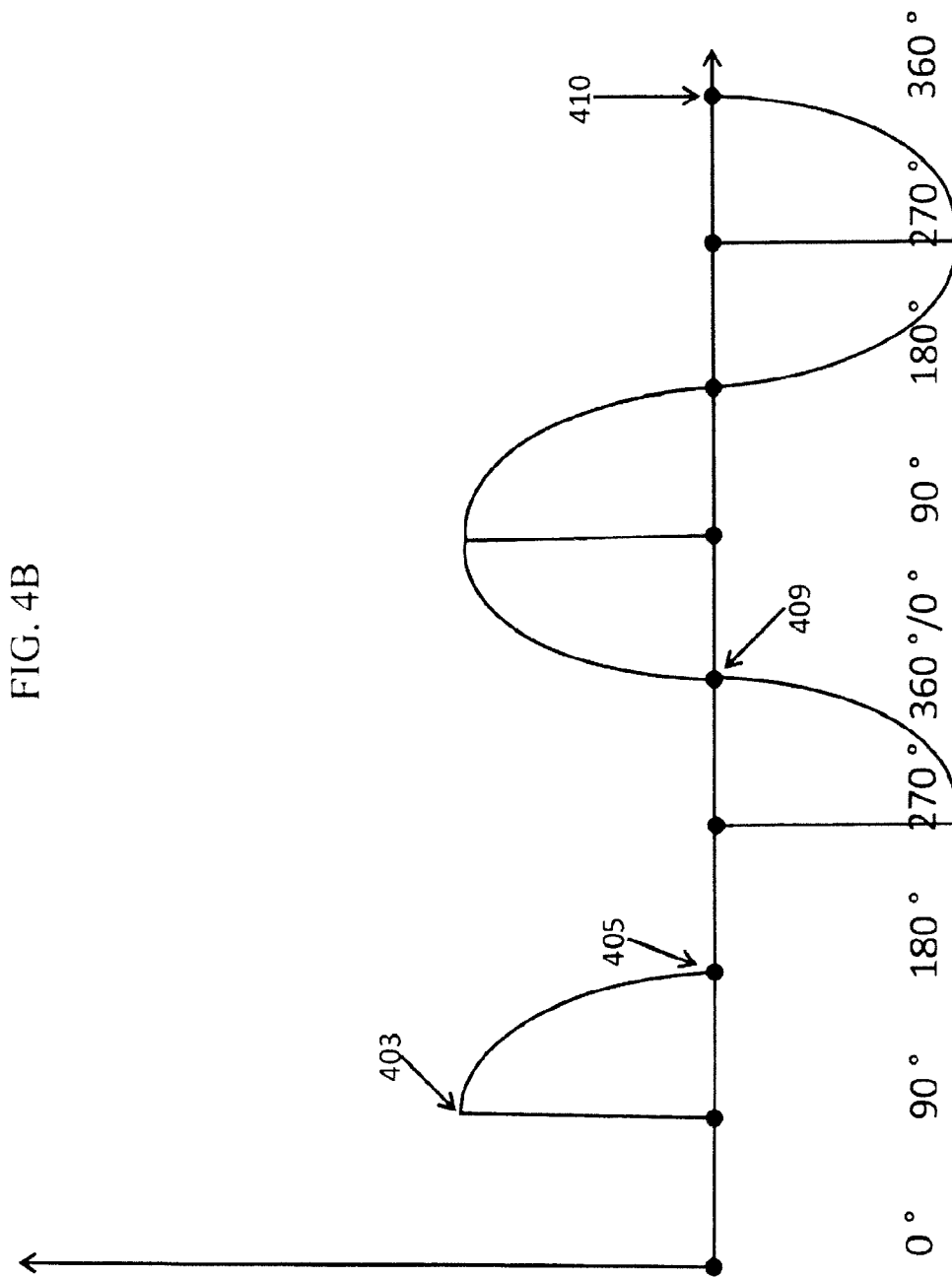

FIG. 4B

FIG. 4C

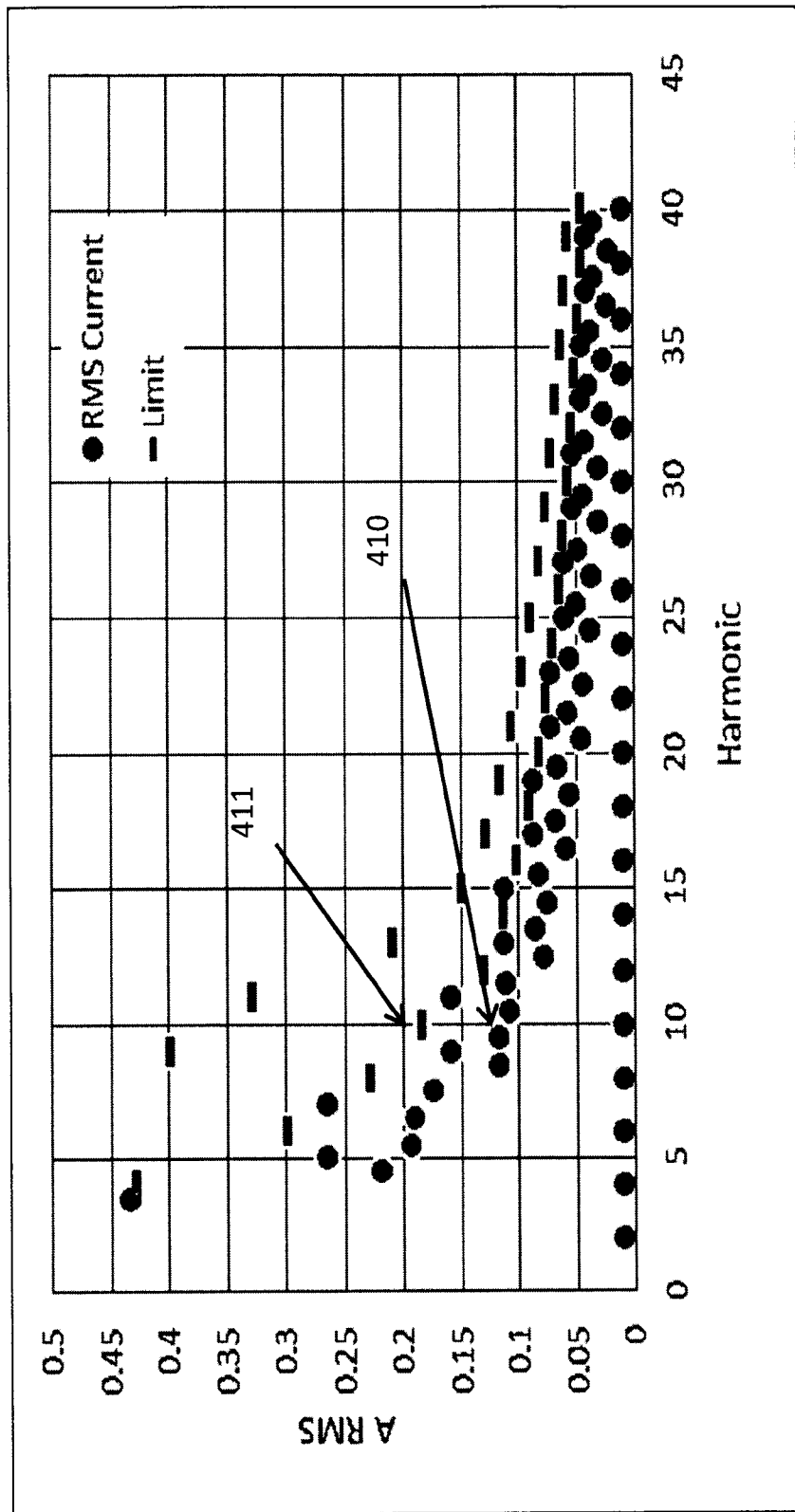

FIG. 5A

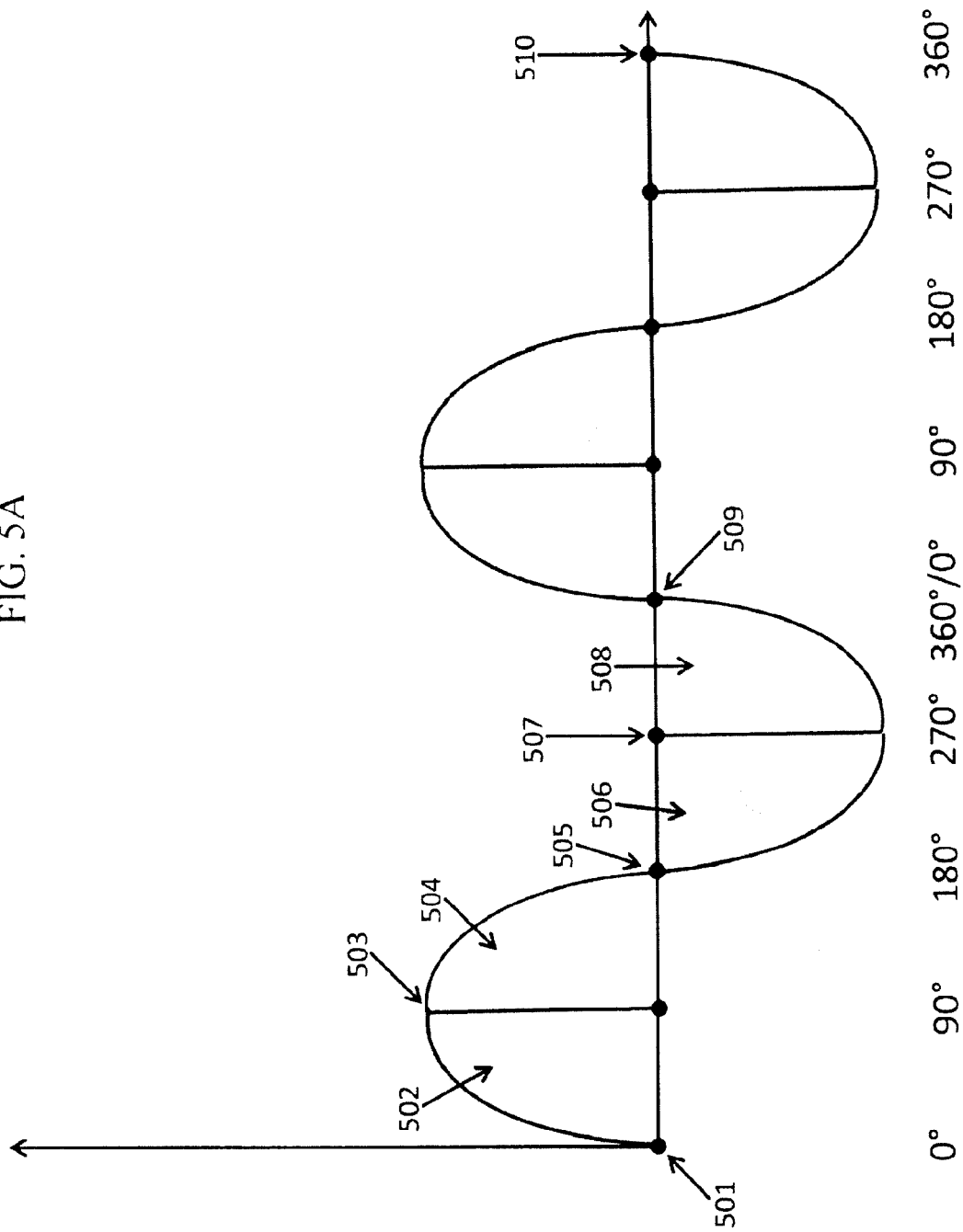

FIG. 5B

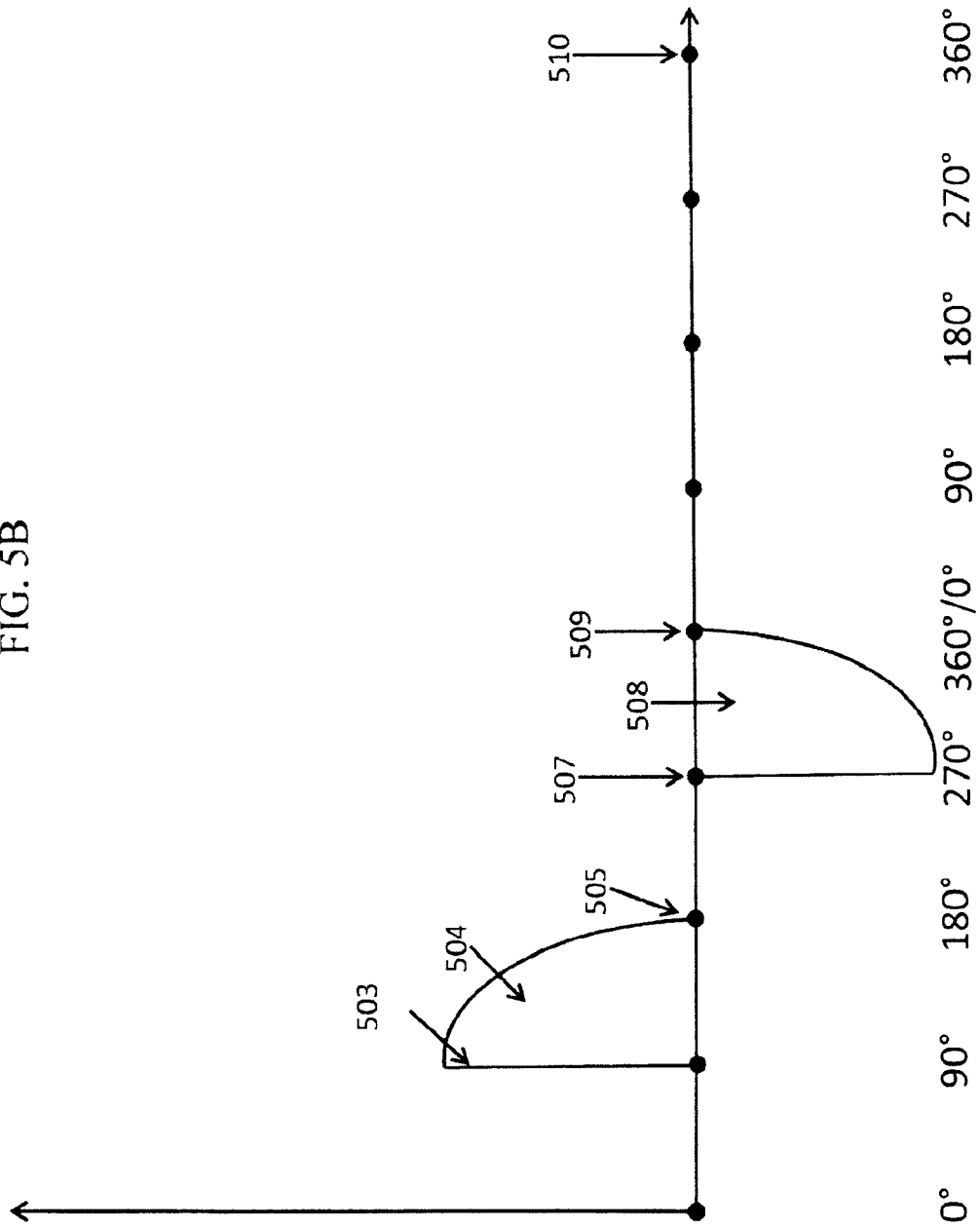

FIG. 5C

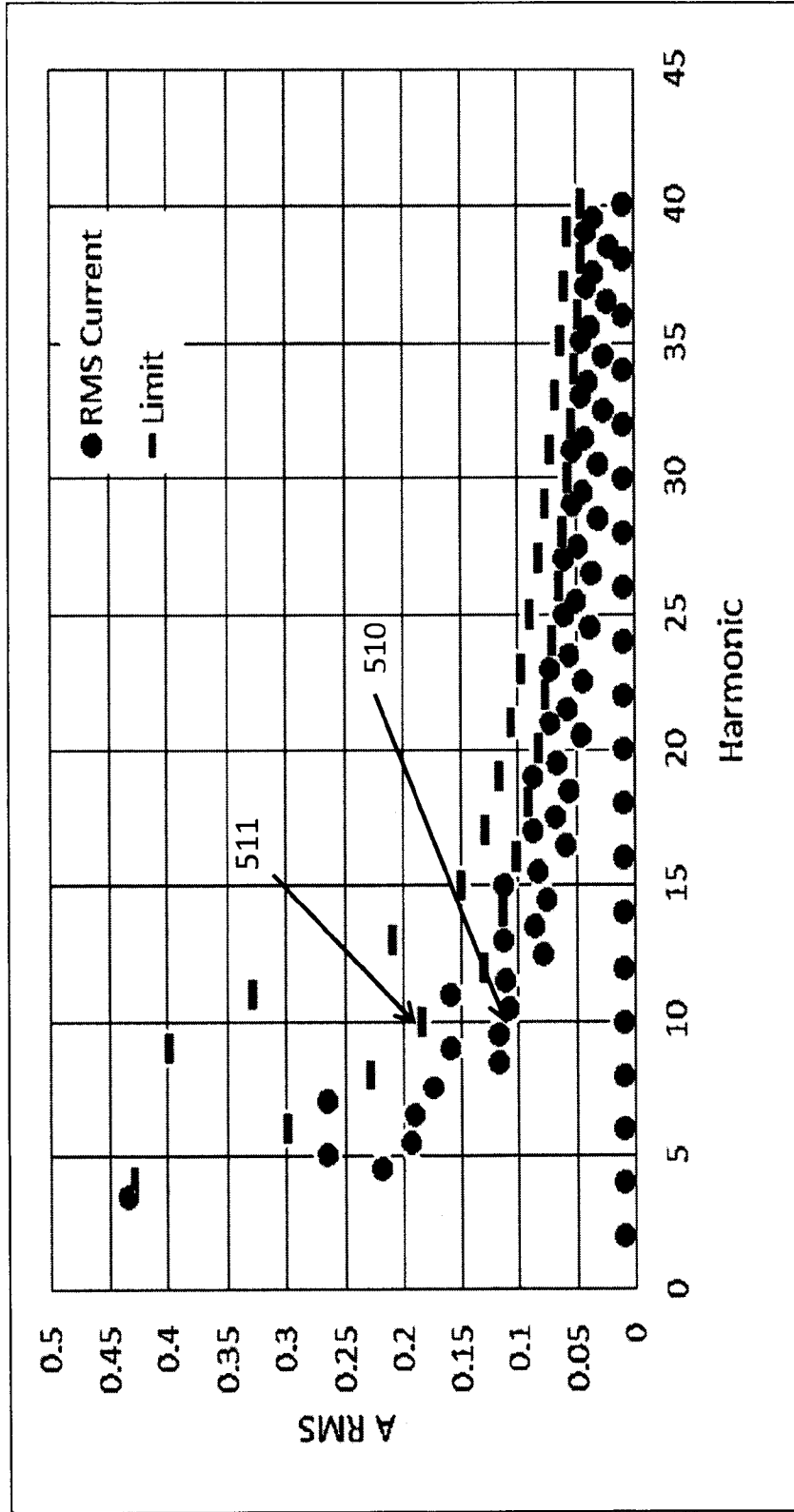

FIG. 6

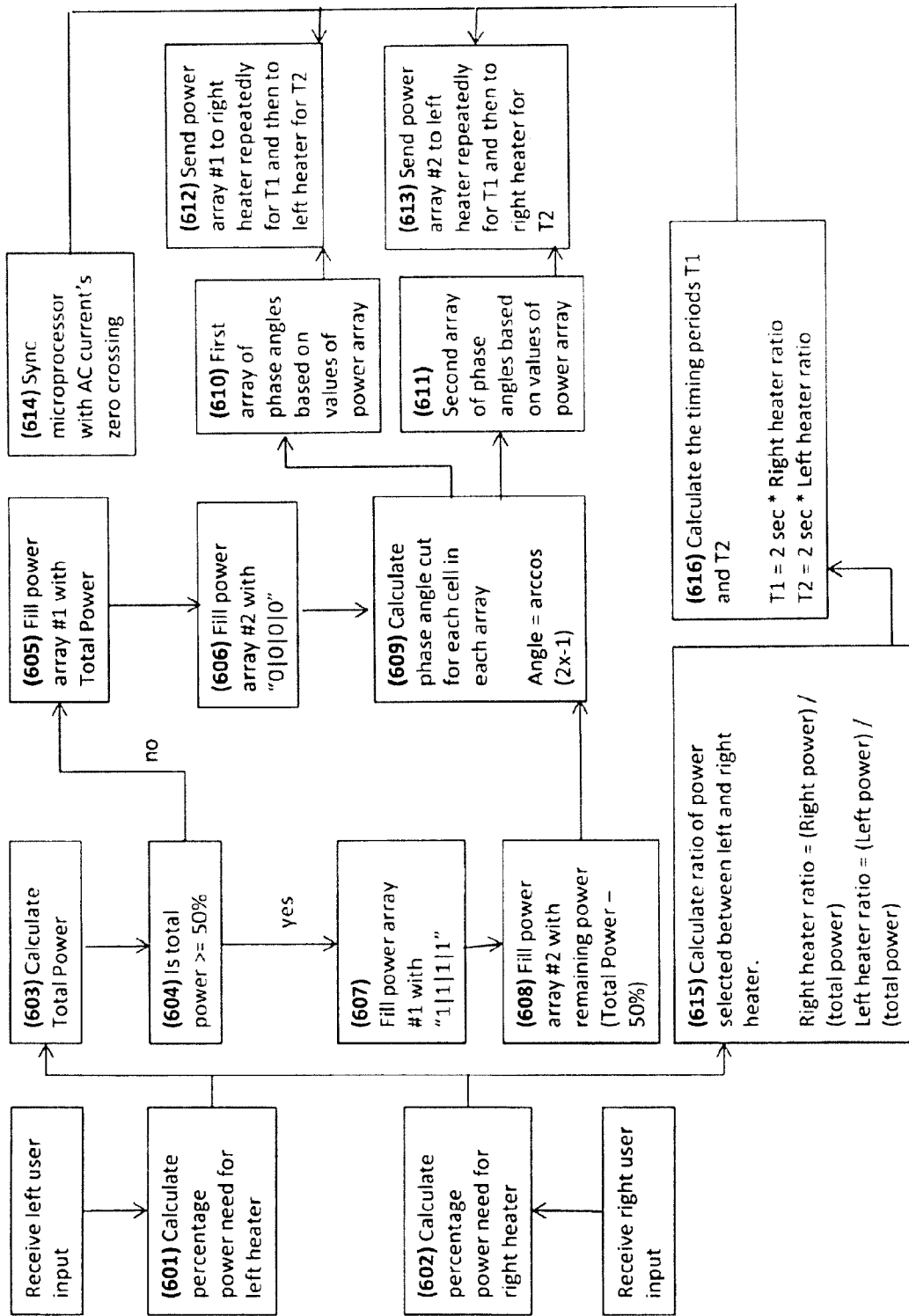

FIG. 7

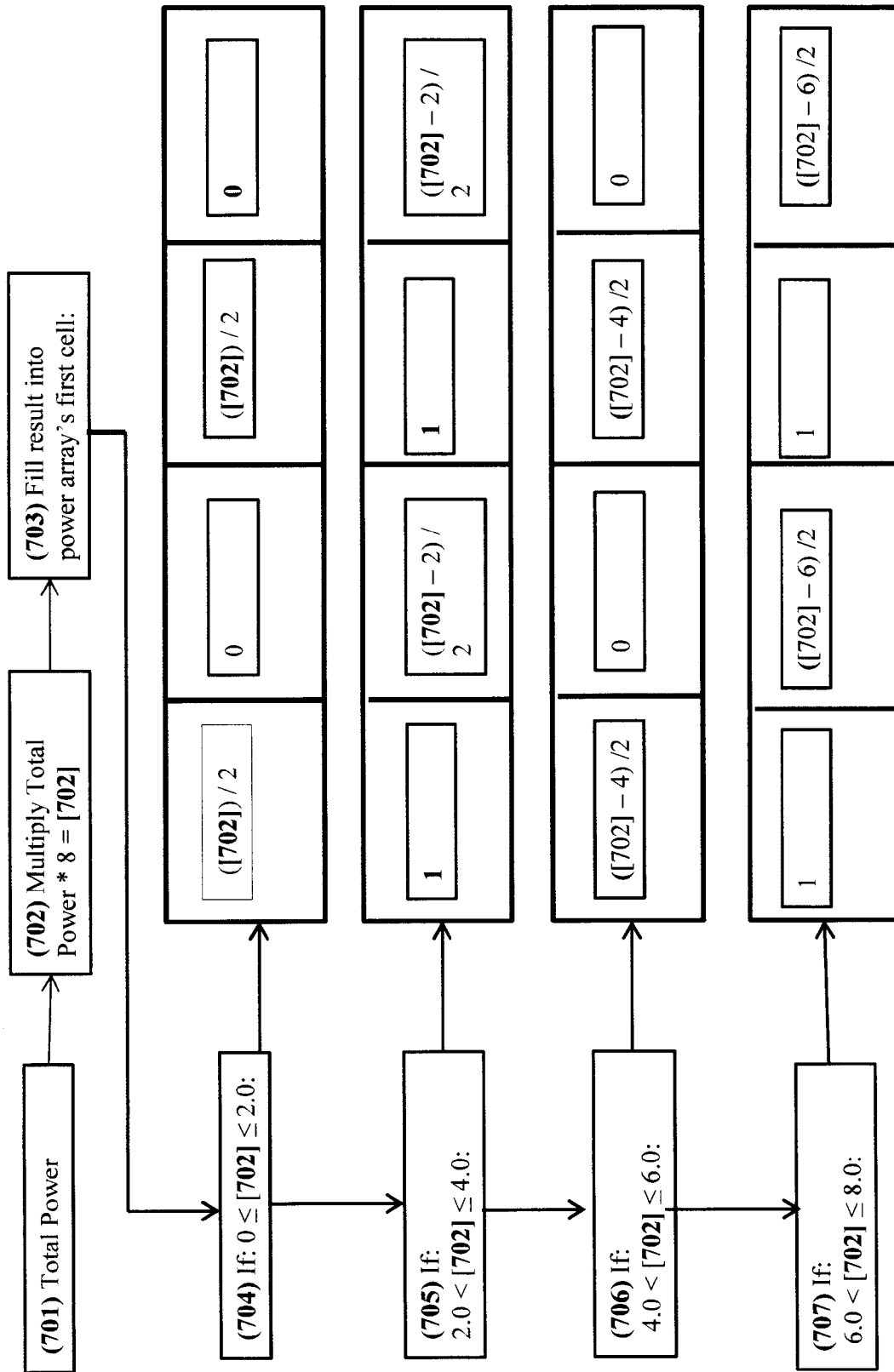
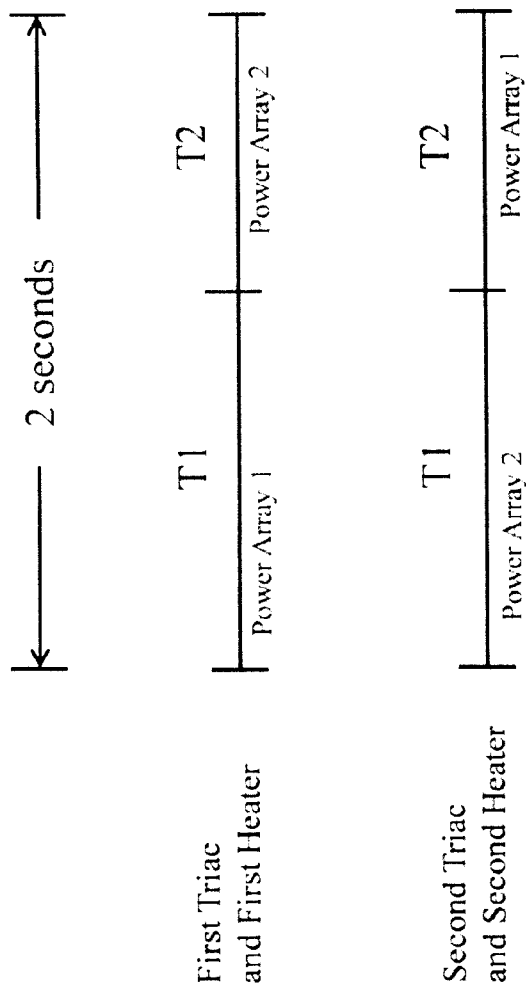
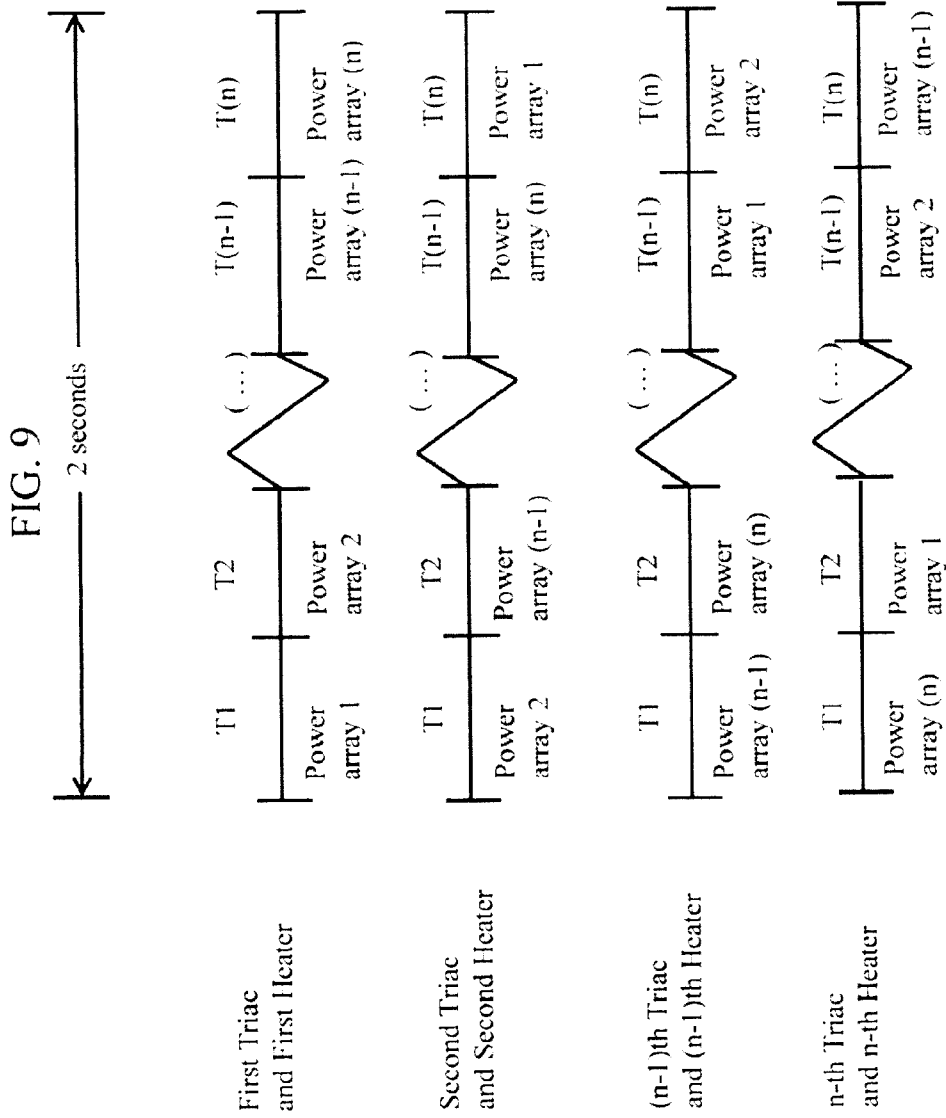

FIG. 8





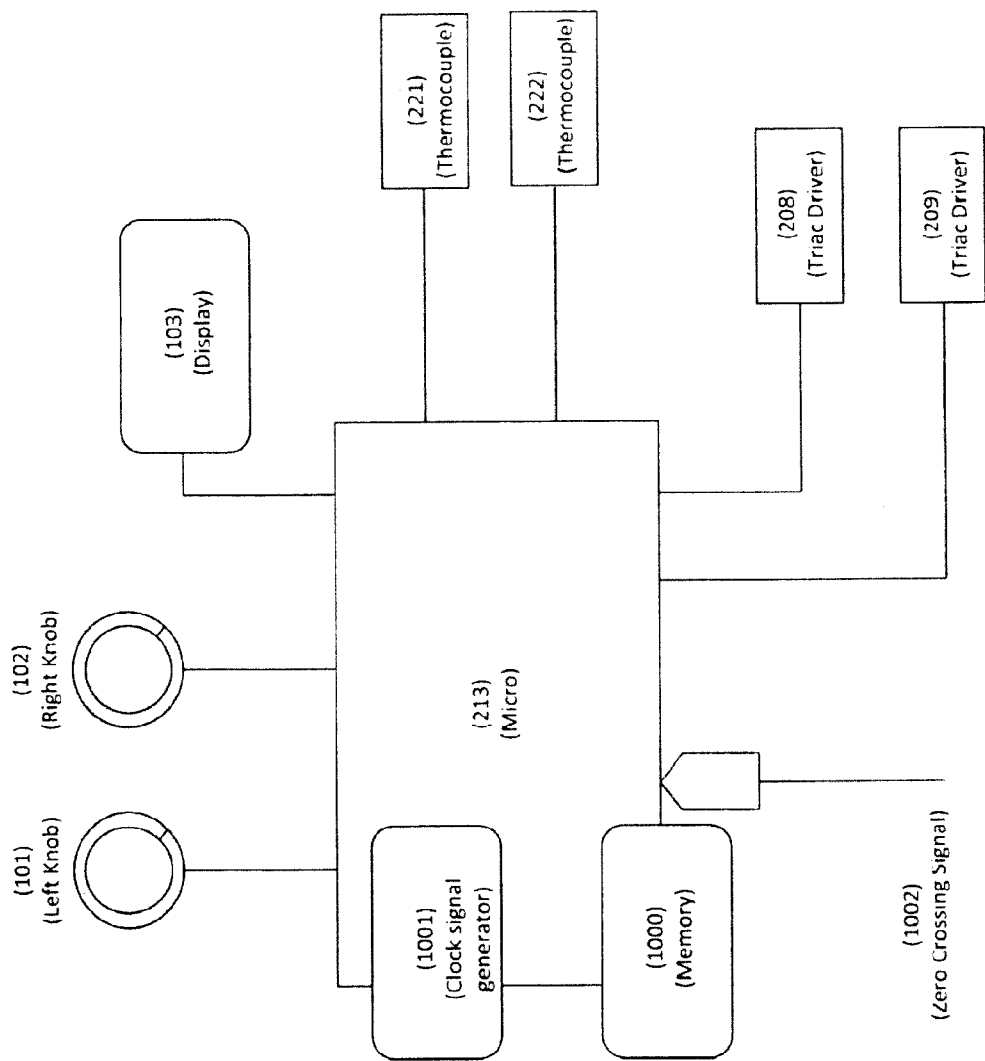
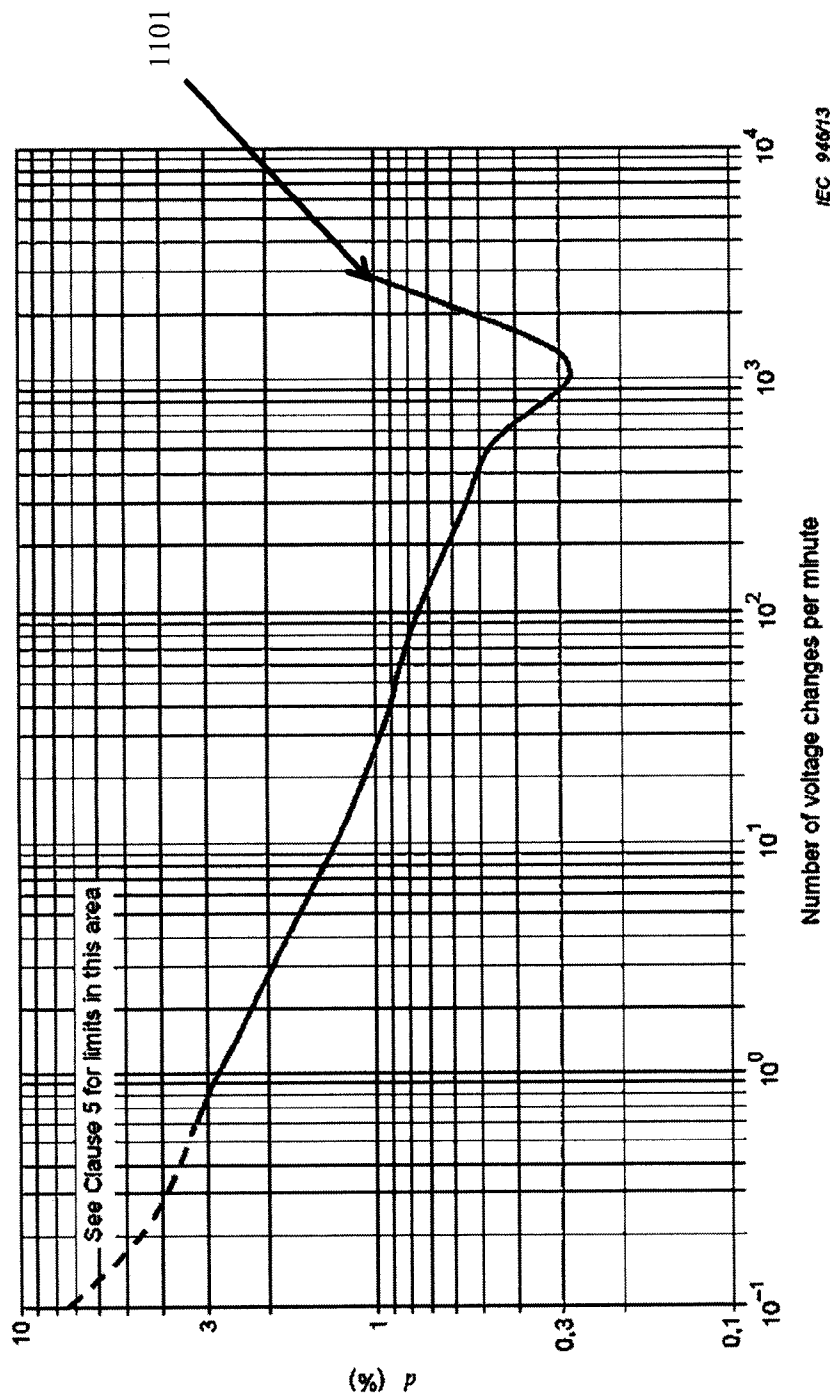

Fig. 10

FIG. 11



NOTE 1 1 200 voltage changes per minute give a 10 Hz flicker.

