



- (51) **International Patent Classification:**
E04H 17/26 (2006.01) A01K 3/00 (2006.01)
- (21) **International Application Number:**
PCT/AU2018/051253
- (22) **International Filing Date:**
23 November 2018 (23.11.2018)
- (25) **Filing Language:** English
- (26) **Publication Language:** English
- (30) **Priority Data:**
2017904755 24 November 2017 (24.11.2017) AU
- (72) **Inventor; and**
- (71) **Applicant: MCKAY, Hugh** [AU/AU]; Jundalee, 1444
Cookardinia Road, Henty, New South Wales 2658 (AU).
- (74) **Agent: FPA PATENT ATTORNEYS PTY LTD;** Level
43, 101 Collins Street, Melbourne, Victoria 3000 (AU).

- (81) **Designated States** (unless otherwise indicated, for every kind of national protection available): AE, AG, AL, AM, AO, AT, AU, AZ, BA, BB, BG, BH, BN, BR, BW, BY, BZ, CA, CH, CL, CN, CO, CR, CU, CZ, DE, DJ, DK, DM, DO, DZ, EC, EE, EG, ES, FI, GB, GD, GE, GH, GM, GT, HN, HR, HU, ID, IL, IN, IR, IS, JO, JP, KE, KG, KH, KN, KP, KR, KW, KZ, LA, LC, LK, LR, LS, LU, LY, MA, MD, ME, MG, MK, MN, MW, MX, MY, MZ, NA, NG, NI, NO, NZ, OM, PA, PE, PG, PH, PL, PT, QA, RO, RS, RU, RW, SA, SC, SD, SE, SG, SK, SL, SM, ST, SV, SY, TH, TJ, TM, TN, TR, TT, TZ, UA, UG, US, UZ, VC, VN, ZA, ZM, ZW.
- (84) **Designated States** (unless otherwise indicated, for every kind of regional protection available): ARIPO (BW, GH, GM, KE, LR, LS, MW, MZ, NA, RW, SD, SL, ST, SZ, TZ, UG, ZM, ZW), Eurasian (AM, AZ, BY, KG, KZ, RU, TJ, TM), European (AL, AT, BE, BG, CH, CY, CZ, DE, DK, EE, ES, FI, FR, GB, GR, HR, HU, IE, IS, IT, LT, LU, LV, MC, MK, MT, NL, NO, PL, PT, RO, RS, SE, SI, SK, SM,

(54) **Title:** FENCING SYSTEM

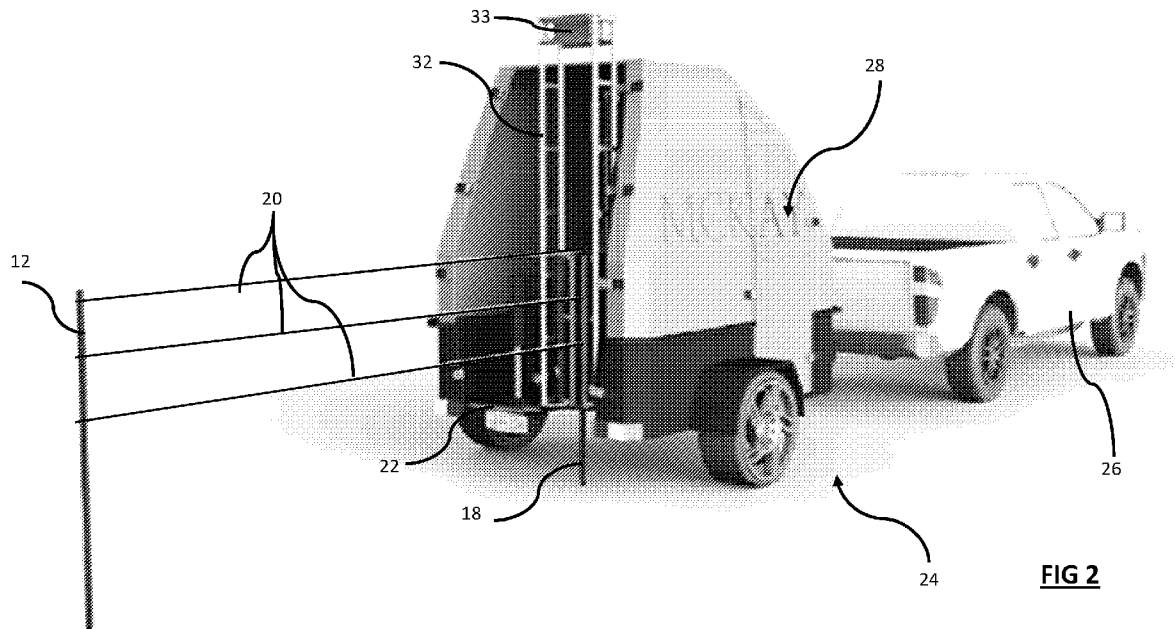

FIG 2

(57) **Abstract:** A fencing system includes a moveable platform capable of being driven independently or towed behind a vehicle. A post driver assembly is mounted to the platform and a post feeding assembly is configured to hold a series of posts and successively feed them into the post driver assembly. The post driver assembly is adapted to drive the successive posts into the ground. At least one wire spool is mounted to the platform and configured to gradually allow wire to feed out of the rear of the platform as the platform is moved forward. The system is adapted to enable the platform to be moved forward and stopped at intermediate distances to drive posts into the ground, with wire being simultaneously fed adjacent the posts or through the posts.



WO 2019/100115 A1

TR), OAPI (BF, BJ, CF, CG, CI, CM, GA, GN, GQ, GW,
KM, ML, MR, NE, SN, TD, TG).

Published:

— *with international search report (Art. 21(3))*

jurisdiction or that this prior art could reasonably be expected to be understood, regarded as relevant, and/or combined with other pieces of prior art by a skilled person in the art.

Summary of the invention

5 According to a first aspect, there is provided a fencing system, including:

a moveable platform, capable of being driven independently or towed behind a vehicle;

a post driver assembly mounted to the platform;

10 a post feeding assembly configured to hold a series of posts and successively feed them into the post driver assembly, the post driver assembly adapted to drive the successive posts into the ground;

at least one wire spool mounted to the platform and configured to gradually allow wire to feed out of the rear of the platform as the platform is moved forward;

15 wherein the system is adapted to enable the platform to be moved forward and stopped at intermediate distances to drive posts into the ground, with wire being simultaneously fed adjacent the posts or through the posts.

The moveable platform may be a trailer or incorporated into a vehicle. The vehicle may be driven by a person or be autonomous. The moveable platform is advantageously covered by a canopy, which may fully house the system components in
20 a storage position for transport and security.

The post driver assembly is preferable a weighted donger, being a moveable weight held within a frame that is dropped from a height onto the top of a post to drive it into the ground. The weight may be returned to its upper position using a drive mechanism, for example a stepper motor and a linear actuator. In an alternative
25 embodiment the post driver assembly may incorporate a hydraulic press or a pneumatic device to pound the post in the ground.

The post feeding assembly may include a conveyor comprising at least one opposing pair of rotational conveyor belts. There may be an upper conveyor belt pair

and a lower conveyor belt pair that guide opposing ends of a post. One of the conveyor belts in a pair may include a series of outwardly extending fingers creating troughs in-between, the other conveyor belt in the pair including peaks and troughs, with opposing troughs between the conveyors being configured to receive a post and guide it along the conveyor system. The fingers are preferably shaped to match the specific post being used. The conveyor belts are preferably inter-changeable, such that conveyor belts can be used that specifically match the post being used for a particular installation.

The post feeding assembly preferably holds at least 20 posts when filled, more preferably 30 or more, most preferably 40 or more; this is dictated by the length of the conveyor and the number of troughs created.

Positioned at the end of the conveyor there may be at least one set of opposing arms to transfer an individual post from the end of the conveyor to a post driving location, and hold it in position whilst being driven into the ground. There may be a set of upper arms and a set of lower arms. An arm may run on a looped track, such that the movement is cyclical to grasp a post between two arms, move forward to transfer the post to the driving position, then move in opposing directions to release the post, move backwards to the end of the conveyor and move towards each other to grasp another post; this cycle is continuously repeated.

The post driver assembly and the post feeding assembly can both be seated on a single floor plate. The floor plate may be slidable sideways in both directions to enable alignment with the desired post location.

The floor plate, whether holding just the post driver assembly alone or in combination with the post feeding assembly, may have the ability to be stabilised so that when the platform is positioned on a sloping ground, the post driver assembly can be adjusted to drive the post into a substantially vertical orientation when desired, or within a predetermined set of directional parameters. This may be accomplished with the integration of three linear actuators connected to the platform via an actuated universal joint, multiple pivot joint, etc.

One or more wire spools may be configured to be held on a single spindle. The spindle may be mounted to the platform. The wire may be threaded from the spool

adjacent the post driver assembly, through the post driver assembly, or through holes in the posts held in the conveyor.

The spindle may be configured to tilt sideways from the platform to allow reloading of wire spools onto the spindle. In an embodiment, the wire from a lowermost
5 wire spool may be fed through an opening in the bottom of the platform to a guide held underneath, positioning a wire near the ground for subsequent attachment to posts.

Advantageously, the system is automated, such that sensors and accelerometers are integrated into the system to determine positioning of posts and components of the system, processors are used to determine the required locations of components and
10 speed of motors etc, and controllers are used to activate and stop components of the system.

According to a second aspect, there is provided a method for installing a fence on a property, including:

- providing and activating a GPS base unit;
- 15 attaching a GPS rover unit to a fencing system according to the first aspect;
- installing strainer posts at desired locations on the property;
- determining the GPS locations of two spaced apart strainer posts;
- calculating the number of intermediate posts required between the two strainer posts and their desired GPS location;
- 20 positioning the moveable platform with respect to a first strainer post;
- attaching the end(s) of the wire to the first strainer post;
- advancing the moveable platform to the first and subsequent intermediate post locations and driving posts into the ground at the calculated desired GPS locations.

Advantageously, the advancing of the moveable platform to the desired GPS
25 locations can be autonomously controlled. Alternatively, the GPS location information

can be sent to a driver on board display to notify the driver of any adjustments needed to the positioning of the platform and/or post feeding assembly.

According to a third aspect, there is provided a self-levelling post driver system, including:

- 5 a frame for holding a post in a desired position;
- a post driver assembly mounted within the frame;
- an accelerometer for determining the position of the frame relative to vertical;
- a plurality of adjustable legs capable of independent adjustment in order to position the post held in the frame in a predetermined orientation relative to the ground;
- 10 a processor and controller for independent adjustment of the legs.

The post driver assembly may be seated on a floor plate. The adjustable legs may be linear actuators connected to the floor plate via an actuated universal joint, multiple pivot joint, etc. There is preferably three linear actuators.

- 15 The floor plate may also be slidable sideways in both directions to enable alignment with the desired post location.

According to a fourth aspect, there is provided an automatic post driver system, including:

- a frame for holding a post in a desired position;
- a weight moveable held within the frame adapted to contact the top of the post
20 and drive the post into the ground;
- means to move the weight within the frame;
- sensors to determine the height of the top of the post above the ground;
- a processor for determining the height that the weight is required to be dropped from to achieve the force require to drive the post to a predetermined height above the
25 ground; and

a controller for actuating the means to move the weight and releasing the weight to drive the post into the ground.

Brief description of the drawings

Further aspects of the present invention and further embodiments of the aspects
5 described in the preceding paragraphs will become apparent from the following description, given by way of example and with reference to the accompanying drawings, in which:

FIG 1a is a representative front view of a fence;

FIG 1b is a representative top view of a property with a bordering fence;

10 FIG 2 is a perspective view of the fencing system according to an embodiment;

FIG 3a is a side view of the fencing system of FIG 2 with the side of the trailer removed, with the post driver frame positioned in a transport position;

FIG 3b shows the system of FIG 4a, with the post driver frame in the in-use position;

15 FIG 4 is a top view of the fencing system of FIG 2 with trailer panels shown exploded;

FIG 5 is a perspective view of the post driver frame and post feeding frame;

FIGs 6a through 6C illustrate the post feeding assembly being loaded with posts;

20 FIG 7 is a perspective view of the fencing system of FIG 2, with an alternative trailer design, showing the loading of the feeding assembly;

FIGs 8a through 8d are top sectional views, illustrating the transferring of the post from the post feeding assembly to the post driver assembly;

FIG 9a is a perspective view of the fencing system of FIG 7, with the post driver weight in the upper position;

FIG 9b shows the system of FIG 9a, with the post driver weight in the lower position;

FIGs 10a through 10c show the post driver assembly and post feeding assembly being stabilised;

5 FIGs 11a and 11b show the sideways adjustment of the post driver assembly and post feeding assembly;

FIG 12 shows a guide system for attaching the wires to the post of FIGs 11a and 11b; and

FIG 13 shows the fencing system of FIG 2 and a GPS base station.

10 **Detailed description of the embodiments**

The present invention relates to the installation of a fence 10, similar to that shown in FIG 1a. Strainer assemblies 12 are located at each end of a long section of fence. The main role of the strainer assembly is to be able to structurally hold the force of the strained up wires and netting of the fence. Strainer assemblies will be found at
15 the beginning and end of the fence, anywhere there is a major change in direction or topography, as well as a sturdy structure in which to attach a gate to. In fences that range over a severe distance you will find strainer assemblies in the middle to help strengthen the fence line. An example property is shown in FIG 1b, where five strainer assemblies 12 are positioned around the border of a paddock 16. The fences may be
20 providing the property border next to a road 14 or may be dividing paddocks 16.

Intermediate posts 18 in a fence sit at regular intervals between the strainer assemblies 12, as shown in FIG 1a. The main purpose is to guide the wires 20 and netting, as well as providing a smaller amount of structural support.

The number of intermediate posts 18 will be determined by the distance between
25 strainer assemblies 12, as well as a desired distance between posts. The desired distance between posts will depend on its purpose and mainly the livestock type and predicted pressure it is required to hold. Whilst less posts makes for an easier and cheaper fence installation, if spacing is too large the pressure is not distributed across multiple posts and breakages are more likely to occur.

The three main forms of wires used in fencing are prefabricated rolls, plain wire and barbed wire. Wires come in many different thicknesses also known as gauges and tensile strengths depending on its purpose. The spacing between wires is also important, as smaller animals will require smaller gaps. There may also be a need to
5 integrate barbed wire or electric wire into the fence.

One embodiment of the present invention is directed to a system for the installation of intermediate posts 18 and wires 20 between strainer assemblies 12. However it will be appreciated that the present invention could also be adapted to drive in the strainer assemblies. A movable platform 22 integrated into a trailer 24 is towed
10 behind a vehicle 26, although it will be appreciated that the movable platform may be integrated directly into a vehicle. As shown in FIG 2, the trailer may be made up of a steel bottom tray 22 and a rotary moulded exterior cover or canopy 28, made for example from polyethylene. There may be removable access covers, which may be in the form of doors 30 that provide access to the rear, top and sides of the canopy.

Mounted to the platform 22 is a post driver assembly. In the embodiment shown the assembly comprises an upright frame 32 and a weight 33 that moves within the frame on rollers. The frame 32 is pivotally mounted to the platform 22, allowing it to be lowered within the trailer canopy 28 for road transport, as shown in FIG 3a. Once on a property, the frame is pivoted into an upright orientation and locked into position, as
20 shown in FIG 3b.

As shown in FIGs 3a to 4, positioned in front of the post driver frame 32 is a post feeding assembly 34, which can be pre-loaded with a plurality of intermediate posts 18, to be described further below. Both the post driver frame 32 and the post feeding assembly 34 are seated on a metal plate 36 (FIG 4).

Towards the front of the trailer is spindle 38 that receives wire spools 40 that are wound with wires 20. The spindle is configured to tilt sideways from the platform to allow reloading of wire spools onto the spindle.

Also at the front of the trailer is a generator 42 for powering the system. It will be appreciated that batteries may also be utilised instead of the generator.

FIG 5 shows the combination of the upright frame 32 together with the post feeding frame 44 and an intermediate post transfer frame 46. The frame of this illustrated embodiment is constructed by welding structural steel tube (typically RHS) together to form guide rails for the moveable parts. As can be seen in FIG 5, the upright frame 32 is wider than the other frame sections, enabling it to pivot downwards over the top of the other frame sections to lie flat on the trailer floor, as shown in FIG 3a. Upright frame 32 also partially or fully sits over post transfer frame 46.

FIGs 6a through 6d show the loading of the feeding assembly 34. The feeding assembly includes a conveyor that has rotating conveyor belts 48. Four conveyor belts 48 are used, two upper belts being a left upper belt 48a and a right upper belt 48b and two lower belts being a left lower belt 48c and a right lower belt 48d. The belts 48 rotate around sleeves 51 that are fitted to the upright frame sections 50 at the front end and stepper motors 52 mounted on pads 54 at the rear end. The conveyor belts are typically made of rubber and a left and right pair work together to guide the posts 18. The left belts 48a, 48c include a series of outwardly extending fingers 56 with troughs 58 in between. The right belts 48b, 48d include a series of peaks 60 and troughs 62. This conveyor belt profile is specifically designed to accommodate a 3-point star picket post. The belts are removable so that they can be interchanged for belts specifically designed for the posts being used for a particular fence installation. As can be seen, the conveyor belts are adjacent each other on the inside of the frame 44, with opposing troughs 58, 62 creating a void shaped to receive the star picket post. Cooperative rotation of the conveyor belts transfers the posts 18 to the post driver assembly. Posts 18 are introduced from the front end of the frame 44 (see FIGs 6a, 6b) and are conveyed along the conveyor (FIG 6c) to the rear end (FIG 6d). The feeding assembly can be pre-loaded with posts before commencing the construction of a fence, with the stepper motors being stopped until the system is ready to be used. Loading of the posts 18 can be done via side access to the trailer, as shown in FIG 7. The feeding mechanism illustrated can hold 30 posts. However it will be appreciated that lengthening of the conveyor would enable the system to hold more posts.

At the end of the conveyor is the post transfer frame 46. The frame 46 creates tracks 64, being rectangular loops. Opposing arms 66 are mounted on respective tracks, with an upper pair of arms 66a and a lower pair of arms 66b being provided to

grasp the post 18 as it exits the conveyor. As shown in FIG 8a, the two arms 66a move towards each other to grasp the post 18. The arms move along the track rearwardly to position it underneath the post driver (FIG 8b). The post is driven into the ground (as described below) and the arms move away from each other to release the post (FIG 5 8c). They return to their original position (FIG 8d) by sliding forwards along the track, ready to move together again to grasp a subsequent post.

The post driver assembly illustrated is a weighted donger, whereby a weight 33 runs along tracks created by frame 34. The weight 33 is dropped from a predetermined height (FIG 9a) to create a force on the top of the post sufficient to drive it into the 10 ground (FIG 9b). It will be appreciated that the weight may need to be dropped several times to drive the post into the ground sufficiently to obtain the desired height. Whilst the initial impact may be created from dropping the weight from maximum height, subsequent drops may be from a lesser height if a smaller impact is required to achieve the desired height. The weight can be moved upwards by a linear actuator for example.

15 As an alternative to a weighted donger, a non-illustrated embodiment could incorporate a post driver assembly that utilises a hydraulic press or a pneumatic drive to pound the post into the ground. A person skilled in the art will appreciate how these drivers can be incorporated into the system.

The process for installing the fence begins by positioning the rear of the trailer 20 adjacent a strainer post 12. The ends of the wires 20 are attached to the strainer post 12 at the desired heights. This may include a wire 20a close to the ground, which would be guided underneath the trailer via an underlying guide and reel.

The trailer is then advanced forward to the location of the first intermediate post 18. As the trailer advances, the wires 20 spool out of the rear of the trailer. The wire 20 25 in the illustrated embodiment runs adjacent the frame 32. However, it will be appreciated that in other embodiments the wire may run through the frames or have been threaded through apertures in the posts 18 whilst held within the conveyor. Advantageously each wire coil on the wire spinner, could be controlled by an individual high torque stepper motor, which will both allow for the wires to be spun out at an 30 accurate timing and distance, but also help in straining the fence at the end of the run.

The wire coils could rotate, tightening and tensioning the wires to a desired tension allowing for an easier straining of the fence.

When the trailer is in the desired location, it is stopped, the arms 66 grasp a post 18 from the end of the conveyor and position it in the frame 32 under the weight 33. The weight is dropped onto the top of the post and the post is driven into the ground. The trailer is then advanced again to the desired location of the next post 18 and the process is repeated. The process is continuously repeated until the trailer reaches the next strainer post 12.

In most instances where the trailer is situated on uneven or sloping ground, it is still desired that the post 18 is driven into the ground in a vertical or near vertical orientation. To enable this, the post driver assembly and the post feeder assembly are seated on common floor plate 36. The plate 36 has the ability to be stabilised in a horizontal orientation. This is achieved by three linear actuators 70 statically connected to the moveable platform 22, with arms 72 mounted to the plate 36 via universal joints 74. The three actuators are configured in a triangle (see FIG 4) to allow full freedom of movement of the plate 36 to achieve the desired orientation, as shown in FIGs 10a through 10c. The actuators are controlled by stepper motors.

There may also be instances where the trailer is not correctly aligned with the fence line. This may be due to the presence of rocks etc. The plate 36 is therefore also capable of sideways movement by sliding on tracks using linear actuators (not shown), as represented in FIGS 11a, 11b. Around 500mm of lateral movement could be accommodated.

The present invention can be used with a variety of types of posts, with many of the posts requiring a subsequent step of attaching the wire that is sitting adjacent the posts to the posts. This may be a manual task that is performed as the vehicle is advancing or subsequent to installation of an entire fence section. This may typically be a manual process.

Advantageously, the system would be used with a post that enables quick connection of the wires. For example, there have been posts developed that include an

L-shaped slot, with a rotational clip that locks the wire into the slot. Such a post is the Clipex® post.

To automate the connection of the wires to the Clipex® post, a guide 76 can be used (see FIG 12) that is connected to the platform 22 via actuators (not shown). It can
5 be moved towards the fence post to push the wires into the slots and then moved downwards to rotate the clips, locking the wires to the post.

When the end of the fence is installed, the wire spinner may automatically tension the wire and then it can be held and tied off.

In some embodiments, the system is automated, such that there are sensors and
10 accelerometers that determine the positioning of posts and components of the system and controllers that move the components when needed and turn motors on and off. Processors are used to determine the speed of motors, the required locations of components and the system may also advance automatically itself to the next desired post location.

15 In particular, the post driver assembly may be automated. In some embodiments, the post driver assembly may be provided as a separate assembly that may be used independent of the system and trailer.

The post driver assembly may incorporate a gyroscope and accelerometer. In some embodiments, these may be positioned on the feeding assembly. Using
20 information from the gyroscope, the linear actuators 70 can be actuated to control the angle of the plate 36.

According to one embodiment, real time kinematic (RTK) satellite navigation is used with GPS tracking. An RTK base station 78 (see FIG 13) will be positioned on the property to improve the accuracy of the GPS tracking. The base station can be set up at
25 the beginning of the day and left in the one spot, provided the trailer does not leave a 10km radius.

A rover unit 80 can be positioned on the strainers 12 to determine their location. A processor, which may be integrated into an application on a smart device, can work out the required distance of the fence to be built, the required amount of materials and

the distance between each post. GPS coordinates for the intermediate posts 18 are calculated and stored. A rover unit 80 can be attached to the trailer, typically to the frame 32. The post location information is then either communicated to the driver of the vehicle, including when the desired post locations are reached, or the movement of the
5 vehicle can be automated.

The present invention provides a system for installing fencing that requires minimal labour and increases the speed of installation. An average contractor will complete 200 metre of fencing on a good day (not including insertion of strainer posts). It is expected that the present invention would be able to complete up to 40km of
10 fencing in one day.

It will be understood that the invention disclosed and defined in this specification extends to all alternative combinations of two or more of the individual features mentioned or evident from the text or drawings. All of these different combinations constitute various alternative aspects of the invention.

CLAIMS

1. A fencing system, including:

a moveable platform, capable of being driven independently or towed behind a vehicle;

5 a post driver assembly mounted to the platform;

a post feeding assembly configured to hold a series of posts and successively feed them into the post driver assembly, the post driver assembly adapted to drive the successive posts into the ground;

10 at least one wire spool mounted to the platform and configured to gradually allow wire to feed out of the rear of the platform as the platform is moved forward;

wherein the system is adapted to enable the platform to be moved forward and stopped at intermediate distances to drive posts into the ground, with wire being simultaneously fed adjacent the posts or through the posts.

15 2. A fencing system according to claim 1, wherein the moveable platform is covered by a canopy such that the system components are fully housed in a storage position for transport and security.

3. A fencing system according to claim 1 or 2, wherein the post feeding assembly includes a conveyor comprising at least one opposing pair of rotational conveyor belts.

20 4. A fencing system according to claim 3, wherein there is an upper conveyor belt pair and a lower conveyor belt pair that guide opposing ends of a post.

25 5. A fencing system according to claim 3 or 4, wherein one of the conveyor belts in a pair includes a series of outwardly extending fingers creating troughs in-between, the other conveyor belt in the pair including peaks and troughs, with opposing troughs between the conveyors being configured to receive a post and guide it along the conveyor system.

6. A fencing system according to any one of claims 3 to 5, wherein the conveyor belts are inter-changeable, such that conveyor belts can be used that specifically match the post being used for a particular installation.
7. A fencing system according to any one of the preceding claims, wherein the post feeding assembly holds at least 20 posts when filled, more preferably 30 or more, most preferably 40.
8. A fencing system according to any one of claims 3 to 6, wherein positioned at the end of the conveyor there is at least one set of opposing arms to transfer an individual post from the end of the conveyor to a post driving location, and hold it in position whilst being driven into the ground.
9. A fencing system according to claim 8, wherein the arms run on looped tracks, such that the movement is cyclical to grasp a post between two arms, move forward to transfer the post to the driving position, then move in opposing directions to release the post, move backwards to the end of the conveyor and move towards each other to grasp another post.
10. A fencing system according to any one of the preceding claims, wherein the post driver assembly and/or the post feeding assembly are seated on a floor plate, the floor plate being slidable sideways in both directions to enable alignment with a desired post location.
11. A fencing system according to any one of the preceding claims, wherein a floor plate holding at least the post driver assembly is provided which is configured to be stabilised so that when the platform is positioned on a sloping ground, the post driver assembly can be adjusted to drive the post into a substantially vertical orientation when desired, or within a predetermined set of directional parameters.
12. A fencing system according to any one of the preceding claims, wherein, the system is automated, such that sensors and accelerometers are integrated into the system to determine positioning of posts and components of the system, processors are used to determine the required locations of components and speed of motors etc, and controllers are used to activate and stop components of the system.

13. A method for installing a fence on a property, including:
- providing and activating a GPS base unit;
 - attaching a GPS rover unit to a fencing system according to any one of claims 1 to 12;
- 5 installing strainer posts at desired locations on the property;
- determining the GPS locations of two spaced apart strainer posts;
 - calculating the number of intermediate posts required between the two strainer posts and their desired GPS location;
 - positioning the moveable platform with respect to a first strainer post;
- 10 attaching the end(s) of the wire to the first strainer post;
- advancing the moveable platform to the first and subsequent intermediate post locations and driving posts into the ground at the calculated desired GPS locations.
14. A self-levelling post driver system, including:
- a frame for holding a post in a desired position;
- 15 a post driver assembly mounted within the frame;
- an accelerometer for determining the position of the frame relative to vertical;
 - a plurality of adjustable legs capable of independent adjustment in order to position the post held in the frame in a predetermined orientation relative to the ground;
 - a processor and controller for independent adjustment of the legs.
- 20 15. A system according to claim 14, wherein the post driver assembly is seated on a floor plate and the adjustable legs are linear actuators connected to the floor plate via an actuated universal joint.

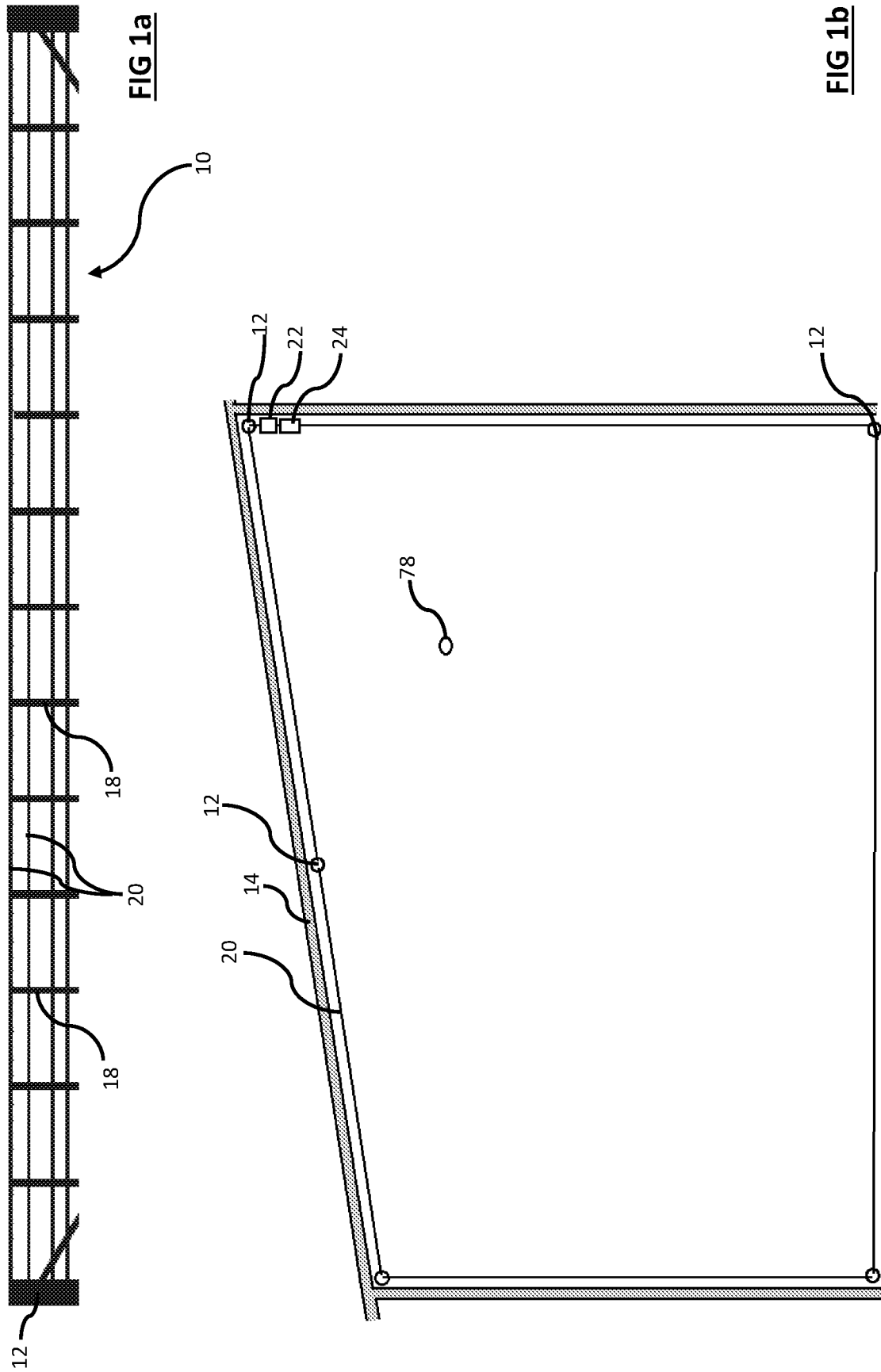

FIG 1b

FIG 1a

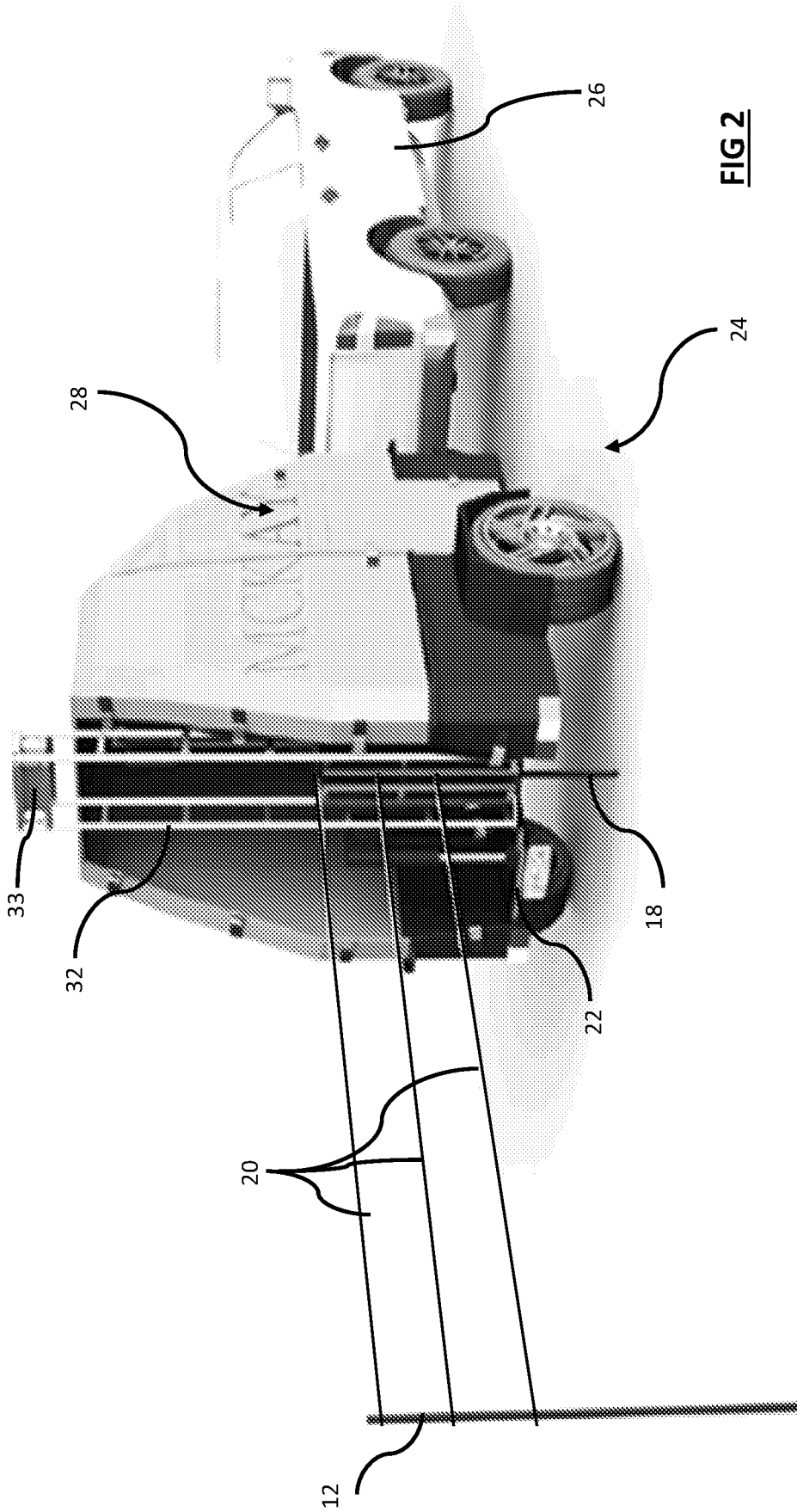

FIG 2

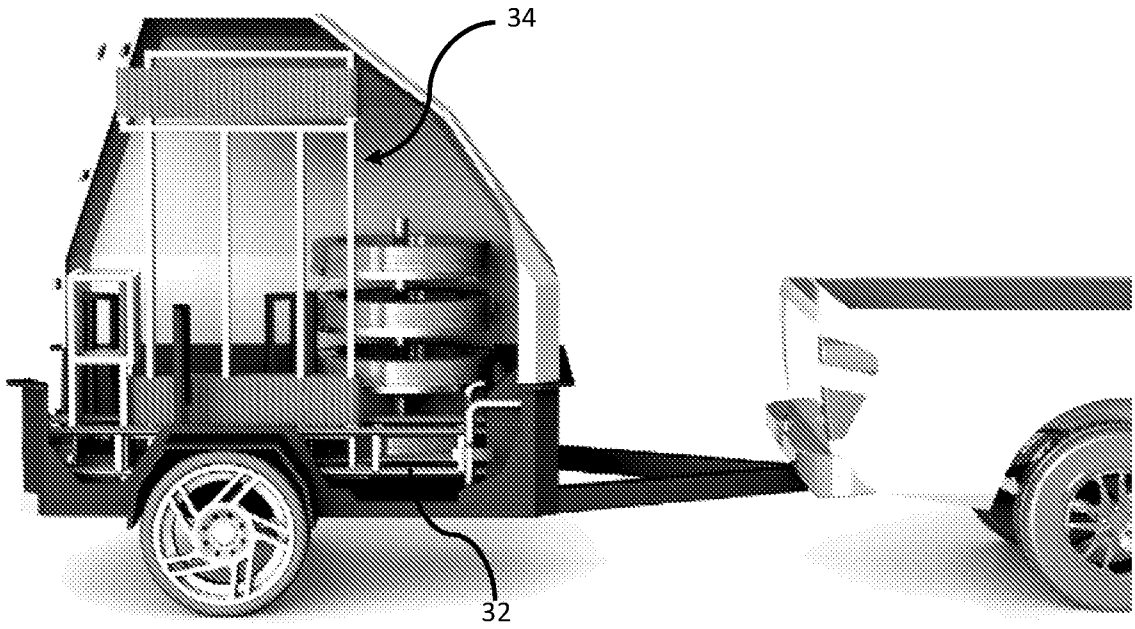

FIG 3a

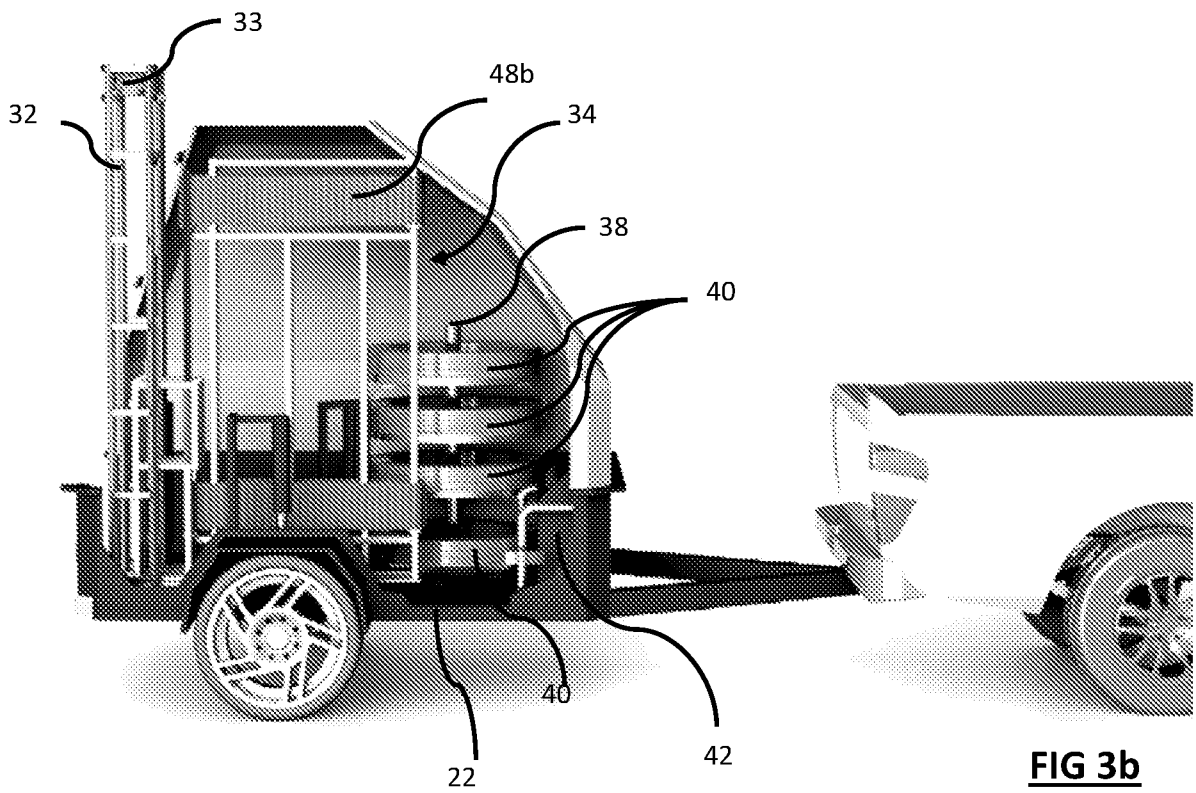

FIG 3b

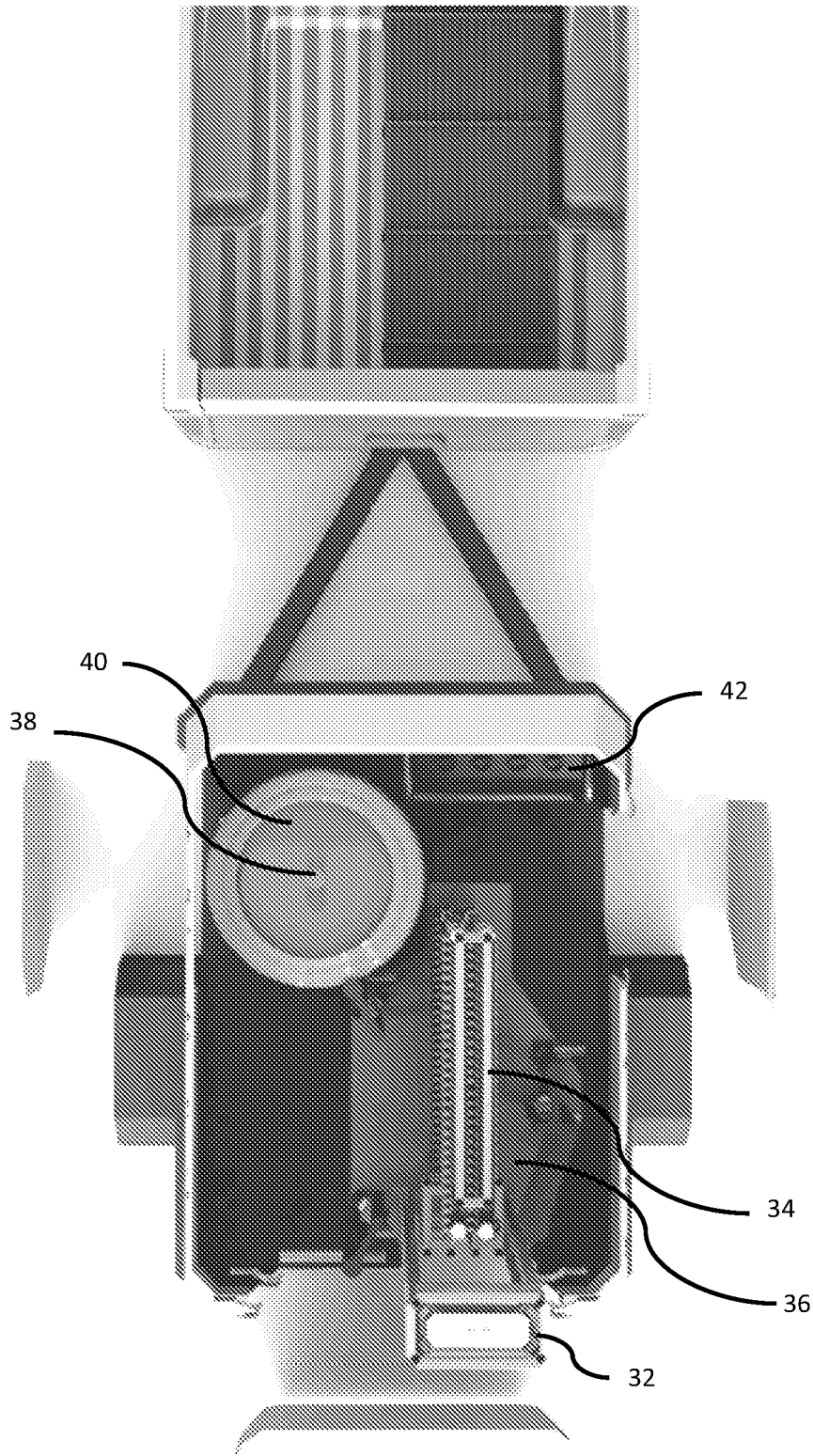

FIG 4

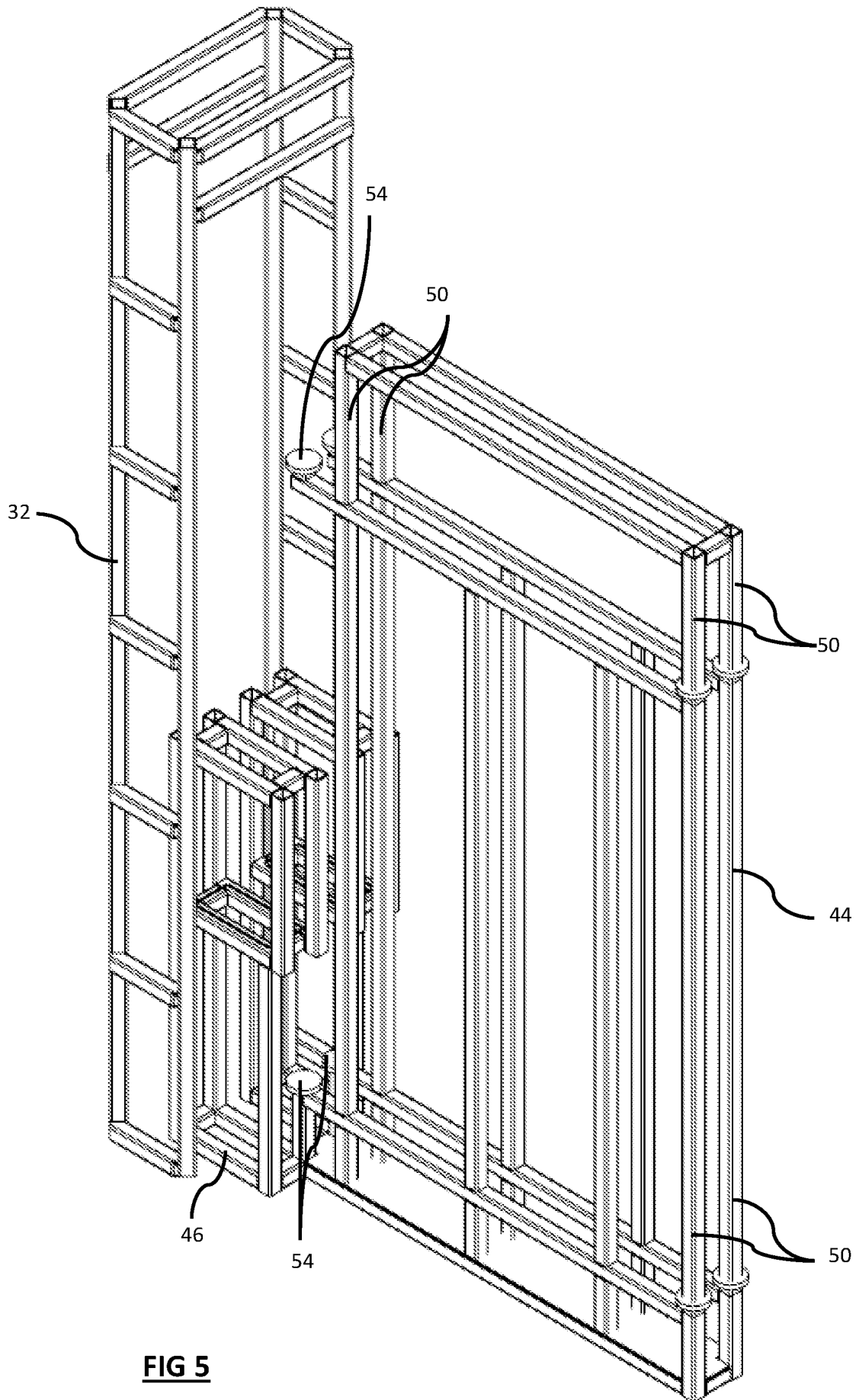

FIG 5

6/13

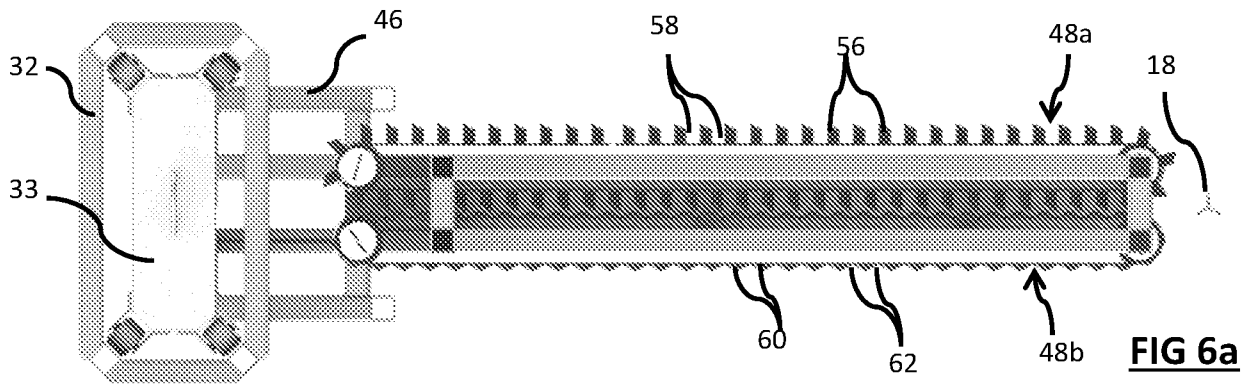

FIG 6a

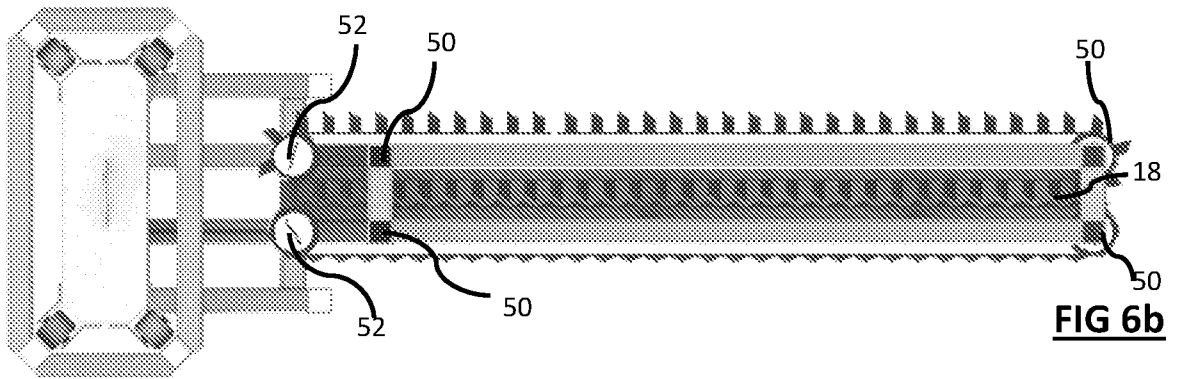

FIG 6b

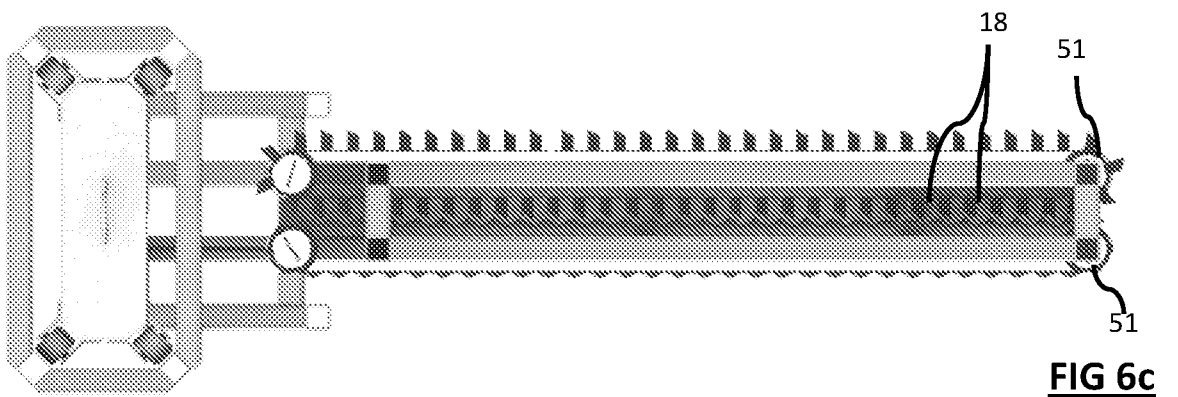

FIG 6c

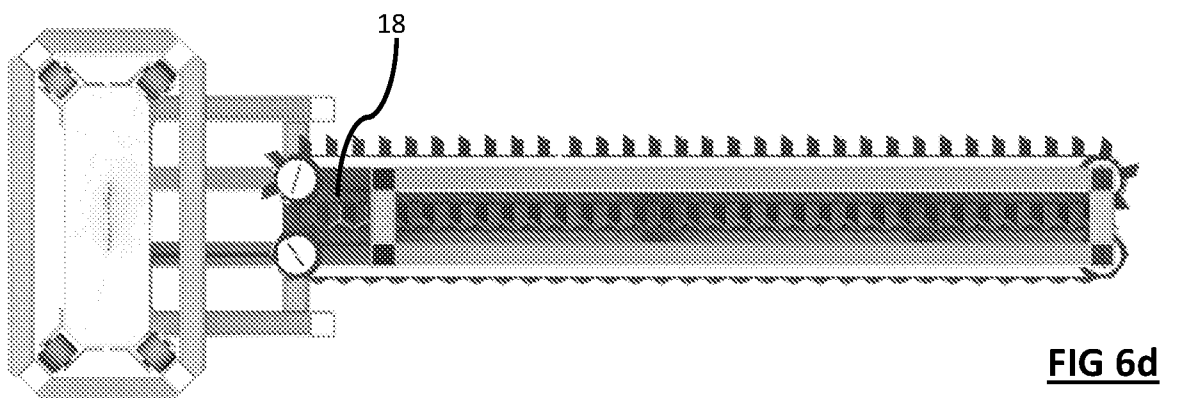

FIG 6d

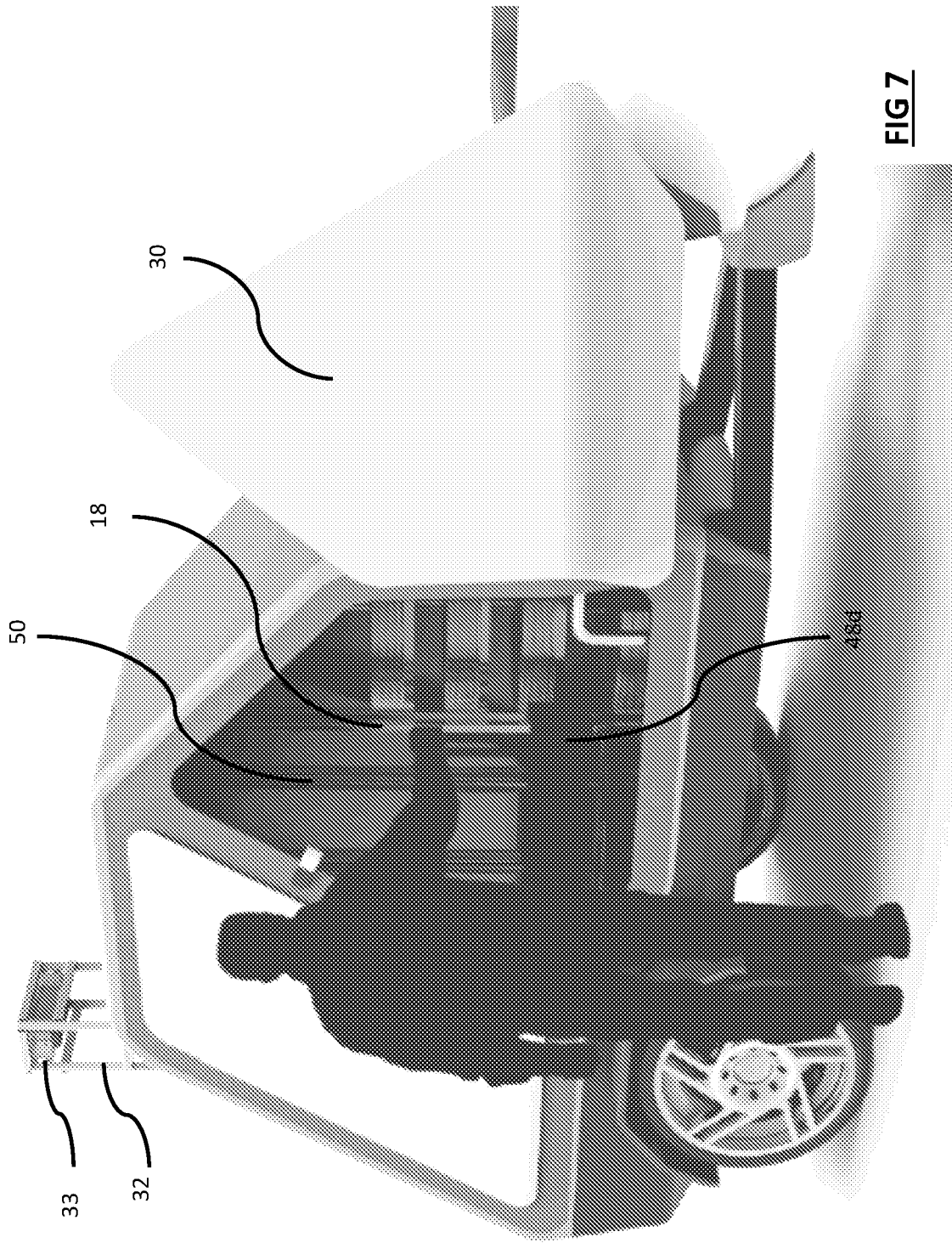

FIG 7

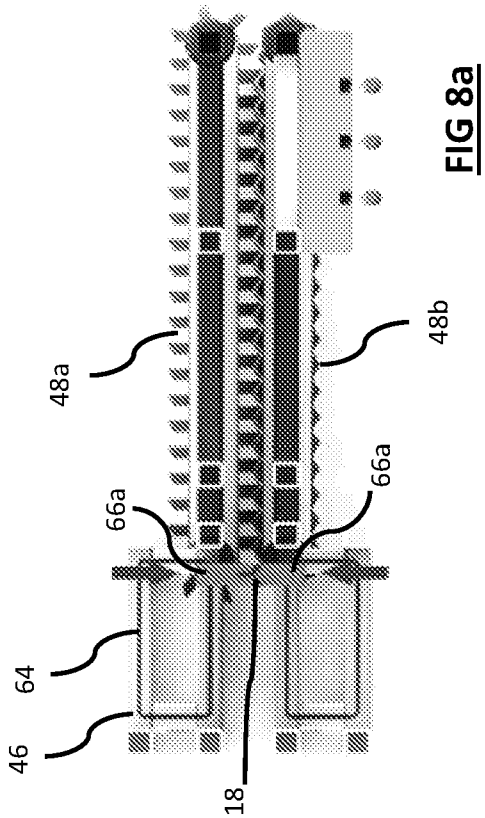

FIG 8a

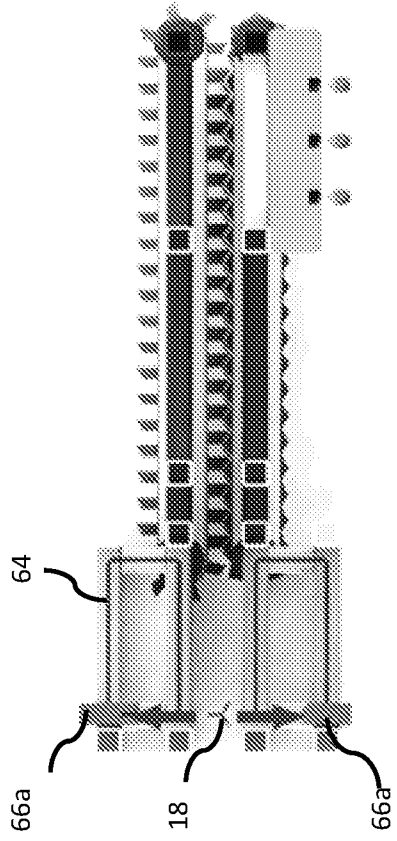

FIG 8c

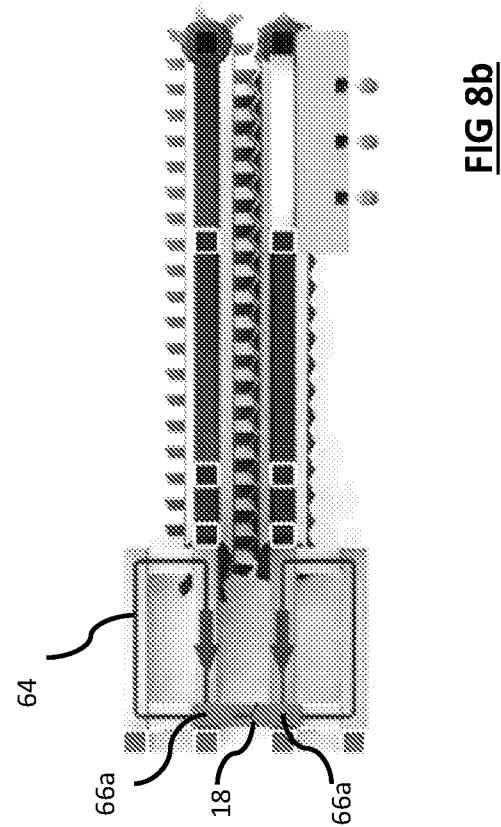

FIG 8b

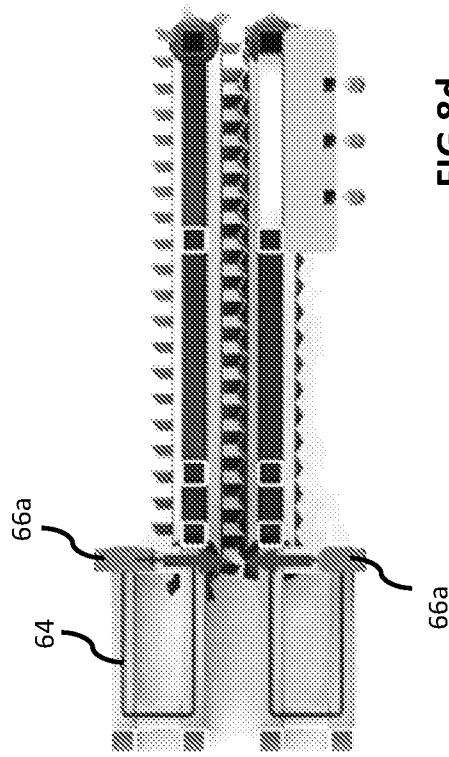

FIG 8d

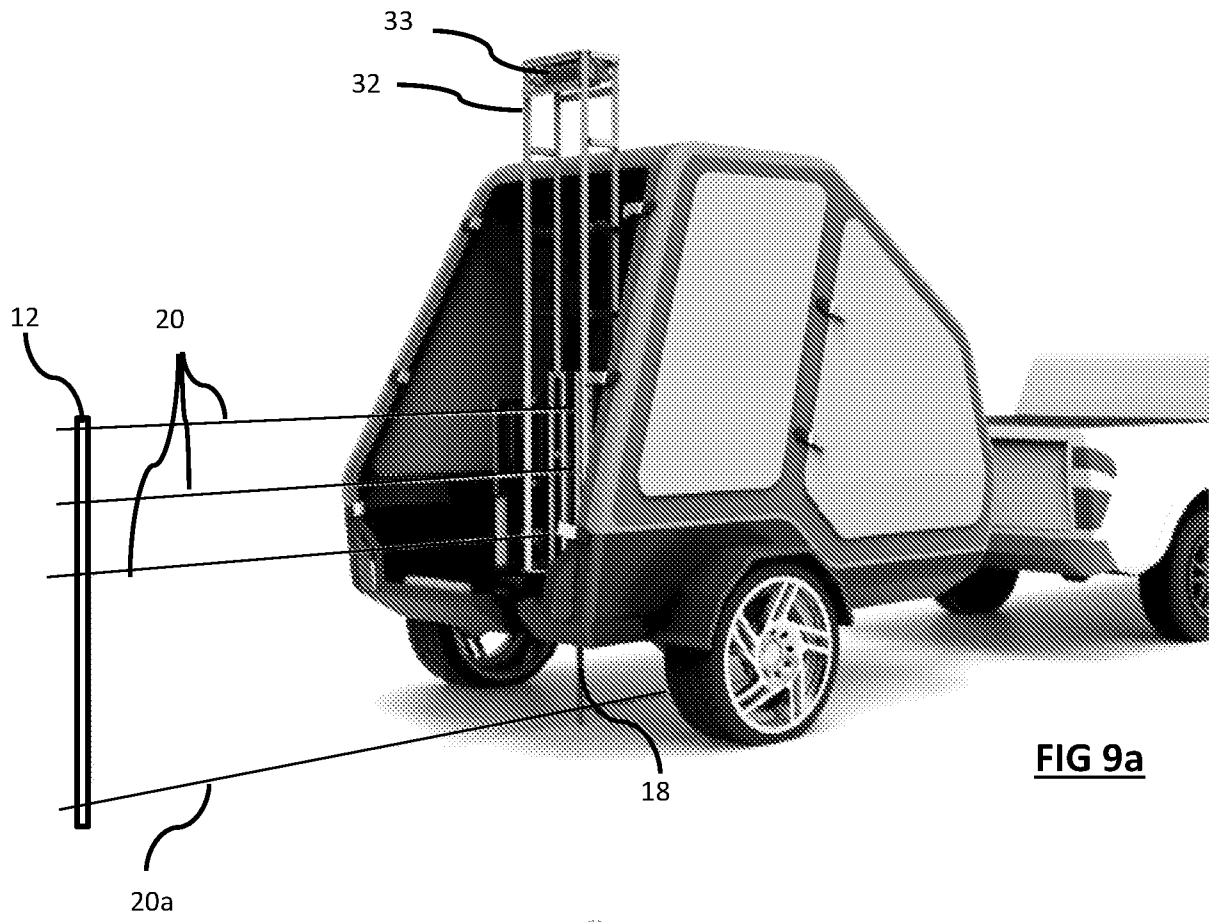

FIG 9a

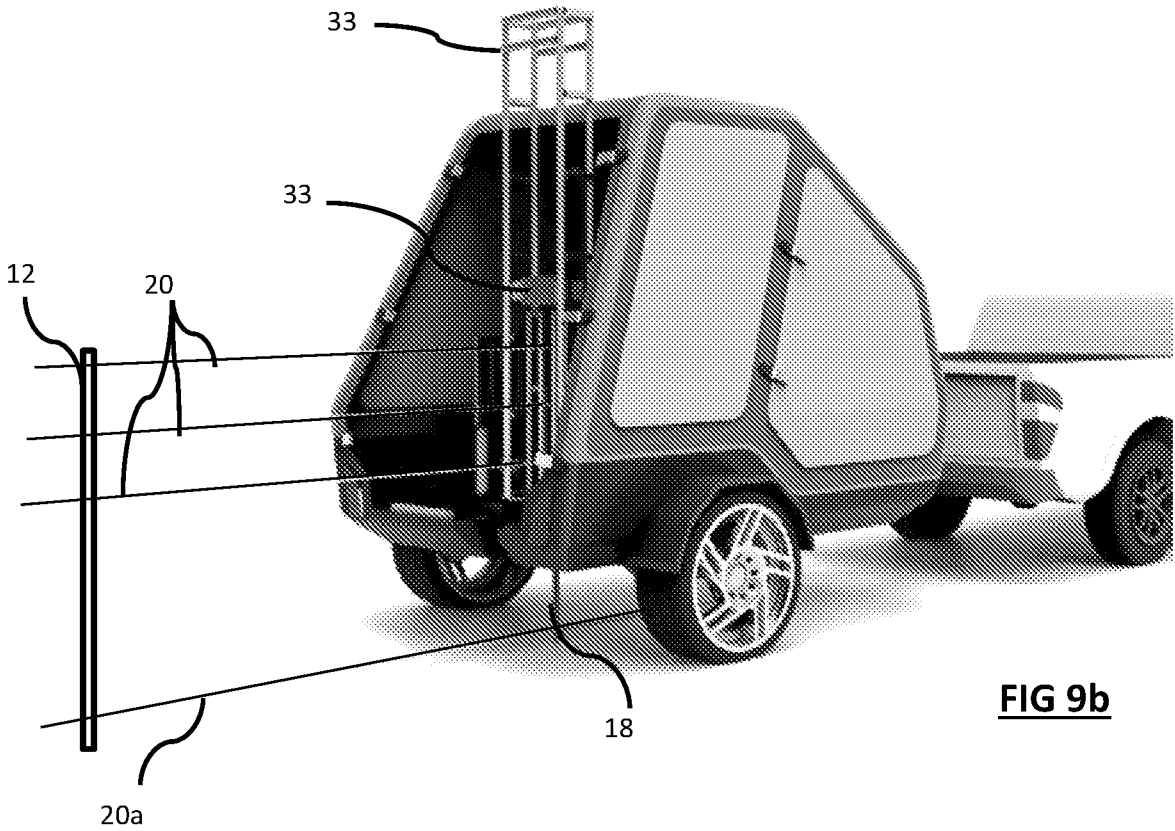

FIG 9b

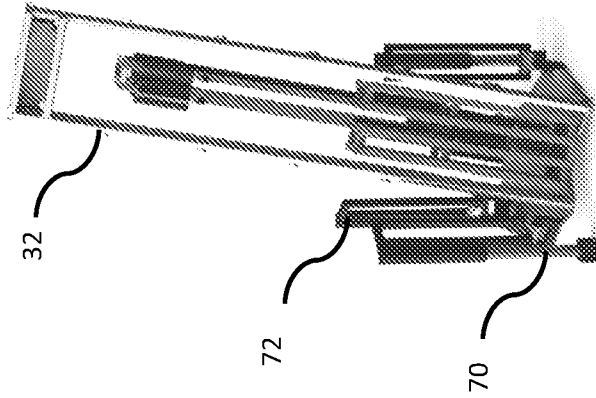

FIG 10c

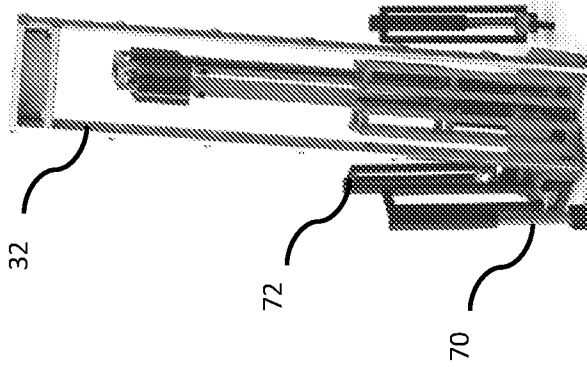

FIG 10b

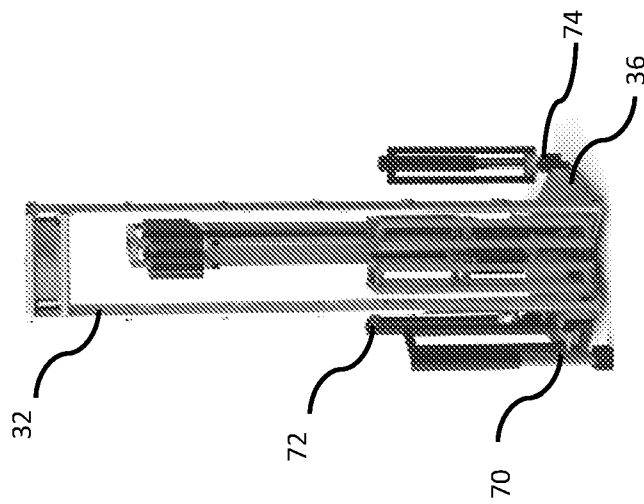

FIG 10a

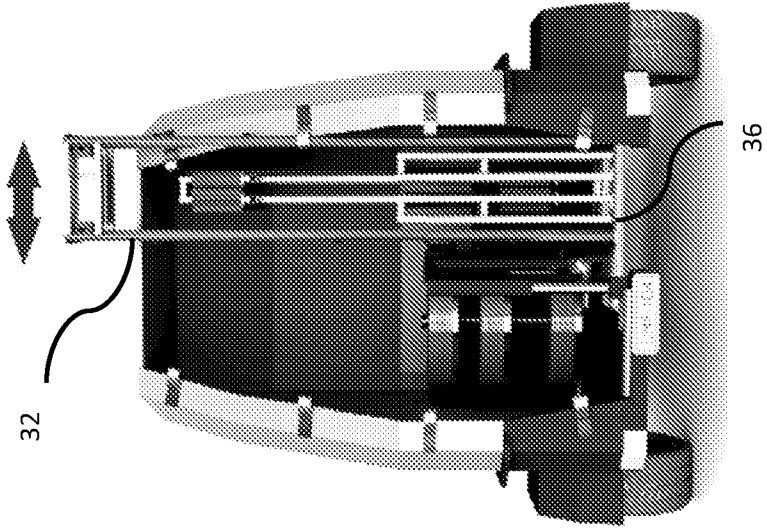

FIG 11a

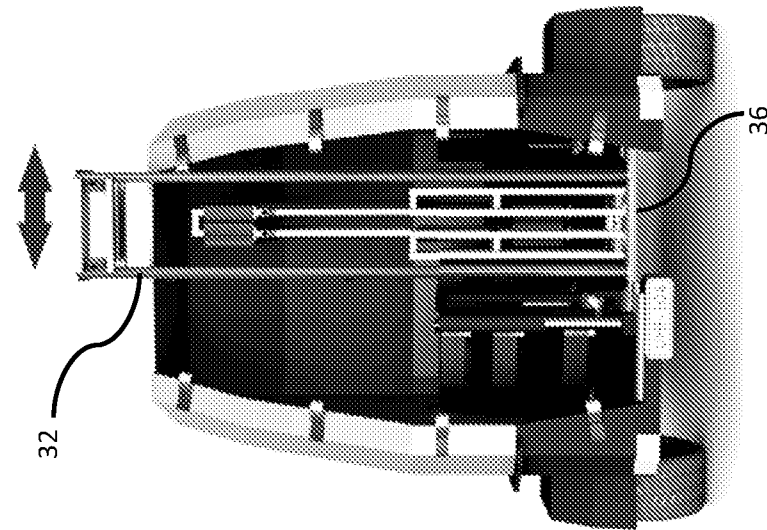

FIG 11b

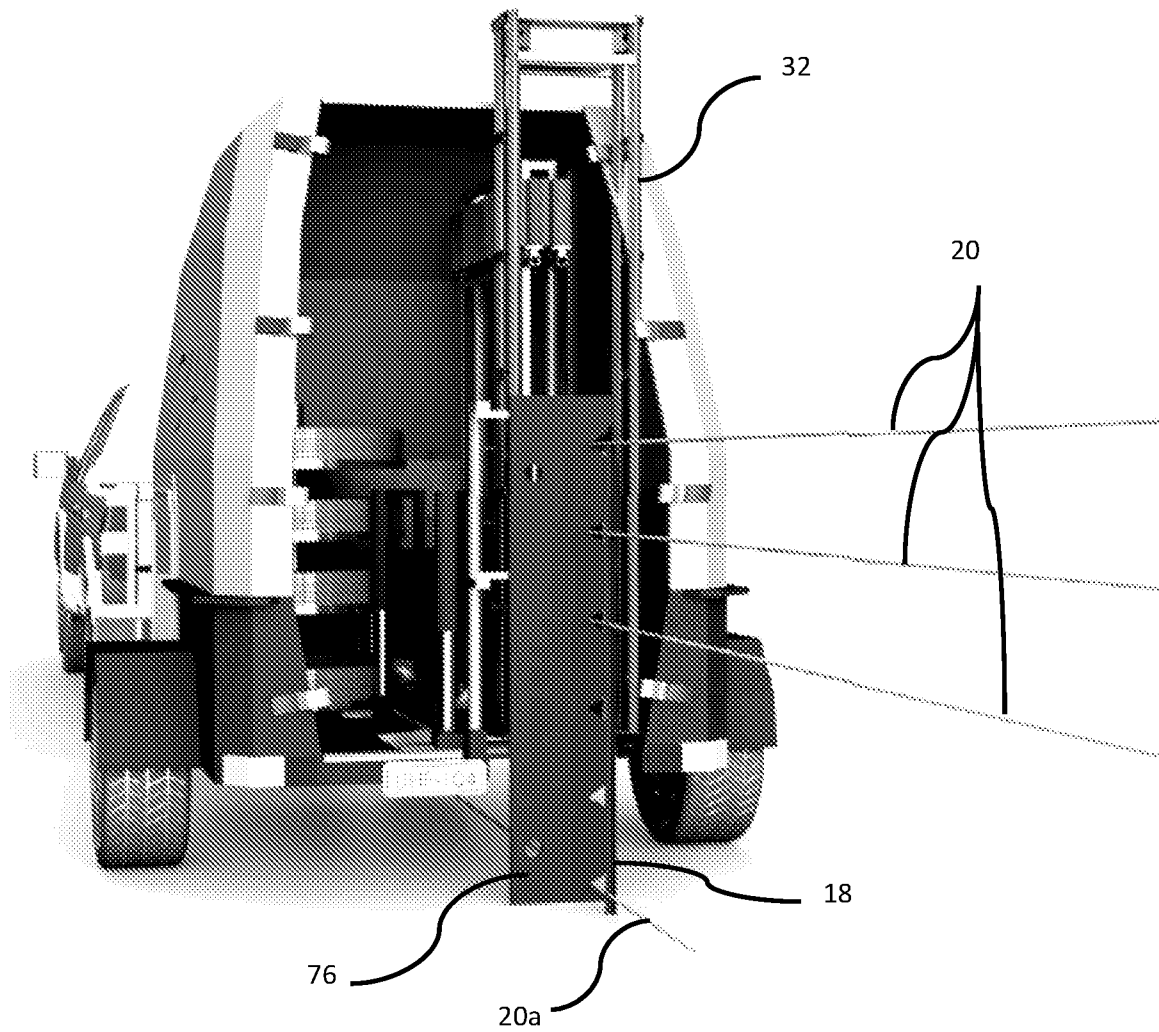

FIG 12

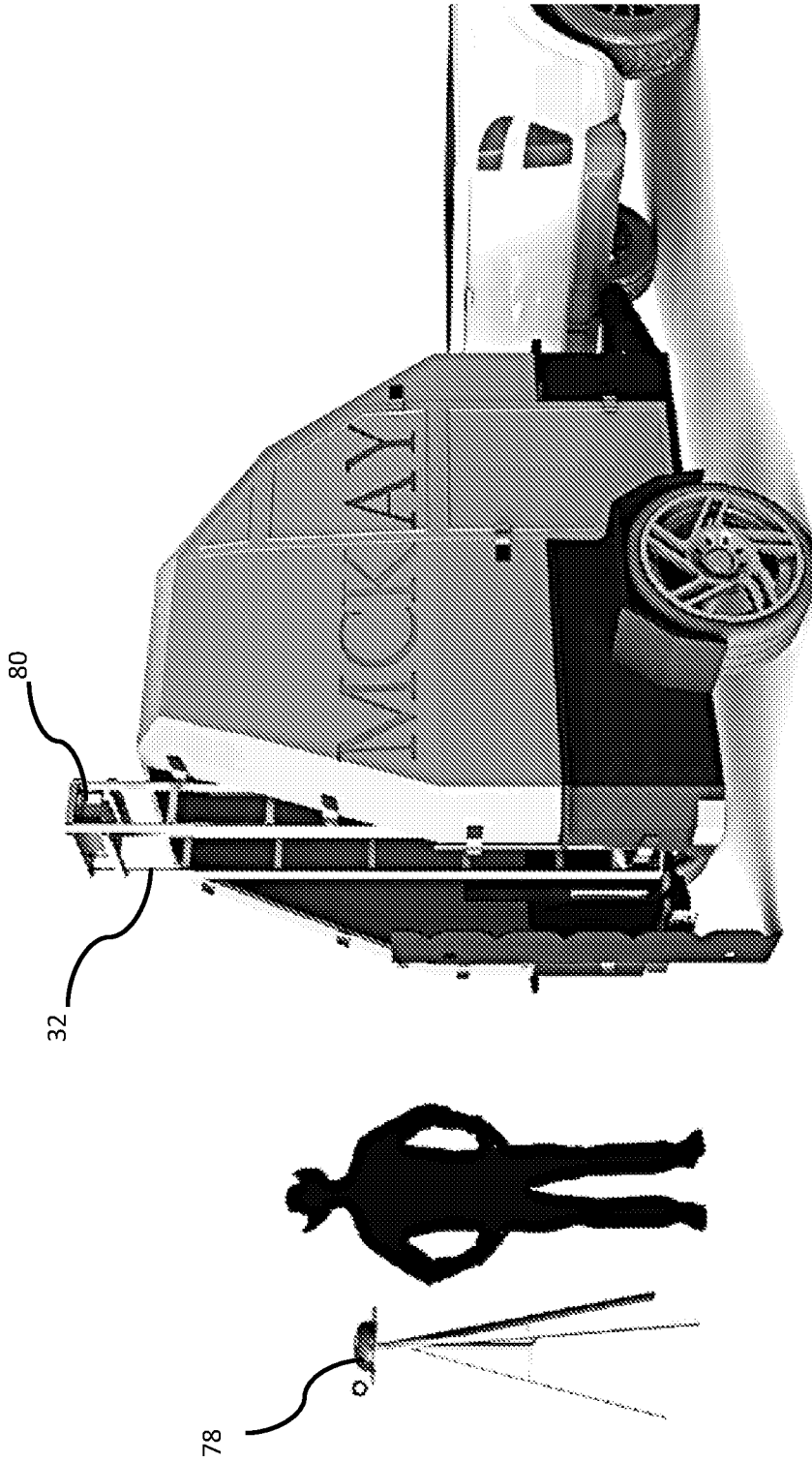

FIG 13

INTERNATIONAL SEARCH REPORT

International application No.

PCT/AU2018/051253

A. CLASSIFICATION OF SUBJECT MATTER

E04H 17/26 (2006.01) A01K 3/00 (2006.01)

According to International Patent Classification (IPC) or to both national classification and IPC

B. FIELDS SEARCHED

Minimum documentation searched (classification system followed by classification symbols)

Documentation searched other than minimum documentation to the extent that such documents are included in the fields searched

Electronic data base consulted during the international search (name of data base and, where practicable, search terms used)

DATABASES: PATENW, GOOGLE PATENTS, ESPACENET

IPC/CPC: E04H17, A01K3

KEYWORDS: (Vehicle, implement, driver, clamp, post, loop, move, GPS) and like terms in various combinations.

Applicant/Inventor searched in Espacenet, Auspat and IP Australia internal databases.

C. DOCUMENTS CONSIDERED TO BE RELEVANT

| Category* | Citation of document, with indication, where appropriate, of the relevant passages | Relevant to claim No. |
|-----------|------------------------------------------------------------------------------------|-----------------------|
| | Documents are listed in the continuation of Box C | |

 Further documents are listed in the continuation of Box C See patent family annex

| | | |
|-------------------------------------------------------------------------------------------------------------------------------------------------------------------------|-----|----------------------------------------------------------------------------------------------------------------------------------------------------------------------------------------------------------------------------------------------|
| * Special categories of cited documents: | | |
| "A" document defining the general state of the art which is not considered to be of particular relevance | "T" | later document published after the international filing date or priority date and not in conflict with the application but cited to understand the principle or theory underlying the invention |
| "E" earlier application or patent but published on or after the international filing date | "X" | document of particular relevance; the claimed invention cannot be considered novel or cannot be considered to involve an inventive step when the document is taken alone |
| "L" document which may throw doubts on priority claim(s) or which is cited to establish the publication date of another citation or other special reason (as specified) | "Y" | document of particular relevance; the claimed invention cannot be considered to involve an inventive step when the document is combined with one or more other such documents, such combination being obvious to a person skilled in the art |
| "O" document referring to an oral disclosure, use, exhibition or other means | "&" | document member of the same patent family |
| "P" document published prior to the international filing date but later than the priority date claimed | | |

Date of the actual completion of the international search
11 February 2019Date of mailing of the international search report
11 February 2019

Name and mailing address of the ISA/AU

AUSTRALIAN PATENT OFFICE
PO BOX 200, WODEN ACT 2606, AUSTRALIA
Email address: pct@ipaustralia.gov.au

Authorised officer

Parminder Singh
AUSTRALIAN PATENT OFFICE
(ISO 9001 Quality Certified Service)
Telephone No. +61262256135

INTERNATIONAL SEARCH REPORT

International application No.

C (Continuation).

DOCUMENTS CONSIDERED TO BE RELEVANT

PCT/AU2018/051253

| Category* | Citation of document, with indication, where appropriate, of the relevant passages | Relevant to claim No. |
|-----------|--------------------------------------------------------------------------------------------------------------------------|---------------------------|
| X A | US 2012/0112149 A1 (TATE) 10 May 2012 See abstract, figures 1-3 and paras [0007], [0045]-[0047] & [0090]-[0092] | 1-8 & 10-13 9, 14 & 15 |
| X A | US 3548604 A (CAMPBELL) 22 December 1970 See figure 6 & 8 | 14 & 15 1-13 |
| X A | EP 1887167 A2 (BRENNAN JOSEPH ANTHONY et al.) 13 February 2008 See abstract, figures 1, 2, 9, 17 & 18 and para [0052] | 14 & 15 1-13 |
| A | US 2017/0204633 A1 (CARL H. HUBENER) 20 July 2017 See figure 1 and para [0040] | 13 |

Box No. II Observations where certain claims were found unsearchable (Continuation of item 2 of first sheet)

This international search report has not been established in respect of certain claims under Article 17(2)(a) for the following reasons:

1. Claims Nos.:
because they relate to subject matter not required to be searched by this Authority, namely:
the subject matter listed in Rule 39 on which, under Article 17(2)(a)(i), an international search is not required to be carried out, including
2. Claims Nos.:
because they relate to parts of the international application that do not comply with the prescribed requirements to such an extent that no meaningful international search can be carried out, specifically:
3. Claims Nos.:
because they are dependent claims and are not drafted in accordance with the second and third sentences of Rule 6.4(a)

Box No. III Observations where unity of invention is lacking (Continuation of item 3 of first sheet)

This International Searching Authority found multiple inventions in this international application, as follows:

See Supplemental Box for Details

1. As all required additional search fees were timely paid by the applicant, this international search report covers all searchable claims.
2. As all searchable claims could be searched without effort justifying additional fees, this Authority did not invite payment of additional fees.
3. As only some of the required additional search fees were timely paid by the applicant, this international search report covers only those claims for which fees were paid, specifically claims Nos.:
4. No required additional search fees were timely paid by the applicant. Consequently, this international search report is restricted to the invention first mentioned in the claims; it is covered by claims Nos.:

Remark on Protest

- The additional search fees were accompanied by the applicant's protest and, where applicable, the payment of a protest fee.
- The additional search fees were accompanied by the applicant's protest but the applicable protest fee was not paid within the time limit specified in the invitation.
- No protest accompanied the payment of additional search fees.

Supplemental Box**Continuation of: Box III**

This International Application does not comply with the requirements of unity of invention because it does not relate to one invention or to a group of inventions so linked as to form a single general inventive concept.

This Authority has found that there are different inventions based on the following features that separate the claims into distinct groups:

1. Claims 1-13 are directed to a fencing system. The feature of the system is adapted to enable the platform to be moved forward and stopped at intermediate distances to drive posts into the ground, with wire being simultaneously fed adjacent the posts or through the posts is specific to this group of claims.
2. Claims 14 & 15 are directed to a self driving post driver system. The feature of a plurality of adjustable legs capable of independent adjustment in order to position the post held in the frame in a predetermined orientation relative to the ground; a processor and controller for independent adjustment of the legs is specific to this group of claims.

PCT Rule 13.2, first sentence, states that unity of invention is only fulfilled when there is a technical relationship among the claimed inventions involving one or more of the same or corresponding special technical features. PCT Rule 13.2, second sentence, defines a special technical feature as a feature which makes a contribution over the prior art.

When there is no special technical feature common to all the claimed inventions there is no unity of invention.

In the above groups of claims, the identified features may have the potential to make a contribution over the prior art but are not common to all the claimed inventions and therefore cannot provide the required technical relationship. The only feature common to all of the claimed inventions is a post driver system. However it is considered that this feature is generic in this particular art. See D1: US 2012/0112149 A1 (TATE) 10 May 2012.

Therefore this common feature cannot be a special technical feature. Hence there is no special technical feature common to all the claimed inventions and the requirements for unity of invention are consequently not satisfied *a posteriori*.

INTERNATIONAL SEARCH REPORT

Information on patent family members

International application No.

PCT/AU2018/051253

This Annex lists known patent family members relating to the patent documents cited in the above-mentioned international search report. The Australian Patent Office is in no way liable for these particulars which are merely given for the purpose of information.

| Patent Document/s Cited in Search Report | | Patent Family Member/s | |
|-------------------------------------------------|-------------------------|-------------------------------|-------------------------|
| Publication Number | Publication Date | Publication Number | Publication Date |
| US 2012/0112149 A1 | 10 May 2012 | US 2012112149 A1 | 10 May 2012 |
| | | US 9022136 B2 | 05 May 2015 |
| | | AU 2010215071 A1 | 08 Sep 2011 |
| | | AU 2010215071 B2 | 17 Oct 2013 |
| | | CA 2752712 A1 | 26 Aug 2010 |
| | | NZ 594631 A | 27 Sep 2013 |
| | | WO 2010094070 A1 | 26 Aug 2010 |
| US 3548604 A | 22 December 1970 | US 3548604 A | 22 Dec 1970 |
| EP 1887167 A2 | 13 February 2008 | EP 1887167 A2 | 13 Feb 2008 |
| | | IE 20070574 A1 | 11 Jun 2008 |
| | | IE S20070575 A2 | 20 Aug 2008 |
| US 2017/0204633 A1 | 20 July 2017 | US 2017204633 A1 | 20 Jul 2017 |

End of Annex