



- (51) International Patent Classification:
G01V 1/30 (2006.01) G06F 17/50 (2006.01)
- (21) International Application Number:
PCT/RU2017/000264
- (22) International Filing Date:
25 April 2017 (25.04.2017)
- (25) Filing Language: English
- (26) Publication Language: English
- (30) Priority Data:
62/329,117 28 April 2016 (28.04.2016) US
- (71) Applicant (for CA only): SCHLUMBERGER CANADA LIMITED [CA/CA]; 125-9 Avenue SE, Alberta, Calgary, T2G 0P6 (CA).
- (71) Applicant (for FR only): SERVICES PETROLIERS SCHLUMBERGER [FR/FR]; 42 rue Saint Dominique, 75007 Paris (FR).
- (71) Applicant (for all designated States except CA, FR, US): SCHLUMBERGER TECHNOLOGY B.V. [NL/NL]; Parkstraat 83-89m, NL-2514 JG The Hague (NL).
- (71) Applicant (for US only): SCHLUMBERGER TECHNOLOGY CORPORATION [US/US]; 300 Schlumberger Drive, Sugar Land, Texas, 77478 (US).
- (72) Inventor; and
(71) Applicant (for US only): SOFRONOV, Ivan L'vovich [RU/RU]; Khabarovskaya str. 11/28-53, Moscow, 107589 (RU).
- (72) Inventors: KOROTEEV, Dmitry Anatolievich; Vasilisy Kozhinoy str.14-1-49, Moscow, 191026 (RU). BULOVA, Marina Nikolaevna; Krupskoy str.,5-77, Moscow, 119331 (RU). BELANI, Ashok K; 300 Schlumberger Drive, Sugar Land, Texas, 77478 (US).
- (74) Agent: ARKHIPOVA, Vera Nikolaevna; Technology Company Schlumberger, Pudovkina str., 13, Moscow, 119285 (RU).
- (81) Designated States (unless otherwise indicated, for every kind of national protection available): AE, AG, AL, AM, AO, AT, AU, AZ, BA, BB, BG, BH, BN, BR, BW, BY, BZ, CA, CH, CL, CN, CO, CR, CU, CZ, DE, DJ, DK, DM, DO, DZ, EC, EE, EG, ES, FI, GB, GD, GE, GH, GM, GT, HN, HR, HU, ID, IL, IN, IR, IS, JP, KE, KG, KH, KN, KP, KR, KW, KZ, LA, LC, LK, LR, LS, LU, LY, MA, MD, ME, MG, MK, MN, MW, MX, MY, MZ, NA, NG, NI, NO, NZ, OM, PA, PE, PG, PH, PL, PT, QA, RO, RS, RU, RW, SA, SC,

(54) Title: RESERVOIR PERFORMANCE SYSTEM

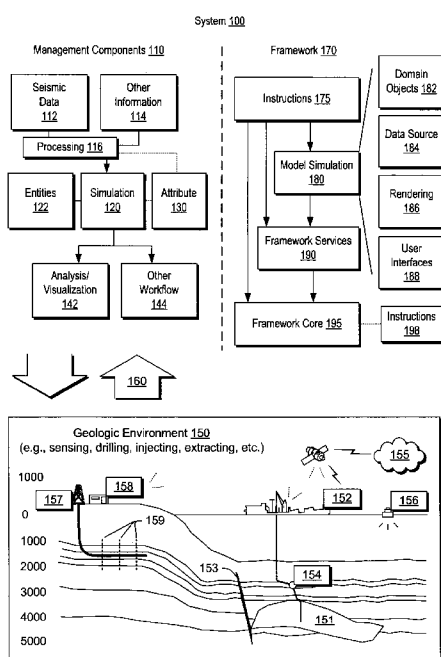

Fig. 1

(57) Abstract: A system includes an input component that includes a network interface that receives data where the data includes data acquired by one or more pieces of field equipment during an operation at a field site and a reservoir model; a database component that includes a database and a data analyzer operative coupled to the network interface; a machine learning component operatively coupled to the database component and to a reservoir simulation framework that utilizes the reservoir model where the machine learning component includes a machine learning mode that generates at least one trained machine learning algorithm and an operational mode that generates results based at least in part on at least one trained machine learning algorithm; and an output component operatively coupled to the database component where the output component outputs information based at least in part on the results of the operational mode of the machine learning component.



WO 2017/188858 A1

SD, SE, SG, SK, SL, SM, ST, SV, SY, TH, TJ, TM, TN, TR,
TT, TZ, UA, UG, US, UZ, VC, VN, ZA, ZM, ZW.

(84) Designated States (*unless otherwise indicated, for every kind of regional protection available*): ARIPO (BW, GH, GM, KE, LR, LS, MW, MZ, NA, RW, SD, SL, ST, SZ, TZ, UG, ZM, ZW), Eurasian (AM, AZ, BY, KG, KZ, RU, TJ, TM), European (AL, AT, BE, BG, CH, CY, CZ, DE, DK, EE, ES, FI, FR, GB, GR, HR, HU, IE, IS, IT, LT, LU, LV, MC, MK, MT, NL, NO, PL, PT, RO, RS, SE, SI, SK, SM, TR), OAPI (BF, BJ, CF, CG, CI, CM, GA, GN, GQ, GW, KM, ML, MR, NE, SN, TD, TG).

Published:

- *with international search report (Art. 21(3))*
- *before the expiration of the time limit for amending the claims and to be republished in the event of receipt of amendments (Rule 48.2(h))*

RESERVOIR PERFORMANCE SYSTEM

BACKGROUND

[0001] A reservoir can be a subsurface formation that can be characterized at least in part by its porosity and fluid permeability. As an example, a reservoir may be part of a basin such as a sedimentary basin. A basin can be a depression (e.g., caused by plate tectonic activity, subsidence, etc.) in which sediments accumulate. As an example, where hydrocarbon source rocks occur in combination with appropriate depth and duration of burial, a petroleum system may develop within a basin, which may form a reservoir that includes hydrocarbon fluids (e.g., oil, gas, etc.).

SUMMARY

[0002] A system includes an input component that includes at least one network interface that receives data where the data includes data acquired by one or more pieces of field equipment during an operation at a field site and a reservoir model; a database component that includes a database and a data analyzer operative coupled to the network interface for receipt of the data; a machine learning component operatively coupled to the database component and operatively coupled to a reservoir simulation framework that utilizes the reservoir model where the machine learning component includes a machine learning mode that generates at least one trained machine learning algorithm and an operational mode that generates results based at least in part on at least one trained machine learning algorithm; and an output component operatively coupled to the database component where the output component outputs information based at least in part on the results of the operational mode of the machine learning component. A method includes receiving, via a network interface, data acquired by one or more pieces of field equipment during an operation at a field site; accessing a database

to retrieve information associated with the field site; based at least in part on the data and the information, generating a trained machine learning algorithm; executing, based at least in part on the data and the information, the trained machine learning algorithm using one or more processors to generate a result; and based at least in part on the result, predicting an outcome for the operation at the field site and transmitting the outcome to the database. One or more computer-readable storage media include computer-executable instructions where the computer-executable instructions include instructions to instruct a computing system to: receive, via a network interface, data acquired by one or more pieces of field equipment during an operation at a field site; access a database to retrieve information associated with the field site; based at least in part on the data and the information, generate a trained machine learning algorithm; execute, based at least in part on the data and the information, the trained machine learning algorithm using one or more processors to generate a result; and based at least in part on the result, predict an outcome for the operation at the field site and transmitting the outcome to the database. Various other apparatuses, systems, methods, etc., are also disclosed.

[0003] This summary is provided to introduce a selection of concepts that are further described below in the detailed description. This summary is not intended to identify key or essential features of the claimed subject matter, nor is it intended to be used as an aid in limiting the scope of the claimed subject matter.

BRIEF DESCRIPTION OF THE DRAWINGS

[0004] Features and advantages of the described implementations can be more readily understood by reference to the following description taken in conjunction with the accompanying drawings.

[0005] Fig. 1 illustrates an example system that includes various components for simulating a geological environment;

[0006] Fig. 2 illustrates examples of a basin, a convention and a system;

- [0007] Fig. 3 illustrates an example of a method;
- [0008] Fig. 4 illustrates an example of a system and an example of a method;
- [0009] Fig. 5 illustrates an example of an architecture;
- [0010] Fig. 6 illustrates an example of a system;
- [0011] Fig. 7 illustrates an example of a system;
- [0012] Fig. 8 illustrates an example of a system;
- [0013] Fig. 9 illustrates an example of a system;
- [0014] Fig. 10 illustrates an example of a system;
- [0015] Fig. 11 illustrates an example of a system;
- [0016] Fig. 12 illustrates an example of a system;
- [0017] Fig. 13 illustrates an example of a geologic environment and examples of equipment;
- [0018] Fig. 14 illustrates examples of geologic environments and examples of equipment;
- [0019] Fig. 15 illustrates an example of a diagram as to phases and states of a system and an example of a field site;
- [0020] Fig. 16 illustrates examples of computer and network equipment; and
- [0021] Fig. 17 illustrates example components of a system and a networked system.

DETAILED DESCRIPTION

[0022] This description is not to be taken in a limiting sense, but rather is made merely for the purpose of describing the general principles of the implementations. The scope of the described implementations should be ascertained with reference to the issued claims.

[0023] Fig. 1 shows an example of a system 100 that includes various management components 110 to manage various aspects of a geologic

environment 150 (e.g., an environment that includes a sedimentary basin, a reservoir 151, one or more faults 153, one or more fractures 159, etc.). For example, the management components 110 may allow for direct or indirect management of sensing, drilling, injecting, extracting, etc., with respect to the geologic environment 150. In turn, further information about the geologic environment 150 may become available as feedback 160 (e.g., optionally as input to one or more of the management components 110).

[0024] In the example of Fig. 1, the management components 110 include a seismic data component 112, an additional information component 114 (e.g., well/logging data, etc.), a processing component 116, a simulation component 120, an attribute component 130, an analysis/visualization component 142 and a workflow component 144. In operation, as an example, seismic data and other information provided per the components 112 and 114 may be input to the simulation component 120.

[0025] In the example of Fig. 1, the seismic data component 112 may provide seismic data as acquired via reflection seismology, which finds use in geophysics, for example, to estimate properties of subsurface formations. As an example, reflection seismology may provide seismic data representing waves of elastic energy (e.g., as transmitted by P-waves and S-waves, in a frequency range of approximately 1 Hz to approximately 100 Hz). Seismic data may be processed and interpreted, for example, to understand better composition, fluid content, extent and geometry of subsurface rocks. Such interpretation results can be utilized to plan, perform, etc., one or more operations for production of fluid from a reservoir (e.g., reservoir rock, etc.).

[0026] Field acquisition equipment may be utilized to acquire seismic data, which may be in the form of traces where a trace can include values organized with respect to time and/or depth (e.g., consider 1D, 2D, 3D or 4D seismic data). For example, consider acquisition equipment that acquires digital samples at a rate of one sample per approximately 4 ms. Given a speed of sound in a medium

or media, a sample rate may be converted to an approximate distance. For example, the speed of sound in rock may be on the order of around 5 km per second. Thus, a sample time spacing of approximately 4 ms would correspond to a sample “depth” spacing of about 10 meters (e.g., assuming a path length from source to boundary and boundary to sensor). As an example, a trace may be about 4 seconds in duration; thus, for a sampling rate of one sample at about 4 ms intervals, such a trace would include about 1000 samples where latter acquired samples correspond to deeper reflection boundaries. If the 4 second trace duration of the foregoing example is divided by two (e.g., to account for reflection), for a vertically aligned source and sensor, a deepest boundary depth may be estimated to be about 10 km (e.g., assuming a speed of sound of about 5 km per second).

[0027] As an example, the simulation component 120 may include features that allow for building a model or models of a geologic environment. As an example, a model may be a simulated version of a geologic environment. As an example, a simulator may include features for simulating physical phenomena in a geologic environment based at least in part on a model or models. As an example, one or more of the management components 110 may be part of a seismic-to-simulation framework and may include or may be operatively coupled to, for example, one or more components that can simulate physical phenomena in a geologic environment. For example, a simulator, such as a reservoir simulator, can simulate fluid flow in a geologic environment based at least in part on a model that can be generated via a framework that receives seismic data. A simulator can be a computerized system (e.g., a computing system) that can execute instructions using one or more processors to solve a system of equations that describe physical phenomena subject to various constraints. The system of equations may be spatial defined (e.g., numerically discretized) according to a spatial model that that includes layers of rock, geobodies, etc., that have corresponding positions that can be based on interpretation of seismic and/or

other data. A spatial model may be a cell-based model where cells are defined by a grid (e.g., a mesh). A cell in a cell-based model can represent a physical area or volume in a geologic environment where the cell can be assigned physical properties (e.g., permeability, fluid properties, etc.) that may be germane to one or more physical phenomena (e.g., fluid volume, fluid flow, pressure, etc.). A reservoir simulation model can be a spatial model that may be cell-based.

[0028] A simulator can be utilized to simulate the exploitation of a real reservoir, for example, to examine different productions scenarios to find an optimal one before production or further production occurs. A reservoir simulator does not provide an exact replica of flow in and production from a reservoir at least in part because the description of the reservoir and the boundary conditions for the equations for flow in a porous rock are generally known with an amount of uncertainty. Certain types of physical phenomena occur at a spatial scale that can be relatively small compared to size of a field. A balance can be struck between model scale and computational resources that results in model cell sizes being of the order of meters; rather than a lesser size (e.g., a level of detail of pores). A modeling and simulation workflow for multiphase flow in porous media (e.g., reservoir rock, etc.) can include generalizing real micro-scale data from macro scale observations (e.g., seismic data and well data) and upscaling to a manageable scale and problem size. Uncertainties can exist in input data and solution procedure such that simulation results too are to some extent uncertain. A process known as history matching can involve comparing simulation results to actual field data acquired during production of fluid from a field. Information gleaned from history matching, can provide for adjustments to a model, data, etc., which can help to increase accuracy of simulation.

[0029] In an example embodiment, the simulation component 120 may include accessing entities 122. Entities 122 may include earth entities or geological objects such as wells, surfaces, reservoirs, etc. In the system 100, the entities 122 can include virtual representations of actual physical entities that may

be reconstructed for purposes of simulation. The entities 122 may include entities based on data acquired via sensing, observation, etc. (e.g., consider entities based at least in part on the seismic data 112 and/or other information 114). As an example, an entity may be characterized by one or more properties (e.g., a geometrical pillar grid entity of an earth model may be characterized by a porosity property, etc.). Such properties may represent one or more measurements (e.g., acquired data), calculations, etc.

[0030] In an example embodiment, the simulation component 120 may operate in conjunction with a software framework such as an object-based framework. In such a framework, entities may include entities based on pre-defined classes to facilitate modeling and simulation. A commercially available example of an object-based framework is the MICROSOFT™ .NET™ framework (Redmond, Washington), which provides a set of extensible object classes. In the .NET™ framework, an object class encapsulates a module of reusable code and associated data structures. Object classes can be used to instantiate object instances for use by a program, script, etc. For example, borehole classes may define objects for representing boreholes based on well data. A model of a basin, a reservoir, etc. may include one or more boreholes where a borehole may be, for example, for measurements, injection, production, etc. As an example, a borehole may be a wellbore of a well, which may be a completed well (e.g., for production of a resource from a reservoir, for injection of material, etc.).

[0031] In the example of Fig. 1, the simulation component 120 may process information to conform to one or more attributes specified by the attribute component 130, which may include a library of attributes (e.g., consider a library that includes seismic attributes, etc.). Such processing may occur prior to input to the simulation component 120 (e.g., consider the processing component 116). As an example, the simulation component 120 may perform operations on input information based on one or more attributes specified by the attribute component

130. In an example embodiment, the simulation component 120 may construct one or more models of the geologic environment 150, which may be utilized to simulate behavior of the geologic environment 150 (e.g., responsive to one or more acts, whether natural or artificial). In the example of Fig. 1, the analysis/visualization component 142 may allow for interaction with a model or model-based results (e.g., simulation results, etc.). As an example, output from the simulation component 120 may be input to one or more other workflows, as indicated by a workflow component 144.

[0032] As an example, the simulation component 120 may include one or more features of a simulator such as, for example, the ECLIPSE® reservoir simulator (Schlumberger Limited, Houston Texas), the INTERSECT® reservoir simulator (Schlumberger Limited, Houston Texas), the VISAGE® geomechanics simulator (Schlumberger Limited, Houston Texas), the PETROMOD® petroleum systems simulator (Schlumberger Limited, Houston Texas), the PIPESIM® network simulator (Schlumberger Limited, Houston Texas), etc.

[0033] The ECLIPSE® simulator includes numerical solvers that may provide simulation results such as, for example, results that may predict dynamic behavior for one or more types of reservoirs, may assist with one or more development schemes, may assist with one or more production schemes, etc. The VISAGE® simulator includes finite element numerical solvers that may provide simulation results such as, for example, results as to compaction and subsidence of a geologic environment, well and completion integrity in a geologic environment, cap-rock and fault-seal integrity in a geologic environment, fracture behavior in a geologic environment, thermal recovery in a geologic environment, CO₂ disposal, etc. The PETROMOD® simulator includes finite element numerical solvers that may provide simulations results such as, for example, results as to structural evolution, temperature, and pressure history and as to effects of such factors on generation, migration, accumulation, and loss of oil and gas in a petroleum system through geologic time. Such a simulator can provide

properties such as, for example, gas/oil ratios (GOR) and API gravities, which may be analyzed, understood, and predicted as to a geologic environment. The PIPESIM™ simulator includes solvers that may provide simulation results such as, for example, multiphase flow results (e.g., from a reservoir to a wellhead and beyond, etc.), flowline and surface facility performance, etc. The PIPESIM® simulator may be integrated, for example, with the AVOCET® production operations framework (Schlumberger Limited, Houston Texas). As an example, a reservoir or reservoirs may be simulated with respect to one or more enhanced recovery techniques (e.g., consider a thermal process such as steam-assisted gravity drainage (SAGD), etc.). As an example, the PIPESIM® simulator may be an optimizer that can optimize one or more operational scenarios at least in part via simulation of physical phenomena.

[0034] In an example embodiment, the management components 110 may include features of a commercially available framework such as the PETREL® seismic to simulation software framework (Schlumberger Limited, Houston, Texas). The PETREL® framework provides components that allow for optimization of exploration and development operations. The PETREL® framework includes seismic to simulation software components that can output information for use in increasing reservoir performance, for example, by improving asset team productivity. Through use of such a framework, various professionals (e.g., geophysicists, geologists, and reservoir engineers) can develop collaborative workflows and integrate operations to streamline processes (e.g., with respect to one or more geologic environments, etc.). Such a framework may be considered an application (e.g., executable using one or more devices) and may be considered a data-driven application (e.g., where data is input for purposes of modeling, simulating, etc.).

[0035] In an example embodiment, various aspects of the management components 110 may include add-ons or plug-ins that operate according to specifications of a framework environment. For example, a commercially

available framework environment marketed as the OCEAN® framework environment (Schlumberger Limited, Houston, Texas) allows for integration of add-ons (or plug-ins) into a PETREL® framework workflow. The OCEAN® framework environment leverages .NET™ tools (Microsoft Corporation, Redmond, Washington) and offers stable, user-friendly interfaces for efficient development. In an example embodiment, various components may be implemented as add-ons (or plug-ins) that conform to and operate according to specifications of a framework environment (e.g., according to application programming interface (API) specifications, etc.).

[0036] Fig. 1 also shows an example of a framework 170 that includes a model simulation layer 180 along with a framework services layer 190, a framework core layer 195 and an instructions layer 175. As an example, the instructions layer 175 can include various sets of instructions that may be stored in a computer-readable storage medium or media where the instructions can be executable by one or more processors to instruct a computing device, a computing system, etc. to perform one or more operations. As an example, a component may be or include a set of instructions or sets of instructions. In the example of Fig. 1, the framework 170 may include the commercially available OCEAN® framework where the model simulation layer 180 is the commercially available PETREL® model-centric software package that hosts OCEAN® framework applications. In an example embodiment, the PETREL® software may be considered a data-driven application. The PETREL® software can include a framework for model building and visualization. Such a model may include one or more grids.

[0037] The model simulation layer 180 may provide domain objects 182, act as a data source 184, provide for rendering 186 and provide for various user interfaces 188. Rendering 186 may provide a graphical environment in which applications can display their data while the user interfaces 188 may provide a common look and feel for application user interface components. As an example,

a user interface may be a graphical user interface (GUI) that can be rendered to a display, via a virtual reality (VR) system, etc. As an example, a VR system may include one or more features of a VR system such as, for example, the HOLOLENS® VR system marketed by Microsoft Corporation (Redmond, Washington). For example, a VR system may include goggles and/or one or more other types of wearables that can facilitate generation of and/or interaction with a virtual environment.

[0038] In the example of Fig. 1, the domain objects 182 can include entity objects, property objects and optionally other objects. Entity objects may be used to geometrically represent wells, surfaces, reservoirs, etc., while property objects may be used to provide property values as well as data versions and display parameters. For example, an entity object may represent a well where a property object provides log information as well as version information and display information (e.g., to display the well as part of a model).

[0039] In the example of Fig. 1, data may be stored in one or more data sources (or data stores, generally physical data storage devices), which may be at the same or different physical sites and accessible via one or more networks. As an example, the model simulation layer 180 may be configured to model projects. As such, a particular project may be stored where stored project information may include inputs, models, results and cases. As an example, upon completion of a modeling session, a user may store a project. In such an example, at a later time, the project may be accessed and restored using the model simulation layer 180, which can recreate instances of the relevant domain objects.

[0040] In the example of Fig. 1, the geologic environment 150 may include layers (e.g., stratification) that include a reservoir 151 and that may be intersected by a fault 153. As an example, the geologic environment 150 may be outfitted with any of a variety of sensors, detectors, actuators, etc. For example, equipment 152 may include communication circuitry to receive and to transmit information with respect to one or more networks 155. Such information may include

information associated with downhole equipment 154, which may be equipment to acquire information, to assist with resource recovery, etc. Other equipment 156 may be located remote from a well site and include sensing, detecting, emitting or other circuitry. Such equipment may include storage and communication circuitry to store and to communicate data, instructions, etc. As an example, one or more satellites may be provided for purposes of communications, data acquisition, etc. For example, Fig. 1 shows a satellite in communication with the network 155 that may be configured for communications, noting that the satellite may additionally or alternatively include circuitry for imagery (e.g., spatial, spectral, temporal, radiometric, etc.).

[0041] Fig. 1 also shows the geologic environment 150 as optionally including equipment 157 and 158 associated with a well that includes a substantially horizontal portion that may intersect with the one or more fractures 159. For example, consider a well in a shale formation that may include natural fractures, artificial fractures (e.g., hydraulic fractures) or a combination of natural and artificial fractures. As an example, a well may be drilled for a reservoir that is laterally extensive. In such an example, lateral variations in properties, stresses, etc. may exist where an assessment of such variations may assist with planning, operations, etc. to develop a laterally extensive reservoir (e.g., via fracturing, injecting, extracting, etc.). As an example, the equipment 157 and/or 158 may include components, a system, systems, etc. for fracturing, seismic sensing, analysis of seismic data, assessment of one or more fractures, etc.

[0042] As mentioned, the system 100 may be used to perform one or more workflows. A workflow may be a process that includes a number of worksteps. A workstep may operate on data, for example, to create new data, to update existing data, etc. As an example, a may operate on one or more inputs and create one or more results, for example, based on one or more algorithms. As an example, a system may include a workflow editor for creation, editing, executing, etc. of a workflow. In such an example, the workflow editor may provide for

selection of one or more pre-defined worksteps, one or more customized worksteps, etc. As an example, a workflow may be a workflow implementable in the PETREL® framework, for example, that operates on seismic data, seismic attribute(s), etc. As an example, a workflow may be a process implementable in the OCEAN® framework. As an example, a workflow may include one or more worksteps that access instructions such as instructions of a plug-in (e.g., external executable code, etc.).

[0043] Fig. 1 also shows instructions 198, which may operate in conjunction with the framework 170. For example, the instructions 198 may be implemented as one or more plug-ins, one or more external sets of instructions, one or more components, etc. As an example, the instructions 198 may include sets of instructions associated with the commercially available TECHLOG® framework (Schlumberger Limited, Houston, TX), which can provide wellbore-centric, cross-domain workflows based on a data management layer. The TECHLOG® framework includes features for petrophysics (core and log), geology, drilling, reservoir and production engineering, and geophysics. As an example, data received via the TECHLOG® framework may be utilized by one or more inversion algorithms, which may aim to generate spatially distributed properties of a subterranean environment.

[0044] Fig. 2 shows an example of a sedimentary basin 210 (e.g., a geologic environment), an example of a method 220 for model building (e.g., for a simulator, etc.), an example of a formation 230, an example of a borehole 235 in a formation, an example of a convention 240 and an example of a system 250.

[0045] As an example, data acquisition, reservoir simulation, petroleum systems modeling, etc. may be applied to characterize various types of subsurface environments, including environments such as those of Fig. 1.

[0046] In Fig. 2, the sedimentary basin 210, which is a geologic environment, includes horizons, faults, one or more geobodies and facies formed over some period of geologic time. These features are distributed in two or three

dimensions in space, for example, with respect to a Cartesian coordinate system (e.g., x, y and z) or other coordinate system (e.g., cylindrical, spherical, etc.). As shown, the model building method 220 includes a data acquisition block 224 and a model geometry block 228. Some data may be involved in building an initial model and, thereafter, the model may optionally be updated in response to model output, changes in time, physical phenomena, additional data, etc. As an example, data for modeling may include one or more of the following: depth or thickness maps and fault geometries and timing from seismic, remote-sensing, electromagnetic, gravity, outcrop and well log data. Furthermore, data may include depth and thickness maps stemming from facies variations (e.g., due to seismic unconformities) assumed to following geological events (“iso” times) and data may include lateral facies variations (e.g., due to lateral variation in sedimentation characteristics).

[0047] To proceed to modeling of geological processes, data may be provided, for example, data such as geochemical data (e.g., temperature, kerogen type, organic richness, etc.), timing data (e.g., from paleontology, radiometric dating, magnetic reversals, rock and fluid properties, etc.) and boundary condition data (e.g., heat-flow history, surface temperature, paleowater depth, etc.).

[0048] In basin and petroleum systems modeling, quantities such as temperature, pressure and porosity distributions within the sediments may be modeled, for example, by solving partial differential equations (PDEs) using one or more numerical techniques. Modeling may also model geometry with respect to time, for example, to account for changes stemming from geological events (e.g., deposition of material, erosion of material, shifting of material, etc.).

[0049] The aforementioned commercially available modeling framework marketed as the PETROMOD® framework (Schlumberger Limited, Houston, Texas) includes features for input of various types of information (e.g., seismic, well, geological, etc.) to model evolution of a sedimentary basin. The PETROMOD® framework provides for petroleum systems modeling via input of

various data such as seismic data, well data and other geological data, for example, to model evolution of a sedimentary basin. The PETROMOD® framework may predict if, and how, a reservoir has been charged with hydrocarbons, including, for example, the source and timing of hydrocarbon generation, migration routes, quantities, pore pressure and hydrocarbon type in the subsurface or at surface conditions. In combination with a framework such as the PETREL® framework, workflows may be constructed to provide basin-to-prospect scale exploration solutions. Data exchange between frameworks can facilitate construction of models, analysis of data (e.g., PETROMOD® framework data analyzed using PETREL® framework capabilities), and coupling of workflows. As an example, the TECHLOG® framework may be implemented in a workflow, for example, using one or more features for petrophysics (core and log), geology, drilling, reservoir and production engineering, and geophysics.

[0050] As shown in Fig. 2, the formation 230 includes a horizontal surface and various subsurface layers. As an example, a borehole may be vertical. As another example, a borehole may be deviated. In the example of Fig. 2, the borehole 235 may be considered a vertical borehole, for example, where the z-axis extends downwardly normal to the horizontal surface of the formation 230. As an example, a tool 237 may be positioned in a borehole, for example, to acquire information. As mentioned, a borehole tool can include one or more sensors that can acquire borehole images via one or more imaging techniques. A data acquisition sequence for such a tool can include running the tool into a borehole with acquisition pads closed, opening and pressing the pads against a wall of the borehole, delivering electrical current into the material defining the borehole while translating the tool in the borehole, and sensing current remotely, which is altered by interactions with the material.

[0051] As an example, data can include geochemical data. For example, consider data acquired using X-ray fluorescence (XRF) technology, Fourier

transform infrared spectroscopy (FTIR) technology and/or wireline geochemical technology.

[0052] As an example, one or more probes may be deployed in a bore via a wireline or wirelines. As an example, a probe may emit energy and receive energy where such energy may be analyzed to help determine mineral composition of rock surrounding a bore. As an example, nuclear magnetic resonance may be implemented (e.g., via a wireline, downhole NMR probe, etc.), for example, to acquire data as to nuclear magnetic properties of elements in a formation (e.g., hydrogen, carbon, phosphorous, etc.).

[0053] As an example, lithology scanning technology may be employed to acquire and analyze data. For example, consider the commercially available LITHO SCANNER™ technology marketed by Schlumberger Limited (Houston, Texas). As an example, a LITHO SCANNER™ tool may be a gamma ray spectroscopy tool.

[0054] As an example, a tool may be positioned to acquire information in a portion of a borehole. Analysis of such information may reveal vugs, dissolution planes (e.g., dissolution along bedding planes), stress-related features, dip events, etc. As an example, a tool may acquire information that may help to characterize a fractured reservoir, optionally where fractures may be natural and/or artificial (e.g., hydraulic fractures). Such information may assist with completions, stimulation treatment, etc. As an example, information acquired by a tool may be analyzed using a framework such as the aforementioned TECHLOG® framework (Schlumberger Limited, Houston, Texas).

[0055] As an example, a workflow may utilize one or more types of data for one or more processes (e.g., stratigraphic modeling, basin modeling, completion designs, drilling, production, injection, etc.). As an example, one or more tools may provide data that can be used in a workflow or workflows that may implement one or more frameworks (e.g., PETREL®, TECHLOG®, PETROMOD®, etc.).

[0056] As to the convention 240 for dip, as shown in Fig. 2, the three dimensional orientation of a plane can be defined by its dip and strike. Dip is the angle of slope of a plane from a horizontal plane (e.g., an imaginary plane) measured in a vertical plane in a specific direction. Dip may be defined by magnitude (e.g., also known as angle or amount) and azimuth (e.g., also known as direction). As shown in the convention 240 of Fig. 2, various angles α indicate angle of slope downwards, for example, from an imaginary horizontal plane (e.g., flat upper surface); whereas, dip refers to the direction towards which a dipping plane slopes (e.g., which may be given with respect to degrees, compass directions, etc.). Another feature shown in the convention of Fig. 2 is strike, which is the orientation of the line created by the intersection of a dipping plane and a horizontal plane (e.g., consider the flat upper surface as being an imaginary horizontal plane).

[0057] Some additional terms related to dip and strike may apply to an analysis, for example, depending on circumstances, orientation of collected data, etc. One term is “true dip” (see, e.g., Dip_T in the convention 240 of Fig. 2). True dip is the dip of a plane measured directly perpendicular to strike (see, e.g., line directed northwardly and labeled “strike” and angle α_{\perp}) and also the maximum possible value of dip magnitude. Another term is “apparent dip” (see, e.g., Dip_A in the convention 240 of Fig. 2). Apparent dip may be the dip of a plane as measured in any other direction except in the direction of true dip (see, e.g., α_A as Dip_A for angle α); however, it is possible that the apparent dip is equal to the true dip (see, e.g., α as $Dip_A = Dip_T$ for angle α_{\perp} with respect to the strike). In other words, where the term apparent dip is used (e.g., in a method, analysis, algorithm, etc.), for a particular dipping plane, a value for “apparent dip” may be equivalent to the true dip of that particular dipping plane.

[0058] As shown in the convention 240 of Fig. 2, the dip of a plane as seen in a cross-section perpendicular to the strike is true dip (see, e.g., the surface with α as $Dip_A = Dip_T$ for angle α_{90} with respect to the strike). As indicated, dip

observed in a cross-section in any other direction is apparent dip (see, e.g., surfaces labeled Dip_A). Further, as shown in the convention 240 of Fig. 2, apparent dip may be approximately 0 degrees (e.g., parallel to a horizontal surface where an edge of a cutting plane runs along a strike direction).

[0059] In terms of observing dip in wellbores, true dip is observed in wells drilled vertically. In wells drilled in any other orientation (or deviation), the dips observed are apparent dips (e.g., which are referred to by some as relative dips). In order to determine true dip values for planes observed in such boreholes, as an example, a vector computation (e.g., based on the borehole deviation) may be applied to one or more apparent dip values.

[0060] As mentioned, another term that finds use in sedimentological interpretations from borehole images is “relative dip” (e.g., Dip_R). A value of true dip measured from borehole images in rocks deposited in very calm environments may be subtracted (e.g., using vector-subtraction) from dips in a sand body. In such an example, the resulting dips are called relative dips and may find use in interpreting sand body orientation.

[0061] A convention such as the convention 240 may be used with respect to an analysis, an interpretation, an attribute, etc. (see, e.g., various blocks of the system 100 of Fig. 1). As an example, various types of features may be described, in part, by dip (e.g., sedimentary bedding, faults and fractures, cuestas, igneous dikes and sills, metamorphic foliation, etc.). As an example, dip may change spatially as a layer approaches a geobody. For example, consider a salt body that may rise due to various forces (e.g., buoyancy, etc.). In such an example, dip may trend upward as a salt body moves upward.

[0062] Seismic interpretation may aim to identify and/or classify one or more subsurface boundaries based at least in part on one or more dip parameters (e.g., angle or magnitude, azimuth, etc.). As an example, various types of features (e.g., sedimentary bedding, faults and fractures, cuestas, igneous dikes and sills,

metamorphic foliation, etc.) may be described at least in part by angle, at least in part by azimuth, etc.

[0063] As an example, equations may be provided for petroleum expulsion and migration, which may be modeled and simulated, for example, with respect to a period of time. Petroleum migration from a source material (e.g., primary migration or expulsion) may include use of a saturation model where migration-saturation values control expulsion. Determinations as to secondary migration of petroleum (e.g., oil or gas), may include using hydrodynamic potential of fluid and accounting for driving forces that promote fluid flow. Such forces can include buoyancy gradient, pore pressure gradient, and capillary pressure gradient.

[0064] As shown in Fig. 2, the system 250 includes one or more information storage devices 252, one or more computers 254, one or more networks 260 and instructions 270. As to the one or more computers 254, each computer may include one or more processors (e.g., or processing cores) 256 and memory 258 for storing instructions, for example, consider the instructions 270 as including instructions executable by at least one of the one or more processors. As an example, a computer may include one or more network interfaces (e.g., wired or wireless), one or more graphics cards (e.g., one or more GPUs, etc.), a display interface (e.g., wired or wireless), etc. As an example, imagery such as surface imagery (e.g., satellite, geological, geophysical, etc.) may be stored, processed, communicated, etc. As an example, data may include SAR data, GPS data, etc. and may be stored, for example, in one or more of the storage devices 252.

[0065] As an example, the instructions 270 may include instructions (e.g., stored in memory) executable by one or more processors to instruct the system 250 to perform various actions. As an example, the system 250 may be configured such that the instructions 270 provide for establishing the framework 170 of Fig. 1 or a portion thereof. As an example, one or more methods,

techniques, etc. may be performed at least in part via instructions, which may be, for example, instructions of the instructions 270 of Fig. 2.

[0066] As an example, a framework can include various components. For example, a framework can include one or more components for prediction of reservoir performance, one or more components for optimization of an operation or operations, one or more components for control of production engineering operations, etc. As an example, a framework can include components for prediction of reservoir performance, optimization and control of production engineering operations performed at one or more reservoir wells. Such a framework may, for example, allow for implementation of various methods. For example, consider an approach that allows for a combination of physics-based and data-driven methods for modeling and forecasting a reservoir production.

[0067] Fig. 3 shows an example of a method 300 that includes a reception block 310 for receiving information, a prediction block 320 for predicting a condition or conditions and an output block 330 for outputting information based at least in part on a predicted condition or conditions. In such an example, the prediction block 320 can include, for example, predicting one or more conditions associated with production of fluid from a reservoir, and the output block 330 can include, for example, outputting information that controls one or more operations associated with production of fluid from the reservoir. As an example, the reception block 310 can include receiving information associated with one or more reservoirs.

[0068] As an example, the method 300 of Fig. 3 may include implementing one or more algorithms, which may be or include, for example, one or more prediction algorithms (e.g., machine-learning based prediction algorithms, etc.). As an example, the method 300 of Fig. 3 may include one or more training algorithms.

[0069] As an example, a framework can implement machine learning, for example, as a method that can devise one or more algorithms that can be utilized

for generating predictions. In such an example, an algorithm may be a model based algorithm where, for example, a model may be formulated, adjusted, etc. and utilized, at least in part, to predict one or more conditions, which may be or include one or more future conditions (e.g., a condition that may occur and that may be characterized by a likelihood of occurrence, optionally contingent on occurrence of one or more other conditions). A framework may provide relatively reliable and repeatable predictions and, for example, may help to uncover insights through learning (e.g., from historical relationships, trends in data, etc.).

[0070] As to learning, a framework may implement one or more types of learning. For example, consider one or more of decision tree learning, association rule learning, artificial neural network (ANN) learning, deep learning (e.g., multiple hidden layers in an artificial neural network, etc.), inductive logic programming (ILP) learning, support vector machines (SVM) learning (e.g., a set of related supervised learning methods used for classification and regression), cluster analysis learning, Bayesian network learning (e.g., a belief network or directed acyclic graphical model that includes a probabilistic graphical model that represents a set of random variables and their conditional independencies via a directed acyclic graph (DAG), etc.), reinforcement learning (e.g., how an agent ought to take actions in an environment so as to maximize some notion of long-term reward, etc.), representation learning (e.g., to discover representations of inputs provided during training, etc.), manifold learning (e.g., low-dimensional space, etc.), similarity and/or metric learning (e.g., learning a similarity function (or a distance metric function) that can predict if items are similar/dissimilar), sparse dictionary learning (e.g., a datum represented as a linear combination of basis functions), and genetic learning (e.g., a search heuristic that mimics a process of natural selection via mutation and/or crossover).

[0071] The method 300 is shown in Fig. 3 in association with various computer-readable media blocks 311, 321 and 331 (e.g., non-transitory media

that are not carrier waves and that are not signals). Such blocks generally include instructions suitable for execution by one or more processors (or cores) to instruct a computing device or system to perform one or more actions. While various blocks are shown, a single medium may be configured with instructions to allow for, at least in part, performance of various actions of the method 300. A computer-readable medium can be a non-transitory computer-readable storage medium that is not a carrier wave. As an example, one or more computer-readable medium blocks may be provided for graphical user interfaces (GUIs), etc.

[0072] As an example, a framework can be part of a cognitive advisory system. For example, consider a cognitive advisory system (CAS) for prediction, optimization, and/or control of reservoir performance. As an example, a CAS may utilize simulation data and/or real field data. As an example, a CAS may be a self-learning computer system that can run in one or more modes such as, for example, an online machine learning (e.g., optionally a slow background mode) and an operational mode (e.g., optionally a fast optimization/prediction/control mode). As an example, a CAS may periodically and/or continuously improve expertise (e.g., in a machine learning mode), which can act to improve accuracy (e.g., of an operational mode). As an example, a CAS may periodically and/or continuously renew one or more databases, for example, by accounting for various impacts on one or more reservoirs linked with one or more applications (e.g., of different technologies), which may be associated with one or more reservoir wells (e.g., consider fracturing, well intervention, artificial lift systems deployment, intelligent completions deployment, etc.). As an example, a CAS may receive non-technology information relevant to a reservoir or reservoirs, which may be analyzed and maintained in as internal knowledge and/or as one or more information database (e.g., market, economics, local specific knowledge, climate, etc.). As an example, price of oil can be non-technology information that can be utilized to make one or more technology-related predictions, control

actions, etc. For example, the price of oil can be utilized in determining a water-oil ratio (WOR) or water fraction of fluid produced from one or more wells (e.g., a proxy for an economic limit) that can be utilized by a CAS to output information associated with operations in a field and/or to change a state of operation of the CAS itself. As an example, a CAS may allow for generation of short, medium and/or long term recommendations on production optimization based on one or more of comparative analysis of reservoir development scenario and immediate smart data mining within historical reservoir performance. As an example, a CAS may allow for generation of recommendations for control actions to prevent hazardous situations, mitigate risks and/or to provide planned production volume and rates.

[0073] As an example, a CAS may be implemented for prediction, optimization, and/or control of performance of an oil and gas reservoir. In such an example, the CAS may discover knowledge through interactions with various kinds of input data (e.g., real, synthetic, etc.), and improve its prediction accuracy.

[0074] As an example, a workflow or workflows may include various interactions such as, for example, interactions between one or more of machine learning component(s), integrated data-driven and physics-driven modeling tools, an optimization engine, and an interactive knowledge database. Such features may be components of a framework such as, for example, a CAS framework.

[0075] Fig. 4 shows an example of a system 400 (e.g., a CAS) that includes an input component 410, a database component 420, an algorithm component 430, a tool component 440, a predictor component 460 and an output component 480. In the example system 400, various examples of links are illustrated, which may include, for example, a data exchange and/or triggering link, a simulation link, a learning and/or training link and a feedback link.

[0076] Fig. 4 also shows an example of a method where an input block 491 can include receiving information, a prediction block 496 can include predicting

one or more conditions and an output block 498 can include outputting information based at least in part on at least one predicted condition.

[0077] As an example, a CAS can include the database component 420, the algorithm component 430 (e.g., a machine learning component) and the predictor component 460, which may be components of a framework (e.g., a CAS framework). In such an example, the CAS can receive information as input and can transmit information as output. As an example, such a CAS may be utilized to implement at least a portion of the method 490 of Fig. 4 (e.g., for predicting one or more conditions).

[0078] The illustrated example system 400 of Fig. 4 includes various links that can represent a high-level workflow of the system 400, for example, for prediction optimization, and/or control of performance of an oil and gas reservoir. As an example, the system 400 may include features to adjust a reservoir model. As an example, a reservoir model may be received as input and stored digitally in a database of the system 400 where the reservoir model may be accessed by a reservoir simulation framework and/or transmitted to a reservoir simulation framework. As an example, such a database may store versions of a reservoir model during the course of operations of the system 400 where one or more of the versions may be adjusted via operation of the system 400 and then utilized by the reservoir simulation framework.

[0079] As an example, a system can receive a block of input data (e.g., which may include one or more of a reservoir description, streaming data from one or more sensors, production data, technology description, human perception of technology efficiency at a particular well/reservoir/geology, market data, environmental data, human-defined scenario for a field development plan, etc.). In such an example, the input data may be stored in a smart database. As an example, a smart database can be used for training one or more machine learning algorithms that can provide for outputting various predictions tools for modeling different field (reservoir) characteristics. As an example, a set of prediction tools

may include software for production prediction, field development plan (FDP) optimization, production control, and reservoir model adjustment. As an example, a smart database may be periodically and/or continuously updated by knowledge generated by a system. As an example, output of a system may be generated as one or several types of output such as, for example, one or more of optimal scenario(s) for field development with uncertainty estimation, FDP at a pre-defined condition and/or conditions, immediate advice on short term optimization of a production process, an adjusted reservoir model, etc.

[0080] As an example, a scenario can include fluids debit forecasting with regard to a plan of technological operations to be applied for a field. In such an example, consider one or more types of plans such as, for example, a water-flooding plan, a completions deployment plan, a plan of artificial lift system(s) implementation, a plan of well stimulation, an enhanced oil recovery (EOR) implementation plan, an optimal chocking sequence plan, etc.

[0081] As to water-flooding, water is injected into an oil reservoir formation to displace residual oil. Water from one or more injection wells can physically sweep oil to one or more production wells. Water-flooding techniques can be enhanced with understanding of variable permeability or one or more other conditions that can affect fluid transport within a reservoir formation. As an example, a CAS may facilitate development of a water-flooding plan that aims to diminish risk of early water breakthrough, which can cause production and surface processing problems. A reservoir model and simulator can be utilized to optimize a plan where the reservoir model and simulator may be implemented as part of a CAS. As to water-flooding, positions of injection wells may be optimized as well as, for example, water flow rates over time for one or more injection wells.

[0082] As an example, at a learning stage, a system may communicate with one or more reservoir modeling and/or optimization tools. As an example, after

sufficient learning, a system may implement various workflows that may occur optionally without additional learning.

[0083] As an example, a CAS can include one or more artificial intelligence (AI) components, which may be, for example, prediction components. As an example, a CAS can include a set of machine learning and prompt prediction tools aimed at different aspects of forward and inverse modeling of various processes related to well and reservoir performance where, for example, a smart database may provide for storing knowledge and data relevant to a reservoir or reservoirs. As an example, where a CAS is directed to a reservoir, it may be referred to as a cognitive reservoir system (CRS).

[0084] As an example, one or more components of the CAS 400 may be implemented in a cloud environment. For example, the algorithm component 430 and the predictor component 460 may be components of a framework (e.g., CAS, CRS, a cognitive fracturing system (CFS), etc.) that operate using computing, communication and data storage resources of a cloud environment, which may be structured via a cloud architecture. As an example, the method 490 may be implemented at least in part in a cloud environment. As an example, a cloud environment may be organized at least in part by one or more cloud architectures.

[0085] Fig. 5 shows an example of a cloud architecture 500, which corresponds to the AZURE™ platform architecture (Microsoft Corporation, Redmond, Washington). As shown, the architecture 500 includes a client layer 510, an integration layer 520, an application layer 540 and a data layer 540. The client layer 510 can include features for one or more types of computing device, which may be information handling devices (e.g., desktop computers, workstations, smartphones, tablets, notebook computers, etc.). The integration layer 520 can provide logistics as to Web-based connections and communications with the client layer 510 and with the application layer 530 and/or the data layer 540. As shown, the integration layer 520 can include a content delivery network

(CDN), a traffic manager, data synchronization services for servicing operations with respect to one or more databases, etc.

[0086] As shown in the example of Fig. 5, the application layer 530 can include media services and compute resources, which can include Web role, worker role and virtual machine (VM) role compute resources, which can be operatively coupled to the data layer 540. As an example, the application layer 530 can include HADOOP™ services (Apache Software Foundation, Forest Hills, Maryland), which are provided via a framework that can facilitate distributed storage and processing of large data sets, for example, via one or more computer clusters. Such services may handle hardware failures occurrences in an automated manner to help assure availability of data, etc.

[0087] As shown in Fig. 5, the data layer 540 can include various data storage features (e.g., drives, blobs, tables, queues, etc.), caching features and database access features (e.g., SQL, etc.).

[0088] As an example, a cloud computing platform can be utilized to implement a cloud-based system. For example, consider the AZURE™ platform (Microsoft Corporation, Redmond, Washington), which is a cloud computing platform and infrastructure for building, deploying, and managing applications and services through a global network of data centers.

[0089] A cloud computing platform can offer, for example, virtual machines, infrastructure as a service (IaaS) that provide for launch of virtual machines and/or preconfigured machine images, App services, a platform as a service (PaaS) environment (e.g., to publish and/or manage Web sites), Websites, high density hosting of websites (e.g., optionally using one or more of ASP.NET, PHP, Node.js, Python, etc.), etc. As an example, a cloud-based system may utilize Websites in PHP, ASP.NET, Node.js, Python, or one or more other languages. As an example, a cloud computing platform may offer WebJobs as applications that can be deployed to a Web App to implement background processing. Such an approach may be invoked on a schedule, on-demand and/or

run continuously. As an example, a cloud computing platform may offer blob (data storage/structure), table and queue services, which may be utilized to communicate between Web Apps and WebJobs and, for example, to provide state information.

[0090] A cloud computing platform can provide one or more of SaaS, PaaS and IaaS services and, for example, supports different programming languages, tools and frameworks.

[0091] As mentioned, cloud services can dynamically scale, for example, to meet demands of users. Provisioning may be automated in a cloud environment where a cloud infrastructure provider supplies hardware and software.

[0092] As an example, a cloud environment can provide an “Internet of Things” (IoT) hub. For example, an IoT hub can provide for adding devices, connecting to existing devices, using device SDKs for multiple platforms, including LINUX® OS, WINDOWS® OS, and real-time operating systems (RTOSs). As an example, an IoT hub can scale from just a few devices (e.g., sensors, etc.) to hundreds of simultaneously connected devices (e.g., sensors, etc.) with distributed availability of the cloud.

[0093] As an example, a device can be a sensor device, a control device, or other device that may include an embedded microcontroller with an operating system (e.g., a RTOS, etc.). As an example, a device can include communication circuitry that allows for communication via one or more protocols. For example, consider BLUETOOTH® communication circuitry that communicates via a BLUETOOTH® protocol, WIFI communication circuitry that communicates via an Internet protocol (IP), GSM communication circuitry, etc.

[0094] As an example, a field site may be instrumented with various types of devices that include communication circuitry that allows for access via a network or networks that includes the Web or that is operatively coupled to the Web. As an example, a field site may be a seismic survey field site, a rigsite, a hydraulic fracturing site, a production site, etc. A field may be developed at least

in part according to a field development plan (FDP). As an example, a rigsite can be a wellsite where a well exists, as may be drilled according to a well plan, which can be part of a FDP. For example, a well plan can specify a well trajectory and optionally completion specifications. As an example, a well plan may specify a treatment such as a stimulation treatment. Various types of equipment can be present at a rigsite, which may be a wellsite, where such equipment can be control and/or sensor equipment that can form part of an IoT infrastructure at the site.

[0095] Fig. 6 shows an example of a CAS 600 that includes an input component 610, a database component 620, an algorithm component 630 (e.g., a machine learning component), a tool component 640, a predictor component 660 and an output component 680. In the example CAS 600, various examples of links are illustrated, which may include, for example, a data exchange and/or triggering link, a simulation link, a learning and/or training link and a feedback link.

[0096] As an example, the CAS 600 may be implemented at least in part as to one or more workflows. As an example, the database component 620, the algorithm component 630 (e.g., a machine learning component) and the predictor component 660 may be implemented at least in part as to one or more workflows. As an example, the CAS 600 may be characterized along a scale as to a partial scale implementation to a full scale implementation. For example, one or more of the features of the CAS 600 may be optionally with respect to one or more workflows.

[0097] As an example, the CAS 600 can be a computer system with continuously improving accuracy in a machine learning mode for prediction, optimization, and control of performance of an oil and gas reservoir.

[0098] Fig. 6 shows a legend as to initial data, live data (e.g., real-time data), portions of a cognitive system, an initial development scenario (e.g., as input from a user or users, etc.), outcomes (e.g., one or more output conditions), and tools (e.g., tools or frameworks).

[00099] As an example, initial data (e.g., available before exploitation of CRS at an oilfield) can include results of reservoir modeling (e.g., via the ECLIPSE® simulator, a PETREL® model, etc.), an initial field development plan (FDP), and accumulated data on history of production and/or history of technology treatment.

[00100] As an example, live data (e.g., available after initiation of a CRS exploitation) can include streaming production and/or sensor data, technology application data and non-technical information (e.g., market conditions, climate impact, etc.).

[00101] As an example, a development scenario from a user (e.g., a reservoir treatment scenario) can include a particular sequence of actions (e.g., optionally including actions in parallel) that can be applied to an oilfield to be examined by a CRS in various (e.g., optionally user-defined) modes of a CRS operation (e.g., consider a CRS as a simulator or a CRS as a predictive data analytics system).

[00102] As an example, input information blocks may communicate with a knowledge and information data storage through, for example, a data analyzer. As an example, a smart database can be a storage device or devices for data from available sources (e.g., consider real data, modeling results and “lessons learned” from a technology application and/or actions taken as to reservoir development, operation, etc.).

[00103] As an example, a data analyzer may include one or more artificial intelligence (AI) tools, for example, consider AI tool(s) for one or more of cleaning, deduping, matching, fuzzy matching, filtering, structuring data, estimating quality and/or value, etc. As an example, a knowledge and information data storage may provide access to data to one or more different machine learning blocks, for example, in a suitable form for the one or more blocks. As an example, access may be via a database management platform. As an example, a STUDIO™ framework (Schlumberger Ltd., Houston, Texas) may

be utilized such as, for example, features of the STUDIO™ FIND search framework (Schlumberger Ltd., Houston, Texas).

[00104] As an example, a framework may be operatively coupled to a search engine that can provide for searching one or more data stores (e.g., databases, etc.). As an example, the STUDIO E&P™ knowledge environment (Schlumberger Ltd., Houston, Texas) includes STUDIO FIND™ search functionality, which provides a search engine. The STUDIO FIND™ search functionality also provides for indexing content, for example, to create one or more indexes. As an example, search functionality may provide for access to public content, private content or both, which may exist in one or more databases, for example, optionally distributed and accessible via an intranet, the Internet or one or more other networks. As an example, a search engine may be configured to apply one or more filters from a set or sets of filters, for example, to enable users to filter out data that may not be of interest.

[00105] As an example, an analyzer may provide for analyzing one or more items. As an example, the PETREL® seismic-to-simulation framework (Schlumberger Ltd., Houston, Texas) may provide for interaction with an analyzer and, for example, a search engine that may include associated features such as features of the STUDIO FIND™ search functionality. As an example, a framework may provide for implementation of one or more spatial filters (e.g., based on an area viewed on a display, static data, etc.). As an example, a search may provide access to dynamic data (e.g., “live” data from one or more sources, optionally including a GIS source), which may be available via one or more networks (e.g., wired, wireless, etc.).

[00106] As an example, an algorithm component can include one or more algorithms that may be utilized to perform machine learning (ML). For example, consider one or more algorithms associated with production prediction, optimization, control, and/or inversion. As an example, a system can include learning and prediction tools (e.g., which may be, from an implementation

viewpoint, representative of different running modes of a framework, a system, etc.).

[00107] As an example, a learning tool can be associated with a training set (TS), for example, accessible via a data storage. As an example, TSs may be used for building one or more corresponding prediction models. As an example, a TS may be subdivided on historical data including initial and live information (e.g., from a smart database), and on synthetic data (e.g., obtained from modeling and stored in smart database). In such an example, the latter data may be generated by two or more different sources depending on a particular ML block.

[00108] As an example, a ML production prediction component may utilize one or more training sets optionally with one or more of historical data and synthetic data, which may be generated by a reservoir modeling tool (e.g., the ECLIPSE® simulator, etc.) for building a model that can be called by a prompt reservoir performance predictor. In such an example, the predictor can act as a fast data-driven tool for forecasting reservoir behavior, for example, as to one or more different development scenarios.

[00109] As an example, a predictor can include one or more relatively simplistic physical models of a well or wells (see, e.g., Kaviani et al., How accurate are Capacitance Model connectivity estimates?, *Journal of Petroleum Science and Engineering*, Volume 122, October 2014, Pages 439–452; and Artun, Characterizing interwell connectivity in waterflooded reservoirs using data-driven and reduced-physics models: a comparative study, *Neural Computing and Applications*, pp. 1-15, January 2016). In such an example, a reservoir performance predictor may utilize a reservoir model for training and output of a set of coefficients for one or more systems of physics-based equations (e.g., capacity resistance model -like approaches). As an example, machine learning can include deep learning (see, e.g., Deng et al., “Deep Learning: Methods and Applications”, *Foundations and Trends in Signal Processing* 7: 3-4, 2014), for example, with one or more multi-layered artificial neural networks.

[00110] As an example, machine learning (ML) optimization can allow for prediction of an optimal strategy for reservoir treatment with regard to particular production characteristics (e.g., cumulative oil production within a given time period). As an example, historical data and synthetic data may be utilized in one or more training sets (TSs) in one or more machine learning (ML) blocks. As an example, synthetic data can include numerous automatically generated scenarios of field development with a wide range of potential technology impacts (e.g., reservoir treatment scenarios) and corresponding output from a prompt production prediction model. As an example, to help mitigate uncertainty of a considered optimization problem, filtration of different scenarios that correspond to similar production characteristics can be performed for forming one or more training sets (e.g., optionally with intervention of an experienced operator, etc.). As an example, knowledge acquired by ML optimization can be a basis for building a prompt optimization model for evaluating one or more outcomes of a cognitive system (e.g., consider an optimal treatment scenario).

[00111] As an example, one or more learning algorithms described in Mohri et al. (Foundations of Machine Learning, The MIT Press ISBN 9780262018258, 2012) may be utilized in a ML component or components. As an example, an optimization component (e.g., as implemented in the PETREL® framework, MEPO™ framework (Schlumberger Limited, Houston Texas), etc.) may be utilized to enhance performance of prompt optimization and, for example, help to avoiding a huge amount of playable scenarios while forming one or more synthetic training sets (TSs).

[00112] As an example, a ML control component can allow for advising as to one or more immediate control actions, for example, on a basis of streaming production and sensor information and/or other live data. As an example, a training set (TS) for a ML control component can include historical CRS input data and one or more synthetic scenarios from a data storage, for example, that

may be deemed to be similar to a real one and to an optimal treatment scenario suggested by a ML optimization block.

[00113] As an example, knowledge acquired by ML control (see, e.g., the prompt control and/or risk management block of the predictor 660 of the CAS 600 of Fig. 6) can be, at least in part, utilized as a basis for building a prompt control model. In such an example, the model may generate particular immediate action advice (e.g., an output of a CRS). As an example, action advice can be or pertain to one or more conditions. For example, action advice may be a control condition, an operational condition, etc. As an example, tactical actions for one or more wells can include one or more of choke closure/opening actions, application of a definite fracturing operation, an ESP pump replacement with a rod pump action, a water insulation operation on a smart completion system, etc.

[00114] As an example, connection to a prompt production predictor can allow for double checking one or more predictions and, for example, generation of one or more absent synthetic scenarios (e.g., for training, etc.). As an example, a ML control component can run in a training mode (e.g., on a selected basis such that it operates permanently in such a mode for a reservoir, etc.). In such an example, a ML control component may utilize, for example, an association rule learning approach (see, e.g., Agrawal et al., "Mining association rules between sets of items in large databases". Proceedings of the 1993 ACM SIGMOD international conference on Management of data - SIGMOD '93. p. 207, 1993), artificial neural networks (see, e.g., Deng et al.) and/or decision tree learning (see, e.g., Rokach et al., Data mining with decision trees: theory and applications. World Scientific Pub Co Inc. ISBN 978-9812771711, 2008).

[00115] As an example, a ML inversion component may utilize one or more of historical production data, new geological data, and reservoir modeling results as a training set or training sets, for example, to generate a reservoir model adjuster.

[00116] As an example, a reservoir model adjuster may allow for refinement of one or more governing parameters of a reservoir model, for example, to improve predictive ability of modeling. As an example, a ML inversion component can be a kind of interpretation system that can utilize one or more elements of inverse problem approaches (see, e.g., Tarantola, *Inverse Problem Theory*, SIAM, 2005) and/or data mining possibilities that may include inductive learning (see, e.g., Shapiro, *Inductive inference of theories from facts*, Research Report 192, Yale University, Department of Computer Science, 1981. Reprinted in J.-L. Lassez, G. Plotkin (Eds.), *Computational Logic*, The MIT Press, Cambridge, MA, 1991, pp. 199–254) programming and/or association rule learning approach (see, e.g., Agrawal et al.).

[00117] As an example, components can include ML components. For example, a system can include four ML components as illustrated in the example system 600 of Fig. 6. As an example, such components may operate in a training mode, for example, in accordance with one or more online learning approaches (see e.g., Shai Shalev-Shwartz, “Online Learning and Online Convex Optimization”, *Foundations and Trends® in Machine Learning: Vol. 4: No. 2*, pp 107-194. <http://dx.doi.org/10.1561/22000000018>, 2012), for example, to provide continuously increased reliability of one or more ML prediction models. As an example, corresponding TSs may be periodically and/or continuously fulfilling, for example, via live data and/or generated synthetic data (e.g., consider automatically generated synthetic data).

[00118] As an example, a output component or components can include information germane to one or more of an actual FDP, an optimal treatment scenario, immediate action advice, and/or an adjusted reservoir model (e.g., in a user-friendly manner and/or in an internal CRS form for accumulation in a smart data base, etc.).

[00119] As an example, components of a CRS can include one or more components that can generate an optimal long term (e.g., about one year or more

as a time horizon) production operation plan for an oilfield; that can generate prompt advice as to what to adjust in reservoir production to enhance desired parameters of a reservoir in a short term (e.g., about one day to about several months as a time horizon); that can self-check for consistency of input and generated data, for example, to help diminish risk of one or more misleading predictions; that can optionally be utilized independently (e.g., consider a prompt reservoir performance predictor, adjusters, an optimizer, etc.); and that can provide for continuous updating, for example, with new live data and/or physical modeling data (e.g., to produce new knowledge and/or to refine one or more prediction models).

[00120] As an example, variations can exist for a workflow associated with the CAS 600 of Fig. 6. For example, Figs. 7, 8, 9, 10, 11 and 12 provide examples of systems 700, 800, 900, 1000, 1100 and 1200, which may optionally be implementations of components of the CAS 600 of Fig. 6. As an example, the systems 700, 800, 900, 1000, 1100 and 1200 of Figs. 7, 8, 9, 10, 11 and 12, respectively may be, for example, independent systems that include the particular features for implementing one or more workflows. The example systems 700, 800, 900, 1000, 1100 and 1200 of Figs. 7, 8, 9, 10, 11 and 12 are illustrated with respect to arrows, which represent links, as described, for example, in legends of Figs. 7, 8, 9, 10, 11 and 12.

[00121] Fig. 7 shows an example of a system 700 that includes an input component 710, a database component 720, an algorithm component 730, a tool component 740, a predictor component 760 and an output component 780. In the example system 700, various examples of links are illustrated, which may include, for example, a data exchange and/or triggering link, a simulation link, a learning and/or training link and a feedback link. As an example, the system 700 may be implemented at least in part as to one or more workflows. As an example, the database component 720, the algorithm component 730 and the predictor component 760 (e.g., as components of a cognitive system) may be implemented

at least in part as to one or more workflows. In the example of Fig. 7, a data analyzer and a smart database and a machine learning production predictor can allow for prompt production modeling, for example, optionally with continuously improving accuracy. As an example, the system 700 can include a CRS with capability for prompt reservoir performance prediction. As shown, the system 700 can output a field development plan (FDP) based at least in part on a prompt reservoir performance prediction.

[00122] Fig. 8 shows an example of a system 800 that includes an input component 810, a database component 820, an algorithm component 830, a tool component 840, a predictor component 860 and an output component 880. In the example system 800, various examples of links are illustrated, which may include, for example, a data exchange and/or triggering link, a simulation link, a learning and/or training link and a feedback link. As an example, the system 800 may be implemented at least in part as to one or more workflows. As an example, the database component 820, the algorithm component 830 and the predictor component 860 (e.g., as components of a cognitive system) may be implemented at least in part as to one or more workflows. In the example of Fig. 8, the system 800 can include components for a data analyzer, a smart database, machine learning production prediction and machine learning optimization for prompt production modeling, for example, with continuously improving accuracy and long term prompt optimization, for example, with continuous improvement of uncertainty of scenario selection. As an example, the system 800 can be or include a CRS with capability for prompt performance prediction and long term optimization. In the example of Fig. 8, the system 800 can output a field development plan (FDP) and an optimal treatment scenario.

[00123] Fig. 9 shows an example of a system 900 that includes an input component 910, a database component 920, an algorithm component 930, a tool component 940, a predictor component 960 and an output component 980. In the example system 900, various examples of links are illustrated, which may

include, for example, a data exchange and/or triggering link, a simulation link, a learning and/or training link and a feedback link. As an example, the system 900 may be implemented at least in part as to one or more workflows. As an example, the database component 920, the algorithm component 930 and the predictor component 960 (e.g., as components of a cognitive system) may be implemented at least in part as to one or more workflows. In the example of Fig. 9, the system 900 can include one or more components for a data analyzer, a smart database, machine learning production prediction, and machine learning control for prompt production control, for example, with continuously improving accuracy. In the example of Fig. 9, the system 900 can be or include a CRS with short term production control functionality. As shown, the system 900 can output an immediate action as advice, which may be communicated via one or more networks to one or more destinations (e.g., one or more field equipment destinations, etc.). In such an example, an operator and/or equipment at a field location may take action according to the output of the system 900.

[00124] Fig. 10 shows an example of a system 1000 that includes an input component 1010, a database component 1020, an algorithm component 1030, a tool component 1040, a predictor component 1060 and an output component 1080. In the example system 1000, various examples of links are illustrated, which may include, for example, a data exchange and/or triggering link, a simulation link, a learning and/or training link and a feedback link. As an example, the system 1000 may be implemented at least in part as to one or more workflows. As an example, the database component 1020, the algorithm component 1030 and the predictor component 1060 (e.g., as components of a cognitive system) may be implemented at least in part as to one or more workflows. In the example of Fig. 10, the system 1000 can include one or more components for a data analyzer, a smart database, machine learning production prediction, machine learning inversion, reservoir model adjusting for performance prediction and adjustment of reservoir model functionality. In the

example of Fig. 10, the system 1000 can be or include a CRS for prompt performance prediction and adjustment of reservoir model functionality.

[00125] In the example of Fig. 10, the system 1000 can output an adjusted reservoir model. As shown, such an adjusted reservoir model can be based at least in part on machine learning-based prediction. As an example, an adjusted reservoir model may be utilized in a reservoir simulator (e.g., a tool) to generate simulation results, which may, in turn, be utilized for purposes of machine learning (e.g., by the algorithm component 1030) and further prediction (e.g., by the predictor component 1060). As shown in Fig. 10, feedback exists such that continuous learning can occur, which may benefit one or more workflows (e.g., one or more workflows that can be implemented by the CAS 600 of Fig. 6).

[00126] Fig. 11 shows an example of a system 1100 that includes an input component 1110, a database component 1120, an algorithm component 1130, a tool component 1140, a predictor component 1160 and an output component 1180. In the example system 1100, various examples of links are illustrated, which may include, for example, a data exchange and/or triggering link, a simulation link, a learning and/or training link and a feedback link. As an example, the system 1100 may be implemented at least in part as to one or more workflows. As an example, the database component 1120, the algorithm component 1130 and the predictor component 1160 (e.g., as components of a cognitive system) may be implemented at least in part as to one or more workflows. In the example of Fig. 11, the system 1100 can include one or more components for particular input (e.g., reservoir model, streaming production and/or sensor data and technology application data), a data analyzer, a smart database, and machine learning production prediction for production prediction, for example, optionally trained on a limited dataset. In the example of Fig. 11, the system 1100 can be or include a CRS trained on a limited dataset for production prediction.

[00127] As shown in Fig. 11, the system 1100 can output a field development plan (FDP), which can include one or more specified actions that can be implemented to develop a field. As shown, the FDP can be based at least in part on the prompt production prediction of the predictor component 1106. As an example, implementation of one or more FDP actions can result in changes to physical structures, fluids, etc., and result in data such as, for example, the streaming production and sensor data, which can be real-time data that is received by the data analyzer. In such an example, the system 1100 can continuously learn, which can increase accuracy, increase promptness, increase risk identification, etc. The workflow illustrated in Fig. 11 can increase performance of the CAS 600 of Fig. 6, optionally with respect to one or more other workflows.

[00128] Fig. 12 shows an example of a system 1200 that includes an input component 1210, a database component 1220, an algorithm component 1230, a tool component 1240, a predictor component 1260 and an output component 1280. In the example system 1200, various examples of links are illustrated, which may include, for example, a data exchange and/or triggering link, a simulation link, a learning and/or training link and a feedback link. As an example, the system 1200 may be implemented at least in part as to one or more workflows. As an example, the database component 1220, the algorithm component 1230 and the predictor component 1260 (e.g., as components of a cognitive system) may be implemented at least in part as to one or more workflows. In the example of Fig. 12, the system 1200 can include one or more components for input (e.g., live and historical real data), a data analyzer, a smart database and machine learning control for a control advisory tool that is based on real data. In the example of Fig. 12, the system 1200 can be or include a CRS for production control.

[00129] In the example of Fig. 12, the output of an immediate action as advice can be communicated to one or more destinations via one or more networks. As an example, a destination can be a field destination such as a rigsite

in a field. In such an example, the destination can be equipment that controls one or more field operations or can be a device such as a computer, a tablet, a smart phone, etc. Where the advised action is implemented in the field, one or more changes can occur, which can be structural changes, operational mode changes, etc. For example, where water-flooding is being implemented and an advised immediate action is to adjust a flow rate of water being injected into an injection well, an adjustment to the flow rate can cause a change in production of multiphase fluid at a production well, which may alter surface pipeline flow and/or processing at a processing facility (e.g., as to separation of the multiphase fluid to produce oil, etc.).

[00130] Fig. 13 shows an example of a geologic environment 1300 as including various types of equipment and features. As shown, the geologic environment 1300 includes a plurality of wellsites 1302 operatively connected to a processing facility 1354. In the example of Fig. 13, individual wellsites 1302 can include equipment that can form individual wellbores 1336 (e.g., rigs, etc.). Such wellbores can extend through subterranean formations 1306 including one or more reservoirs 1304. Such reservoirs 1304 can include fluids, such as hydrocarbons. As an example, wellsites can draw fluid from one or more reservoirs and pass them to one or more processing facilities via one or more surface networks 1344. As an example, a surface network can include tubing and control mechanisms for controlling flow of fluids from a wellsite to a processing facility.

[00131] Fig. 14 shows an example of portion of a geologic environment 1401 and an example of a larger portion of a geologic environment 1410. As shown, a geologic environment can include one or more reservoirs 1411-1 and 1411-2, which may be faulted by faults 1412-1 and 1412-2. Fig. 14 also shows some examples of offshore equipment 1414 for oil and gas operations related to the reservoirs 1411-1 and 1411-2 and onshore equipment 1416 for oil and gas

operations related to the reservoir 1411-1. As an example, a system may be implemented for operations associated with one or more of such reservoirs.

[00132] As to the geologic environment 1401, Fig. 14 shows a schematic view where the geologic environment 1401 can include various types of equipment. As shown in Fig. 14, the environment 1401 can include a wellsite 1402 and a fluid network 1444. The wellsite 1402 includes a wellbore 1406 extending into earth as completed and prepared for production of fluid from a reservoir 1411.

[00133] In the example of Fig. 14, wellbore production equipment 1464 extends from a wellhead 1466 of the wellsite 1402 and to the reservoir 1411 to draw fluid to the surface. As shown, the wellsite 1402 is operatively connected to the fluid network 1444 via a transport line 1461. As indicated by various arrows, fluid can flow from the reservoir 1411, through the wellbore 1406 and onto the fluid network 1444. Fluid can then flow from the fluid network 1444, for example, to one or more fluid processing facilities.

[00134] In the example of Fig. 14, sensors (S) are located, for example, to monitor various parameters during operations. The sensors (S) may measure, for example, pressure, temperature, flowrate, composition, and other parameters of the reservoir, wellbore, gathering network, process facilities and/or other portions of an operation. As an example, the sensors (S) may be operatively connected to a surface unit (e.g., to instruct the sensors to acquire data, to collect data from the sensors, etc.).

[00135] In the example of Fig. 14, a surface unit can include computer facilities, such as a memory device, a controller, one or more processors, and display unit (e.g., for managing data, visualizing results of an analysis, etc.). As an example, data may be collected in the memory device and processed by the processor(s) (e.g., for analysis, etc.). As an example, data may be collected from the sensors (S) and/or by one or more other sources. For example, data may be

supplemented by historical data collected from other operations, user inputs, etc. As an example, analyzed data may be used to in a decision making process.

[00136] As an example, a transceiver may be provided to allow communications between a surface unit and one or more pieces of equipment in the environment 1401. For example, a controller may be used to actuate mechanisms in the environment 1401 via the transceiver, optionally based on one or more decisions of a decision making process. In such a manner, equipment in the environment 1401 may be selectively adjusted based at least in part on collected data. Such adjustments may be made, for example, automatically based on computer protocol, manually by an operator or both. As an example, one or more well plans may be adjusted (e.g., to select optimum operating conditions, to avoid problems, etc.).

[00137] To facilitate data analyses, one or more simulators may be implemented (e.g., optionally via the surface unit or other unit, system, etc.). As an example, data fed into one or more simulators may be historical data, real time data or combinations thereof. As an example, simulation through one or more simulators may be repeated or adjusted based on the data received.

[00138] In the example of Fig. 14, simulators can include a reservoir simulator 1428, a wellbore simulator 1430, a surface network simulator 1432, a process simulator 1434 and an economics simulator 1436. As an example, the reservoir simulator 1428 may be configured to solve for hydrocarbon flow rate through a reservoir and into one or more wellbores. As an example, the wellbore simulator 1430 and surface network simulator 1432 may be configured to solve for hydrocarbon flow rate through a wellbore and a surface gathering network of pipelines. As to the process simulator 1434, it may be configured to model a processing plant where fluid containing hydrocarbons is separated into its constituent components (e.g., methane, ethane, propane, etc.), for example, and prepared for further distribution (e.g., transport via road, rail, pipe, etc.) and optionally sale. As an example, the economics simulator 1436 may be configured

to model costs associated with at least part of an operation. For example, consider MERAK™ framework (Schlumberger Limited, Houston, Texas), which may provide for economic analyses.

[00139] As an example, a system can include and/or be operatively coupled to one or more of the simulators 1428, 1430, 1432, 1434 and 1436 of Fig. 14. As an example, such simulators may be associated with frameworks and/or may be considered tools.

[00140] Fig. 15 shows a diagram that includes a planning phase 1520, which may correspond to the CAS 600 of Fig. 6 executing in an offline mode with respect to equipment at a site 1580 and that includes an operations phase 1540, which may correspond to the CAS 600 of Fig. 6 executing in an online mode with respect to equipment at the site 1580. The operations phase 1540 can be an operational mode of the CAS 600 that is an online mode with respect to equipment at one or more field sites.

[00141] The site 1580 includes equipment 1581 for injection of water to enhance recovery of oil where an injection well for water 1582, a production well for oil and water 1583 and a production well for “dry oil” 1584 (e.g., oil with a water fraction below a water fraction limit) are illustrated. The operations at the site 1580 can form a water cycle that includes injecting water such that water is transported through the field with flow in a reservoir leading to production followed by surface processing. Surface processing can include separating water from a mixture of water and oil where the water may be disposed of at the surface or injected for disposal or pressure maintenance (e.g., for maintaining reservoir pressure). In a field, production efficiency for oil can be managed through effective control of water, which may be achieved via water-control services. Factors involved in water control include flow rate, production rate, fluid properties (e.g., oil gravity and water salinity), and disposal method. Operational factors include those associated with, for example, lifting, separation, filtering, pumping and reinjection. Costs as to water control per barrel of oil can range

over a magnitude. Managing the cycle of water production (e.g., separation downhole or at surface, disposal, etc.) can involve a wide range of oilfield services, which can include data acquisition, diagnostics, production logging, water analysis, reservoir modeling (e.g., to characterize flow), and technologies to address water-related issues. A water-control plan can include setting-up equipment for detection of excess water and control of excess water once detected and/or once modeled to become an issue. During operations, one or more types of measurements may be made, optionally at different times, in response to different conditions (e.g., whether modeled and/or measured), etc. As an example, the CAS 600 can be implemented in one or more phases and/or one or more stages with respect to a field such as the field of the site 1580.

[00142] In the example of Fig. 15, a water cycle is illustrated via blocks 1592, 1594, 1596 and 1598. The block 1592 can represent one or more processes such as, for example, profile modification, water diversion, fluid monitoring, gel treatment(s), permeability modifier(s), and damage removal. The block 1594 can represent one or more processes such as, for example, water shutoff, scale and hydrate control and corrosion inhibition. The block 1596 can represent one or more processes such as processing of produced fluid, demulsification and/or corrosion-related fluid processing and facility debottlenecking. The block 1598 can represent one or more processes such as treating fluid, cleaning fluid and discharging fluid where such fluid can be or include water.

[00143] As an example, a representation of the site 1580 may be rendered to a display as part of a graphical user interface, which may be, for example, a rendered in part via a Web browser application executing on a client device with a network interface that is operatively coupled to the Internet and, for example, to a cloud environment. As an example, such a client device may be part of or operatively coupled to a client layer such as the client layer 510 of the architecture 500 of Fig. 5. As an example, such a client device may be operatively coupled to a system such as the CAS 600 of Fig. 6 via one or more networks.

[00144] Data associated with the site 1580 can include measured data and optionally synthetic data. For example, water flow may be modeled via a simulation model, which may be a dynamic simulation model that can receive information from a site during an injection operation and generate synthetic data in real-time or near real-time (e.g., of the order of minutes) that can be integrated into one or more analyses of a system such as the CAS 600.

[00145] A system such as the CAS 600 may utilize such data to identify a time-dependent response of injected water to production of oil and/or an oil and water mixture. As an example, an increase in water fraction in production of an oil and water mixture may indicate that streamlining is occurring at a point in time during a planned injection schedule, which may, for example, be dynamically adjusted according to output from a system such as the CAS 600. A system such as a CAS may include data and algorithm that are machine learning algorithms that are trained based on data from multiple injection scenarios at various sites, which may be, for example, sites for a common field. A CAS may analyze water fraction and/or one or more other measurements and respond to changes in by outputting parameters that can directly or indirectly be utilized to control equipment at a site during an ongoing operation or operations. For example, injection rate of water may be adjusted via control of one or more pumps.

[00146] Water control can increase well productivity and the amount of oil produced from a reservoir. A well can have a lifetime where, as the well matures, the water/oil ratio (WOR) increases with production due to increasing amounts of water being produced by the well. Various costs are associated with production and can be characterized in part by the WOR (e.g., or water fraction). For example, at a particular WOR, the cost of handling water can approach the value of oil being produced. In such an example, that particular WOR can be a proxy for an “economic limit” that is based on physical realities of handling water in a field during oil production. Water control can be implemented to reduce a well’s

water production (e.g., reducing the well's WOR), which can help to maintain WOR below an economic limit as the well matures. A reduction in WOR during a well's lifetime can provide an added recovery period of time for the well where the WOR again rises toward the WOR representing the economic limit; noting that such a WOR as an economic limit can change over time due to one or more factors (e.g., price of oil per barrel, cost of water, cost of handling water, etc.).

[00147] As an example, the CAS 600 may be implemented with respect to water in a multi-faceted manner. For example, the CAS 600 can operate in one state that acts to model and simulate flow of water and oil in a reservoir (see, e.g., the reservoir tool/framework of the tools component 640 as linked to the machine learning performance prediction algorithm) and can operate in another state that acts to optimize processing of multiphase fluid that includes oil and water (see, e.g., the optimization tool/framework of the tools component 640 as linked to the machine learning optimization algorithm). As an example, a state of the CAS 600 can be an overarching state that includes the aforementioned two states where they can be linked to generate multiple outputs per the output component 680. Such outputs can include field development plan output as to production of oil, an optimal treatment scenario output as to injection and handling of water, an immediate action notice or advice output as to a water-related parameter (e.g., produced fluid WOR or water fraction), and output as to adjustment of a reservoir model that is utilized to simulate fluid flow in the reservoir. Such a CAS can be operatively coupled to field equipment (e.g., sensors, controllers, etc.) and can be implemented at least in part via a cloud architecture such as the architecture 500 of Fig. 5. One or more components of such a CAS can be implemented in the applications layer 530 with compute resources (e.g., processors, memory, etc. of one or more servers). As mentioned, the CAS can be a continuous learning system. Thus, in the foregoing example as to states of operation of the CAS associated with water, the outputs can be directed to a database component (see, e.g., the database component 620) and utilized for training of one or more

machine learning algorithms (see, e.g., the algorithm component 630). As an example, such a database component can be implemented at least in part via the data layer 540 of the architecture 500 of Fig. 5.

[00148] As to inputs, in a water-related example, the input component 610 of the CAS 600 can be implemented at least in part via the client layer 510 of the architecture 500 of Fig. 5. For example, field equipment that can measure WOR (e.g., or water fraction), control injection of water, control treatment of water, control separation of water from a multiphase fluid that includes oil and water, etc., can include a client application that is operatively coupled to the integration layer 520 via one or more network interfaces. Such equipment may include a processor, memory, an operating system stored in the memory to establish an operating system environment in which applications can execute, and interfaces for transmission and/or receipt of information (e.g., measured data, control signals, etc.).

[00149] As an example, a plot of measured data received from field equipment may show water breakthrough in a production well at a time of about 3:30 am (e.g., a WOR or a water fraction in produced fluid being above a WOR or a water fraction level), which occurs at approximately 3 days into an injection operation in the field that utilizes injection equipment that can be controllable via receipt of control signals via an interface. In such an example, a first state can exist as to earlier times and a breakthrough state can exist as to later times. Such states can correspond to states of a system such as the CAS 600 of Fig. 6 where various features are activated and/or deactivated where, for example, a cloud platform may instantiate or de-instantiate various components as executable using cloud-based resources (see, e.g., the architecture 500 of Fig. 5). As an example, a state transition may be due to a change in WOR or water fraction, which can include breakthrough (e.g., where injected water flows through a reservoir to a production well and starts being produced alone or with oil). For example, the applications layer 530 of the architecture 500 may be reformulated based at least

in part on information received via the client layer 510 (e.g., field data via the input component 610) where compute resources are provisioned (e.g., processors, memory, etc.) to execute particular machine learning algorithms (e.g., of the algorithm component 630), to operatively couple to one or more tools (e.g., reservoir simulator, optimizer, etc.) and to generate output (e.g., per the output component 680). Thus, as an example, the CAS 600 can be a data-driven state machine that transitions from one state to another state automatically responsive to data that can be measured data as measured using equipment in a field.

[00150] In Fig. 15, the planning phase 1540 may correspond to the CAS 600 of Fig. 6 executing in an offline mode with respect to equipment at a site. In Fig. 15, the operations phase 1540 can correspond to the CAS 600 of Fig. 6 executing in an online mode with respect to equipment at the site (e.g., data flows to and from site equipment). As an example, a portion of the operations phase 1540 can utilize data acquired via equipment at the site 1580. As an example, the operations phase 1540 may act to trigger data acquisition and/or data transmission from equipment at the site 1580.

[00151] As an example, a planning phase may optionally be in an online mode that may be prior to execution of a water control plan such as a water injection plan that can enhance recovery of oil. One or more procedures may be performed where data acquired therefrom may be transmitted to a system such as the CAS 600 during a planning phase. As an example, a planning phase may generate information and/or requests for additional data acquisition from onsite equipment. For example, where a planning phase deems data insufficient to determine a plan or a portion of a plan, a system may generate a request (e.g., a control command, etc.) for additional data as may be acquired by onsite equipment. As an example, a planning phase may dynamically alter a system such as the CAS 600, optionally in a stage-by-stage manner, where output may include a system configuration for the CAS 600 to be implemented during an operational phase for one or more stages.

[00152] In the example of Fig. 15, the planning phase 1520 may optionally be implemented in an offline mode, in an online mode or in part in an offline mode and in part in an online mode. As an example, an online mode may be an online planning mode, which occurs prior to commencement of a plan. As an example, an online mode may be an online execution mode, which occurs during implementation of a plan.

[00153] In the example planning phase 1520, planning occurs for a four stage operation as output 1522, which is to be implemented during the operations phase 1540. As shown, stage 1 is performed using the CAS 600 in state “1”, stage 2 is performed using the system in state “2” and in state “3”, stage 3 is performed using the system in state “4” and in state “5” and stage 4 is performed using the system in state “6”. At the end of stage 4, the CAS 600 as in state “6” may proceed to transmit information and/or otherwise store information to one or more databases, generate one or more reports, performing machine learning, etc. As an example, the operations of the operations phase 1540 may be archived (see, e.g., the data layer 540 of Fig. 5).

[00154] In the example of Fig. 15, the state “5” can correspond to a state of the CAS 600 for the site 1580 where one or more water control parameters are to be adjusted. For example, the state “5” may output advice as to control of water injection equipment and/or other equipment associated with the water cycle (e.g., processing, etc.). In the example of Fig. 15, a transition from state “4” to state “5” may occur in response to measured data and/or synthetic data. For example, where measured data indicates an increase in WOR or water fraction being produced at a production well during a water injection operation, the CAS 600 may transition to a different state or, for example, where modeling of injected water in a formation indicates that a change in condition is likely to occur given a current water injection rate, the CAS 600 may transition from one state to another state. As mentioned, a state can be an advice state where control action may be taken based on advice communicated by the CAS 600. In turn, once the

control action is taken, the CAS 600 may transition to another state, for example, consider a transition to a reservoir modeling state that takes the control action into account (e.g., a reduction in water injection rate, a change to water injection in a different well, etc.). As another example, a state can provide information as to processing of fluid produced at a production well or production wells.

[00155] As explained with respect to the examples of Fig. 15, the CAS 600 can operate dynamically and change state based on one or more of planned stages, measured data (e.g., real-time data, etc.) and synthetic data (e.g., via reservoir simulation, etc.). As explained, the CAS 600 can include one or more feedback loops such that learning can be continuous as the CAS 600 transitions from one phase to another phase and/or as the CAS 600 transitions from one state to another state.

[00156] As an example, a CAS can be a system that can plan and control a job for a selected well drilled through a specific formation based on the experience on multiple jobs at various wells having similar properties. Such a system can include components to generate prompt advice as to adjustments that can be made, automatically and/or manually, during a job (e.g., to avoid an operational failure, to optimize one or more parameters, etc.). A system can include one or more components that can check for the consistency of input, acquired and generated data, for example, to reduce risk of misleading predictions. As an example, a system can include various tools which can be used independently (prompt performance predictor, advisor, optimizer, adjuster, etc.). As an example, a system can be continuously updated with new live and physical modeling data. In such an example, the system can accumulate new knowledge (e.g., machine learning expertise) and may automatically refine prediction models.

[00157] As shown in the examples of Figs. 6 to 15, a system may be associated with workflows. For example, the CAS 600 can be dynamically configured to perform various workflows. As an example, one or more portions

of the CAS 600 may be instantiated in a cloud environment and available to a plurality of sites, whether in online or offline modes.

[00158] As mentioned, a system can be scalable, which may range in scale from a local implementation to a cloud implementation that is operatively coupled to local equipment at a field site. As an example, a system may be implemented at least in part on a local server or workstation utilizing the data from boreholes of a particular configuration (e.g., borehole configurations that can be a set of wellbore and near-wellbore characteristics relevant to a job). As an example, a system may be run for a reservoir that includes a plurality of wells, for production and/or injection. In such an example, the reservoir can have an associated common smart database and frameworks but different machine learning and prediction blocks for boreholes (e.g., wells) of each configurations present within the reservoir.

[00159] As an example, a framework may be run at least in part on a local server or, for example, a workstation utilizing information associated with a particular reservoir. For example, a workstation may be at a wellsite (e.g., in a driller cabin, etc.) and/or at another location that can receive information for the particular reservoir (e.g., one or more wells that can acquire data, inject fluid and/or produce fluid).

[00160] As an example, a framework may be implemented at least in part in a cloud environment. For example, consider the AZURE® cloud platform (Microsoft Corporation, Redmond, Washington). As an example, a framework may be accessible via a network connection to a cloud platform, for example, via a mobile device, which may include, for example, one or more mobile apps that may provide for operatively coupling cloud resources and mobile device resources. As an example, a mobile app may include features that can allow for delivery of information such as, for example, one or more immediate action advice notices, one or more alerts, data monitoring (e.g., for new data inflows,

etc.), corresponding changes in one or more strategic plans, for example, within an optimal treatment scenario, etc.

[00161] As an example, a CAS may operate at several reservoirs, optionally simultaneously. As an example, a system may include and/or access a common smart database (e.g., to retrieve and/or to store information). As an example, a CAS may be operated in one manner as to learning and may be operated in another manner as to prediction. For example, a CAS may be trained prior to use for a particular reservoir as to predictions for the reservoir. As an example, a CAS may be operatively coupled to one or more frameworks, which may be accessible via one or more networks (e.g., consider one or more local and/or one or more remote frameworks). As an example, a CAS and one or more frameworks (e.g., tools, etc.) may be installed on a common computing device or common computing system. As an example, a framework may be implemented and/or instantiated on one or more machines (e.g., one or more computers, servers, mobile devices, controllers, etc.). As an example, a framework may be implemented on a reservoir by reservoir basis where information as to learning, etc. may be accessible to the implemented frameworks, for example, via a server or servers that may maintain data, etc. for the frameworks.

[00162] As an example, a cognitive advisory system (CAS) can provide for prediction, optimization, and control of reservoir performance (see, e.g., the examples of Figs. 7 to 14 and the water control examples described with respect to Fig. 15). Such a CAS can utilize one or both of simulation data and real field data and can be a self-learning computer system that can run in various modes that include an online machine learning mode (e.g., a slow background mode) and an operational mode (e.g., a fast optimization/prediction/control mode). As an example, a CAS can operate to continuously improve its “expertize” (e.g., in the machine learning mode) and, thereby, improve accuracy of its operational mode. As an example, a CAS can operate continuously to renew a database by accounting for various impacts on a reservoir linked with applications of different

technologies on reservoir wells (e.g., fracturing, well intervention, artificial lift systems deployment, intelligent completions deployment, etc.). A CAS may receive and store information relevant to an oilfield as to factors such as, for example, market, economics, local specific knowledge, climate, etc.

[00163] As an example, a CAS can allow for generation of both short and long term recommendations on production optimization based on both comparative analysis of reservoir development scenarios and immediate smart data mining within historical reservoir performance. As an example, a CAS can generate control actions, which may, for example, aim to prevent hazardous situations, mitigate risks and to provide planned production volume and rates.

[00164] A method can include receiving information associated with a reservoir in a geologic environment; predicting one or more conditions based at least in part on the information; and outputting information based at least in part on at least one of the one or more predicted conditions. In such an example, predicting can be based at least in part on implementation of at least one machine learning algorithm (e.g., one or more trained machine learning algorithm).

[00165] As an example, a method can include implementing at least one machine learning algorithm. As an example, a method can include receiving information analyzed by a data analyzer where, for example, the method may include receiving at least a portion of output information by the data analyzer, analyzing the at least a portion of the output information to generate analyzed information, and storing at least a portion of the analyzed information. In such an example, a feedback loop may be established that may provide for further learning (e.g., training one or more machine learning algorithms, etc.).

[00166] As an example, a method can include outputting information associated with a field development plan. As an example, a method can include predicting one or more conditions that include at least one predicted fluid production condition, which may be, for example, a basis for output information.

As an example, a method can include implementing a portion of a field development plan.

[00167] As an example, a method can include outputting information associated with a treatment (e.g., a stimulation treatment, etc.). As an example, a method can include predicting one or more conditions that include at least one predicted treatment condition, which may be, for example, a basis for output information. As an example, a method can include performing a treatment.

[00168] As an example, a method can include outputting information associated with an advised action. As an example, a method can include predicting one or more conditions that include at least one control condition, which may be, for example, a basis for output information. As an example, a method can include controlling one or more operations.

[00169] As an example, a method can include outputting information associated with a reservoir model of the reservoir. As an example, a method can include predicting one or more conditions that include at least one adjusted reservoir model condition, which may be, for example, a basis for output information. As an example, a method can include performing one or more simulations using an adjusted model (e.g., consider a reservoir simulation using an adjusted reservoir model).

[00170] A system can include a processor; memory accessibly by the processor; and processor-executable instructions stored in the memory and executable to instruct the system to receive information associated with a reservoir in a geologic environment; predict one or more conditions based at least in part on the information; and output information based at least in part on at least one of the one or more predicted conditions. As an example, such a system can include a database and/or a data analyzer. For example, a data analyzer may analyze received information and determine types and/or forms of information to be stored in a database. As an example, such a database may be a smart database. As an example, a system may output information and receive information based

at least in part on such output where, for example, a data analyzer may analyze the received information and store analyzed information in a database. As an example, such a database can include information germane to one or more algorithms, which may include one or more machine learning algorithms, one or more prediction algorithms, etc. As an example, a system can include one or more network interfaces, which may be operatively coupled to one or more networks (e.g., cellular, satellite, cable, etc.).

[00171] One or more computer-readable storage media can include computer-executable instructions where the computer-executable instructions include instructions to instruct a computer to: receive information associated with at least one reservoir in at least one geologic environment; and train one or more algorithms based at least in part on the information. In such an example, instructions can be included to receive information associated with one or more predictions based at least in part on the one or more trained algorithms. As an example, instructions can be included to further train at least one of the one or more algorithms based at least in part on the information associated with the one or more predictions.

[00172] One or more computer-readable storage media can include computer-executable instructions where the computer-executable instructions include instructions to instruct a computer to: receive information associated with a reservoir in a geologic environment; predict one or more conditions based at least in part on the information; and output information based at least in part on at least one of the one or more predicted conditions.

[00173] As an example, a system can include an input component that includes at least one network interface that receives data where the data includes data acquired by one or more pieces of field equipment during an operation at a field site and a reservoir model; a database component that includes a database and a data analyzer operatively coupled to the network interface for receipt of the data; a machine learning component operatively coupled to the database

component and operatively coupled to a reservoir simulation framework that utilizes the reservoir model where the machine learning component includes a machine learning mode that generates at least one trained machine learning algorithm and an operational mode that generates results based at least in part on at least one trained machine learning algorithm; and an output component operatively coupled to the database component where the output component outputs information based at least in part on the results of the operational mode of the machine learning component. In such an example, the machine learning mode and the operational mode can operate simultaneously during receipt of data by the input component where the data includes data acquired by one or more pieces of field equipment during an operation at a field site. In such an example, output generated by the system may be received by the database component and, for example, utilized in training a machine learning algorithm and/or one or more other processes, which may include, for example, adjusting the reservoir model, which may be stored as a digital model in the database.

[00174] As an example, output information can include a field development plan for production of hydrocarbons via one or more pieces of field equipment at the field site. As an example, output information can include an optimal treatment scenario for production of hydrocarbons via the one or more pieces of field equipment at the field site. As an example, a treatment scenario can be an enhanced oil recovery (EOR) scenario, which may include, for example, injection of water into a reservoir. As an example, output information can include a control action for control of the one or more pieces of field equipment at the field site. As an example, output information can include an adjusted reservoir model for utilization by a reservoir simulation framework. As mentioned, a reservoir model may be a digital model that can be stored in a database that can be accessible, directly or indirectly, by a reservoir simulation framework.

[00175] As an example, a machine learning component can include an inversion algorithm that inverts data received from a database component to

adjust a reservoir model. For example, field data can be received by an input component and stored to a database of the database component. Such field data may be utilized in an inversion process that aims to reconstruct subterranean, spatial properties of a reservoir. Such spatial properties can include properties utilized in simulation fluid flow in the reservoir by a reservoir simulation framework. Such spatial properties can be assigned to a reservoir model such that the reservoir simulation framework simulates fluid flow based at least in part on such spatial properties.

[00176] As an example, a machine learning component can include an optimization algorithm that optimizes a treatment scenario. As an example, a treatment scenario may be an EOR treatment scenario. As an example, a treatment scenario may be a processing scenario that treats produced fluid, which can be, for example, multiphase fluid that includes oil and water.

[00177] As an example, a system can include a state transition component that transitions operational mode states based at least in part on data acquired by one or more pieces of field equipment during an operation at a field site. For example, a state transition component can be an algorithm that compares received data, whether raw and/or analyzed, to one or more limits. As to water related operations, for example, where a WOR or a water fraction exceeds a limit (e.g., an economic limit or other type of limit), an algorithm of a state transition component may trigger provisioning of compute resources and instantiate one or more machine learning algorithms that transition the system from one state of the system to a different state of the system. As an example, a state transition component that transitions operational mode states may transition states based at least in part on simulation results generated by a reservoir simulation framework that utilizes a reservoir model. For example, simulation results may indicate that breakthrough of injected water may occur within a period of time at one or more production wells and, to reduce WOR or water fraction at the one or more production wells, the transition may be to a state of the system that can optimize

one or more water-related processes and, for example, generate output that can control equipment associated with such one or more water-related processes in the field.

[00178] As an example, an operational mode of a system can include one or more of a water injection operational state, an artificial lift operational state, a real-time control operational state, and a reservoir model adjustment operational state.

[00179] As an example, a method can include receiving, via a network interface, data acquired by one or more pieces of field equipment during an operation at a field site; accessing a database to retrieve information associated with the field site; based at least in part on the data and the information, generating a trained machine learning algorithm; executing, based at least in part on the data and the information, the trained machine learning algorithm using one or more processors to generate a result; and based at least in part on the result, predicting an outcome for the operation at the field site and transmitting the outcome to the database. In such an example, the method can include receiving, via the network interface, additional data and regenerating the trained machine learning algorithm based at least in part on the outcome and at least a portion of the additional data.

[00180] As an example, an operation can be a treatment operation. As an example, an outcome can include a control action for control of an operation at a field site. In such an example, the method can include communicating the control action to the field site.

[00181] One or more computer-readable storage media can include computer-executable instructions where the computer-executable instructions include instructions to instruct a computing system to: receive, via a network interface, data acquired by one or more pieces of field equipment during an operation at a field site; access a database to retrieve information associated with the field site; based at least in part on the data and the information, generate a trained machine learning algorithm; execute, based at least in part on the data and

the information, the trained machine learning algorithm using one or more processors to generate a result; and, based at least in part on the result, predict an outcome for the operation at the field site and transmitting the outcome to the database.

[00182] In some embodiments, a method or methods may be executed by a computing system. Fig. 16 shows an example of a system 1600 that can include one or more computing systems 1601-1, 1601-2, 1601-3 and 1601-4, which may be operatively coupled via one or more networks 1609, which may include wired and/or wireless networks.

[00183] As an example, a system can include an individual computer system or an arrangement of distributed computer systems. In the example of Fig. 16, the computer system 1601-1 can include one or more modules 1602, which may be or include processor-executable instructions, for example, executable to perform various tasks (e.g., receiving information, requesting information, processing information, simulation, outputting information, etc.).

[00184] As an example, a module may be executed independently, or in coordination with, one or more processors 1604, which is (or are) operatively coupled to one or more storage media 1606 (e.g., via wire, wirelessly, etc.). As an example, one or more of the one or more processors 1604 can be operatively coupled to at least one of one or more network interface 1607. In such an example, the computer system 1601-1 can transmit and/or receive information, for example, via the one or more networks 1609 (e.g., consider one or more of the Internet, a private network, a cellular network, a satellite network, etc.).

[00185] As an example, the computer system 1601-1 may receive from and/or transmit information to one or more other devices, which may be or include, for example, one or more of the computer systems 1601-2, etc. A device may be located in a physical location that differs from that of the computer system 1601-1. As an example, a location may be, for example, a processing facility

location, a data center location (e.g., server farm, etc.), a rig location, a wellsite location, a downhole location, etc.

[00186] As an example, a processor may be or include a microprocessor, microcontroller, processor module or subsystem, programmable integrated circuit, programmable gate array, or another control or computing device.

[00187] As an example, the storage media 1606 may be implemented as one or more computer-readable or machine-readable storage media. As an example, storage may be distributed within and/or across multiple internal and/or external enclosures of a computing system and/or additional computing systems.

[00188] As an example, a storage medium or storage media may include one or more different forms of memory including semiconductor memory devices such as dynamic or static random access memories (DRAMs or SRAMs), erasable and programmable read-only memories (EPROMs), electrically erasable and programmable read-only memories (EEPROMs) and flash memories, magnetic disks such as fixed, floppy and removable disks, other magnetic media including tape, optical media such as compact disks (CDs) or digital video disks (DVDs), BLUERAY® disks, or other types of optical storage, or other types of storage devices.

[00189] As an example, a storage medium or media may be located in a machine running machine-readable instructions, or located at a remote site from which machine-readable instructions may be downloaded over a network for execution.

[00190] As an example, various components of a system such as, for example, a computer system, may be implemented in hardware, software, or a combination of both hardware and software (e.g., including firmware), including one or more signal processing and/or application specific integrated circuits.

[00191] As an example, a system may include a processing apparatus that may be or include a general purpose processors or application specific chips (e.g., or chipsets), such as ASICs, FPGAs, PLDs, or other appropriate devices.

[00192] Fig. 17 shows components of an example of a computing system 1700 and an example of a networked system 1710. The system 1700 includes one or more processors 1702, memory and/or storage components 1704, one or more input and/or output devices 1706 and a bus 1708. In an example embodiment, instructions may be stored in one or more computer-readable media (e.g., memory/storage components 1704). Such instructions may be read by one or more processors (e.g., the processor(s) 1702) via a communication bus (e.g., the bus 1708), which may be wired or wireless. The one or more processors may execute such instructions to implement (wholly or in part) one or more attributes (e.g., as part of a method). A user may view output from and interact with a process via an I/O device (e.g., the device 1706). In an example embodiment, a computer-readable medium may be a storage component such as a physical memory storage device, for example, a chip, a chip on a package, a memory card, etc. (e.g., a computer-readable storage medium).

[00193] In an example embodiment, components may be distributed, such as in the network system 1710. The network system 1710 includes components 1722-1, 1722-2, 1722-3, . . . 1722-N. For example, the components 1722-1 may include the processor(s) 1702 while the component(s) 1722-3 may include memory accessible by the processor(s) 1702. Further, the component(s) 1722-2 may include an I/O device for display and optionally interaction with a method. The network may be or include the Internet, an intranet, a cellular network, a satellite network, etc.

[00194] As an example, a device may be a mobile device that includes one or more network interfaces for communication of information. For example, a mobile device may include a wireless network interface (e.g., operable via IEEE 802.11, ETSI GSM, BLUETOOTH™, satellite, etc.). As an example, a mobile device may include components such as a main processor, memory, a display, display graphics circuitry (e.g., optionally including touch and gesture circuitry), a SIM slot, audio/video circuitry, motion processing circuitry (e.g.,

accelerometer, gyroscope), wireless LAN circuitry, smart card circuitry, transmitter circuitry, GPS circuitry, and a battery. As an example, a mobile device may be configured as a cell phone, a tablet, etc. As an example, a method may be implemented (e.g., wholly or in part) using a mobile device. As an example, a system may include one or more mobile devices.

[00195] As an example, a system may be a distributed environment, for example, a so-called “cloud” environment where various devices, components, etc. interact for purposes of data storage, communications, computing, etc. As an example, a device or a system may include one or more components for communication of information via one or more of the Internet (e.g., where communication occurs via one or more Internet protocols), a cellular network, a satellite network, etc. As an example, a method may be implemented in a distributed environment (e.g., wholly or in part as a cloud-based service).

[00196] As an example, information may be input from a display (e.g., consider a touchscreen), output to a display or both. As an example, information may be output to a projector, a laser device, a printer, etc. such that the information may be viewed. As an example, information may be output stereographically or holographically. As to a printer, consider a 2D or a 3D printer. As an example, a 3D printer may include one or more substances that can be output to construct a 3D object. For example, data may be provided to a 3D printer to construct a 3D representation of a subterranean formation. As an example, layers may be constructed in 3D (e.g., horizons, etc.), geobodies constructed in 3D, etc. As an example, holes, fractures, etc., may be constructed in 3D (e.g., as positive structures, as negative structures, etc.).

[00197] Although only a few example embodiments have been described in detail above, those skilled in the art will readily appreciate that many modifications are possible in the example embodiments. Accordingly, all such modifications are intended to be included within the scope of this disclosure as defined in the following claims. In the claims, means-plus-function clauses are

intended to cover the structures described herein as performing the recited function and not only structural equivalents, but also equivalent structures. Thus, although a nail and a screw may not be structural equivalents in that a nail employs a cylindrical surface to secure wooden parts together, whereas a screw employs a helical surface, in the environment of fastening wooden parts, a nail and a screw may be equivalent structures. It is the express intention of the applicant not to invoke 35 U.S.C. § 112, paragraph 6 for any limitations of any of the claims herein, except for those in which the claim expressly uses the words “means for” together with an associated function.

Bibliography (documents that are incorporated by reference herein)

1. Shahab D. Mohaghegh et al., Coupling Numerical Simulation and Machine Learning to Model Shale Gas Production at Different Time Resolutions. *Journal of Natural Gas Science and Engineering*, Vol. 25 (2015) - pp 380-392.
2. Shapiro, Ehud Y. Inductive inference of theories from facts, Research Report 192, Yale University, Department of Computer Science, 1981. Reprinted in J.-L. Lassez, G. Plotkin (Eds.), *Computational Logic*, The MIT Press, Cambridge, MA, 1991, pp. 199–254.
3. Agrawal, R.; Imieliński, T.; Swami, A. (1993). "Mining association rules between sets of items in large databases". *Proceedings of the 1993 ACM SIGMOD international conference on Management of data - SIGMOD '93*. p. 207.
4. Danial Kaviani, Mohammad Soroush, Jerry L. Jensen, How accurate are Capacitance Model connectivity estimates?, *Journal of Petroleum Science and Engineering*, Volume 122, October 2014, Pages 439–452
5. Emre Artun, Characterizing interwell connectivity in waterflooded reservoirs using data-driven and reduced-physics models: a comparative study, *Neural Computing and Applications*, pp. 1-15, First online: 08 January 2016

6. Deng, L.; Yu, D. (2014) "Deep Learning: Methods and Applications" (PDF). Foundations and Trends in Signal Processing 7: 3–4
7. Mehryar Mohri, Afshin Rostamizadeh, Ameet Talwalkar (2012) Foundations of Machine Learning, The MIT Press ISBN 9780262018258.
8. Rokach, Lior; Maimon, O. (2008). Data mining with decision trees: theory and applications. World Scientific Pub Co Inc. ISBN 978-9812771711.
9. Shai Shalev-Shwartz (2012), "Online Learning and Online Convex Optimization", Foundations and Trends® in Machine Learning: Vol. 4: No. 2, pp 107-194. <http://dx.doi.org/10.1561/22000000018>
10. Tarantola, A; (2005) Inverse Problem Theory, SIAM.

CLAIMS

What is claimed is:

1. A system comprising:

an input component that comprises at least one network interface that receives data wherein the data comprises data acquired by one or more pieces of field equipment during an operation at a field site and a reservoir model;

a database component that comprises a database and a data analyzer operative coupled to the network interface for receipt of the data;

a machine learning component operatively coupled to the database component and operatively coupled to a reservoir simulation framework that utilizes the reservoir model wherein the machine learning component comprises a machine learning mode that generates at least one trained machine learning algorithm and an operational mode that generates results based at least in part on at least one trained machine learning algorithm; and

an output component operatively coupled to the database component wherein the output component outputs information based at least in part on the results of the operational mode of the machine learning component.

2. The system of claim 1 wherein the machine learning mode and the operational mode operate simultaneously during receipt of data by the input component wherein the data comprises data acquired by one or more pieces of field equipment during an operation at a field site.

3. The system of claim 1 wherein the output information comprises a field development plan for production of hydrocarbons via the one or more pieces of field equipment at the field site.

4. The system of claim 1 wherein the output information comprises an optimal treatment scenario for production of hydrocarbons via the one or more pieces of field equipment at the field site.
5. The system of claim 1 wherein the output information comprises a control action for control of the one or more pieces of field equipment at the field site.
6. The system of claim 1 wherein the output information comprises an adjusted reservoir model for utilization by the reservoir simulation framework.
7. The system of claim 1 wherein the machine learning component comprises an inversion algorithm that inverts data received from the database component to adjust the reservoir model.
8. The system of claim 1 wherein the machine learning component comprises an optimization algorithm that optimizes a treatment scenario.
9. The system of claim 1 comprising a state transition component that transitions operational mode states based at least in part on data acquired by one or more pieces of field equipment during an operation at a field site.
10. The system of claim 1 comprising a state transition component that transitions operational mode states based at least in part on simulation results generated by the reservoir simulation framework that utilizes the reservoir model.
11. The system of claim 1 wherein the operational mode comprises a water injection operational state.

12. The system of claim 1 wherein the operational mode comprises an artificial lift operational state.
13. The system of claim 1 wherein the operational mode comprises a real-time control operational state.
14. The system of claim 1 wherein the operational mode comprises a reservoir model adjustment operational state.
15. A method comprising:
 - receiving, via a network interface, data acquired by one or more pieces of field equipment during an operation at a field site;
 - accessing a database to retrieve information associated with the field site;
 - based at least in part on the data and the information, generating a trained machine learning algorithm;
 - executing, based at least in part on the data and the information, the trained machine learning algorithm using one or more processors to generate a result; and
 - based at least in part on the result, predicting an outcome for the operation at the field site and transmitting the outcome to the database.
16. The method of claim 15 comprising receiving, via the network interface, additional data and regenerating the trained machine learning algorithm based at least in part on the outcome and at least a portion of the additional data.
17. The method of claim 15 wherein the operation comprises a treatment operation.
18. The method of claim 15 wherein the outcome comprises a control action for control of the operation at the field site.

19. The method of claim 18 comprising communicating the control action to the field site.

20. One or more computer-readable storage media comprising computer-executable instructions wherein the computer-executable instructions comprise instructions to instruct a computing system to:

receive, via a network interface, data acquired by one or more pieces of field equipment during an operation at a field site;

access a database to retrieve information associated with the field site;

based at least in part on the data and the information, generate a trained machine learning algorithm;

execute, based at least in part on the data and the information, the trained machine learning algorithm using one or more processors to generate a result; and

based at least in part on the result, predict an outcome for the operation at the field site and transmitting the outcome to the database.

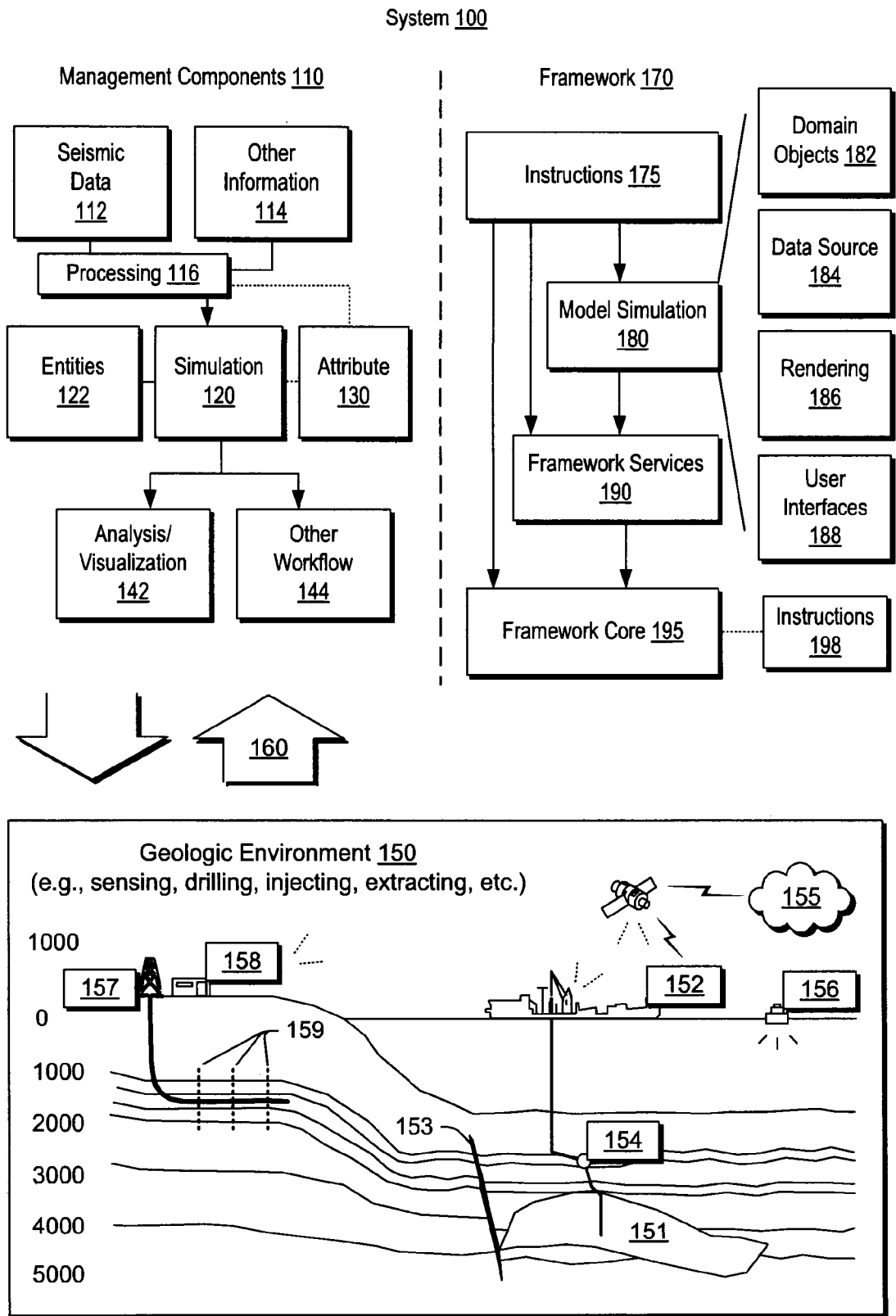

Fig. 1

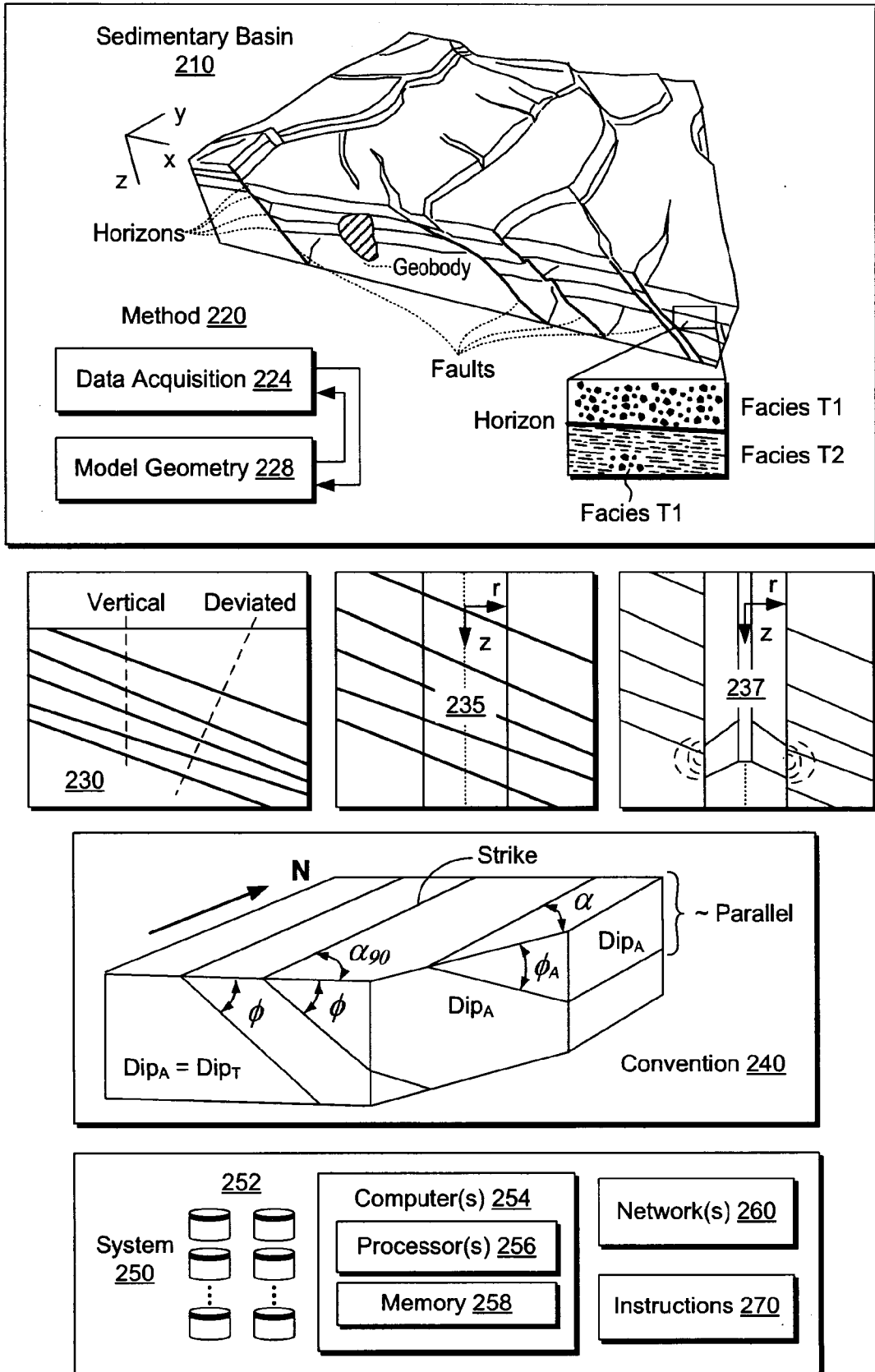

Fig. 2

Method 300

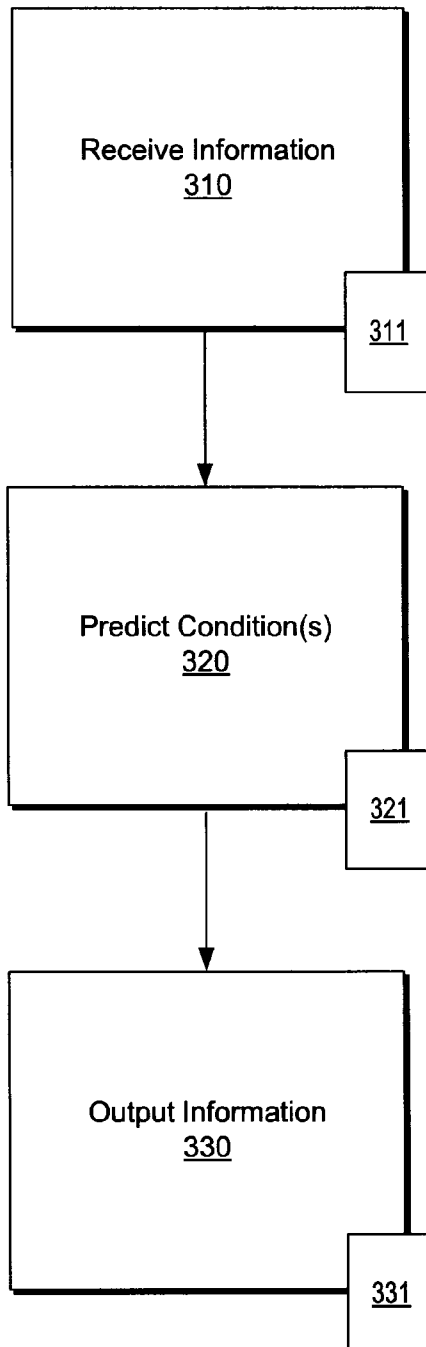

Fig. 3

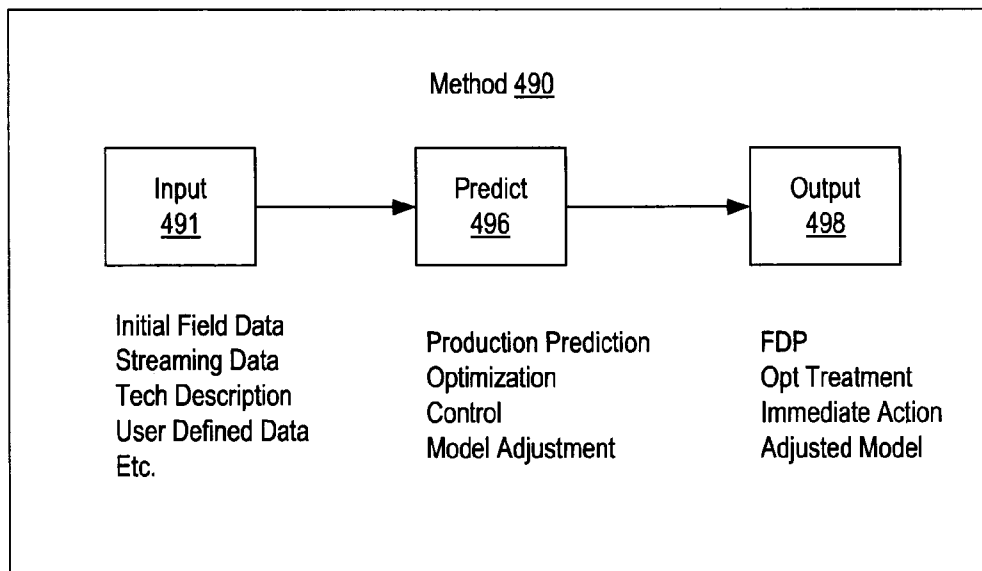
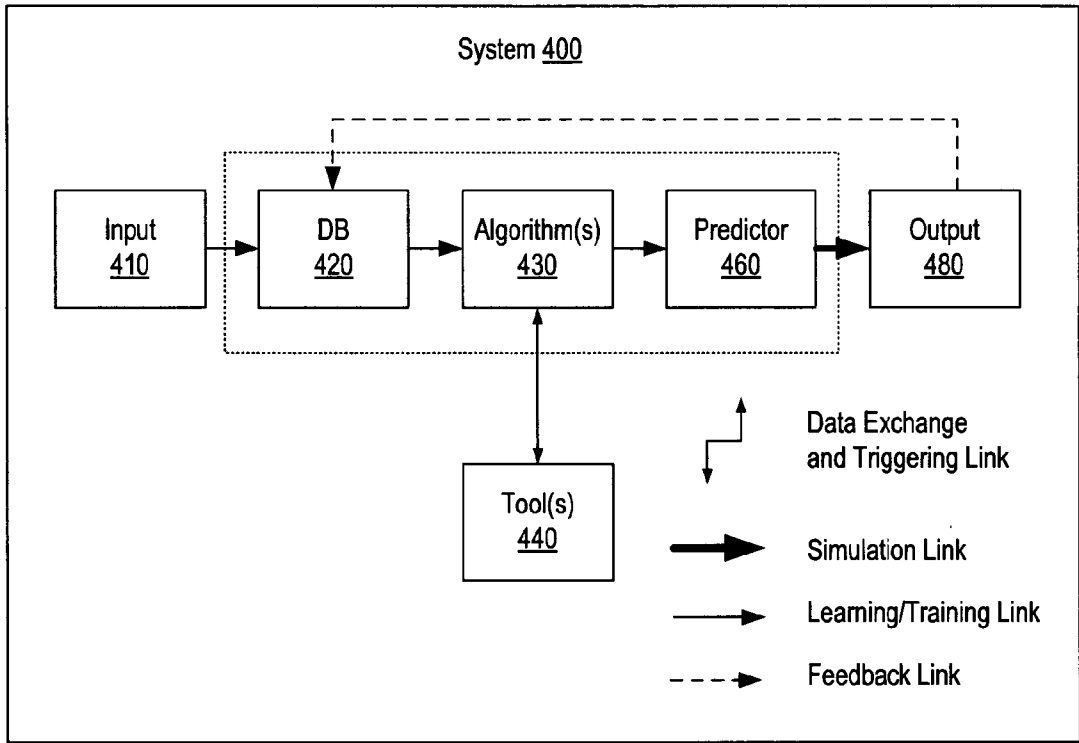

Fig. 4

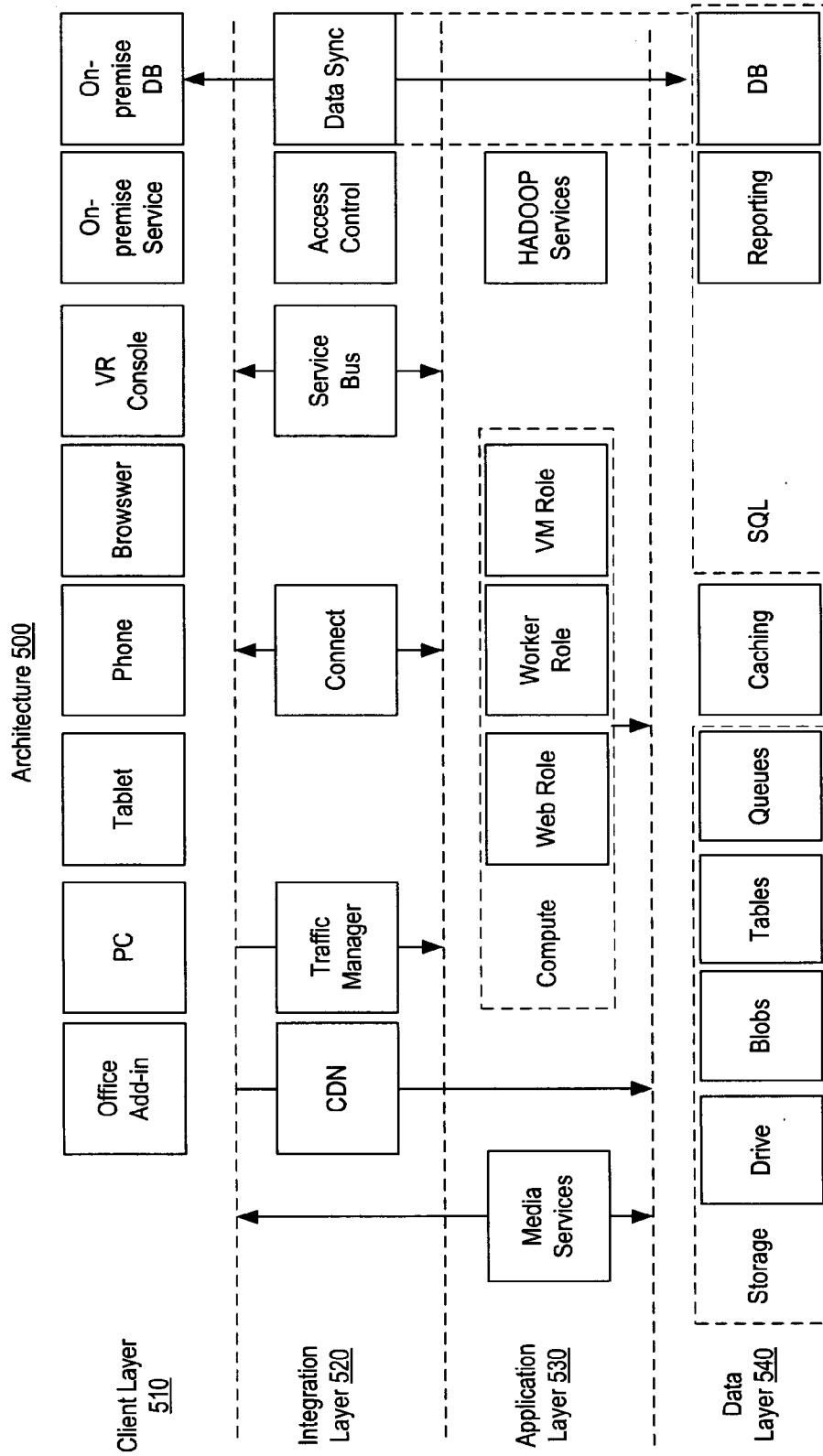

Fig. 5

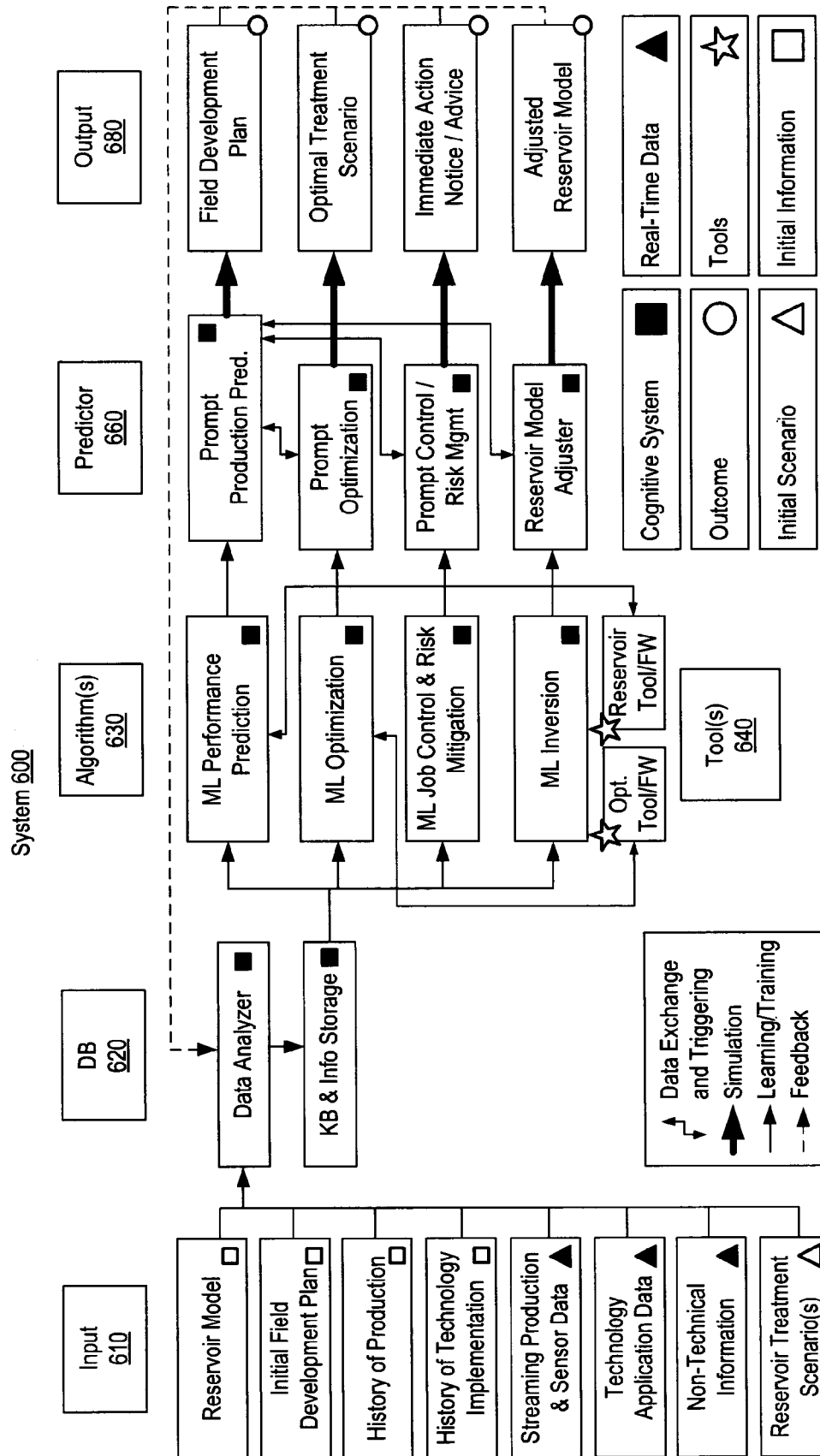

Fig. 6

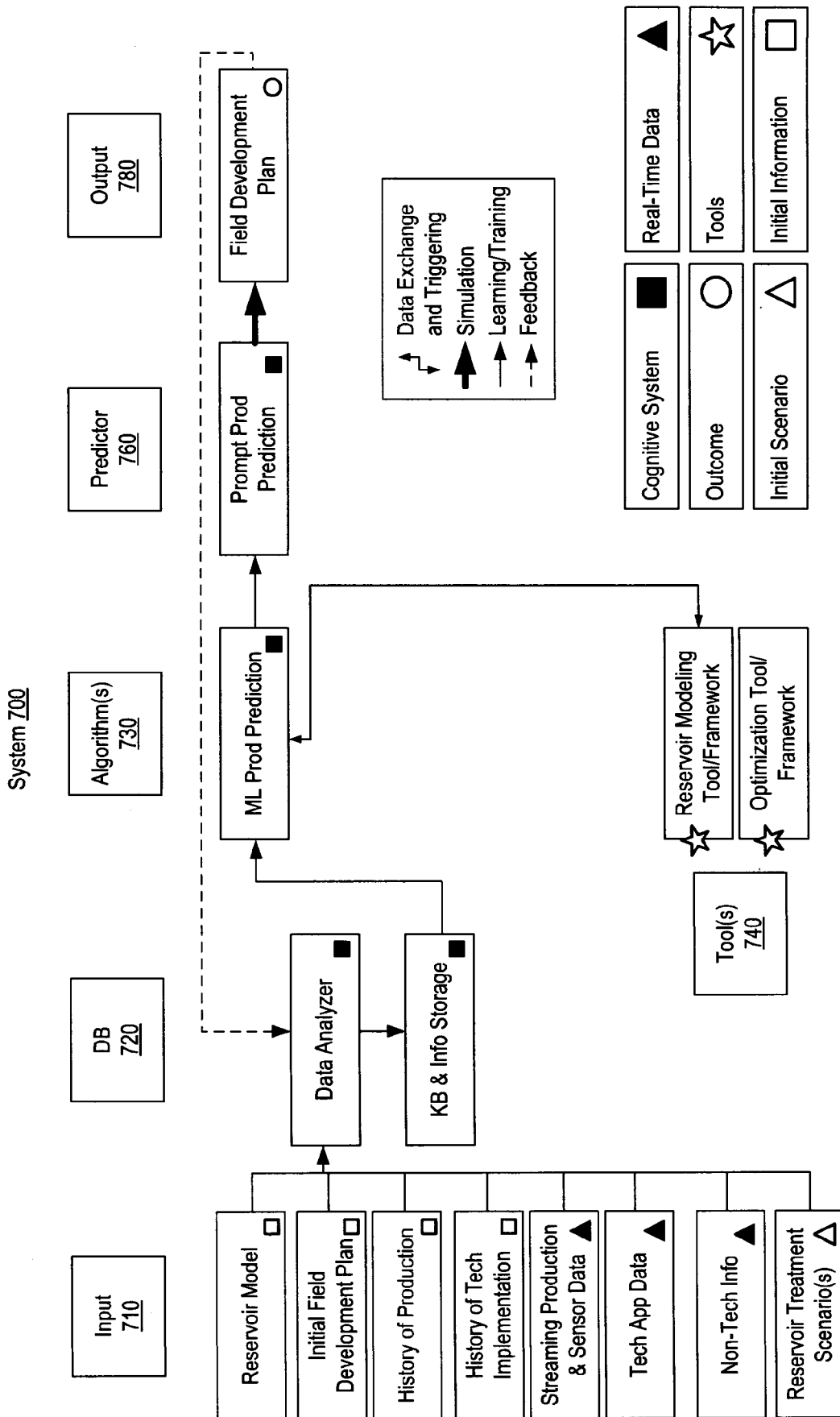

Fig. 7

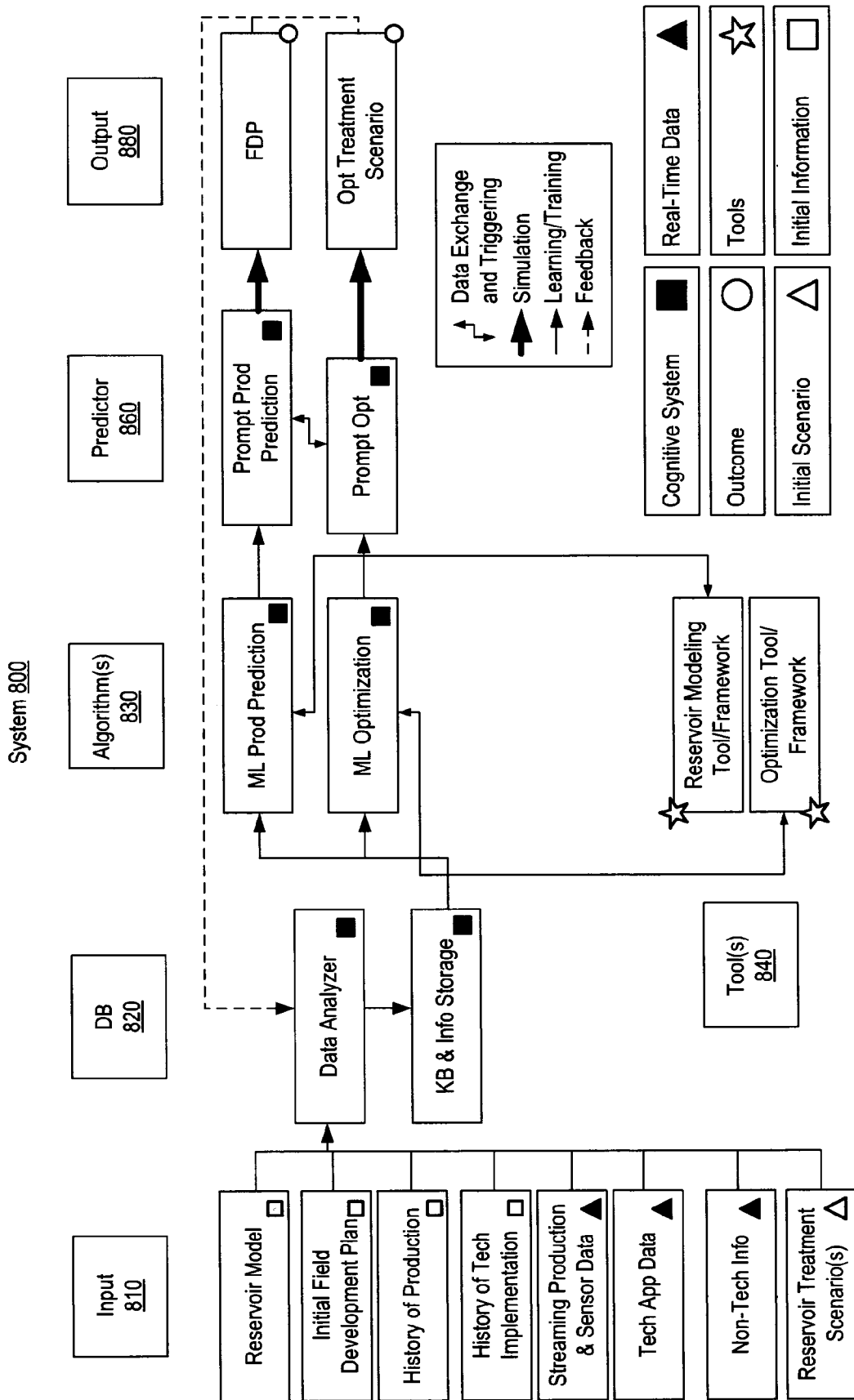

Fig. 8

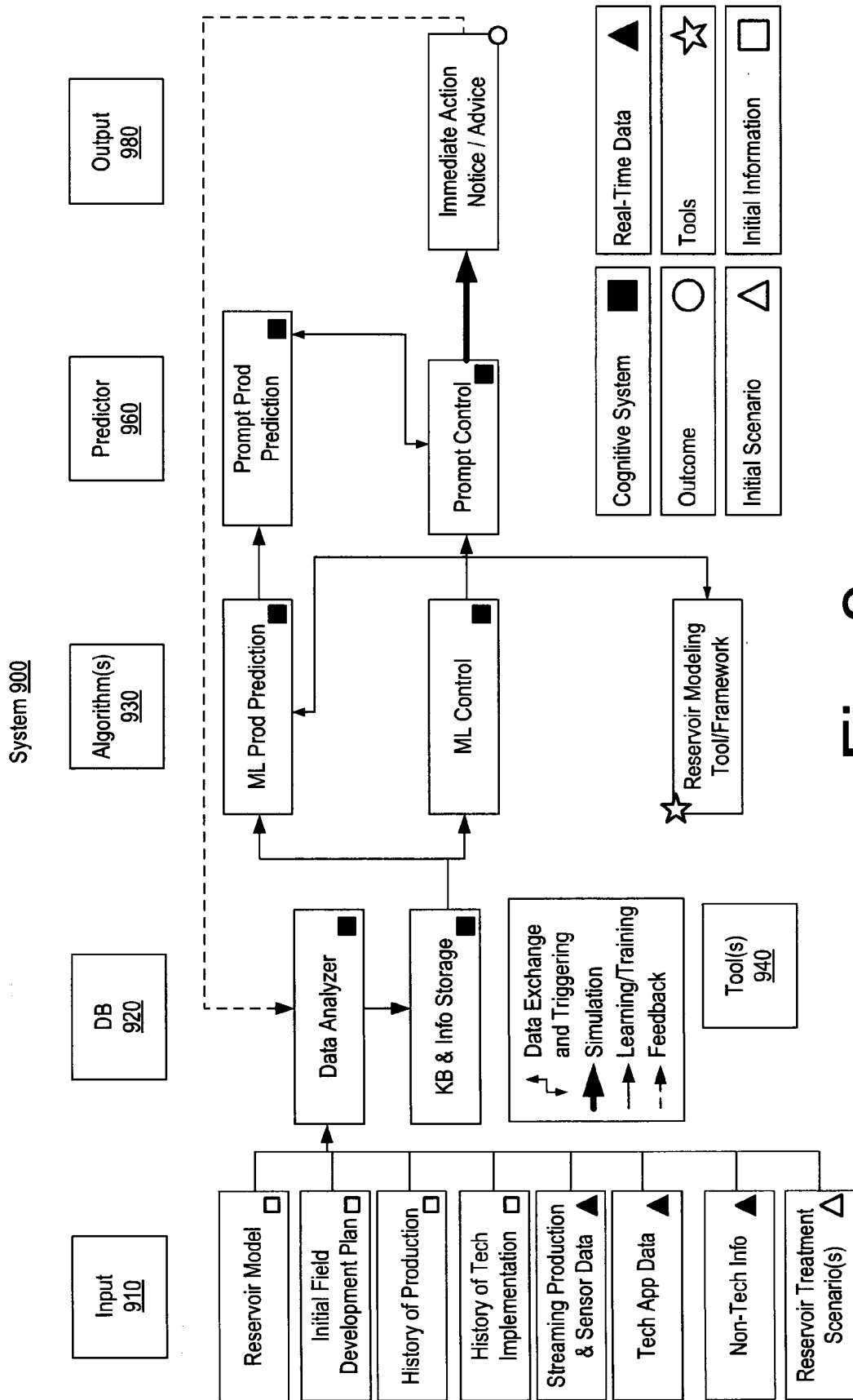

Fig. 9

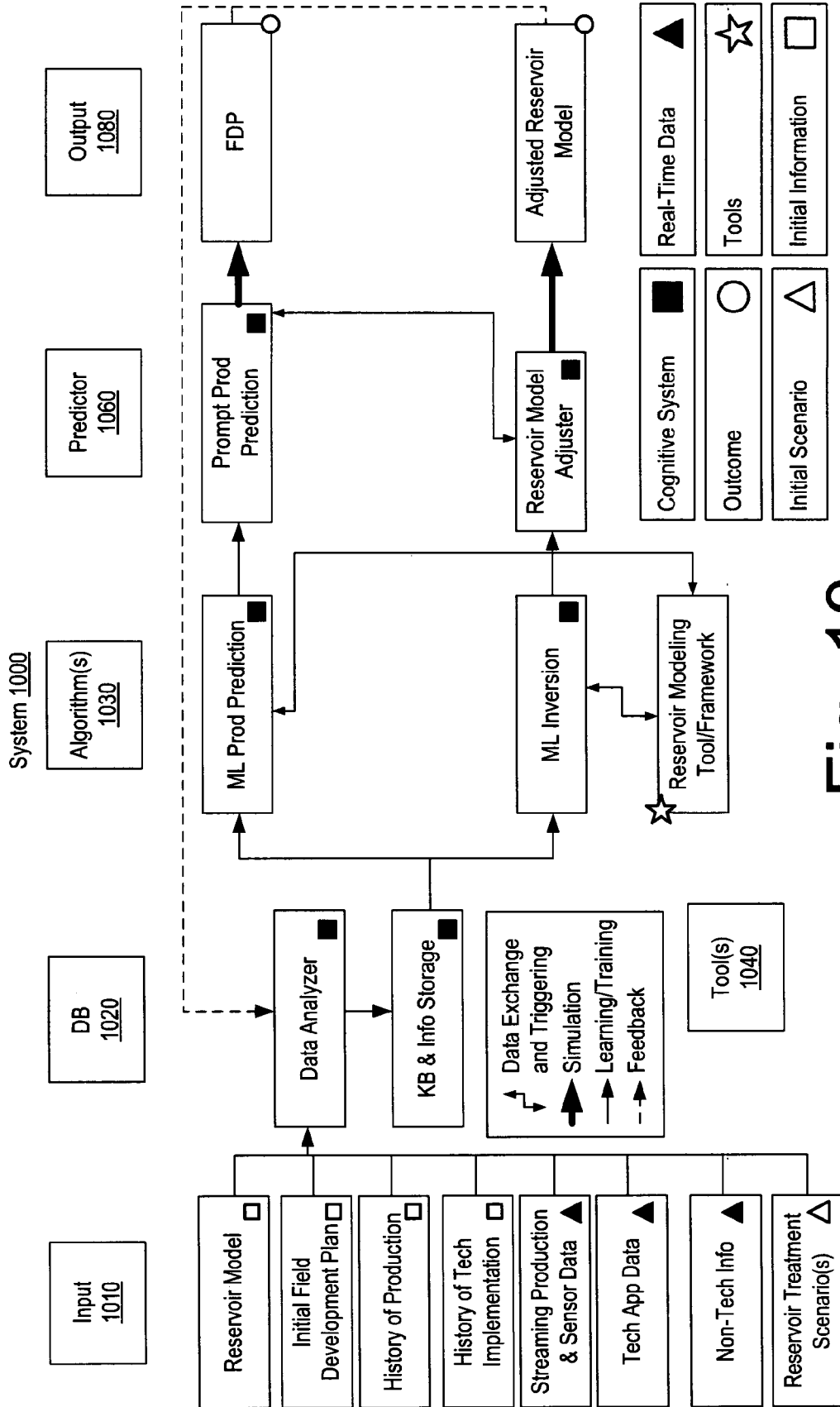

Fig. 10

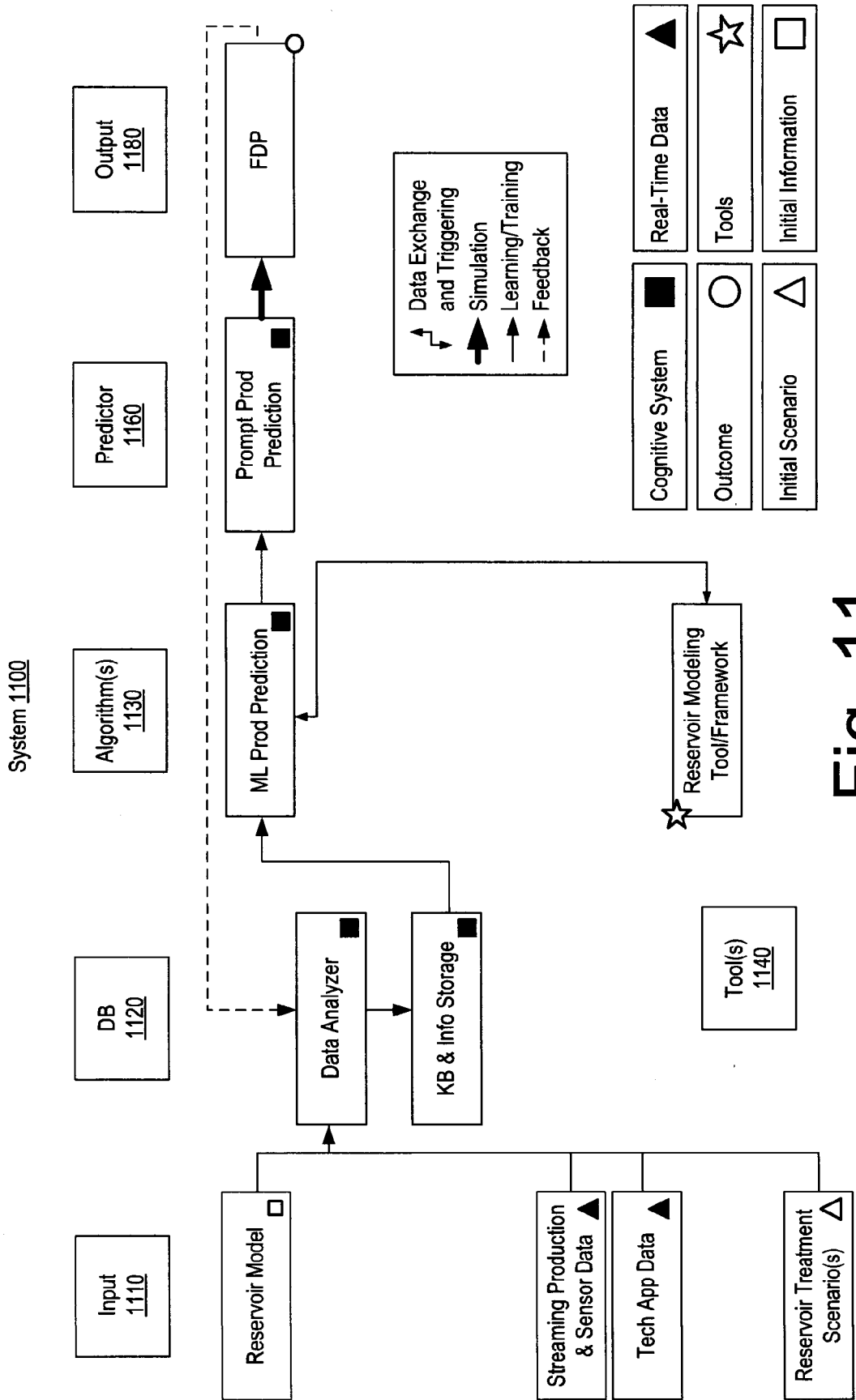

Fig. 11

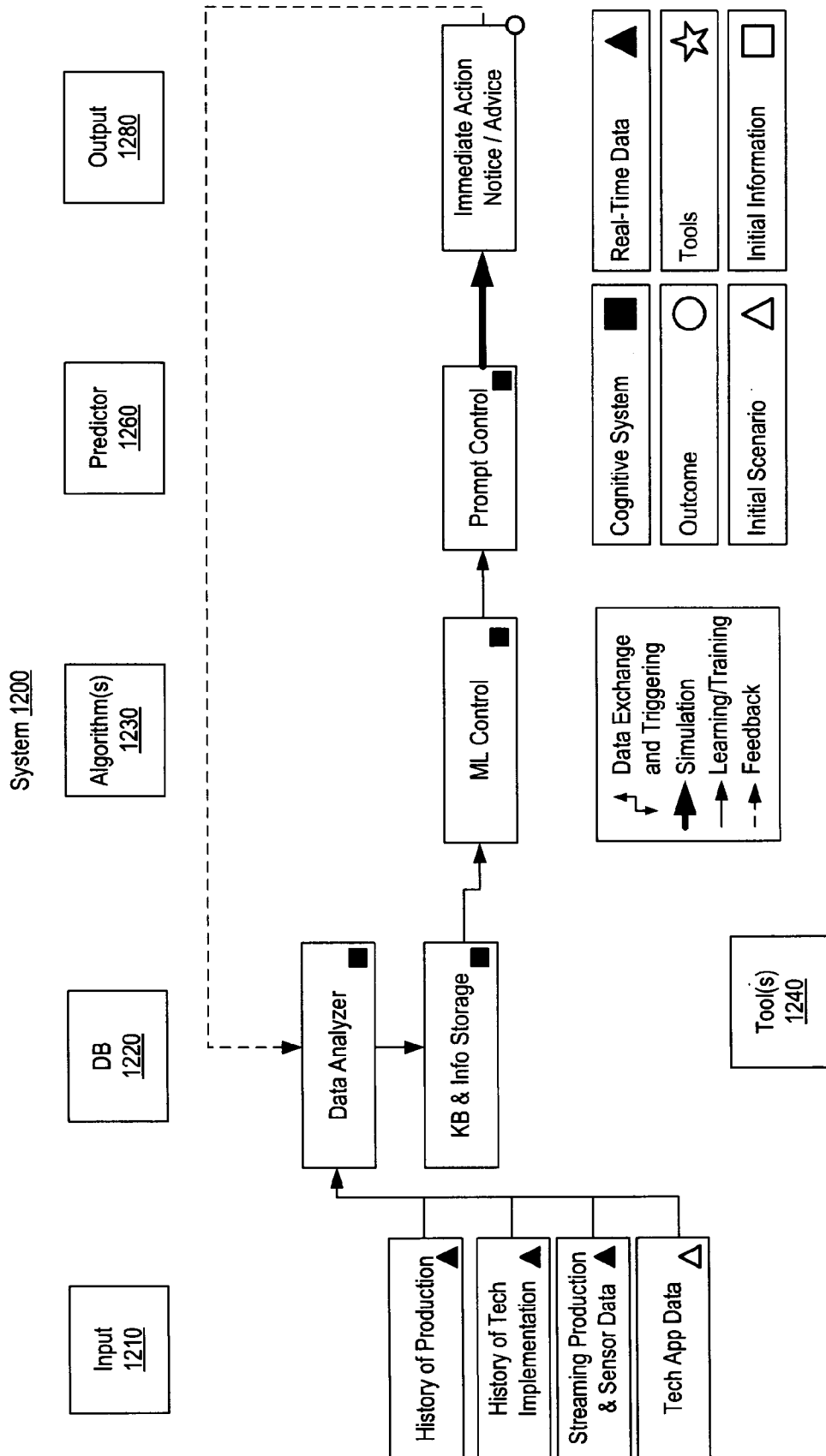

Fig. 12

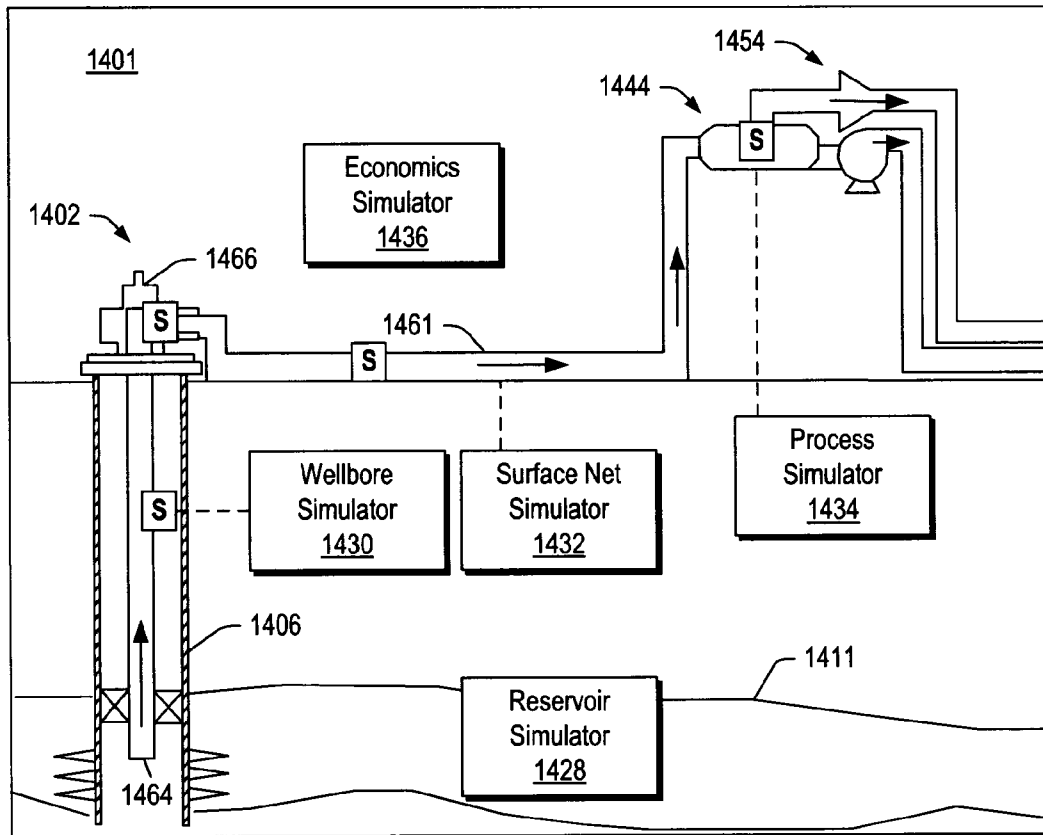
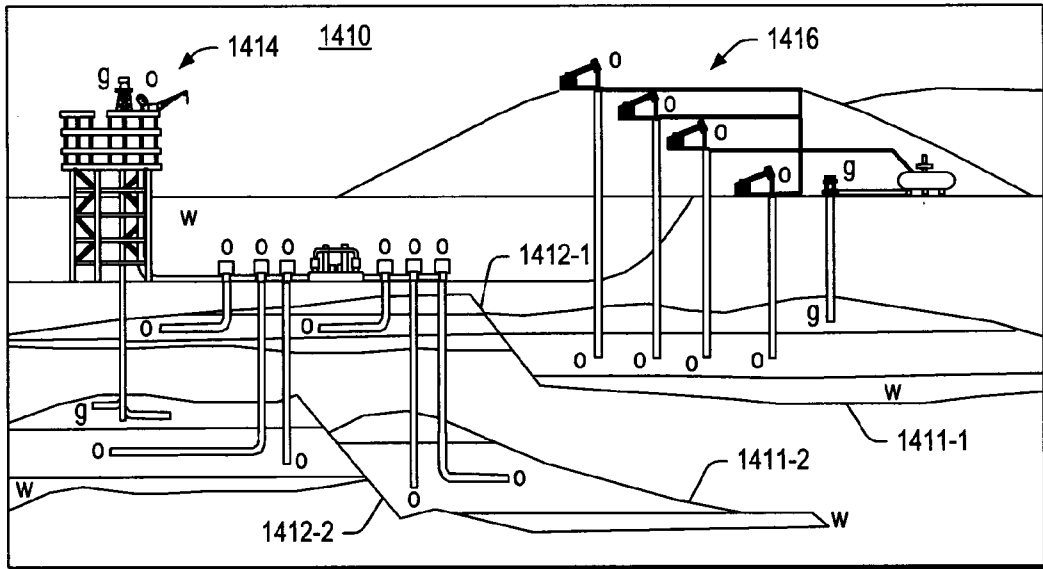

Fig. 14

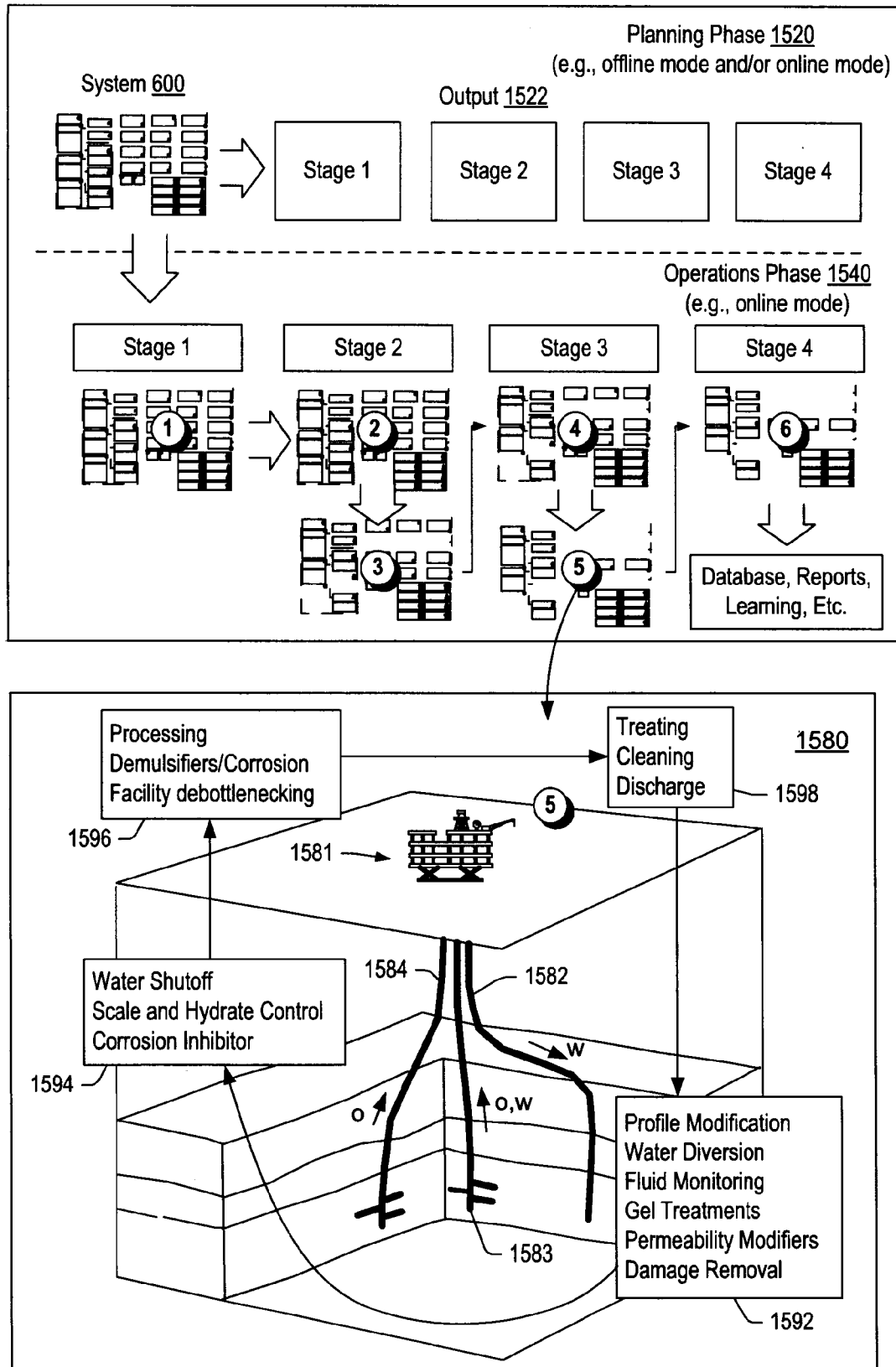

Fig. 15

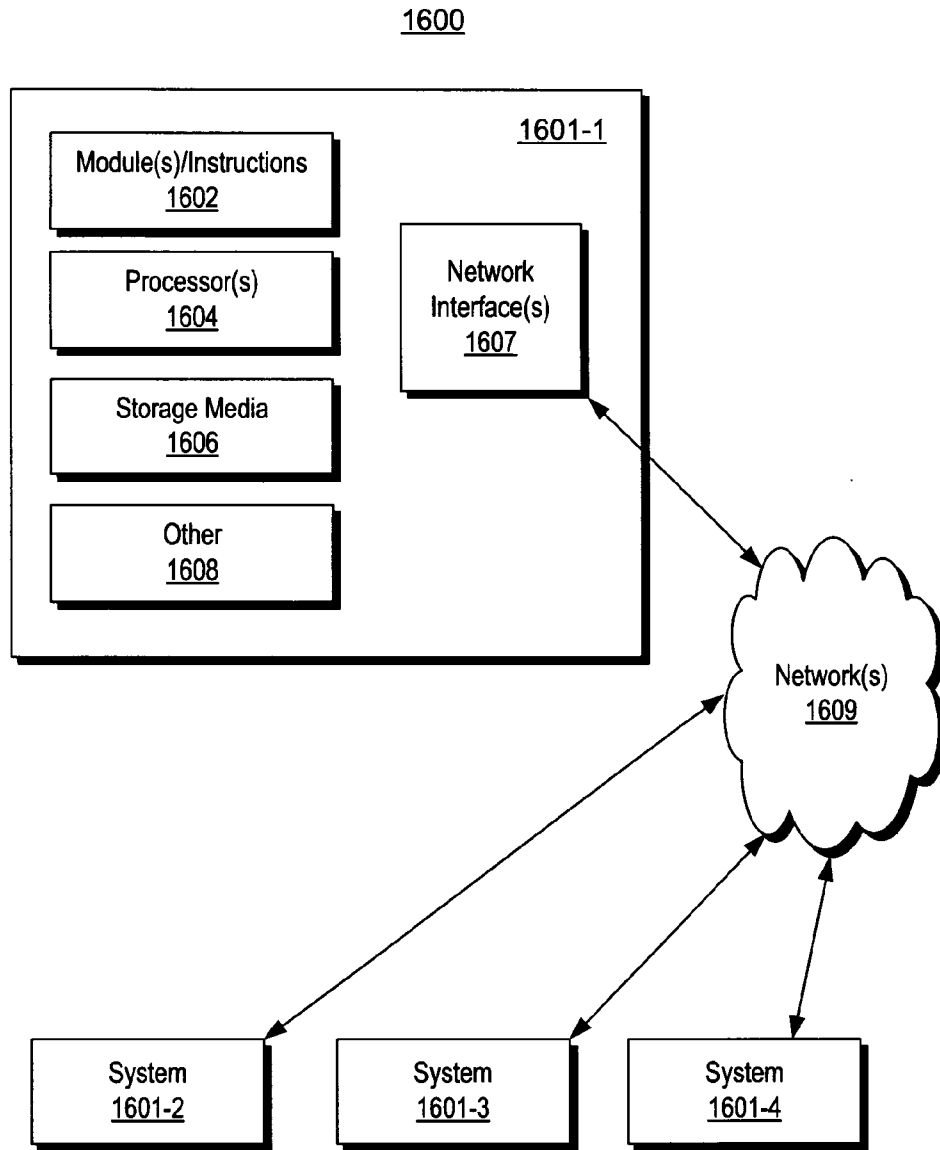

Fig. 16

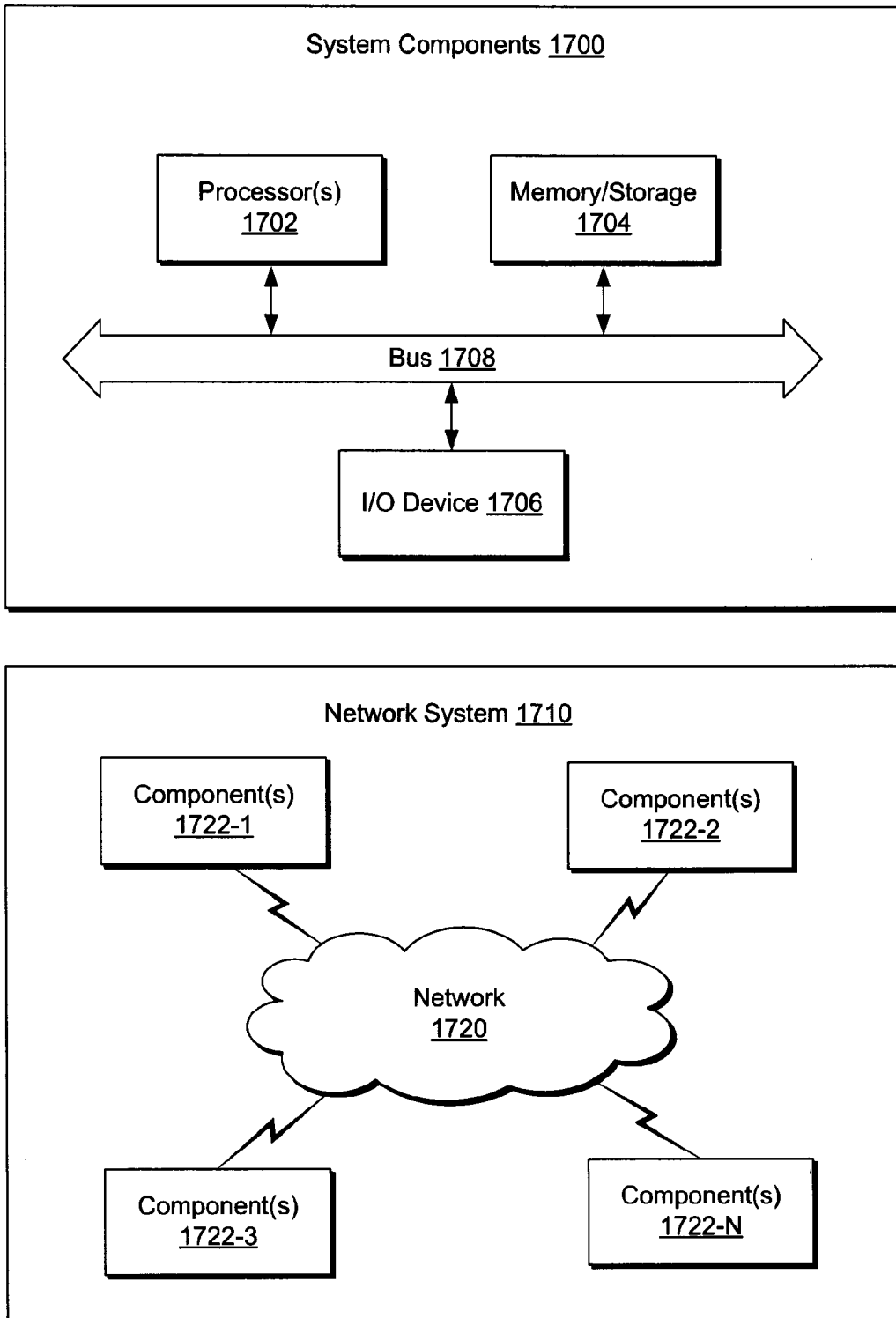

Fig. 17

INTERNATIONAL SEARCH REPORT

International application No.

PCT/RU 2017/000264

A. CLASSIFICATION OF SUBJECT MATTER		
<i>G01V 1/30 (2006.01)</i> <i>G06F 17/50 (2006.01)</i>		
According to International Patent Classification (IPC) or to both national classification and IPC		
B. FIELDS SEARCHED		
Minimum documentation searched (classification system followed by classification symbols)		
G06F 1/00-17/50, G06Q 10/00-50/34, H04L 9/00-9/38, 12/00-12/955, E21B 41/00-47/26, G06N 3/00-99/00, G01V 99/00, G06G 7/00-7/80		
Documentation searched other than minimum documentation to the extent that such documents are included in the fields searched		
Electronic data base consulted during the international search (name of data base and, where practicable, search terms used)		
PatSearch (RUPTO internal), USPTO, PAJ, Esp@cenet, DWPI, EAPATIS, PATENTSCOPE		
C. DOCUMENTS CONSIDERED TO BE RELEVANT		
Category*	Citation of document, with indication, where appropriate, of the relevant passages	Relevant to claim No.
X	US 2013/0118736 A1 (ADAM USADI et al.) 16.05.2013, abstract, par. [0015], [0018]-[0020], [0052], [0055], [0057], [0061], [0066]-[0074], [0077], [0080], [0097], [0110], [0103], [0107]	1-20
A	US 6901391 B2 (HALLIBURTON ENERGY SERVICES, INC, et al.) 31.05.2005	1-20
A	US 2012/0000669 A1 (WU XIAO-HUI et al.) 05.01.2012	1-20
A	US 2013/0096899 A1 (USADI ADAM et al.) 18.04.2013	1-20
A	RU 2573746 C2 (EXXONMOBIL UPSTREAM RESEARCH COMPANY) 27.01.2016	1-20
<input type="checkbox"/> Further documents are listed in the continuation of Box C. <input type="checkbox"/> See patent family annex.		
* Special categories of cited documents:		
“A”	document defining the general state of the art which is not considered to be of particular relevance	“T” later document published after the international filing date or priority date and not in conflict with the application but cited to understand the principle or theory underlying the invention
“E”	earlier document but published on or after the international filing date	“X” document of particular relevance; the claimed invention cannot be considered novel or cannot be considered to involve an inventive step when the document is taken alone
“L”	document which may throw doubts on priority claim(s) or which is cited to establish the publication date of another citation or other special reason (as specified)	“Y” document of particular relevance; the claimed invention cannot be considered to involve an inventive step when the document is combined with one or more other such documents, such combination being obvious to a person skilled in the art
“O”	document referring to an oral disclosure, use, exhibition or other means	“&” document member of the same patent family
“P”	document published prior to the international filing date but later than the priority date claimed	
Date of the actual completion of the international search		Date of mailing of the international search report
29 August 2017 (29.08.2017)		21 September 2017 (21.09.2017)
Name and mailing address of the ISA/RU: Federal Institute of Industrial Property, Berezhkovskaya nab., 30-1, Moscow, G-59, GSP-3, Russia, 125993 Facsimile No: (8-495) 531-63-18, (8-499) 243-33-37		Authorized officer V. Zhakovich Telephone No. 8-499-240-25-91