

(No Model.)

R. J. COSTAIN.

ROLLER SKATE.

No. 337,742.

Patented Mar. 9, 1886.

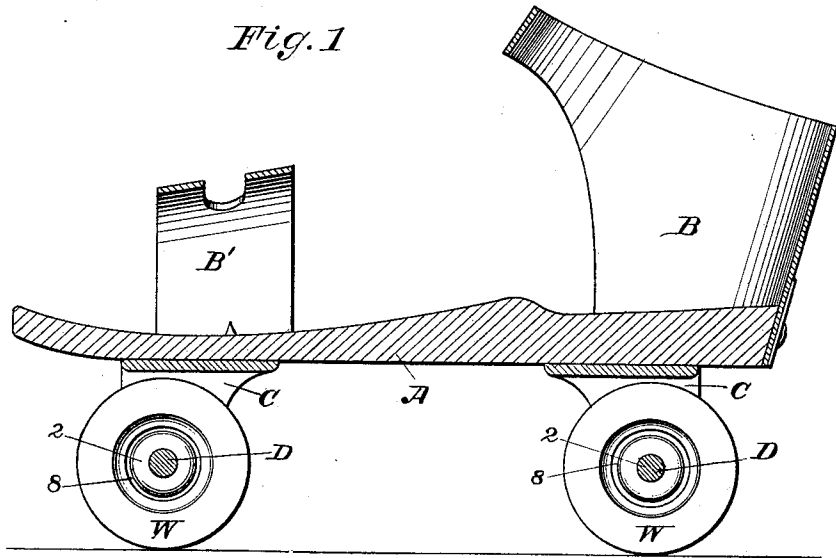
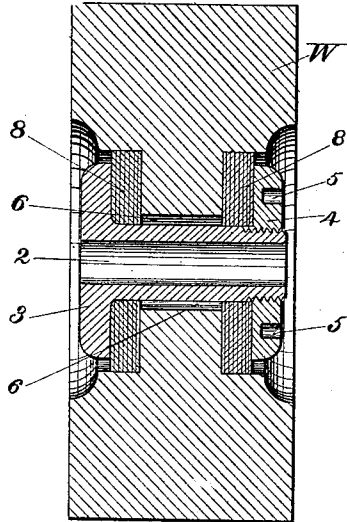

Fig. 2



Witnesses:
Frank N. Pierpont
C. O. Palmer.

Inventor:
Richard J. Costain,
By F. H. Richards,
Attorney.

UNITED STATES PATENT OFFICE.

RICHARD J. COSTAIN, OF HARTFORD, CONNECTICUT, ASSIGNOR OF ONE-HALF
TO AMOS WHITNEY, OF SAME PLACE.

ROLLER-SKATE.

SPECIFICATION forming part of Letters Patent No. 337,742, dated March 9, 1886.

Application filed August 10, 1885. Serial No. 174,031. (No model.)

To all whom it may concern:

Be it known that I, RICHARD J. COSTAIN, a citizen of the United States, residing at Hartford, in the county of Hartford, State of Connecticut, have invented new and useful Improvements in Roller-Skates, of which the following is a specification, reference being had to the accompanying drawings, in which—

Figure 1 is a longitudinal sectional view of a skate embodying my improvements. Fig. 2 is a cross-section through one of the rollers thereof.

The object of my invention relating to roller-skates is to improve the rollers with which such skates are provided, so as to prevent, in a large degree, the vibrations of the rollers on uneven floors from being communicated to the foot of the skater.

To this end the invention consists in the improvements hereinafter described and claimed.

Similar characters designate the same parts in each figure.

A designates the foot-rest or body of the skate; B B', respectively, the heel and toe straps, and C the hangers, secured upon the lower side of body A and supporting axles D. Each axle D is provided with one or two rollers, W, usually loosely mounted thereon. Each roller is provided with a central bush, 2, fitting the axle. At one end this bush has a flange, 3, Fig. 2, and at the other end a flange or nut, 4, provided with holes 5, or with other means whereby it may be screwed onto and off from the bush. The roller W is bored larger than the tubular part of the bush, leaving an annular space, as at 6, which bore is enlarged at either end to receive an elastic cushioning-disk, 8. By means of the aforesaid nut these disks 8 8 are compressed against the sides of

the central part of the wheel until the said disks are sufficiently firm to properly support the weight of the skater and to prevent the bush from coming in contact with the lower side of the bore of the wheel.

For making the disks 8, I use vulcanized india-rubber of about the consistency ordinarily used for springs, making them of a size graduated according to the size of the skate. In practice, when skating on uneven floors—and few floors are even—these disks permit the rollers to always come to a proper bearing, thereby preventing the so rapid wearing away of their edges. The better contact thus obtained of the rollers on the floor increases their holding power and enables the skater to maintain a better control over his movements, with less danger of accident from losing his foothold.

Having thus described my invention, I claim—

1. The combination, in a roller-skate, and with the axles thereof, of rollers, each provided in their bores with a flanged bush smaller than their bore, and a pair of elastic cushioning-disks between the roller and the bush, substantially as set forth.

2. The combination, in a roller-skate, and with the axles thereof, of rollers, each provided in their bores with a bush having one fixed and one adjustable flange, and a pair of elastic cushioning-disks between the rollers and the said bush, said disks being held in compression by the said flanges, substantially as shown and described.

RICHARD J. COSTAIN.

Witnesses:

F. H. RICHARDS,
C. O. PALMER.