

Feb. 25, 1969

B. G. BLEVENS

3,429,489

FORM FINISHER AND BAG FOR USE THEREWITH

Filed July 5, 1967

Sheet 1 of 5

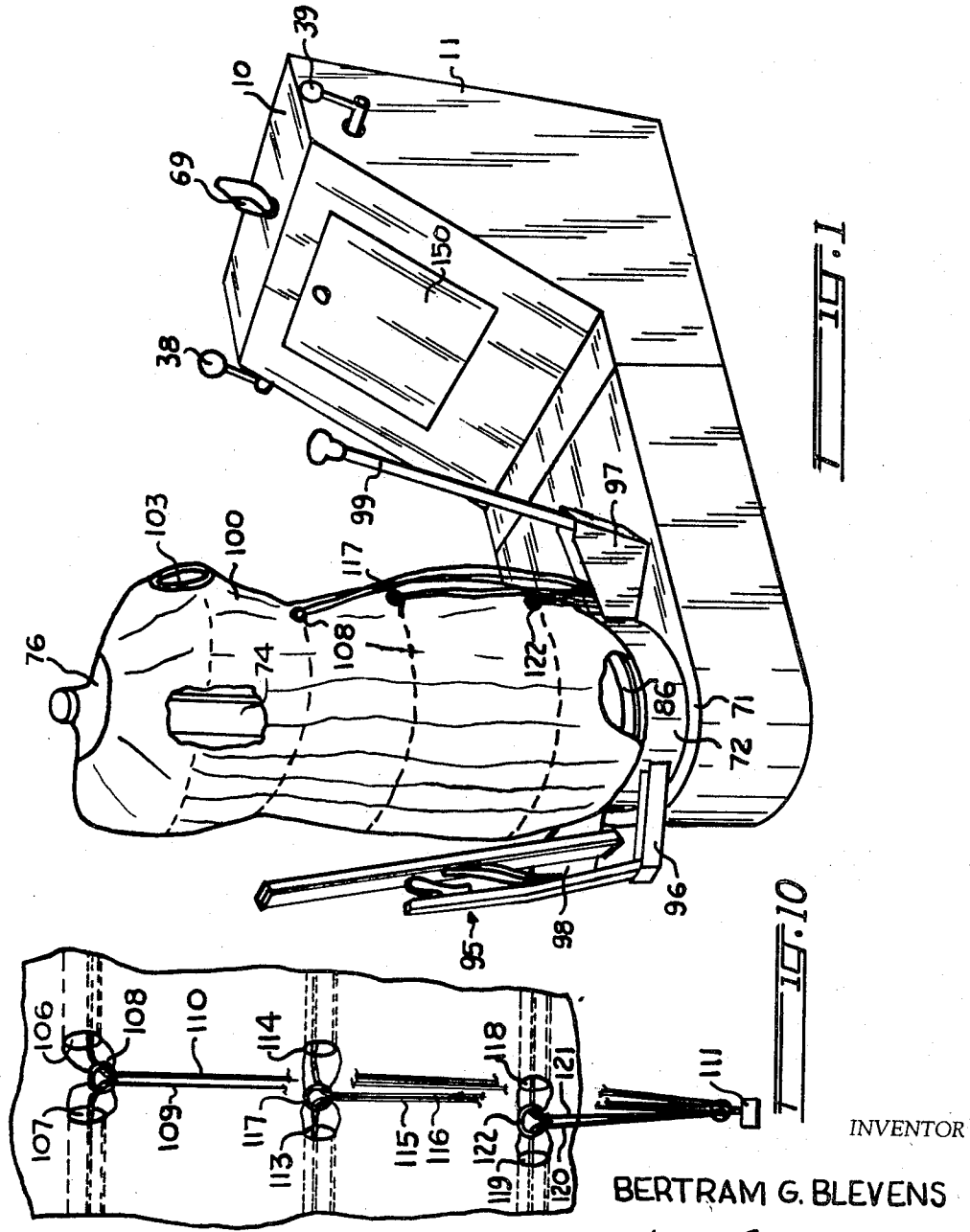

FIG. 1

FIG. 10

INVENTOR

BERTRAM G. BLEVENS

BY

W. E. Sherwood

ATTORNEY

Feb. 25, 1969

B. G. BLEVENS

3,429,489

FORM FINISHER AND BAG FOR USE THEREWITH

Filed July 5, 1967

Sheet 2 of 5

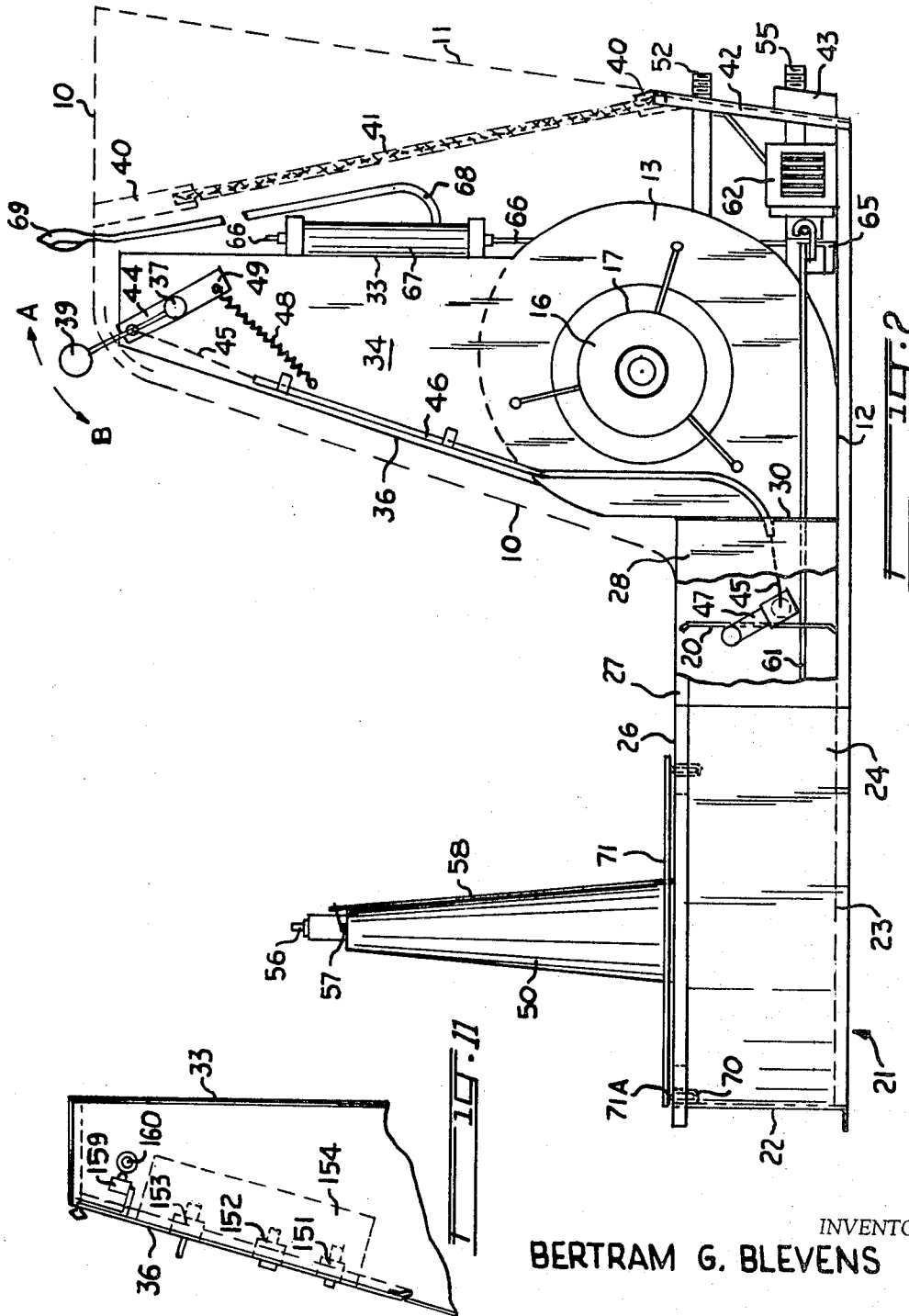

INVENTOR
BERTRAM G. BLEVENS

BY *W. E. Sherwood*
ATTORNEY

Feb. 25, 1969

B. G. BLEVENS

3,429,489

FORM FINISHER AND BAG FOR USE THEREWITH

Filed July 5, 1967

Sheet 3 of 5

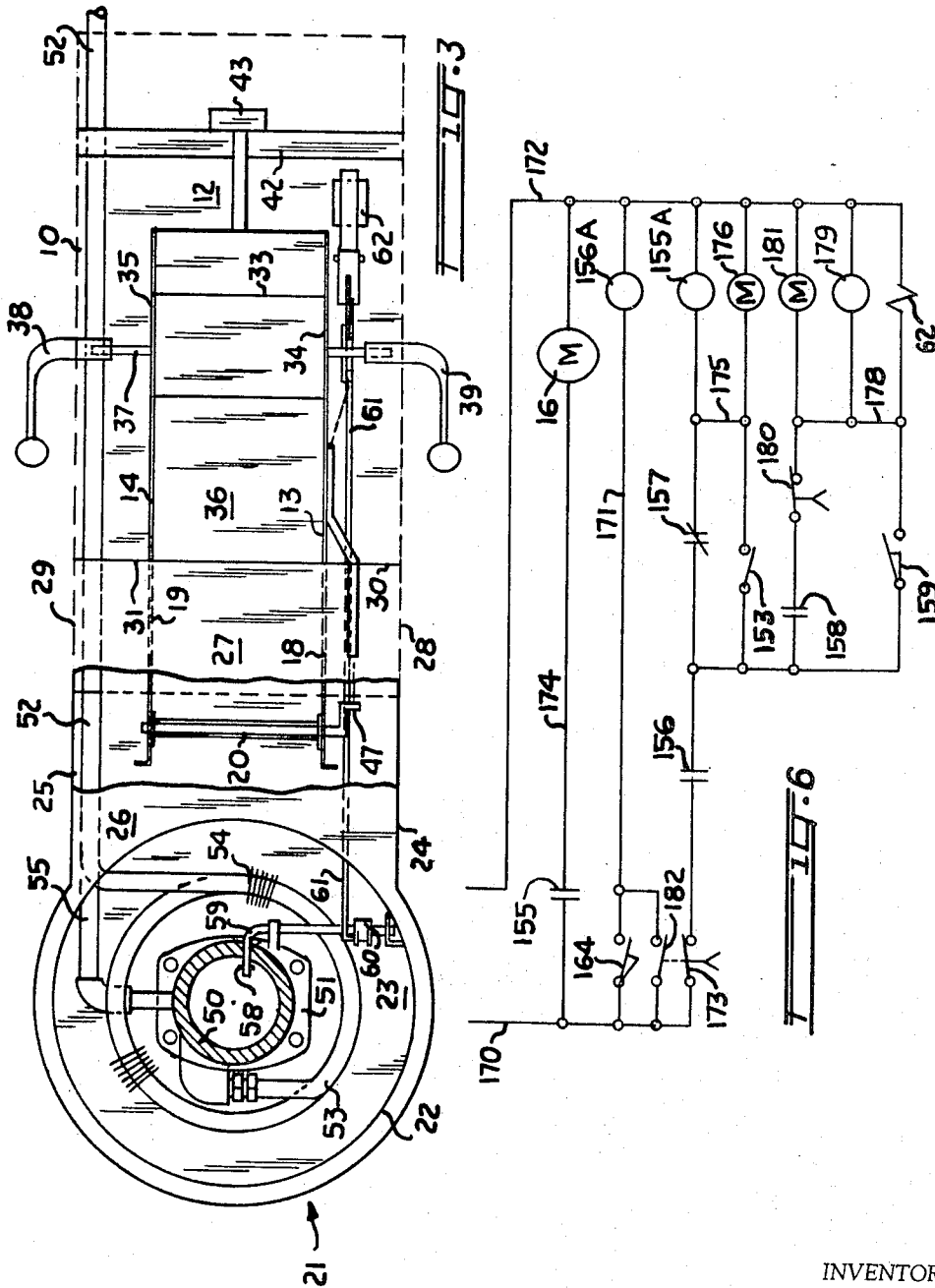

INVENTOR
BERTRAM G. BLEVENS

BY *W. E. Sherwood*
ATTORNEY

Feb. 25, 1969

B. G. BLEVENS

3,429,489

FORM FINISHER AND BAG FOR USE THEREWITH

Filed July 8, 1967

Sheet 4 of 5

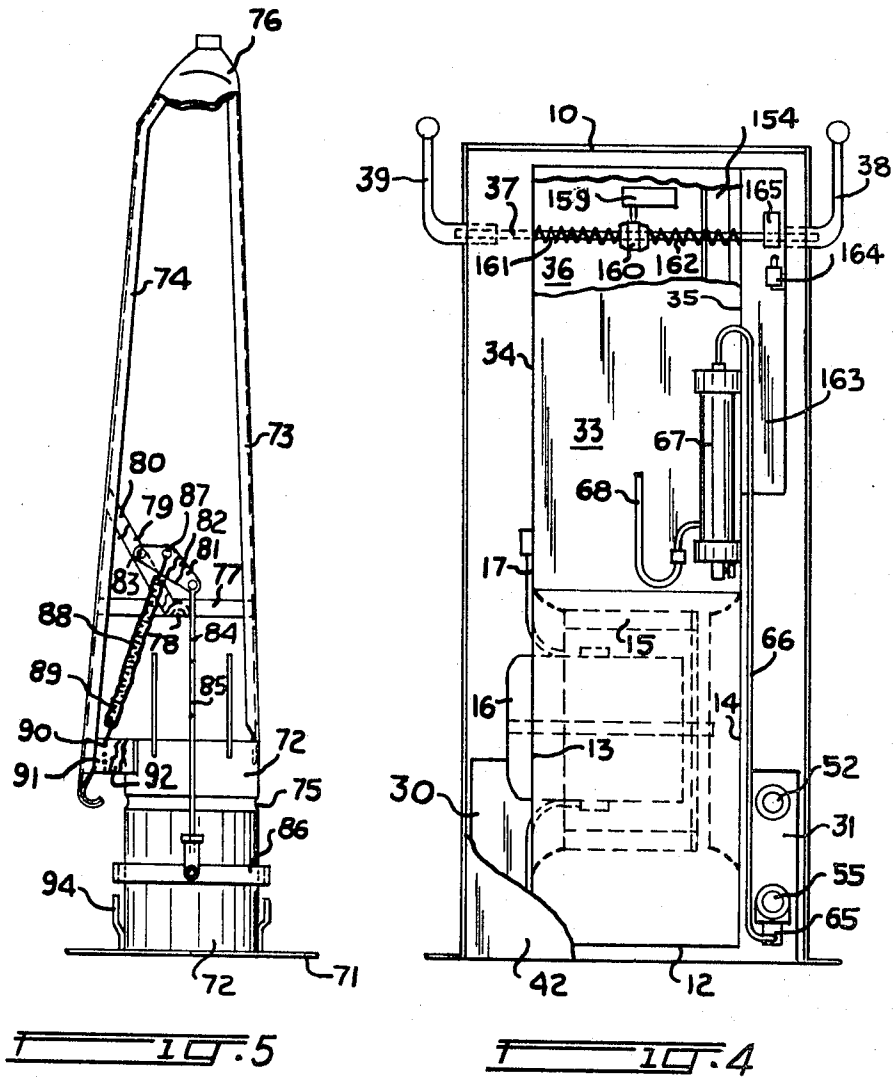

INVENTOR
BERTRAM G. BLEVENS

BY *W. E. Sherwood*
ATTORNEY

Feb. 25, 1969

B. G. BLEVENS

3,429,489

FORM FINISHER AND BAG FOR USE THEREWITH

Filed July 5, 1967

Sheet 5 of 5

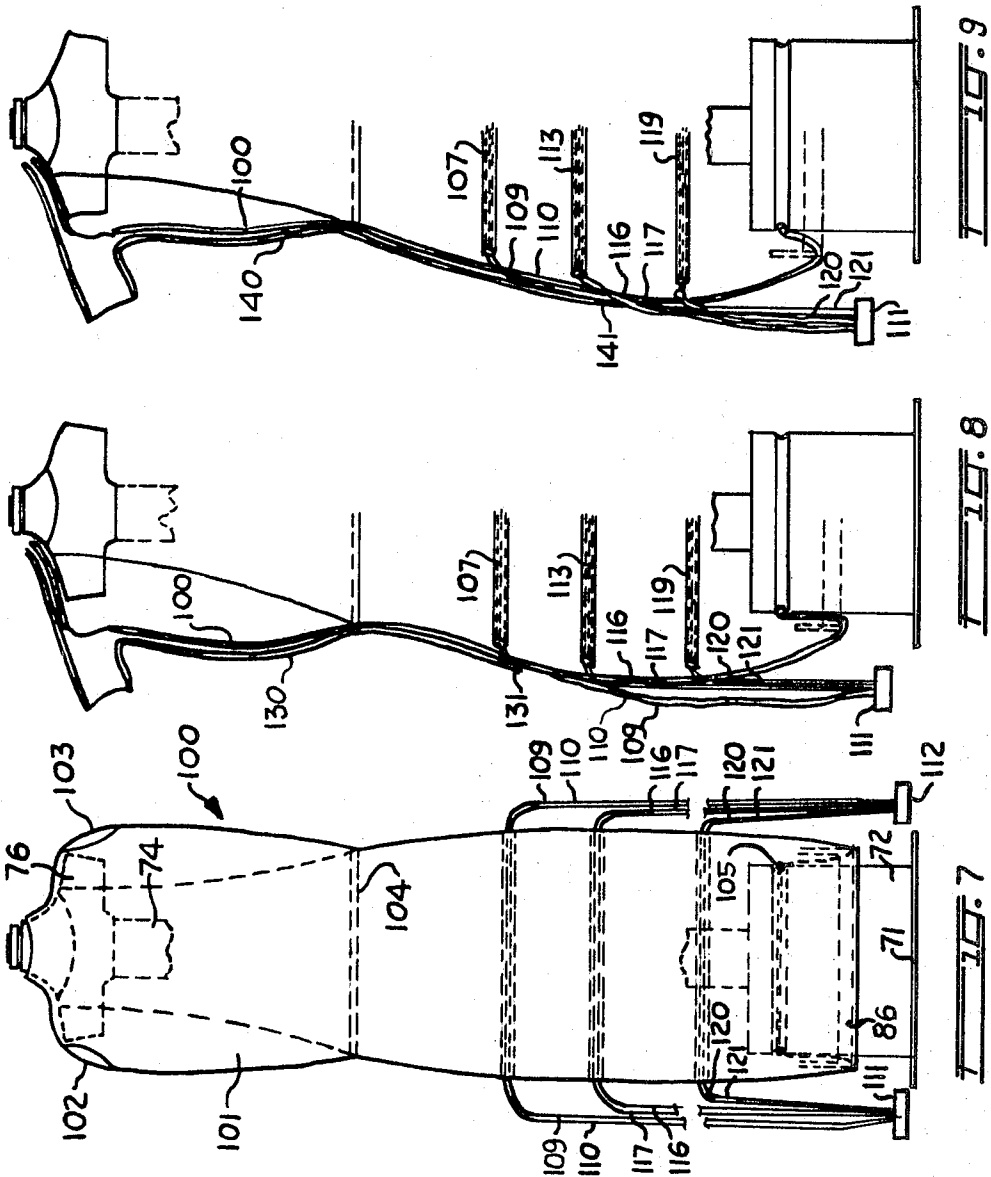

INVENTOR
BERTRAM G. BLEVENS

BY

W. E. Sherwood

ATTORNEY

1

2

3,429,489

FORM FINISHER AND BAG FOR USE THEREWITH
Bertram G. Blevens, Louisville, Ky., assignor to W. M.
Cissell Manufacturing Company, Louisville, Ky., a cor-
poration of Kentucky

Filed July 5, 1967, Ser. No. 651,307
U.S. Cl. 223-67
Int. Cl. A41h 5/02

13 Claims

ABSTRACT OF THE DISCLOSURE

A form finisher employing a gas-pervious, flexible inflatable bag to which processing gases, including filtered air, under pressure are selectively supplied to finish garments of various sizes and materials disposed in enveloping relation upon the bag. The inflation of the bag portion which is not enveloped by the garment is controlled by the balance established between the gas pressure within the bag and the weight of a pair of masses supported by the bag and disposed exteriorly thereof.

BACKGROUND OF THE INVENTION

Field of the invention

The invention relates to the treating of garments with steam and hot air to remove wrinkles therefrom and to finish the garment in its proper shape. An apparatus is provided for selectively supplying the processing gases to an inflatable bag on which the garment is disposed, and at appropriate pressures and for appropriate lengths of time. The bag itself is so constructed as to cooperate with an adjustable storage ring of the apparatus in effecting the storage of bag material not required for a given size of garment, and to cooperate with a pair of masses, the weights of which serve to establish a balance with the pressure of a gas within the bag, thereby to effect a self-regulating action with respect to the maximum size to which portions of the bag can distend during the finishing of a garment of given size.

Description of the prior art

Conventional apparatus as illustrated by my copending application Ser. No. 485,338 filed Sept. 7, 1965, now Patent No. 3,332,588 either employs a storage ring interiorly of the bottom portion of the bag in conjunction with manipulatable means for adjusting the peripheral size to which the bag may inflate or may employ a weight disposed interiorly of the bag and adapted to restrain the peripheral expansion of the bag as a whole and as taught by the patents of Richa et al. 2,459,962; Locke et al. 2,378,565; and Petzold et al. 2,986,312. It is generally recognized, however, that in order to prevent "bell-ing" of the bag and the undesirable flaring of the lower edge of the garment being processed, the maximum diameter of the inflated bag in its portions which are not enveloped by the garment should not substantially exceed the maximum diameter of the adjacent upper portion of the inflated bag, and that apparatus such as exemplified by the above patents provides only a partial solution to this problem. It is an object of my invention to provide a form finisher in which the use of manipulatable, bag-attached means for regulating the peripheral size of the bag is no longer required, and in which the size of the inflated bag is self-regulated while at the same time avoiding the "bell-ing" effect. In addition, it is a purpose of the invention to provide for an independent sizing of the bag to each garment at the start of the finishing operation.

SUMMARY OF THE INVENTION

The invention relates to a form finisher and to the bag employed therewith and embodies a bag construction enclosing a ring member adapted to pay out bag material as needed, together with a pair of externally suspended masses of substantially equal weight affixed to one or more draw strings acting to collapse the bag peripherally thereof in opposition to the pressure of processing gases within the bag. The filtered air supplied to the bag from a blower is controlled by a damper which is adjusted to its proper setting corresponding to the sizing of the bag to a particular garment at the beginning of each finishing operation. An electrical circuit provides for timed supply of air and of steam. A multi-purpose manually operable lever assembly adjusts the damper setting; starts the operating cycle; serves to cancel the cycle of operation; and also serves to start the supply of steam when such lever assembly is moved in its prescribed directions.

Among the objects of the invention are the provision of compactly housed assembly of mechanical parts; the provision of an improved form finisher bag and frame for supporting the bag and a storage ring; and the provision of an improved control means for the operator embodying electrical circuitry which permits the supplying to the bag of air alone, of air and steam simultaneously, or of steam followed by air.

BRIEF DESCRIPTION OF THE DRAWINGS

The objects of the invention will be more apparent when considered in conjunction with the accompanying drawings in which:

FIG. 1 is a perspective view of the form finisher apparatus with parts broken away, and with the bag in a collapsed wrinkled position.

FIG. 2 is a side elevation view of the stationary housing of the apparatus with the rotatable form removed and with parts broken away, and with the removable shroud indicated in dotted lines.

FIG. 3 is a plan view of the housing shown in FIG. 2 with parts broken away and with the steam column shown in section and with the shroud indicated in dotted lines.

FIG. 4 is an end elevation of the housing shown in FIG. 2 with the filter removed but with the shroud in place.

FIG. 5 is a side elevation view of the inner frame of the form with the bag removed and with the storage ring in its lowermost position.

FIG. 6 is a schematic control diagram of the electrical circuit for the apparatus.

FIG. 7 is a diagrammatic view of a bag embodying the invention and showing the normal relative positions of the storage ring and of the pair of masses when the bag has no garment thereon.

FIG. 8 is a diagrammatic view of a portion of the bag enveloped by a short garment and showing the relative positions of the ring and pair of masses during the finishing of that garment.

FIG. 9 is a diagrammatic view of a portion of the bag enveloped by a long garment and showing the relative positions of the ring and pair of masses during the finishing of that garment.

FIG. 10 is a side elevation view to a larger scale showing a portion of the bag construction and draw strings, and

FIG. 11 is a side elevation view of the closure plate for the casing and indicating in dotted lines the mounting of electrical components for the control circuit of FIG. 6.

DESCRIPTION OF THE PREFERRED EMBODIMENT

Referring now to FIGS. 1 and 2, a compact apparatus in which the invention may be embodied includes a sta-

tionary housing, a portion of which is covered by a removable filter-supporting shroud 10 having an open rear end 11. Supported upon the floor 12 of the housing is a blower scroll having side walls 13, 14 with openings therein through which air is drawn by a blower 15 driven by electrical motor 16. The motor-blower assembly may conveniently be of the double entry type P90-6 HPI100 SWDD available from Morrison Products, Inc., Cleveland, Ohio, and may be supported as a unit by means of a bracket harness 17 mounted upon the wall 13 of the scroll.

Air discharged from the blower passes through an interior duct bounded by wall extensions 18, 19 in which a damper 20 is pivotally mounted. A form finisher base assembly indicated generally at 21 includes a generally circular wall 22 surrounding floor 23 and merging into side walls 24, 25 which extend toward the blower scroll and which are attached to cover plate 26. As will be noted from FIG. 3, walls 24, 25 lie outboard of the inner duct walls thus to provide longitudinally extending spaces for enclosing elements later to be described. A housing section having a cover portion 27, side walls 28, 29 and inturned end walls 30, 31 surrounds the inner duct and confines air and steam used in the finishing operation.

Mounted upon the blower scroll is a hollow closed casing having a generally vertical rear wall 33, side walls 34, 35 and an inclined front closure plate 36 serving as a mount for various control elements as later to appear. These side walls provide a mounting for an oscillatable and longitudinally slidable control shaft 37. The ends of this shaft terminate inboard of the side walls of the shroud 10, but by means of handle extensions 38, 39 detachably secured to the respective ends of the shaft and passing through holes in that shroud, the shaft can readily be manipulated with the shroud in place. The interior of this shroud, moreover, is provided with a peripheral framework 40 (FIG. 2) adapted to support a conventional flat filter 41 so that all air entering the apparatus is filtered before reaching the blower. The filter preferably is disposed above an upwardly extending plate 42 attached to the floor 12 and providing a support for a connection box 43 into which electrical lines are directed.

Attached to the control shaft 37 is a multi-purpose lever, one arm 44 of which is connected to a wire 45 housed in a flexible tube 46 mounted on the walls 34 of the casing and passing through the end wall 30 of the housing section. The other end of this wire is connected to an arm 47 rigidly affixed to the shaft of damper 20 with the result that full movement of either of the handles 38, 39 in the direction indicated by A (FIG. 2) will effect a closing action of the damper and movement indicated by the direction B will open that damper. A tension spring 48 anchored at one end upon the casing wall 34 and at the other end upon the arm 49 of the lever serves to oppose any additional opening of the damper, due to the flow of air under pressure, after the bag has been sized to the garment.

The base assembly includes the conventional hollow steam column 50 mounted upon pad 51 above the floor 23 and into the lower portion of which live steam is conducted from steam supply pipe 52 after traversing a helical pipe 53 having radiating fins 54. Condensate collecting in the steam columns passes through the steam return pipe 55 which is connected to a lower portion of the column and which is at a lower elevation than the steam supply pipe, as best shown in FIG. 4. The upper end of the steam column provides a support 56 for the form finisher frame later to be described, and includes a solenoid-operated valve 57 for venting steam from the column. This valve, which is biased to normally closed position, is opened by downward movement of rod 58 which is connected at its lower end to one arm 59 of a bellcrank, the other arm 60 of which is connected to an elongated rod 61. This rod 61 extends through wall 30 of the housing section and is connected at its distal end to the core

of solenoid coil 62 mounted on the floor of the housing adjacent plate 42.

By means of a suitable fitting 65 attached to steam return pipe 55, condensate collecting therein is forced through a small diameter tube 66 and into the top of a receiver 67 mounted on the back wall 33 of the casing, as best shown in FIG. 4. An elongated hose 68 with a generous amount of slack is connected to a lower portion of this receiver and to a conventional spray gun 69 (FIG. 1) which is adapted to rest above an aperture for that hose as provided in the shroud 10, and to be pulled outwardly by the operator when spraying of a garment is desired. It will further be noted that the steam pipes 52, 55 are supported in the rear walls 31 of the intermediate housing portion and in the plate 42 and that when the shroud 10 is in place those pipes are hidden and cannot touch an operator performing his duties at the machine. Moreover, the mechanism for operating the damper, as well as the solenoid operated mechanism, likewise are covered when the shroud is in place. In addition, air passing through the filter flows into contact with the receiver 67 and assists in condensing any steam passing thereto.

As indicated in FIG. 2, the wall 22 of the base assembly is provided with a circular recess 70 surrounding its upper opening and in which a suitable gasket 71A is disposed. This gasket serves to seal the bottom surface of the plate 71 of the rotatable frame (FIG. 5) of the finisher form and as now to be described. In contrast with conventional structures and due in large part to the bag construction herein disclosed, the frame is characterized by its simplicity and includes the annular plate 71 having a vertical annular wall 72 extending upwardly a suitable distance, for example about thirteen inches, to accommodate the bag storage and within which wall the processing fluids may pass from the base assembly into the bag. Upwardly extending rear and front members, 73 and 74 respectively, are rigidly affixed to the upper portion of the annular wall and above a circular groove 75 therein which is employed in the fastening of the bag. At their upper ends these members are rigidly affixed to a shoulder and neck form generally shown at 76 and preferably of the type disclosed in Richterkessing Patent No. 3,033,429. A wide crossbrace 77 having a suitable cup 78 for supporting the frame upon the support 56 of the steam column, rigidly joins the members 73, 74, and a pair of inclined braces 79, 80 spaced from each other, join the front member 74 to the crossbrace 77. A toggle arrangement comprising a pair of spaced arms 81, 82 pivoted at one end on a pin 83 extending between the inclined braces is adapted to support a pair of downwardly extending rods 84, 85 which are pivotally connected at their lower ends to diametrically opposite sides of the storage ring 86. A central pin 87 extending between the arms 81, 82 provides one anchor for a pair of tension springs 88, 89 which are suitably anchored at their other ends to a lower pin 90 extending between a pair of spacers 91, 92 joining the lower end of the front member 74 to wall 72.

Affixed to wall 72 immediately above the bottom plate 71 is a front bracket 94 adapted to support a detachable front clamp assembly 95 (FIG. 1) and which may be of the type disclosed in Richterkessing Patent 2,948,443 and provided with an adapter 96 which serves to engage with and to disengage from the bracket 94. A similar rear bracket for a rear clamp assembly may also be provided. Also, as seen in FIG. 1, a pair of diametrically located shields 97 and 98 for the suspended bag-sizing-control masses are rigidly attached to the wall 72 below the lowermost position occupied by the storage ring 86. An upwardly extending handle 99 affixed to the shield 97 is provided for ease in manually rotating the form. Both the clamp assembly 95 and this handle are so mounted that complete rotation can be effected without interference with shroud 10.

Referring now to FIGS. 7 to 10, a bag 100 which may comprise nylon or similar gas pervious material includes a bodice portion 101 with arm openings 102, 103 for passing air into the sleeves of garments and for receiving extensions of the neck and shoulder element of the frame. The bag also includes front and rear internal suspender portions supported upon that neck and shoulder element and attached at their lower ends to the bag by stitch lines 104 adjacent to the waist of the bag. At its lower end the bag includes a tubular cloth section, herein called a "piping," and in which a tie string 105 is enclosed and which is adapted to be placed in the groove 75 after the storage ring is manually lifted out of the way during assembly of the form. As indicated by FIG. 5 lifting of ring 86 causes the toggle arms 81, 82 to pivot counterclockwise about pin 83 and when the spring anchor pin 87 passes center, the springs are effective to hold the ring upwardly and to permit the tie string 105 to be secured in place. Thereafter, the ring may be grasped from the exterior of the bag and lowered into its normal position in contact with the bag as shown in FIG. 7. As a significant feature, the force exerted by the ring in holding the lower end of the bag against "bellling out" due to pressure of gases within the bag, decreases as the ring is moved upwardly. It will be noted that as the ring and its suspension rods 84, 85 rise, the tension force of the springs 88, 89 increases, but a simultaneous reduction in the effective leverage between pins 83 and 87 also occurs. Thus the shape acquired by an inflated bag above its contact with the ring must be regulated by other means and it is a purpose of the invention to provide a simple and effective means for satisfying this requirement.

As best shown in FIG. 10, the bag is provided with an upper interior peripheral piping in two sections 106, 107 each extending substantially half way around the bag and terminating adjacent a pair of grommets in the opposite sides of the bag, one such grommet 108 being shown. Disposed within the respective pipings and grommets is a pair of drawstrings 109, 110 of equal length and which extend downwardly on the exterior of the bag and are attached at their lower ends to two masses 111, 112 of substantially equal weights. As an example, the upper piping may be located about 29 inches below the top of the frame and will normally be covered by a short jacket being processed on the form.

Similarly, a central piping in two sections 113, 114 encloses another pair of drawstrings 115, 116 passing through similar grommets, one of which is shown at 117. These drawstrings are of equal lengths but are shorter than drawstrings 109, 110 and are attached at their ends to the respective masses 111, 112. Following the above example, the central piping may be located about eight inches below the upper piping and will normally be covered by a full length garment, such as an overcoat.

In addition, a lower piping in two sections 118, 119 encloses a third pair of drawstrings 120, 121 passing through grommets, one of which is shown at 122. These drawstrings likewise are of equal length but are shorter than drawstrings 116, 117 and are attached at their ends to the respective masses 111, 112. As in the above example, the lower piping may be located about seven inches below the central piping and normally will not be covered by the garment.

As will now be evident, the shape desired for an inflated bag before the garment is placed thereon may be determined by the choice of lengths of the upper, central, and lower drawstrings since these drawstrings share a common loading of the masses 111, 112 and since the pressure of air within an inflated bag will lift the storage ring 86 and dispense sufficient bag material until the respective drawstrings become taut. For convenience, this arrangement is defined as means for self-regulating the expanded size of the bag, and results in the avoidance of the bellling of a garment while being processed on the machine.

When air under pressure is supplied to the bag shown in FIG. 8 with a relatively short garment 130 thereon, and in the manner later to be described, the lower edge 131 of the garment usually will envelop the upper piping and the resistance to flow of air through both the garment and the bag will be greater than the resistance through the bag alone. Accordingly, the bag tends to distend laterally to a greater extent below the edge 131 of the garment and central drawstrings 109, 110 become slack. As this occurs the central drawstrings 116, 117 and the lower drawstrings 120, 121 then share the entire weight of the masses 111, 112 which meanwhile have been lifted and displaced outwardly. A balancing of air pressure against the weight of the masses thus takes place and which not only limits the bag displacement but which also is entirely self-regulating and requires no manipulation on the part of the operator.

Similarly, when a full length garment 140 as seen in FIG. 9 is being processed, its lower edge 141 usually will envelop both the upper and central pipings, but not the lower piping. Accordingly, each of the upper and central drawstrings become slack and the lower drawstrings 120, 121 support the entire weight of the masses and prevents bellling of the garment. Meanwhile, these masses have been lifted and displaced even further, but, however, are still confined within the shields 97, 98.

As will be understood, the bag with its means for self-regulating its expanded size may be used on various machines in which air and steam are supplied under selective controls. In the present invention a control mechanism and an electrical system as best shown in FIGS. 1, 4, 6 and 11 is employed. The shroud 10 is provided with a pivoted panel 150 which when opened exposes the closure plate 36 (FIG. 2) on the sloping front surface of the housing above the blower. This closure plate (FIG. 11) mounts on its inner face a conventional air timer 151, steam timer 152 and sequence switch 153, the adjustments for which are manually made from the outer face of that closure plate. A panel 154 extending normally to the closure plate within the confines of the casing serves to mount the conventional relays indicated in FIG. 6. On the inner face of the closure plate centrally thereof the steam switch 159 for starting a selected cycle of operation is mounted and is adapted to be operated when a cam 160 carried by shaft 37 is dislodged from contact with the cam follower of that switch. This shaft is centered by means of compression springs 161, 162 interposed between the cam and the inner walls of the casing as best shown in FIG. 4. Plate 36 at one side includes a section 163 extending beyond the casing wall 35 and mounting an air switch 164 adapted to be actuated by an arm 165 rigidly attached to shaft 37 and when that shaft is fully rotated in the direction A of FIG. 2 by the multi-purpose lever assembly.

The operation of the apparatus as above described may now be noted from a study of FIG. 6. Assuming that a garment is in place upon the bag, the operator may employ various procedures in processing of that garment. If it is desired merely to supply heated air thereto, moving either of handles 38, 39 fully in direction A closes the air switch 164 after which a suitable movement of those handles in direction B opens the damper 20 the necessary amount to size the bag to the garment. When switch 164 closes, a circuit is made from line 170, closed switch 164, conductor 171, the coil 156A of a ratchet-type relay, herein called a main relay, and return line 172. This temporary circuit causes contacts 156 to close and to establish a holding circuit from line 170, normally closed switch 173 of the air timer, closed contacts 156, normally closed contacts of a second steam relay 157, the blower relay coil 155A, and return line 172. This holding circuit remains operative after the handles are moved to size the bag and after the temporary circuit is broken. When relay coil 155A is energized, the blower relay contacts 155 then close and a circuit is made through conductor 174, blower motor 16, and return line 172. At the same time a shunt

circuit is being made through conductor 175, air timer motor 176 and return line 172. If nothing further is done by the operator, hot air will be supplied to the garment until the air timer runs its cycle after which timer switch 173 interrupts the circuits to stop the blower. Moreover, contact 182 of the air timer switch operates coil 156A of the ratchet relay to reopen contact 156 thereof, thus to inactivate the circuit. In addition, if the operator desires to interrupt the supply of air before the timer runs its course, moving the handles in direction A to reclose switch 164 will cause the ratchet relay coil 156A to reopen contacts 156 and to interrupt the blower circuit.

Normally, however, the finishing of a garment requires steam to be supplied to the bag. The present invention provides alternative cycles by means of which this can be done depending upon the setting of the sequence switch 153. In the first alternative wherein steam is supplied followed by a timed supply of air, the operator closes switch 164 and sizes the bag to the garment and promptly thereafter pushes either of handles 38 or 39 axially of shaft 37. This movement, as will be seen from FIG. 4 causes steam switch 159 to close whereupon circuits are made from the closed contacts 156, through closed switch 159 and steam solenoid coil 62 to return line 172, and through conductor 178 and steam relay coil 179 to return line 172. When coil 179 is energized the contacts of first steam relay 158 close and a circuit also is made through the steam timer switch 180 and the steam timer motor 181. When coil 179 is energized it also serves to open the normally closed second steam relay contacts 157 and temporarily breaks the circuit to the blower relay for the motor 16.

After the steam timer then runs its cycle, switch 180 reopens and since the switch 159 also is open, the respective circuits to the solenoid 62, to the steam timer motor 181, and to the steam relay coil 179 also are interrupted. Deenergizing of relay coil 179, however, restores the relay contacts 157 to their normally closed position and the above-described circuits to the blower relay coil 155A and to the air timer motor 176 are reestablished whereupon the blower motor 16 again is energized and will run until the air timer completes its cycle at which time the switch 182 closes on its upper contact and energizes the ratchet relay coil 156A which then opens relay contacts 156.

In the second alternative in which air and steam are to be supplied simultaneously, the sequence switch 153 is first moved to its closed position in order to provide a shunt holding circuit for the air timer and blower motor. Thereafter the operator closes switch 164, sizes the bag, and pushes shaft 37 axially. In this case, circuits are made simultaneously through the blower motor 16, the air timer motor 176, the steam timer motor 181, the steam relay coil 179, and the steam solenoid 62. Should the operator desire to employ air alone following the supply of air and steam jointly, he then merely closes switch 164 as above described, sizes the bag, and omits any further axial shifting of shaft 37.

As will be noted from the foregoing, the invention is characterized by the fact that for each garment being processed the operation begins at a standard point, namely the movement of the handles 38, 39 to a position at which switch 164 is closed and that at such standard point the damper 20 is substantially closed. Thereafter, the bag is sized to the garment by movement of the handles so as to open the damper to the proper degree commensurate with the size, material, and degree of wear upon the garment. After being sized, the bag, due to its self-regulating means for controlling its expanded size, does not bell out under the garment.

Having thus described my invention by reference to one preferred embodiment of the same, it will be understood that the invention may be embodied in other forms within the scope of the appended claims.

What is claimed is:

1. A form for treating garments comprising an inflatable, gas-pervious bag having means at its upper end for engaging a supporting means whereby the bag may be suspended, said bag having an open lower end into which processing gases under pressure may be selectively supplied, and a pair masses of substantially equal weight suspended by a flexible drawstring means engaging an intermediate portion of the bag between its ends, the ends of said drawstring means being connected to the respective masses externally of said bag.

2. A form as defined in claim 1 wherein said drawstring means comprises a pair of strings of substantially equal lengths enclosed in a piping peripherally disposed within said bag and with said strings passing through openings at the diametrically opposite sides of said bag.

3. A form as defined in claim 2 wherein said drawstring means comprises a plurality of pairs of strings respectively enclosed in pipings peripherally disposed within said bag at different elevations in said bag, each of said pairs of strings being of different length from the other pairs and passing through openings at diametrically opposite sides of the bag, the strings within each pair being of substantially equal lengths and with all of said strings being attached at their ends to the respective masses and adapted to share the effort of lifting of said masses when said bag is inflated without a garment thereon.

4. A form as defined in claim 3 wherein the piping for an upper pair of said strings is located at an elevation on said bag which is above the lower edge of the garment and the piping for a lower pair of said strings is located at an elevation on said bag below said lower edge of the garment thereby to shift to the lower pair of strings the effort of lifting said masses and thereby to restrain the expansion of said bag below the lower edge of the garment.

5. A form as defined in claim 3 wherein said drawstring means comprises an upper, a central, and a lower pair of strings enclosed in corresponding pipings and with the central piping being located farther from the upper piping than from the lower piping.

6. A form for treating garments including a frame adapted to be supported at its lower end and having an annular lower wall, a generally vertical front member and a generally vertical rear member, said members being affixed at their lower ends to said wall, and a neck and shoulder element joining said members at their upper ends; an inflatable, gas-pervious bag supported at its upper end on said neck and shoulder element and affixed at its lower end to the periphery of said wall adjacent the top of said wall, a pair of masses of substantially equal weights suspended by a flexible drawstring means engaging an intermediate portion of said bag between its ends, the ends of said drawstring means being connected to the respective masses externally of said bag; an annular ring mounted for sliding movement vertically at the outer surface of said wall and disposed within said bag in sliding contact therewith, said ring being adapted to rise under the pull exerted by said bag as said bag expands under pressure of gases entering the same, and spring means mounted upon said frame and adapted to hold said ring at its lowermost position when said bag is deflated.

7. A form as defined in claim 6 including toggle means pivotally mounted at one end upon said frame and attached at the other end to said ring and at an intermediate point to said spring means, whereby as the ring rises under the pull of said bag, the opposition of said spring means to rising movement of said ring progressively decreases.

8. A garment finisher having an inflatable, fluid-pervious bag, a base assembly including means for directing steam and heated air into said bag, a frame mounted on said assembly and supporting said bag, a steam radiator in said base assembly, a valve for releasing steam from said radiator into said bag, a solenoid for controlling

said valve, a steam supply line and a steam return line connected to said radiator, a housing supporting a blower, a motor for driving said blower, an air duct for leading air under pressure from said blower to said base assembly, a damper in said duct, a shroud enclosing said housing and steam lines and having a rearwardly facing open end, a filter mounted in said shroud and through which filtered air passing to the blower is directed, a manually operable oscillatable and axially movable control shaft mounted on said housing and having handle means externally of said shroud, a mechanical connection from said shaft to said damper and adapted to close said damper when said shaft is rotated in one direction and to open the damper when the shaft is rotated in the opposite direction, said connection being enclosed by said shroud, and electrical circuit means including a switch for starting said motor when said shaft is rotated to its full extent in said one direction and a switch for energizing said solenoid when said shaft is shifted axially, said electrical circuit means being enclosed by said shroud.

9. Apparatus as defined in claim 8 wherein a separate handle is affixed to each end of said shaft and said shaft is adapted to close said solenoid switch when shifted axially in either direction.

10. In a garment finisher having an inflatable, gas-pervious bag, a base assembly including means for directing steam and air into said bag, a frame mounted upon said assembly and supporting said bag, a blower, a motor for driving said blower, an air duct for leading air under pressure from said blower to said base assembly, a damper in said duct, a steam radiator in said assembly for heating air passing into said bag, a valve for releasing steam from said radiator into said bag and controlled by a solenoid; the improvement comprising a manually and sequentially movable control means including an electrical circuit to said motor and to said solenoid and a mechanical connection to said damper, said control means during its initial movement to start said motor also moving said damper to substantially closed position by interaction with said mechanical connection and after said motor has started and prior to supplying steam to said bag being free to open said damper by means of said mechanical connection in order to size the bag to the garment with the air supplied from the activated blower, and thereafter by a subsequent movement without disturbing the damper setting being adapted to energize the solenoid.

11. Apparatus as defined in claim 10 wherein said electrical circuit includes an air timer, an air switch adapted to be closed during said initial movement of

said control means and serving to energize said air timer and said blower motor simultaneously, and a main relay adapted to close and to establish a holding circuit to said air timer and to said blower motor following reopening of said air switch during the sizing of the bag, and to interrupt the circuits for cancellation of the cycle upon reclosing of said air switch.

12. Apparatus as defined in claim 10 wherein said electrical circuit includes an air timer, an air switch adapted to be closed during said initial movement of said control means and serving to energize said air timer and said blower motor simultaneously, a steam timer, a steam switch adapted to be closed during said subsequent movement of said control means, a main relay adapted to close and to establish a holding circuit to said air timer and to said blower motor following reopening of said air switch during the sizing of the bag, a first steam relay adapted to close following the closing of said steam switch and to reopen following the deenergization of said steam timer, and a second steam relay adapted to open the holding circuit to said air timer and to said motor upon energization of said first steam relay and to reestablish the circuit to said air timer and to said motor upon deenergization of said first steam relay.

13. Apparatus as defined in claim 10 wherein said electrical circuit includes an air timer, an air switch adapted to be closed during said initial movement of said control means and serving to energize said air timer and said blower motor simultaneously, a steam timer, a steam switch adapted to be closed during said subsequent movement of said control means, a main relay adapted to close and to establish a holding circuit to said air timer and to said blower motor following reopening of said air switch during the sizing of the bag, a first steam relay adapted to close following the closing of said steam switch and to reopen following the reenergization of said steam timer, and a sequence switch movable between open and closed positions and when in said closed position establishing a shunt circuit to said air timer and to said blower motor during the energization of said steam timer.

References Cited

UNITED STATES PATENTS

2,533,761	12/1950	Brenner et al.	223—70
2,948,443	8/1960	Richterkessing et al.	223—67
3,006,516	10/1961	Richterkessing	223—70

JORDAN FRANKLIN, *Primary Examiner*.

GEORGE V. LARKIN, *Assistant Examiner*.