

J. DUTCHER.

Wagon-Brake.

No. 26,896.

Patented Jan. 24, 1860.

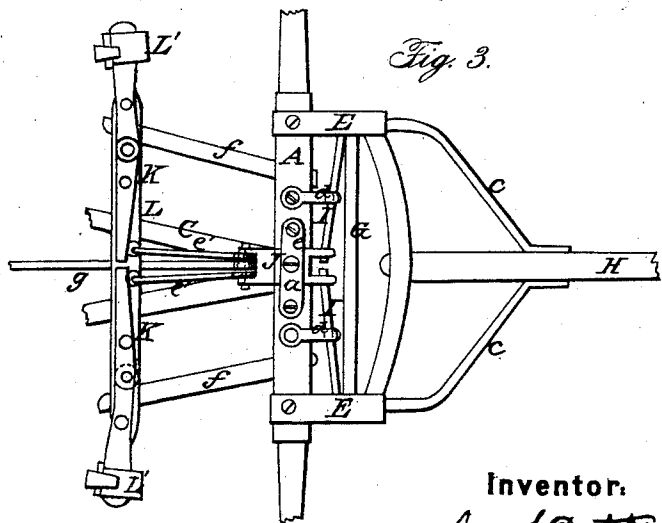
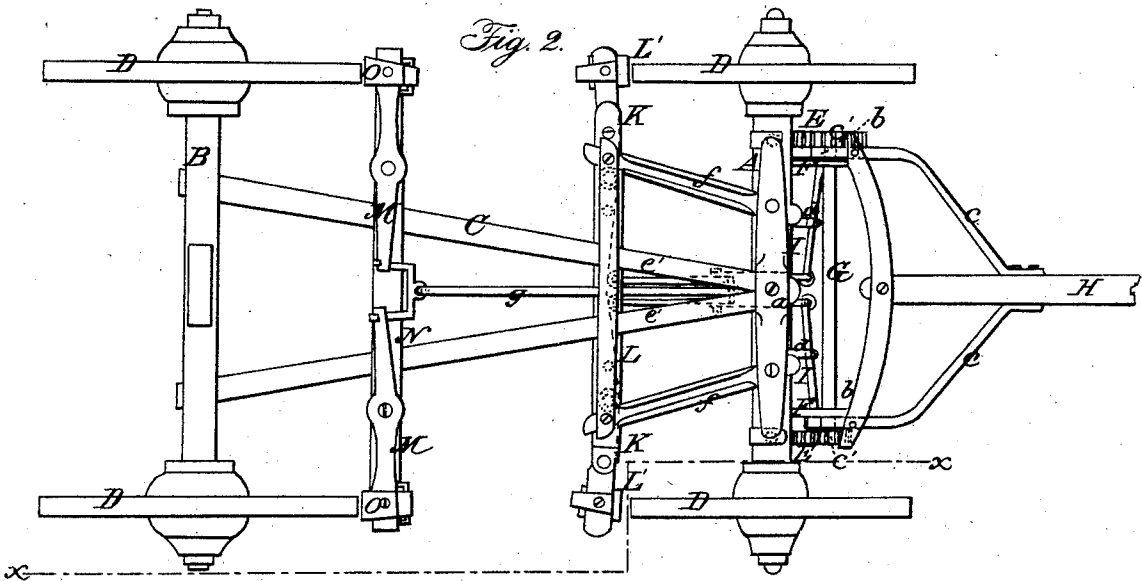
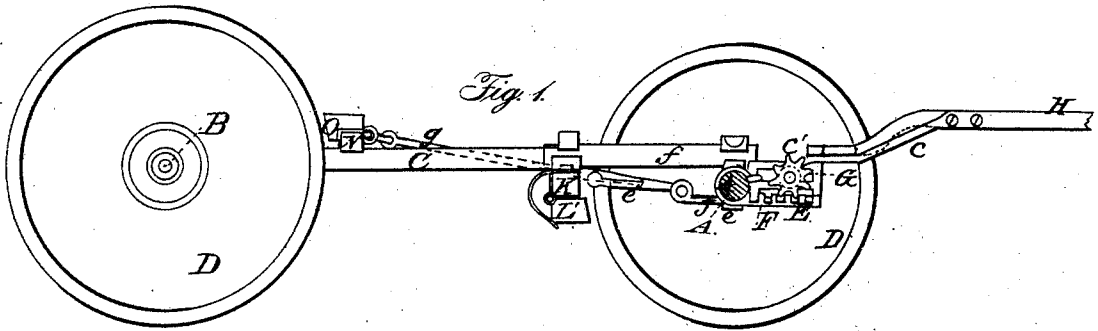

Witnesses:

J. S. Taylor
J. S. Taylor

Inventor:

Jacob Dutcher

UNITED STATES PATENT OFFICE.

JACOB DUTCHER, OF GIBSON, PENNSYLVANIA.

SELF-ACTING WAGON-BRAKE.

Specification of Letters Patent No. 26,896, dated January 24, 1860.

To all whom it may concern:

Be it known that I, JACOB DUTCHER, of Gibson, in the county of Susquehanna and State of Pennsylvania, have invented a new and Improved Wagon-Brake; and I do hereby declare that the following is a full, clear, and exact description of the same, reference being had to the annexed drawings, making a part of this specification, in which—

Figure 1, is a side sectional view of a vehicle with my invention applied to it, taken in the line x, x , Fig. 2, Fig. 2, a plan or top view of ditto, Fig. 3, an inverted plan of the front portion of ditto.

Similar letters of reference indicate corresponding parts in the several figures.

This invention relates to an improvement in that class of wagon brakes in which the brakes are connected with the draft pole and are generally termed "self acting."

The object of the within described invention is to obviate the difficulty hitherto caused by the binding of the draft pole in its guides, and the consequent imperfect action of the device.

To enable those skilled in the art to fully understand and construct my invention, I will proceed to describe it.

A, represents the front and B, the back axle of a vehicle. C, the reach which connects the two axles and D, the wheels. The front axle A, is attached to the front end of the reach C, by the usual king bolt a' .

To the front axle A, and near each end of it a rack E, is attached. These racks are parallel with each other and are attached to the axle A, at right angles, as shown clearly in Fig. 2. To the inner side of each rack E, a vertical plate F is attached.

These plates are slotted longitudinally, and form guides for a shaft G, which is fitted in bearings b , at the back ends of brace rods c, c , at the back part of the draft pole H. The shaft G, is allowed to turn freely in its bearings b , and at the same time is allowed to slide freely back and forth in its guides or slotted plates F, F. At each end of the shaft G, there is a pinion c' and these pinions gear into the racks E, E, as shown in Figs. 1 and 2.

To the back end of each brace rod c, c , and just below the bearings b , a lever I, is attached. These levers have their fulcra at d , and their inner ends are connected to a

slide J, which is fitted in a guide e , attached to the under side of the front axle, see Fig. 3.

To the back end of the slide J, two rods $e' e'$ are attached. These rods are attached to compound levers K, K, the fulcra of which are attached to a cross bar L, that is attached to arms f, f , projecting from the front axle and bolster. To the outer end of each lever K, a shoe L' , is attached, said shoes being directly back of the front wheels.

To the back end of the slide J, a rod g , is also attached. This rod g , extends back some distance, and is attached to the inner ends of two simple or single levers M, M, the fulcra of which are attached to a cross bar N, on the reach C. To the outer end of each lever M, a shoe O, is attached.

The shoes O, as well as the shoes L', L' , are so attached to their respective levers M, K, that they will yield or give to the action of the wheels when the latter are turning backward and therefore offer no impediment when the vehicle is backed.

From the above description it will be seen that when the speed of the team is checked or, when the wagon is descending prominences the wagon will move forward and the shoes will bear against the peripheries of the wheels precisely the same as other self-acting brakes of this class, but it will be also seen that the draft pole H, and wagon will be kept in line with each other in consequence of the pinions c' of shaft G, working in the racks E, E, and all binding and consequent friction attending the working of the back part of the draft pole in guides as hitherto will be avoided as the pinions c' insure an equal and simultaneous movement of each side of the inner part of the draft pole.

I do not claim the attaching of the shoe, bars or levers to the tongue or draft pole in order to obtain a self-acting brake for this is an old and well known device, but,

I do claim as new and desire to secure by Letters Patent,

The combination with the pole H, and axle A, of the racks E, E, and pinions c', c' , as and for the purpose herein shown and described.

JACOB DUTCHER.

Witnesses:

J. G. STILES,
JOEL S. TONGBY.