

(19)



Europäisches Patentamt

European Patent Office

Office européen des brevets



(11)

EP 0 955 241 A1

(12)

EUROPEAN PATENT APPLICATION

(43) Date of publication:

10.11.1999 Bulletin 1999/45

(51) Int Cl.⁶: **B65D 1/16, B65D 21/02**

(21) Application number: **99303099.8**

(22) Date of filing: **21.04.1999**

(84) Designated Contracting States:

**AT BE CH CY DE DK ES FI FR GB GR IE IT LI LU
MC NL PT SE**

Designated Extension States:

AL LT LV MK RO SI

(30) Priority: **05.05.1998 US 72929**

(71) Applicant: **Greif Bros. Corporation**

Delaware, OH 43015 (US)

(72) Inventors:

- **Malik, John H.**
Naperville, IL 60563 (US)
- **Lesko, Michael J.**
Bolingbrook, IL 60446 (US)

• **Karner, John**

Plainfield, IL 60544 (US)

• **Lencioni, Jeff**

St. Charles, IL 60175 (US)

• **Julien, Robert A.**

Naperville, IL 60563 (US)

• **Maslowski, Edward M.**

Burbank, IL 60459 (US)

(74) Representative:

MacDougall, Donald Carmichael et al

Cruikshank & Fairweather

19 Royal Exchange Square

Glasgow G1 3AE, Scotland (GB)

(54) **Nestable high-strength molded plastic drum**

(57) A molded plastic drum (10) for shipping large quantities of food or other materials includes cylindrical or frustoconical upper (18) and lower (20) sections joined by a middle transition section (22) that is frustoconically shaped. The lower section is smaller in diameter than the upper section to permit nesting of the drums. The lower section side wall includes reinforcing flutes (48) for stiffening the lower section to prevent elephant footing. A chime (24) is compression-molded onto the upper edge of the drum body such that no portion of the chime extends inwardly and there are no depres-

sions in the inner surface of the side wall, thus permitting solid or semi-solid materials to slide unimpeded out the top opening of the drum. A clearance ring (46) is compression-molded onto the side wall of the drum at a location spaced below the chime to help prevent the cover of the drum from being dislodged by contact with an adjacent drum or a wall of a shipping container. The drum side wall preferably comprises a laminate having a layer of polymer containing a reinforcing agent such as glass fibers, and two layers of high-density polyethylene sandwiching the reinforced polymer layer therebetween.

EP 0 955 241 A1

Description

Field of the Invention

[0001] The present invention relates to drums for shipping and storing large quantities of food or other materials.

Background of the Invention

[0002] Large quantities of food products or other materials are frequently shipped and stored in drums having a capacity of up to about 500 pounds each. Drums of this capacity are usually made of steel because of the need to withstand substantial material stresses generated by static and dynamic loads placed on the drums as the drums are moved about and sometimes stacked one upon another. Steel drums provide adequate stack strength over a wide range of temperatures, and are also rugged enough to be reusable after reconditioning.

[0003] However, steel drums dent easily during handling and the dents interfere with nesting of the drums. Thus, once they are emptied, steel drums are typically shipped back in non-nested condition. This lack of ability to nest leads to increased costs for return shipping. Furthermore, steel drums are relatively heavy, increasing the cost of shipping in both the outgoing and return directions. Moreover, reconditioning costs for steel drums are relatively high.

[0004] A further problem with steel drums is that they tend to rust when not in active use. This is particularly troublesome when food is being contained, because the rusted surface represents a contaminant and can also harbor bacteria or other contaminants, thus hampering compliance with regulatory cleanliness and purity requirements.

[0005] Because of these and other disadvantages of steel drums, plastic drums have been developed. Plastic drums can be made lighter so that shipping costs are reduced. Further, plastic drums do not rust and are therefore particularly suitable for containing food or other materials in which purity and cleanliness are important. Plastic drums also tend not to dent, and hence are more amenable to nesting than steel drums.

[0006] However, plastic drums are more prone than steel drums to being deformed by static and dynamic loads. Especially when plastic drums are filled and left standing for long periods of time, and/or are stacked one upon another, they can be susceptible to "elephant footing" in which the bottom ends of the drums are deformed radially outwardly. Elephant footing can interfere with the ability to nest the drums. It is also technically challenging to provide a plastic drum cover having adequate strength for supporting the weight of another filled drum stacked atop the cover and having adequate stiffness to retain its shape and its sealed connection to the drum even when subjected to jostling during shipping and handling.

[0007] A further problem associated particularly with blow-molded plastic drums is that molding the chime at the upper edge of the drum for engaging a removable cover frequently results in a groove or protuberance on the inner surface of the drum. Such grooves or protuberances can impede sliding solid or semi-solid materials out the open top end of the drum.

[0008] Yet another problem associated with both steel and plastic drums having removable covers is that the covers can be inadvertently dislodged by contact with adjacent drums or with a wall of a shipping container as the drums shift position during transit.

Summary of the Invention

[0009] The present invention overcomes the disadvantages of prior drums noted above, by providing a plastic drum having a configuration permitting nesting of the drums, having adequate strength to permit stacking of filled drums and to substantially avoid elephant footing or other deformations, having features that reduce the likelihood of a cover being inadvertently dislodged by an adjacent drum or wall, and having a chime construction that does not impede removal of materials from the drum.

[0010] More particularly, the invention provides a drum having a drum body formed generally as a body of revolution. The drum body preferably includes a substantially straight-walled upper section and a substantially straight-walled lower section, with a frustoconical section joining the upper section to the lower section. The maximum outer diameter of the lower section is not greater than the minimum inner diameter of the upper section such that the drum can be nested into a second drum of the same configuration. An external chime is formed, preferably by compression molding, on the side wall of the drum body at the upper edge thereof such that the inner surface of the side wall is free of depressions and protuberances.

[0011] The drum also includes a clearance ring on the outer surface of the upper section of the drum spaced below the chime. The clearance ring extends outwardly for a sufficient radial extent to protect a cover of the drum from interference by an adjacent drum. The clearance ring also can be gripped by a fork lift or other lifting device for picking up the drum.

[0012] The upper and lower sections may each be cylindrical or frustoconical. Preferably, the frustoconical transition section is sized to rest on the upper edge of the drum body of a second drum when the drum is nested into the second drum, and the drum body is configured such that in the nested condition there is clearance between the outer surface of the lower section and the inner surface of the second drum. Thus, the drums may be nested without becoming locked together by vacuum.

[0013] For resisting deformation of the drum, and particularly of the lower portion of the drum where elephant

footing can interfere with nestability, the drum preferably includes reinforcing flutes in the lower section of the drum adjacent the bottom wall of the drum. The reinforcing flutes preferably have a smoothly curving wavy configuration such that there are no sharp corners where contaminants would be difficult to remove, thus facilitating cleaning of the drum.

[0014] In accordance with a preferred construction of the drum for achieving still greater strength, the drum side wall is formed of a laminate which includes a layer of polymer material containing a reinforcing agent, and two outer layers of non-reinforced thermoplastic, preferably high-density polyethylene (HDPE), sandwiching the reinforced polymer layer therebetween. The laminated side wall provides substantially greater strength than a solid wall of non-reinforced thermoplastic having the same thickness. At the same time, the non-reinforced thermoplastic layers form a barrier preventing exposure to the reinforced polymer layer, and thus the laminated side wall can be used for containing foods and other materials where contamination of the contents by the reinforcing agent must be prevented.

[0015] The drum preferably also includes a cover configured for adequate strength and stiffness to enable stacking of filled drums one upon another and to resist deformation of the cover by internal pressure in the drum and other loads encountered during shipping and storage. Specifically, the cover comprises a circular panel and a rim formed on the periphery of the circular panel. The circular panel includes undulations for stiffening the cover. The undulations preferably radiate out from the center of the circular panel and are configured such that the upper and lower surfaces of the circular panel are substantially flat in the radial direction and are undulating in the circumferential direction. The undulations provide increased stiffness and resistance to bowing of the cover.

[0016] The cover preferably also includes a circular recess defined by the rim which extends upwardly from the periphery of the circular panel. To facilitate stacking of drums, the bottom wall of the drum and the recess are sized such that the bottom of one drum fits within the recess and rests upon the circular panel of the cover of another drum.

[0017] The bottom wall of the drum also includes features giving the bottom increased strength. Specifically, the bottom wall is waffled to stiffen the wall. The bottom wall preferably also includes a pushed-up portion that extends along a diameter of the bottom wall so as to form a stiffening beam.

[0018] The invention thus provides an improved nestable plastic drum which has sufficient strength and stiffness for use as a large-capacity drum holding up to about 500 pounds of contents and which retains its nestable shape. The invention further provides a drum with an entirely external top chime to eliminate impediments to solid materials being slid out the open top of the drum, and with a clearance ring serving both as a

standoff protecting the cover from being interfered with and dislodged and as a lifting surface.

Brief Description of the Drawings

[0019] The above and other objects, features, and advantages of the invention will become more apparent from the following description of a preferred embodiment thereof when taken in conjunction with the accompanying drawings in which:

FIG. 1 is a perspective view of a preferred embodiment of a drum in accordance with the invention; FIG. 2 is a cross-sectional view taken on line 2-2 of FIG. 1;

FIG. 3 is a cross-sectional view taken on a vertical plane through the upper edge of the drum and cover, depicting details of the chime and rim of the cover;

FIG. 4 is a cross-sectional view taken on line 4-4 of FIG. 1, showing the undulations of the cover in greater detail;

FIG. 5 is a cross-sectional view taken on line 5-5 of FIG. 1, showing the reinforcing flutes of the drum body in greater detail;

FIG. 6 is a bottom plan view of the bottom wall of the drum;

FIG. 7 is a cross-sectional view taken on line 7-7 of FIG. 6;

FIG. 8 is a cross-sectional view showing a laminated side wall of a drum in accordance with the invention; and

FIG. 9 is a cross-sectional view similar to FIG. 2, but showing several drums nested together.

Detailed Description of the Drawings

[0020] With reference to the Figures, a drum in accordance with the invention is broadly designated by the reference numeral **10**. The drum **10** includes a drum body **12**, a bottom wall **14**, and a cover **16**. The drum body **12** is preferably formed generally as a body of revolution, except for certain features as described below.

[0021] The drum body **12** and bottom wall **14** are configured so as to permit nesting of the drum **10** into another one of the drums. Thus, the drum body **12** is formed of three sections, namely, an upper section **18**, a lower section **20**, and a frustoconical transition section **22** which joins the upper section **18** to the lower section **20**. The upper and lower sections **18** and **20** are each substantially straight walled, i.e., cylindrical or frustoconical. In the embodiment of the invention depicted in the Figures, the upper section **18** is substantially cylindrical and the lower section **20** is substantially frustoconical. The lower section **20** and the bottom wall **14** are smaller in outer diameter than the inner diameter of the upper section **18**. Accordingly, as shown in FIG. 9, the drum **10** may be nested into another drum **10**. To facili-

tate nesting, the frustoconical transition section **22** advantageously is located about halfway up the height of the drum body **12**.

[0022] The transition section **22** is sized in relation to the inner diameter of the upper edge **23** of the drum body such that the transition section **22** of one drum **10** rests on the upper edge **23** of another drum **10** into which the drum is nested, as shown in FIG. 9. The lower section **20** of the drum is configured such that when the drum is nested into a second drum there is clearance between the outer surface of the lower section **20** and the inner surface of the second drum. Therefore, the nested drums tend not to become locked together by vacuum.

[0023] The drum **10** includes a chime **24** at the upper edge **23** of the drum body **12** for engagement by the cover **16** to sealingly retain the cover on the drum. As best seen in FIG. 3, the chime **24** is entirely external to the drum such that there are no protuberances which extend inwardly into the top opening **26** (FIG. 1) and there are no depressions in the inner surface **28** of the drum body **12**. Thus, solid or semi-solid materials can be slid out the top opening of the drum without hindrance. Advantageously, the chime **24** is compression molded onto the side wall of the drum body **12**.

[0024] The cover **16** includes a circular panel **30** and a rim **32** which extends upwardly and outwardly from the periphery of the circular panel **30** so as to define a circular recess **34** in the cover. The rim **32** is configured to cooperate with the chime **24** to effect a seal between the cover **16** and the drum body **12**. The rim **32** includes an upstanding cylindrical section **36** which extends upward from the outer periphery of the circular panel **30**, a stepped annular flange **38** which extends radially outward from the upper edge of the cylindrical section **36**, and a skirt **40** depending from the outer edge of the annular flange **38**. Although not shown, a lockband typically is encircled and clamped about the rim **32** and chime **24** after the cover **16** is applied to the top of the drum so as to lock the cover in place.

[0025] The cover **16** includes undulations **42** formed in the circular panel **30** for stiffening the cover. The undulations **42** radiate out from the center of the circular panel **30**. Preferably, the undulations are formed such that the upper and lower surfaces of the circular panel **30** are substantially flat in the radial direction but undulating in the circumferential direction. That is, the surfaces of the circular panel **30** each are described by a radial line having one end fixed at the center of the panel **30** and the other end located at the cylindrical section **36** of the rim, the line being rotated about the center and pivoted up and down such that the outer end of the line circumscribes a circumferentially extending waveform such as a sine wave. Thus, the amplitude of the wave varies in proportion to the radial distance from the center of the circular panel **30**. The cover **16** depicted in the Figures has undulations **42** of non-varying wavelength and amplitude in the circumferential direction, but in some applications it may be desired to employ undula-

tions having varying wavelength and/or amplitude in the circumferential direction.

[0026] To facilitate stacking one drum **10** on another drum **10**, the bottom wall **14** of the drum **10** includes a foot **44** whose outer diameter is not greater than the outer diameter of the circular panel **30** of the cover **16**. The bottom of one drum is thus supported by the circular panel **30** of the cover of the other drum.

[0027] The drum **10** also includes a clearance ring **46** formed on the outer surface of the upper section **18** of the drum body **12** and spaced below the chime **24**. The clearance ring **46** extends radially outward a sufficient distance to act as a standoff for protecting the cover **16** and lockband (not shown) of the drum from being interfered with by an adjacent drum or by a wall of a shipping container in which the drum is contained during shipping. Such interference can force the cover off the drum during transit even if the drums are tightly loaded so that they cannot readily move about. Additionally, the clearance ring **46** and lockband cooperate to form two points of contact with adjacent drums or the shipping container wall, thus making the drum more stable and less prone to tipping. The clearance ring **46** also serves as a lifting surface which can be gripped by a fork lift or other lifting device. Preferably, the clearance ring **46** is compression molded into the side wall of the drum body **12** so that there are no protuberances or grooves in the inner surface of the drum body in the vicinity of the clearance ring.

[0028] The drum **10** also includes features for strengthening the drum body **12** to prevent deformation such as "elephant footing" which can hamper the ability of the drum to nest. More particularly, the lower section **20** of the drum body **12** has reinforcing flutes **48**, as best seen in FIG. 5, which increase the moment of inertia of the drum body adjacent the bottom wall **14**. Preferably, the flutes **48** are smoothly curved such that there are no sharp corners or crevices from which contaminants would be difficult to remove, thus facilitating cleaning of the drum. The flutes **48** advantageously are angularly spaced apart by an angle α of about 6°.

[0029] The bottom wall **14** also includes stiffening features. Specifically, with reference to FIGS. 6 and 7, the bottom wall **14** is waffled by forming a grid of intersecting downwardly depressed troughs **50** therein. The bottom wall also has a pushed-up portion **52** which extends along a diameter of the bottom wall so as to form a stiffening beam. The waffle pattern and stiffening beam serve to increase the bending stiffness of the bottom wall **14** to resist bowing thereof.

[0030] For achieving still greater strength of the drum and resistance to deformation, it is advantageous to form the side wall of the drum body from a laminate as shown in FIG. 8. The laminate **54** comprises a middle layer **56** of polymer reinforced with a reinforcing agent, and outer layers **58** of non-reinforced polymer. Preferably, the three layers comprise thermoplastic materials. More preferably, the outer layers **58** comprise polyethylene, and most preferably high-density polyethylene

which provides excellent chemical resistance and can be manufactured to meet all applicable FDA regulations for use in food containers. The reinforced layer 56 preferably comprises polyethylene containing glass fibers, mica, and/or talc as reinforcing agents. The laminated construction of the drum body side wall provides high strength while preventing contents of the drum or persons handling the drum from being exposed to the reinforcing agents.

[0031] From the foregoing description of a preferred embodiment of the invention, it will be appreciated that the invention provides a unique molded plastic drum configuration having high strength and resistance to deformation even when subjected to loads for extended periods of time, thus enabling the drum to be configured to be nestable and to retain the nestable shape through repeated uses. The invention achieves a high-strength drum by the incorporation of reinforcing flutes in the body side wall adjacent the bottom wall of the drum, by providing undulations in the cover, and by configuring the bottom wall of the drum with a waffle pattern and stiffening beam. Additionally, the drum body may be formed of a reinforced laminate to provide still greater strength and resistance to deformation.

[0032] The invention also provides a drum having a unique external chime and a clearance ring which are formed on the side wall such that there are no depressions or protuberances on the inner surface of the side wall in the vicinity of the chime and clearance ring, thus facilitating sliding a solid or semi-solid material out the open top of the drum without hindrance. The clearance ring serves both as a standoff preventing adjacent drums from riding up on and dislodging the cover and lockband of the drum, and as a lifting surface for the drum.

[0033] While the invention has been explained by describing a preferred embodiment thereof in considerable detail, it is to be understood that the invention is not limited to the details which have been illustrated and described, and modifications and substitutions of equivalents may be made without departing from the scope of the claims as set forth in the appended claims.

Claims

1. A molded plastic drum, comprising:
 a bottom wall;
 a drum body defined by a side wall extending upwardly from the bottom wall and having inner and outer surfaces and an upper edge defining a top opening of the drum, a portion of the side wall adjacent the bottom wall having reinforcing flutes for strengthening the side wall and preventing permanent radial expansion thereof, the side wall being constructed of a laminate having a layer of polymer reinforced with a re-

inforcing agent and two outer non-reinforced polymer layers sandwiching the reinforced polymer layer therebetween; and
 a chime molded into the side wall at the upper edge of the drum body such that no portion of the chime extends inwardly of the inner surface of the side wall.

2. The molded plastic drum of claim 1, wherein the drum body includes a substantially straight-walled upper section, a substantially straight-walled lower section, and a frustoconical transition section between the upper and lower sections, the lower section having a maximum outer diameter not greater than the minimum inner diameter of the upper section so as to permit nesting the drum into a second drum.
3. The molded plastic drum of claim 2, further comprising a circumferential clearance ring extending outwardly from the outer surface of the drum body and spaced below the chime, the clearance ring having a radial extent sufficient to protect a cover of the drum from interference by an adjacent one of the drums.
4. The molded plastic drum of claim 3, wherein the chime and the clearance ring comprise compression-molded members molded into the side wall such that the inner surface of the side wall in the vicinity of the chime and clearance ring is free of depressions and protuberances.
5. The molded plastic drum of claim 2, wherein the upper section is cylindrical and the lower section is frustoconical.
6. The molded plastic drum of claim 2, wherein the frustoconical transition section is sized to rest on the upper edge of the drum body of a second drum when the drum is nested into the second drum, and wherein the drum body is configured such that in the nested condition there is clearance between the outer surface of the lower section and the inner surface of the second drum.
7. The molded plastic drum of claim 1, wherein the reinforcing agent comprises at least one of glass fibers, mica, and talc.
8. The molded plastic drum of claim 1, wherein the non-reinforced polymer layers comprise high-density polyethylene.
9. The molded plastic drum of claim 1, further comprising a cover which includes a circular panel and a rim formed on the periphery of the circular panel for engaging the top opening and chime of the drum,

and wherein the circular panel is formed to have undulations for stiffening the cover.

- 10. The molded plastic drum of claim 9, wherein the undulations radiate out from the center of the circular panel and are formed such that the upper and lower surfaces of the circular panel are substantially flat in the radial direction and are undulating in the circumferential direction. 5
10
- 11. The molded plastic drum of claim 9, wherein the rim extends upward from the periphery of the circular panel so as to define a circular recess in the cover, and wherein the bottom wall of the drum has a maximum outer diameter smaller than the diameter of the circular recess to permit the drum to be stacked atop the cover of another drum. 15
- 12. The molded plastic drum of claim 1, wherein the bottom wall comprises a waffled construction to increase the stiffness thereof. 20
- 13. The molded plastic drum of claim 12, wherein the bottom wall is circular and further includes a pushed-up portion extending along a diameter of the bottom wall so as to form a stiffening beam. 25

30

35

40

45

50

55

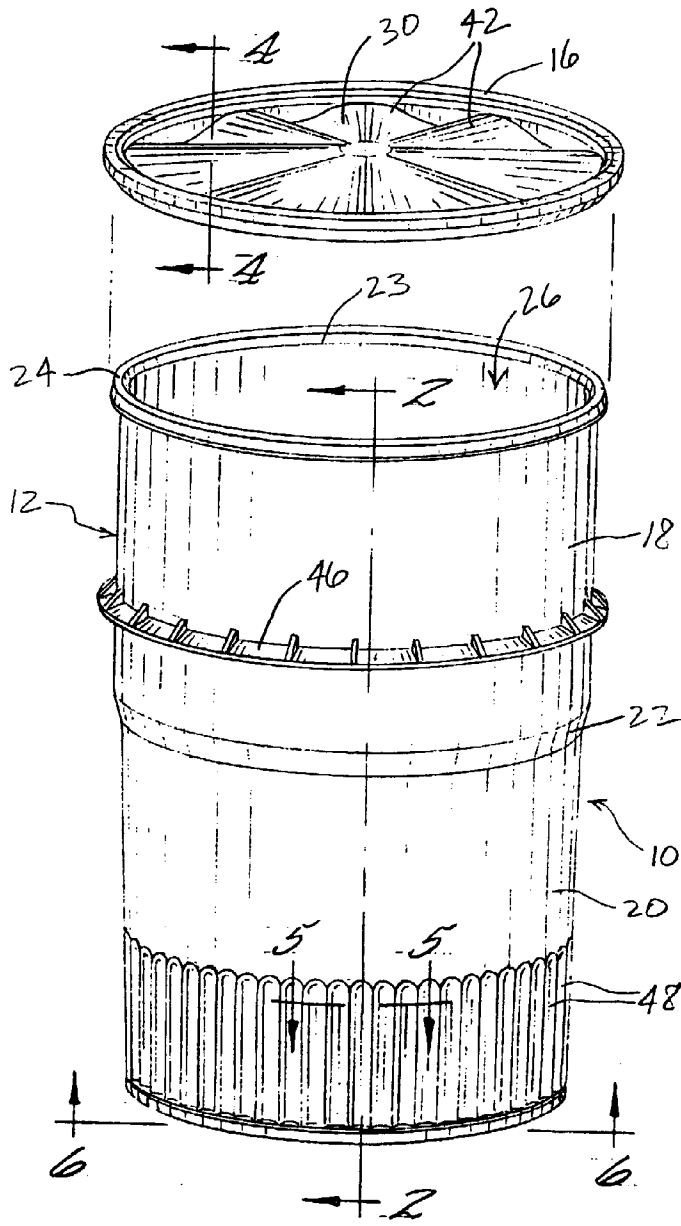

FIG. 1.

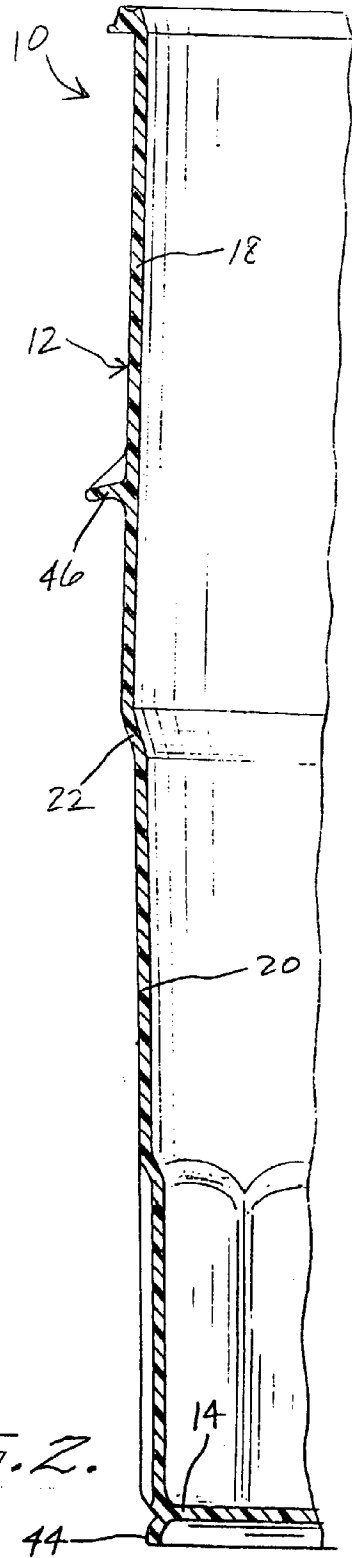

FIG. 2.

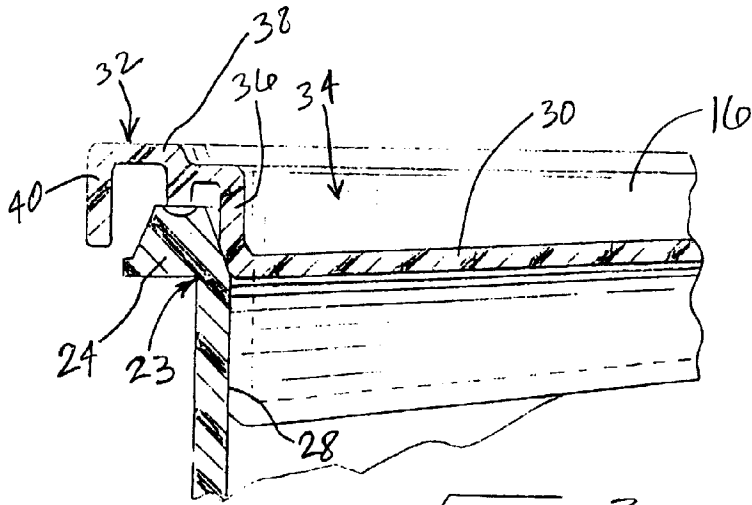

FIG. 3.

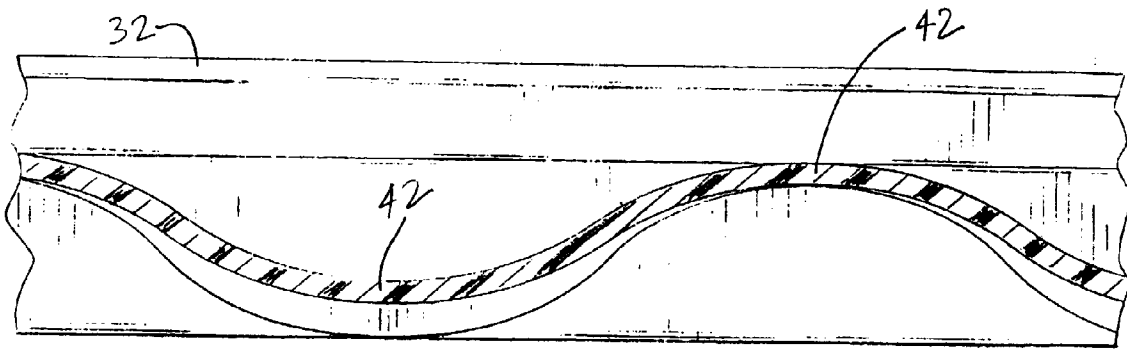

FIG. 4.

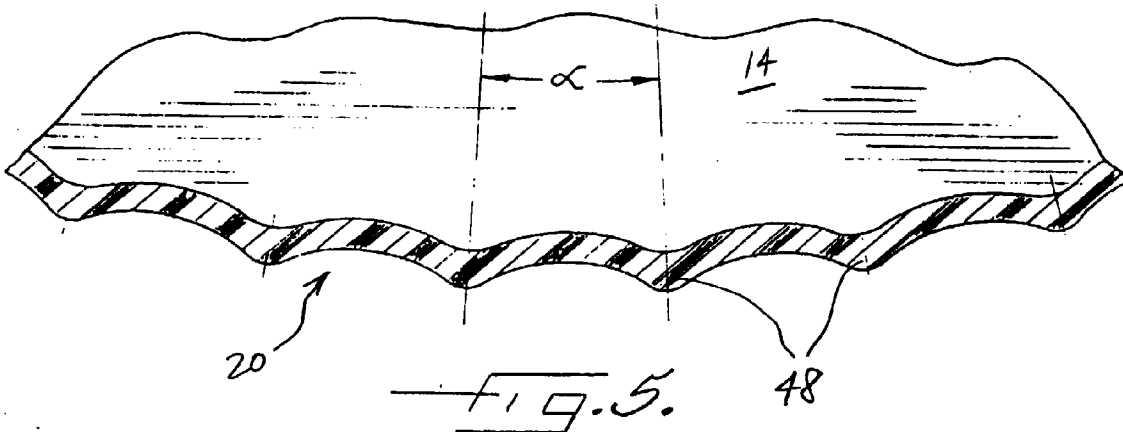

FIG. 5.

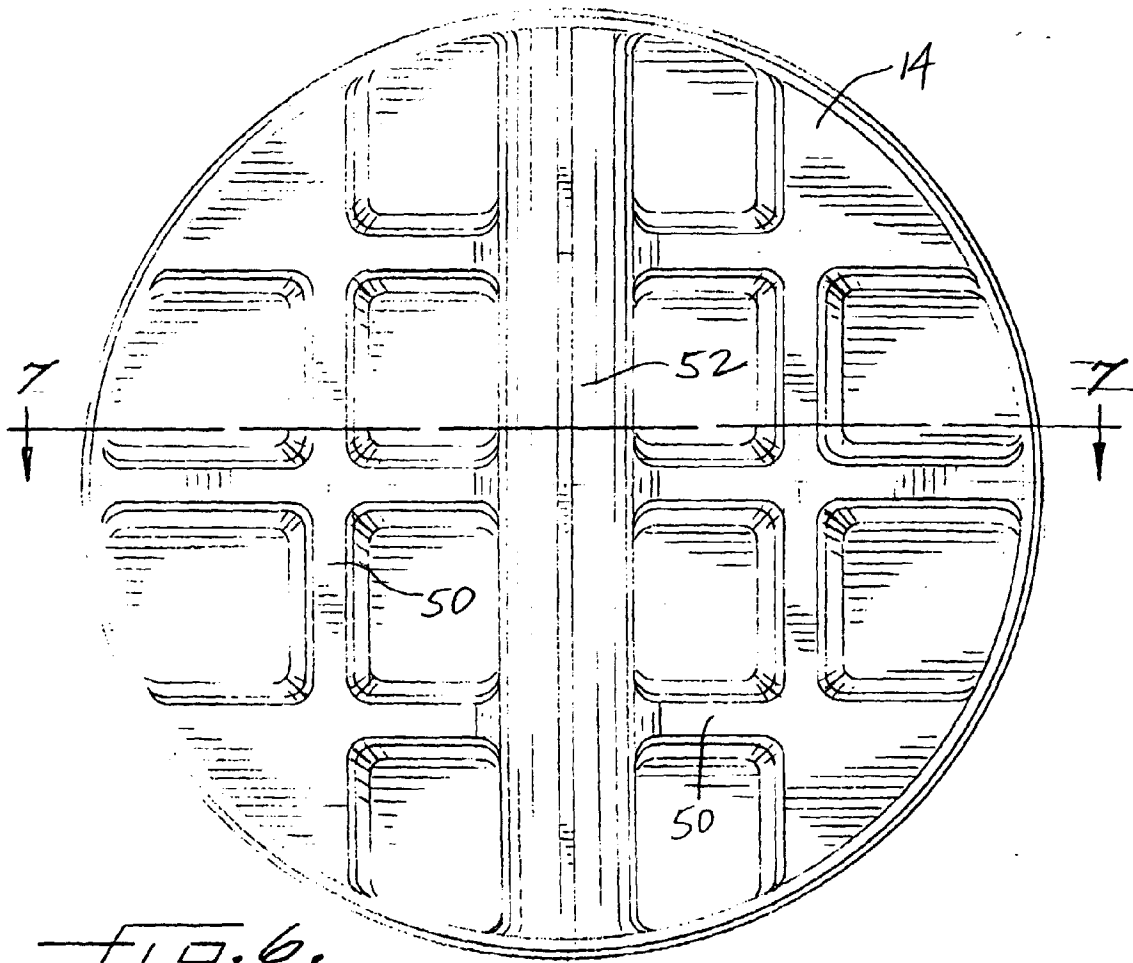

FIG. 6.

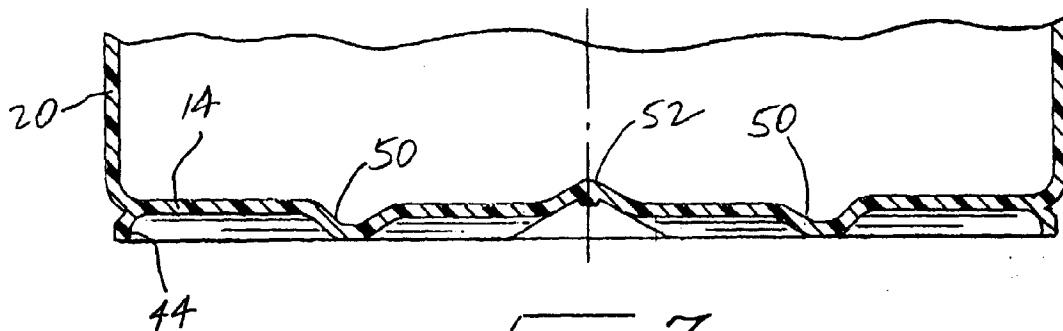

FIG. 7.



European Patent
Office

EUROPEAN SEARCH REPORT

Application Number
EP 99 30 3099

DOCUMENTS CONSIDERED TO BE RELEVANT			
Category	Citation of document with indication, where appropriate, of relevant passages	Relevant to claim	CLASSIFICATION OF THE APPLICATION (Int.Cl.6)
A	EP 0 279 607 A (ESSEX ENVIRONMENTAL IND INC) 24 August 1988 (1988-08-24) * the whole document * ---	1,2,6, 8-13	B65D1/16 B65D21/02
A	US 5 607 075 A (BURGDORF MAERTEN ET AL) 4 March 1997 (1997-03-04) * column 2, line 8 - column 3, line 30; figures * ---	1,3,9,11	
A	US 4 708 258 A (SHAW MARK D ET AL) 24 November 1987 (1987-11-24) * abstract; figures * -----	1	
			TECHNICAL FIELDS SEARCHED (Int.Cl.6)
			B65D
The present search report has been drawn up for all claims			
Place of search	Date of completion of the search	Examiner	
THE HAGUE	7 September 1999	SERRANO GALARRAGA, J	
CATEGORY OF CITED DOCUMENTS		T : theory or principle underlying the invention E : earlier patent document, but published on, or after the filing date D : document cited in the application L : document cited for other reasons & : member of the same patent family, corresponding document	
X : particularly relevant if taken alone Y : particularly relevant if combined with another document of the same category A : technological background O : non-written disclosure P : intermediate document			

EPO FORM 1503 03 82 (Pst/C01)

**ANNEX TO THE EUROPEAN SEARCH REPORT
ON EUROPEAN PATENT APPLICATION NO.**

EP 99 30 3099

This annex lists the patent family members relating to the patent documents cited in the above-mentioned European search report. The members are as contained in the European Patent Office EDP file on
The European Patent Office is in no way liable for these particulars which are merely given for the purpose of information.

07-09-1999

Patent document cited in search report		Publication date	Patent family member(s)	Publication date
EP 0279607	A	24-08-1988	US 4709833	A 01-12-1987
			AU 1175688	A 25-08-1988
			CA 1301090	A 19-05-1992
			JP 1213149	A 25-08-1989

US 5607075	A	04-03-1997	DE 9106443	U 02-07-1992
			AT 126157	T 15-08-1995
			AU 662329	B 31-08-1995
			AU 1693692	A 08-01-1993
			BR 9206056	A 08-11-1994
			CA 2109949	A 10-12-1992
			CN 1067219	A 23-12-1992
			DE 59203241	D 14-09-1995
			DK 585290	T 27-12-1995
			WO 9221576	A 10-12-1992
			EP 0585290	A 09-03-1994
			ES 2076763	T 01-11-1995
			GR 3017929	T 31-01-1996
			JP 6507594	T 01-09-1994
NO 304420	B 14-12-1998			

US 4708258	A	24-11-1987	DE 3732975	A 15-09-1988
