



(51) International Patent Classification:

C02F 1/467 (2006.01) C02F 1/68 (2006.01)
B01F 23/43 (2022.01) B01F 23/70 (2022.01)
B01F 33/25 (2022.01) C02F 103/02 (2006.01)
B01F 33/45 (2022.01)

(21) International Application Number:

PCT/EP2022/063639

(22) International Filing Date:

19 May 2022 (19.05.2022)

(25) Filing Language:

English

(26) Publication Language:

English

(30) Priority Data:

00569/21 20 May 2021 (20.05.2021) CH

(71) Applicant: SWISS NEWATER HOLDING SÀRL

[CH/CH]; Rue du Centre 20, 1009 Pully (CH).

(72) Inventor: MEEUWISSE, René; Gerben van Manenstraat

110, 9204LP Drachten (NL).

(74) Agent: RENTSCH PARTNER AG; Kirchenweg 8, Post-

fach, 8034 Zürich (CH).

(81) Designated States (unless otherwise indicated, for every

kind of national protection available): AE, AG, AL, AM, AO, AT, AU, AZ, BA, BB, BG, BH, BN, BR, BW, BY, BZ, CA, CH, CL, CN, CO, CR, CU, CZ, DE, DJ, DK, DM, DO, DZ, EC, EE, EG, ES, FI, GB, GD, GE, GH, GM, GT, HN, HR, HU, ID, IL, IN, IQ, IR, IS, IT, JM, JO, JP, KE, KG, KH, KN, KP, KR, KW, KZ, LA, LC, LK, LR, LS, LU, LY, MA, MD, ME, MG, MK, MN, MW, MX, MY, MZ, NA, NG, NI, NO, NZ, OM, PA, PE, PG, PH, PL, PT, QA, RO, RS, RU, RW, SA, SC, SD, SE, SG, SK, SL, ST, SV, SY, TH, TJ, TM,

(54) Title: AN APPARATUS, A SYSTEM AND A METHOD FOR MANUFACTURING DISINFECTING AND CLEANING COMPOSITIONS

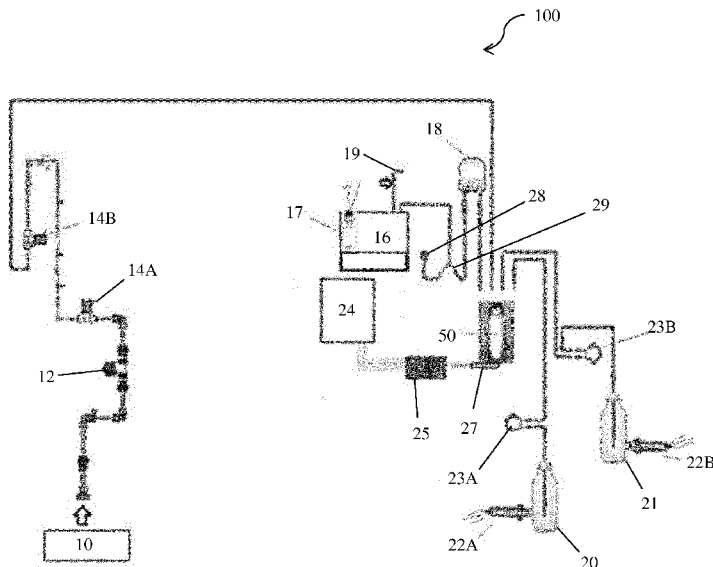

Figure 1

(57) Abstract: The present invention relates to apparatuses, systems and methods for manufacturing disinfecting and cleaning compositions. The apparatus, of the present disclosure, comprises an electrolyzed water storage tank for storing electrolyzed water, and configured to be in fluid communication with an electrolyzer, a fresh water tank, at least one additive carrying container containing an additive, and optionally a brine tank for supplying controlled quantities of brine to said receiving container. The apparatus further comprises conduits connecting the electrolyzed water storage tank, the fresh water tank, said additive carrying container and brine (if any) to at least one receiving container, and means for dispensing controlled amounts of the electrolysed water, fresh water, brine (if any) and the additives into said receiving container to obtain a disinfecting and cleaning solution.



TN, TR, TT, TZ, UA, UG, US, UZ, VC, VN, WS, ZA, ZM, ZW.

- (84) Designated States** (*unless otherwise indicated, for every kind of regional protection available*): ARIPO (BW, GH, GM, KE, LR, LS, MW, MZ, NA, RW, SD, SL, ST, SZ, TZ, UG, ZM, ZW), Eurasian (AM, AZ, BY, KG, KZ, RU, TJ, TM), European (AL, AT, BE, BG, CH, CY, CZ, DE, DK, EE, ES, FI, FR, GB, GR, HR, HU, IE, IS, IT, LT, LU, LV, MC, MK, MT, NL, NO, PL, PT, RO, RS, SE, SI, SK, SM, TR), OAPI (BF, BJ, CF, CG, CI, CM, GA, GN, GQ, GW, KM, ML, MR, NE, SN, TD, TG).

Published:

- *with international search report (Art. 21(3))*

AN APPARATUS, A SYSTEM AND A METHOD FOR MANUFACTURING DISINFECTING AND CLEANING COMPOSITIONS

FIELD OF THE INVENTION

[0001] The present invention relates to apparatuses, systems and methods for manufacturing disinfecting and cleaning compositions.

DEFINITION

[0002] **Fresh Water:** The term 'fresh water' used in this specification is meant to mean water which does not contain significant amount of micro-organisms and has a low TDS factor below 100 ppm and a hardness below 100 ppm.

BACKGROUND

[0003] Systems for producing disinfecting and cleaning compositions, typically are configured to produce a batch of solutions having a predetermined quantity of the solution and the dilutant. A fixed amount of additive(s) is then added to the prepared batch of cleaning solution. As a result, the conventional systems have a limited application and cannot be used for making cleaning solutions having different concentration of ingredients and catering to various applications. As a result, a different system is required for preparing a different type of solution. Further, the conventional systems require an operator to continuously monitor and control the systems, and dispense the required amount of solution into a container.

[0004] There is therefore felt a need of an apparatus, a system and a method for manufacturing a variety of disinfecting and cleaning compositions having different constituents and ingredients within the same system and apparatus, and which alleviate the aforementioned drawbacks.

OBJECTS

[0005] Some of the objects of the present disclosure, which at least one embodiment herein satisfies, are as follows:

[0006] An object of the present disclosure is to provide an apparatus and a system for manufacturing disinfecting and cleaning compositions.

[0007] Another object of the present disclosure is to provide an apparatus and a system for manufacturing a variety of disinfecting and cleaning compositions having different constituents and ingredients within the same system and apparatus

[0008] Yet another object of the present disclosure is to provide an apparatus and a system for manufacturing disinfecting and cleaning compositions, which can be customized to produce different concentrations and quantities disinfecting and cleaning compositions.

[0009] Still another object of the present disclosure is to provide an apparatus and a system for manufacturing disinfecting and cleaning compositions, which can automatically dispense the disinfecting and cleaning compositions.

[0010] Another object of the present disclosure is to provide an apparatus and a system for manufacturing disinfecting and cleaning compositions, which can be remotely controlled.

[0011] Other objects and advantages of the present disclosure will be more apparent from the following description, which is not intended to limit the scope of the present disclosure.

SUMMARY

[0012] The present disclosure envisages an apparatus for manufacturing disinfecting and cleaning compositions. The apparatus comprises an electrolyzed water storage tank, a fresh water tank, and at least one additive carrying container. The electrolyzed water storage tank is configured to be in fluid communication with an electrolyzer. The electrolyzed water storage tank is configured to store electrolyzed water. The additive carrying container contains an additive(s). The apparatus optionally includes a brine tank for storing brine. Conduits connect the electrolyzed water storage tank, the fresh water tank, the additive carrying container(s) and the brine tank (if provided) to at least one receiving container for receiving therein electrolysed water, fresh water, brine (if any) and the additive(s). The apparatus further comprises means for supplying controlled amounts electrolysed water, controlled amounts of fresh water, controlled amounts of brine (if any), and controlled amounts of additive(s) into the receiving container to obtain a disinfecting and cleaning solution.

[0013] In one embodiment, a gas vent is provided on the electrolysed water storage tank to vent out potentially hazardous gases that may collect in the storage tank.

[0014] In an embodiment, the apparatus includes a plurality of first sensors connected between the means for supplying electrolysed water, means for supplying fresh water, means

for supplying brine (if any), and means for supplying additive(s) and an inlet (not specifically marked in the drawing) of the receiving container. The first sensors are configured to obtain a feedback of electrolysed water, fresh water, the additive(s) and brine (if any) being supplied into the receiving container.

[0015] In another embodiment, the apparatus includes a second sensor configured to analyse the composition of the disinfecting and cleaning solution prepared in the receiving container.

[0016] In yet another embodiment, the receiving container is a flask or a disinfectant receiving container.

[0017] In one embodiment, the apparatus includes a control means connected to the means for supplying the electrolysed water.

[0018] In another embodiment, the control means is locally located.

[0019] In yet another embodiment, the control means is remotely located.

[0020] In an embodiment, the means for supplying electrolyzed water, fresh water, brine and additive(s) are pumps/valves.

[0021] In another embodiment, the means for supplying electrolyzed water, fresh water, brine and additive(s) uses external pressure to generate a flow.

[0022] In yet another embodiment, the means for supplying electrolyzed water, fresh water, brine and additive(s) employs gravity to generate a flow.

[0023] The present disclosure envisages an apparatus for manufacturing disinfecting and cleaning compositions. The apparatus comprises an electrolyzed water storage tank, a fresh water tank, and at least one additive carrying container. The electrolyzed water storage tank is configured to be in fluid communication with an electrolyzer. The electrolyzed water storage tank is configured to store electrolyzed water. The additive carrying container contains an additive(s). The apparatus optionally includes a brine tank for storing brine. Conduits connect the electrolyzed water storage tank, the fresh water tank, the additive carrying container(s) and the brine tank (if provided) to at least one receiving container for receiving therein electrolysed water, fresh water, brine (if any) and the additive(s). The apparatus further comprises means for supplying controlled amounts electrolysed water, controlled amounts of fresh water, controlled amounts of brine (if any), and controlled amounts of additive(s) into

the receiving container to obtain a disinfecting and cleaning solution. Further, the apparatus comprises a mixing chamber positioned upstream of the receiving container. The mixing chamber is configured to receive fresh water, electrolyzed water, brine and additive(s) therein from the fresh water tank, the electrolyzed water tank, the brine tank and the additive(s) carrying container(s). The mixing chamber is configured to enable homogenous mixing of the additive(s) with the fresh water, electrolyzed water and brine (if any).

[0024] In another embodiment, the mixing chamber includes an array of conduits having a plurality of pipes of varying cross-sections.

[0025] In another embodiment, the mixing chamber includes a pipe containing elements for generating turbulence therewithin. In yet another embodiment, the elements are balls. In still another embodiment, the balls are magnetizable. In still yet another embodiment, the mixing chamber includes a magnetizer for generating a variable magnetic field around the mixing chamber.

[0026] In one embodiment, the additive(s) are selected from the group consisting of surfactants, degreasers, fragrances, stabilizers, thickeners, colours, defoamers, viscosity enhancers, rheology modifiers, emulsifiers, dyes/colours, stain removers, scouring agents or a combination thereof.

[0027] In another embodiment, the apparatus is portable.

[0028] In yet another embodiment, the conduits are of inert polymeric composition selected from the group consisting of polypropylene, polyamide, polyethylene and polyvinyl chloride.

[0029] In an embodiment, the fresh water tank is a water reservoir containing fresh water.

[0030] In another embodiment, the fresh water tank is a tap water inlet.

[0031] The present disclosure further envisages a method for manufacturing disinfecting and cleaning compositions. The method comprises the following steps:

- receiving and storing electrolysed water in an electrolysed water storage tank;
- obtaining fresh water;
- receiving and storing at least one additive(s) in at least one additive carrying container(s);

- optionally receiving and storing brine in a brine tank; and
- supplying controlled amounts of electrolysed water, fresh water, additive(s) and optionally brine into a receiving container.

[0032] In another embodiment, the method includes the step of homogenously mixing the additive(s) with fresh water, electrolyzed water and brine (if any) in a mixing chamber positioned upstream of the receiving container.

[0033] In yet another embodiment, the method includes the step of sensing the parameters of the solution received in the receiving container to obtain a disinfecting and cleaning solution having predetermined parameters such as concentration of residual chlorine, NaOCl and HOCl, and a predetermined pH.

BRIEF DESCRIPTION OF THE DRAWINGS

[0034] An apparatus and a system for manufacturing disinfecting and cleaning compositions will now be described with the help of the accompanying drawing, in which:

Figure 1 illustrates a first embodiment of the system of the present disclosure;

Figure 2 illustrates a second embodiment of the system of the present disclosure;

Figure 3 illustrates a third embodiment of the system of the present disclosure;

Figure 4 illustrates a fourth embodiment of the system of the present disclosure;

Figure 5 illustrates a fifth embodiment of the system of the present disclosure;

Figure 6A illustrates the display board, of an input module of the system of Figure 1 and Figure 2, showing the type of composition desired to be produced for a particular surface; and

Figure 6B illustrates the display board, of the input module of Figure 6A, showing a quantity of composition to be produced;

LIST OF REFERENCE NUMERALS

200, 100 system

10 fresh water tank

12 pressure reducer

- 14, 14A mains valve
- 14B dispensing valve
- 16 electrolyzed water storage tank
- 17 float level switch
- 18 pump/valve
- 18A dispensing pump/valve
- 19 gas vent
- 20, 21, 22 additive carrying container
- 22A, 22B capacitive proximity sensor
- 23A, 23B auxiliary pump
- 24 controller
- 25 amplifier module
- 26 input module
- 27 load cell
- 28 stop plug
- 29 Y-connector
- 50 flask
- 55 receiving container
- 56 float switch
- 58 brine tank
- 59 array of conduits

60 mixing chamber

62 balls

64 strainer

65A, 65B magnet

S1 first sensors connected between pumps/valves 18 and an inlet of said receiving container

S2 second sensor provided in the receiving container 55

DETAILED DESCRIPTION OF THE INVENTION

[0035] Embodiments, of the present disclosure, will now be described with reference to the accompanying drawing.

[0036] Embodiments are provided so as to thoroughly and fully convey the scope of the present disclosure to the person skilled in the art. Numerous details are set forth, relating to specific components, and methods, to provide a complete understanding of embodiments of the present disclosure. It will be apparent to the person skilled in the art that the details provided in the embodiments should not be construed to limit the scope of the present disclosure. In some embodiments, well-known processes, well-known apparatus structures, and well-known techniques are not described in detail.

[0037] The terminology used, in the present disclosure, is only for the purpose of explaining a particular embodiment and such terminology shall not be considered to limit the scope of the present disclosure. As used in the present disclosure, the forms "a," "an," and "the" may be intended to include the plural forms as well, unless the context clearly suggests otherwise. The terms "comprises," "comprising," "including," and "having," are open ended transitional phrases and therefore specify the presence of stated features, elements, modules, units and/or components, but do not forbid the presence or addition of one or more other features, elements, components, and/or groups thereof.

[0038] When an element is referred to as being "mounted on," "engaged to," "connected to," or "coupled to" another element, it may be directly on, engaged, connected or coupled to the

other element. As used herein, the term "and/or" includes any and all combinations of one or more of the associated listed elements.

[0039] An apparatus and a system (100), of the present disclosure, for manufacturing disinfecting and cleaning compositions containing specific ingredients will now be described with reference to Figure 1 through Figure 6B.

[0040] In a first embodiment, the system (100) is configured to dispense small amounts of the disinfecting and cleaning composition into a container, typically a flask (50) (as shown in Figure 1).

[0041] In a second embodiment, the system (200) is configured to dispense large amounts of the disinfecting and cleaning compositions into a receiving container (55) (as shown in Figure 2).

[0042] The apparatus and system (100, 200) include an electrolyzed water storage tank (16), a fresh water tank (10), optionally a brine tank, and at least one additive carrying container (20, 21).

[0043] The electrolyzed water storage tank (16) is configured to receive electrolyzed chlorinated water and the other by-products of electrolysis, which includes hydrogen. Chlorinated water is the chief ingredient required to produce disinfecting and cleaning compositions envisaged in this disclosure. Hydrogen being light in nature remains at the upper portion of the storage tank (16). In an embodiment, the electrolyzed water storage tank (16) includes a gas vent (19) configured at an operative top portion of the storage tank (16). The gas vent (19) leads potentially hazardous gases away from the system (100, 200) to a location where it is safe to release these potentially hazardous gases.

[0044] The electrolyzed water storage tank (16) further includes a float level switch (17) which is configured to regulate the level of the chlorinated water in the tank (16), and dispense chlorinated water when it reaches a predetermined level.

[0045] A pump/valve (18) is connected to the electrolyzed water storage tank (16). The pump/valve (18) is configured to dispense a predetermined quantity of chlorinated water.

[0046] In an embodiment, for system (100), the electrolyzed water storage tank (16) is in fluid communication with the pump/valve (18) with the help of a piping system. The piping

system includes a Y-connector (29) (as shown in Figure 1). A first arm of the Y-connector (29) is connected to the pump/valve (18), while a second end of the Y-connector (29) is connected to a stop plug (28). When the stop plug (28) is attached to the second arm of the Y-connector (29), electrolyzed water is passed to the pump/valve (18) through the first arm of the Y-connector (29). On the other hand, if the stop plug (28) is removed, electrolyzed water is drained out through the second arm of the Y-connector (29). The Y-connector (29) thus facilitates selective flow of electrolyzed water.

[0047] The fresh water tank (10) is configured to store clean water therein. The fresh water tank (10) includes a pressure reducer (12) and at least one mains valve (14, 14A, 14B) connected thereto. The pressure reducer (12) is configured to maintain the pressure of water at a predetermined pressure range, typically lying in between 1-3 bar. The mains valves (14, 14A, 14B) is configured to regulate the flow rate of water from the fresh water tank (10).

[0048] In an embodiment, the fresh water tank (10) is a water reservoir. In another embodiment, the fresh water tank (10) is a tap water inlet.

[0049] In an embodiment, the brine tank (58) is configured to store brine.

[0050] The additive carrying container(s) (20, 21) is configured to contain therein an additive(s) typically selected from the group consisting of surfactants, degreasers, fragrances, stabilizers, thickeners, colors, defoamers, viscosity enhancers, rheology modifiers, emulsifiers, dyes/colours, stain removers, scouring agents or a combination thereof.

[0051] Furthermore, stabilizers (NaOH) can be added to optimize the viscosity, stability and increase the cleaning efficiency of electrolysed water for various applications such as toilet cleaning and floor cleaning.

[0052] Furthermore, colours can be added to the additive(s) to enhance user experience. The colours can be organic and bio-degradable, and are selected such that they do not affect the efficacy of electrolyzed water.

[0053] The apparatus includes conduits connecting electrolyzed water storage tank, the fresh water tank, the additive carrying container(s) and brine tank (if provided) to at least one receiving container for receiving therein electrolysed water, fresh water, brine (if any) and the additive(s).

[0054] The apparatus further includes means for supplying controlled amounts of electrolysed water, controlled amounts of fresh water, controlled amounts of brine (if any), and controlled amounts of additive(s) into the receiving container to obtain a disinfecting and cleaning solution.

[0055] In one embodiment of the invention, as shown in Figure 1, the additive carrying container(s) (20, 21) is connected to the flask (50). In another embodiment of the invention, as shown in Figure 2, the additive carrying container(s) (20, 21) is connected to the receiving container (55), typically with a barb fitting attached to the conduits, which enables a bayonet type connection for connecting two conduits to each other where one conduit is connected within the inner diameter of the other. Auxiliary pumps (23A, 23B) are fluidly connected to the additive carrying container(s) (20, 21). The auxiliary pumps (23A, 23B) are configured to dispense predetermined quantities of the additive(s) either to the flask (50) (Figure 1) or to the reservoir (55) (figure 2). In the figures of the present disclosure, only two additive(s) containers are shown. It is envisaged that more than two additive(s) containers may be there.

[0056] The system (100, 200) includes the apparatus, an input module (26), and a controller (24).

[0057] The input module (26) is configured to receive at least one input command from an operator. The input command corresponds to the type of disinfecting and/or cleaning composition which is to be produced, and its quantity.

[0058] The controller (24) is configured to be connected to the pump/valve (18) of the electrolyzed water storage tank (16), the pressure reducer (12) and the mains valves (14, 14A, 14B) of the fresh water tank (10), and the auxiliary pumps (23A, 23B) of the additive carrying container(s) (20, 21). The controller (24) includes a memory and a processor. The memory is configured to store a set of predetermined rules and threshold values. The processor is configured to cooperate with the memory to receive the set of pre-defined rules and values. The controller (24) is further connected to the input module (26), and is configured to receive the input command therefrom. The processor is further configured to generate processing signals based on the input command, and the stored rules and values. The pump/valve (18), the pressure reducer (12) and the mains valves (14, 14A, 14B), and the auxiliary pumps (23A, 23B) are configured to receive the processing signals, and are further

configured to dispense fresh water, electrolyzed water, and additive(s) based on the processing signals.

[0059] In an embodiment, the processor may be implemented as one or more microprocessors, microcomputers, digital signal processors, central processing units, state machines, logic circuitries, and/or any devices that manipulate signals based on operational instructions. Among other capabilities, the processor is configured to fetch and execute the predetermined set of rules stored in the memory either remotely or locally in a wired mode or wirelessly.

[0060] Further, the controller (24) can be remotely controlled with the help of internet or a cloud based remote monitoring system.

[0061] In another embodiment, the controller (24) includes a PCB mounted on the input module (26), and has an amplifier module (25).

[0062] In an embodiment, the apparatus includes a plurality of first sensors (S1) (as seen in Figure 3, but which can easily be understood with respect to the apparatus in Figures 1, 2, 4 and 5) connected between the means (18) for supplying electrolysed water, means (18) for supplying fresh water, means (18) for supplying brine (if any), and means (18) for supplying additive(s) and an inlet (not specifically marked in the drawing) of the receiving container (15). The first sensors (S1) are configured to obtain a feedback of electrolysed water, fresh water, the additive(s) and brine (if any) being supplied into the receiving container.

[0063] In another embodiment, the apparatus includes a second sensor (S2) configured to analyse the composition of the disinfecting and cleaning solution prepared in the receiving container (55).

[0064] In one embodiment, capacitive proximity sensors (22A, 22B) are connected to the additive carrying container(s) (20, 21). The sensors (22A, 22B) are configured to detect the amount of the additive(s) in the containers (20, 21), and are further configured to generate a signal when the amount of the additive(s) in the containers (20, 21) fall below a predetermined level. The controller (24) receives the signal, and discontinues supply of the additive(s) when the task is accomplished or when the additive(s) supply is exhausted.

[0065] In an embodiment, the flask (50) can be a container configured to contain relatively small amounts of the composition therein. In another embodiment, the flask (50) is a fogging bottle.

[0066] The system (100, 200) further includes means for supplying controlled amounts of electrolyzed water, fresh water and additive(s) into the receiving container to obtain a disinfecting and cleaning solution.

[0067] In an embodiment, the means for supplying the electrolysed water is a valve.

[0068] In another embodiment, the means for supplying controlled amounts of the electrolysed water uses external pressure to generate a flow.

[0069] In yet another embodiment, the means for supplying controlled amounts of the electrolysed water employs gravity to generate a flow.

[0070] In an embodiment, the float switch (56) is configured to generate a trigger signal once the level of the disinfecting and cleaning composition in the flask (50) of the system (100) or in the receiving container (55) of the system (200), reaches a predetermined level. The trigger signal is received by the controller (24) which then deactivates the pump, the pressure reducer and the mains valve, and the auxiliary pump (23A, 23B).

[0071] The system (100, 200) enables customization of the disinfecting and cleaning compositions having varying proportions of each ingredient as per the application. In an embodiment, the system (100, 200) can produce disinfecting and cleaning compositions having 0-100% concentration of electrolyzed water therein.

[0072] More specifically, the selection of type of additive(s) and quantity of additive(s), selection of quantity of fresh water, selection of quantity of electrolysed water, increase in the number of end use applications, and flexibility to produce chlorinated water with any concentration is enabled by the system (100, 200).

[0073] The system (100, 200) enables automatic dispensation of the disinfecting and cleaning composition of required amounts of the composition, and hence eliminates the need for continuous monitoring and controlling of the system (100, 200) by an operator otherwise required by conventional systems.

[0074] The system (100, 200) further includes a load cell (27) that allows measurement of the

flask (50) content for supplying the desired quantity of the disinfecting and cleaning composition in the flask (50).

[0075] In yet another embodiment, the conduits are of inert polymeric composition selected from the group consisting of polypropylene, polyamide, polyethylene and polyvinyl chloride.

[0076] The present disclosure further envisages a method for manufacturing disinfecting and cleaning compositions using electrolyzed chlorinated water. The method comprises the steps of:

- receiving and storing electrolyzed water in an electrolyzed water storage tank;
- obtaining fresh water;
- receiving and storing at least one additive(s) in an additive carrying container;
- supplying controlled amounts of electrolyzed water, fresh water and the additive(s) into a receiving container; and
- sensing the parameters of the solution received in the receiving container to obtain a disinfecting and cleaning solution having predetermined parameters such as concentration of residual chlorine, NaOCl and HOCl, and a predetermined pH.

[0077] Exemplary embodiments of the present disclosure will now be depicted as follows:

[0078] Electrolyzed water is collected in the electrolyzed water storage tank (16). Pre-mixed additive(s) are collected in the additive(s) flasks (20, 21, 22). The embodiment includes a brine tank (BT), as shown in Figure 3.

[0079] Fresh water from the fresh water tank (10) is introduced via the main valve (14A) and the dispensing valve (14B) to the receiving container (55)/flask (50).

[0080] The apparatus dispenses different types of compositions as pre-formulated in the system. These compositions have a plurality of inputs, namely electrolyzed water, the fresh water, the additive(s) and brine (if any) as discussed herein. They are added in proportions controlled by the valves and the pumps.

[0081] In a particular embodiment, some of the additive(s) can be in a viscous state, whereas others may be semi-viscous or liquid. The additive(s) can be homogeneously mixed with electrolyzed water, fresh water and brine (if any) to make final usable composition. The final

composition typically may or may not need any dilution for cleaning and disinfection before use.

[0082] There are several other embodiments of the apparatus which may include the use of step of homogenous mixing before the ingredients are supplied to the receiving container.

As shown in Figure 3 through Figure 5, the present disclosure further envisages an apparatus for manufacturing disinfecting and cleaning compositions. The apparatus comprises an electrolyzed water storage tank configured to be in fluid communication with an electrolyzer. The electrolyzed water storage tank is configured to store electrolyzed water. The apparatus further comprises a fresh water tank, at least one additive carrying container containing an additive(s), a brine tank for supplying controlled quantities of brine to the receiving container, conduits connecting the electrolyzed water storage tank, the fresh water tank, and the additive carrying container(s) to at least one receiving container, means for supplying controlled amounts of the electrolysed water, fresh water, brine and the additive(s) into the receiving container to obtain a disinfecting and cleaning solution. The present disclosure additionally comprises a mixing chamber positioned upstream of the receiving container. The mixing chamber is configured to receive fresh water, electrolyzed water, brine and additive(s) therein from the fresh water tank, the electrolyzed water tank, the brine tank and the additive carrying container(s). The mixing chamber is configured to enable homogenous mixing of the additive(s) with fresh water, electrolyzed water and brine.

[0083] For instance, in accordance with a third embodiment, shown in Figure 3, fresh water, additive(s), electrolyzed water and brine can be added together before final supplying in the receiving container (55). The fresh water can be supplied to a mixing chamber (60), in the form of an array of conduits (59) comprising pipes of varying cross-sections. The conduits can include pipes of around 100 mm in length, and have an inside diameter ranging between 200mm and 500mm connected to each other by expanders and reducers. Additive(s) 1, 2 and 3 can be added to the mixing chamber (60). Typically, additive(s) 1 and 2 can be highly viscous fluids, and additive(s) can be semi-viscous or liquid.

[0084] Thereafter, electrolyzed water, fresh water, and brine (if any) can be added to the mixing chamber (60). The flow of fresh water, electrolyzed water, brine (if any) and additive(s) to the array of conduits (59) can be controlled by means of pumps/valves (18).

[0085] In one embodiment, the pumps/valves (18) can be peristaltic pumps or a combination of the two.

[0086] Since the pipes of the array of conduits (59) are of varying cross-sections, the change in the volumes of the pipes creates change in velocities of the flow of the composition. This creates turbulence in the composition which will mix the additive(s) with fresh water and electrolyzed water. The peristaltic pump which starts and stops will create more turbulence.

[0087] The homogeneously mixed formulation is thereafter dispensed from the mixing chamber (60) with the help of a dispensing pump/valve (18A), which facilitates controlled flow of the formulation from the mixing chamber (60) into the receiving container (55).

[0088] The array of conduits (59) can be manufactured from polymeric material, typically selected from a group consisting of polyethylene or polyvinyl chloride.

[0089] The pump/valve (18A) can be connected to the array of conduits (59) for supplying a final homogeneous, diluted and pre-programmed quantity of the composition therethrough.

[0090] A typical sequence of operation can be as follows:

- the pumps/valves (18) of the additive(s) can be started;
- after 5 seconds, the fresh water will be supplied by operating a pump/valve (18);
- during this time, the pump/valve (18A) for supplying the composition will be switched off, and started after 20 seconds to create increase in volume and turbulence in the composition; and
- after 25 seconds, both the electrolyzed water pump/valve (18) and the brine pump/valve (18) can be made operational to add the disinfectant and brine to the final composition.

[0091] The operation enables homogeneous mixing of the additive(s) with fresh water and electrolyzed water due to turbulence.

[0092] In accordance with a fourth embodiment, as shown in Figure 4, a pipe can be used as a mixing chamber (60) to create high speed flow. In this embodiment, the pipe can contain elements such as plastic balls (62) for generating relatively greater turbulence. The balls (62) can be held in place with a coarse strainer (64) or different shaped objects at the end of the pipe (60) so that the balls (62) do not block the flow of the fluid from the pipe (60).

[0093] In accordance with a fifth embodiment, as shown in Figure 5, magnets (65A, 65B) are located around a mixing chamber (60) which is relatively smaller in size, and the chamber (60) is vigorously rotated to cause homogenization. Alternatively, the mixing chamber (60) may contain heavy magnetizable balls (62), that due to vibrations caused by an external (vibration) magnetizer are displaced to homogenize the composition.

[0094] The foregoing description of the embodiments has been provided for purposes of illustration and not intended to limit the scope of the present disclosure. Individual components of a particular embodiment are generally not limited to that particular embodiment, but, are interchangeable. Such variations are not to be regarded as a departure from the present disclosure, and all such modifications are considered to be within the scope of the present disclosure.

TECHNICAL ADVANCEMENTS

[0095] The present disclosure described herein above has several technical advantages including, but not limited to, the realization of an apparatus, a system and a method for manufacturing disinfecting and cleaning compositions, which;

- can manufacture a variety of disinfecting and cleaning compositions having different constituents and ingredients within the same system and apparatus;
- can be customized to produce different concentrations and quantities disinfecting and cleaning compositions;
- can automatically dispense the disinfecting and cleaning compositions; and
- can be remotely controlled.

[0096] The embodiments herein and the various features and advantageous details thereof are explained with reference to the non-limiting embodiments in the following description. Descriptions of well-known components and processing techniques are omitted so as to not unnecessarily obscure the embodiments herein. The examples used herein are intended merely to facilitate an understanding of ways in which the embodiments herein may be practiced and to further enable those of skill in the art to practice the embodiments herein. Accordingly, the examples should not be construed as limiting the scope of the embodiments herein.

[0097] The foregoing description of the specific embodiments so fully reveal the general nature of the embodiments herein that others can, by applying current knowledge, readily modify and/or adapt for various applications such specific embodiments without departing from the generic concept, and, therefore, such adaptations and modifications should and are intended to be comprehended within the meaning and range of equivalents of the disclosed embodiments. It is to be understood that the phraseology or terminology employed herein is for the purpose of description and not of limitation. Therefore, while the embodiments herein have been described in terms of preferred embodiments, those skilled in the art will recognize that the embodiments herein can be practiced with modification within the spirit and scope of the embodiments as described herein.

[0098] The use of the expression “at least” or “at least one” suggests the use of one or more elements or ingredients or quantities, as the use may be in the embodiment of the disclosure to achieve one or more of the desired objects or results.

[0099] Any discussion of materials, devices, articles or the like that has been included in this specification is solely for the purpose of providing a context for the disclosure. It is not to be taken as an admission that any or all of these matters form a part of the prior art base or were common general knowledge in the field relevant to the disclosure as it existed anywhere before the priority date of this application.

[0100] While considerable emphasis has been placed herein on the components and component parts of the preferred embodiments, it will be appreciated that many embodiments can be made and that many changes can be made in the preferred embodiments without departing from the principles of the disclosure. These and other changes in the preferred embodiment as well as other embodiments of the disclosure will be apparent to those skilled in the art from the disclosure herein, whereby it is to be distinctly understood that the foregoing descriptive matter is to be interpreted merely as illustrative of the disclosure and not as a limitation

CLAIMS:

1. An apparatus for manufacturing disinfecting and cleaning compositions, said apparatus comprising:
 - an electrolyzed water storage tank configured to be in fluid communication with an electrolyzer, said electrolyzed water storage tank configured to store electrolyzed water;
 - a fresh water tank;
 - at least one additive carrying container containing an additive(s);
 - optionally a brine tank configured to store brine;
 - conduits connecting the electrolyzed water storage tank, the fresh water tank, said additive carrying container(s) and brine tank (if provided) to at least one receiving container for receiving therein electrolysed water, fresh water, brine (if any) and the additive(s); and
 - means for supplying:
 - controlled amounts of electrolysed water,
 - controlled amounts of fresh water,
 - controlled amounts of brine (if any), and
 - controlled amounts of additive(s)into said receiving container to obtain a disinfecting and cleaning solution.
2. The apparatus as claimed in claim 1, wherein a gas vent is provided on said electrolysed water storage tank to vent out potentially hazardous gases that may collect in the storage tank.
3. The apparatus as claimed in claim 1, which includes a plurality of first sensors (S1) connected between said means for supplying electrolysed water and an inlet of said receiving container, said first sensors (S1) configured to obtain a feedback of electrolysed water, fresh water, additive(s) and brine being supplied to said receiving container.

4. The apparatus as claimed in claim 1, which includes a second sensor (S2) configured to analyse the composition of the disinfecting and cleaning solution prepared in the receiving container.
5. The apparatus as claimed in claim 1, wherein said receiving container is a flask or a disinfectant storage reservoir.
6. The apparatus as claimed in claim 1, which includes a control means connected to said means for supplying electrolysed water.
7. The apparatus as claimed in claim 6, wherein said control means is locally located.
8. The apparatus as claimed in claim 6, wherein said control means is remotely located.
9. The apparatus as claimed in claim 1, wherein said means for supplying electrolyzed water, fresh water, brine and additive(s) are pumps/valves.
10. The apparatus as claimed in claim 9, wherein said means for supplying electrolyzed water, fresh water, brine and additive(s) use external pressure to generate a flow.
11. The apparatus as claimed in claim 9, wherein said means for supplying electrolyzed water, fresh water, brine and additive(s) employ gravity to generate a flow.
12. An apparatus for manufacturing disinfecting and cleaning compositions, said apparatus comprising:
 - an electrolyzed water storage tank configured to be in fluid communication with an electrolyzer, said electrolyzed water storage tank configured to store electrolyzed water;
 - a fresh water tank;
 - at least one additive carrying container containing an additive(s);
 - a brine tank configured to store brine;
 - conduits connecting the electrolyzed water storage tank, the fresh water tank, said additive carrying container(s) and brine tank (if provided) to at least one receiving container for receiving therein electrolysed water, fresh water, brine (if any) and the additive(s);
 - means for supplying:

- controlled amounts of electrolysed water,
- controlled amounts of fresh water,
- controlled amounts of brine (if any), and
- controlled amounts of additive(s)

into said receiving container to obtain a disinfecting and cleaning solution; and

- a mixing chamber positioned upstream of said receiving container, said mixing chamber configured to receive fresh water, electrolyzed water, brine and additive(s) therein from said fresh water tank, said electrolyzed water tank, said brine tank and said additive carrying container, said mixing chamber configured to enable homogenous mixing of additive(s) with the fresh water, the electrolyzed water and brine.
13. The apparatus as claimed in claim 12, wherein said mixing chamber includes an array of conduits having a plurality of pipes of varying cross-sections.
 14. The apparatus as claimed in claim 12, wherein said mixing chamber includes a pipe containing elements for generating turbulence therewithin.
 15. The apparatus as claimed in claim 14, wherein said elements are balls.
 16. The apparatus as claimed in claim 15, wherein said balls are magnetizable.
 17. The apparatus as claimed in claim 16, wherein said mixing chamber includes a magnetizer for generating a variable magnetic field around said mixing chamber.
 18. The apparatus as claimed in claim 1, wherein additive(s) are selected from the group consisting of surfactants, degreasers, fragrances, stabilizers, thickeners, colours, defoamers, viscosity enhancers, rheology modifiers, emulsifiers, dyes/colours, stain removers, scouring agents or a combination thereof.
 19. The apparatus as claimed in claim 1, wherein said apparatus is portable.
 20. The apparatus as claimed in claim 1, wherein said conduits are of inert polymeric composition selected from the group consisting of polypropylene, polyamide, polyethylene and polyvinyl chloride.

21. The apparatus as claimed in claim 1, wherein the fresh water tank is a water reservoir containing fresh water.
22. The apparatus as claimed in claim 1, wherein the fresh water tank is a tap water inlet.
23. A method for manufacturing disinfecting and cleaning compositions, said method comprising the steps of:
 - receiving and storing electrolysed water in an electrolysed water storage tank;
 - obtaining fresh water;
 - receiving and storing at least one additive(s) in at least one additive carrying container(s);
 - optionally receiving and storing brine in a brine tank; and
 - dispensing controlled amounts of electrolysed water, fresh water, additive(s) and optionally brine into a receiving container.
24. The method as claimed in claim 23, which includes the step of homogenously mixing additive(s) with fresh water, electrolyzed water and brine (if any) in a mixing chamber positioned upstream of said receiving container.
25. The method as claimed in claim 23, which includes the step of sensing the parameters of the solution received in the receiving container to obtain a disinfecting and cleaning solution having predetermined parameters such as concentration of residual chlorine, NaOCl and HOCl, and a predetermined pH.

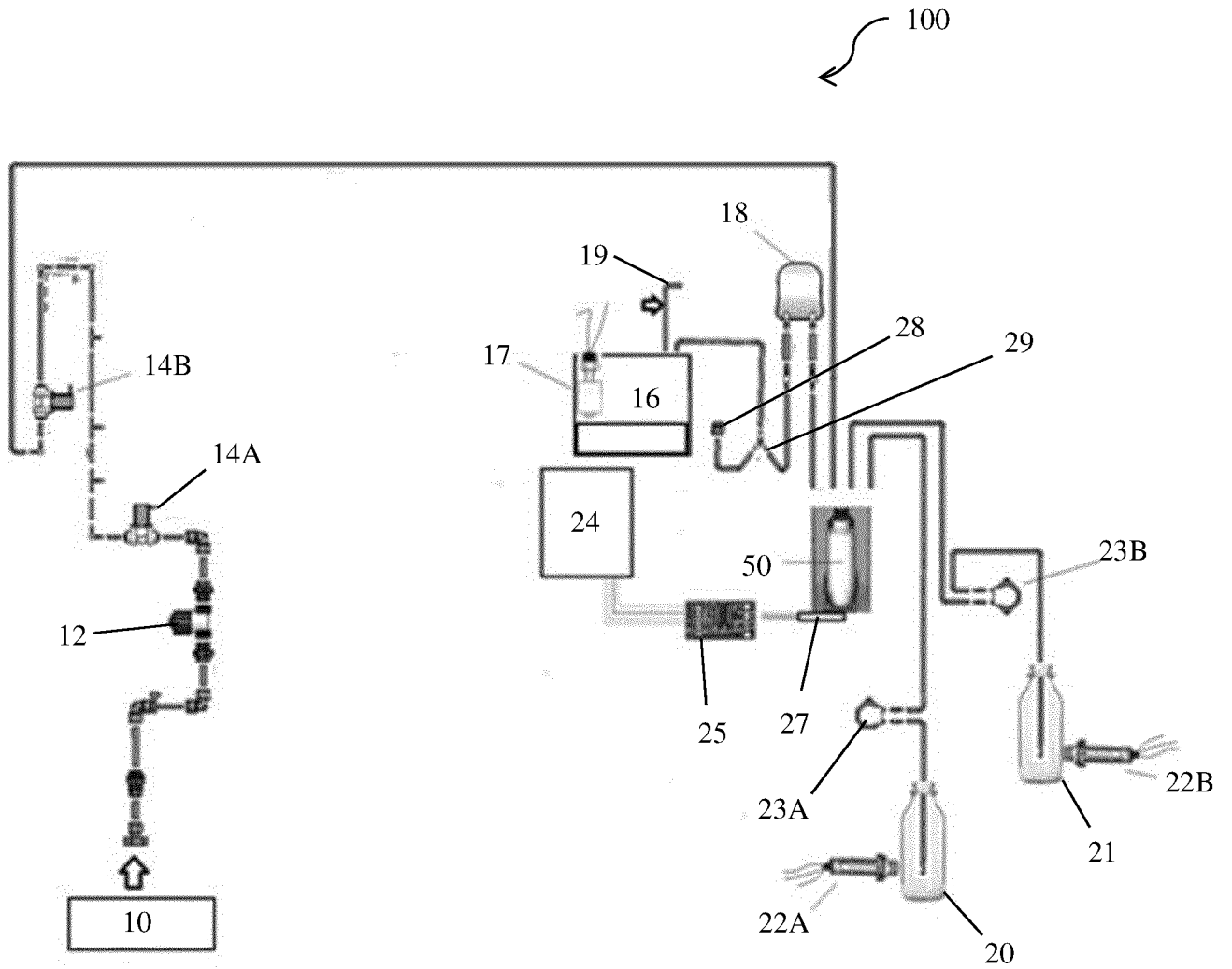

Figure 1

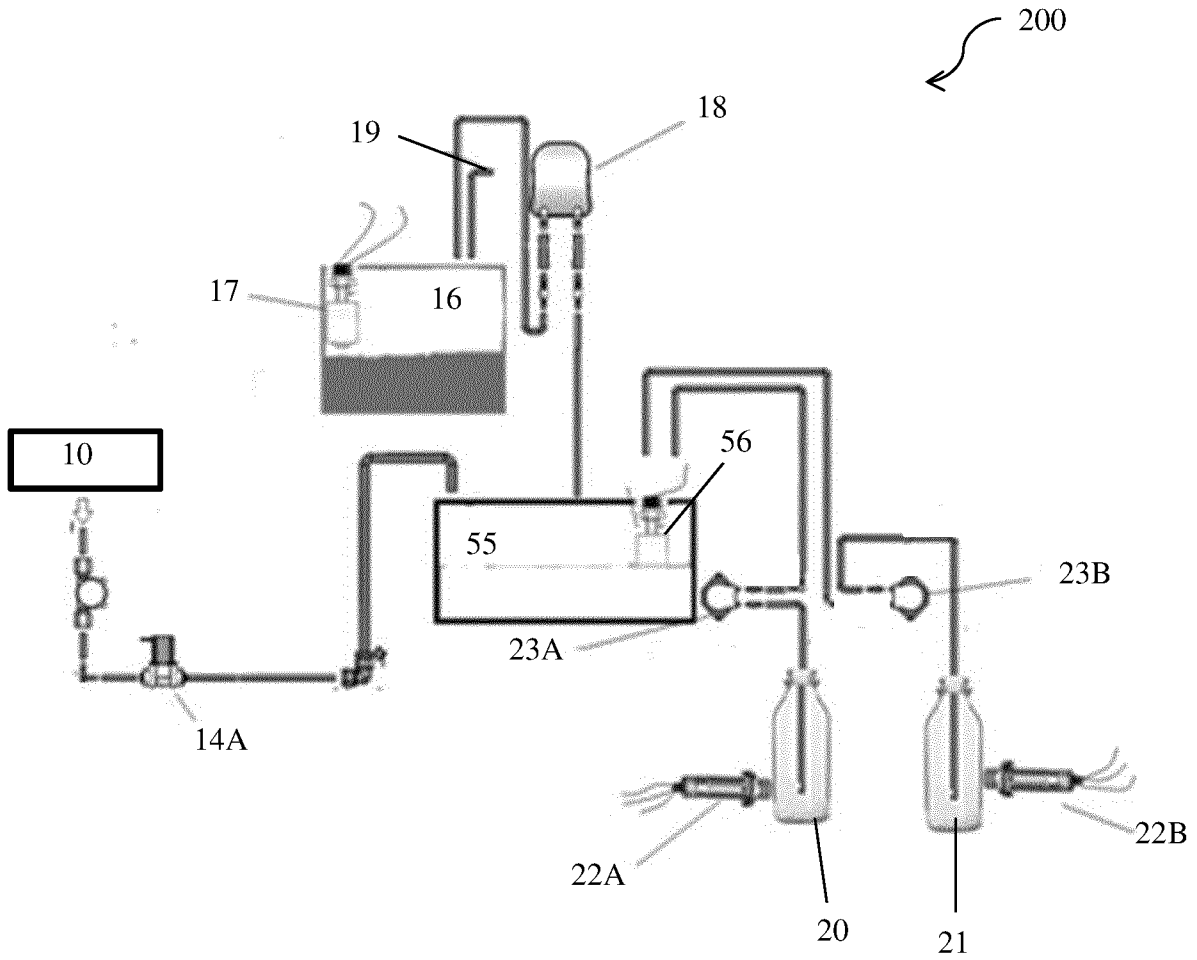

Figure 2

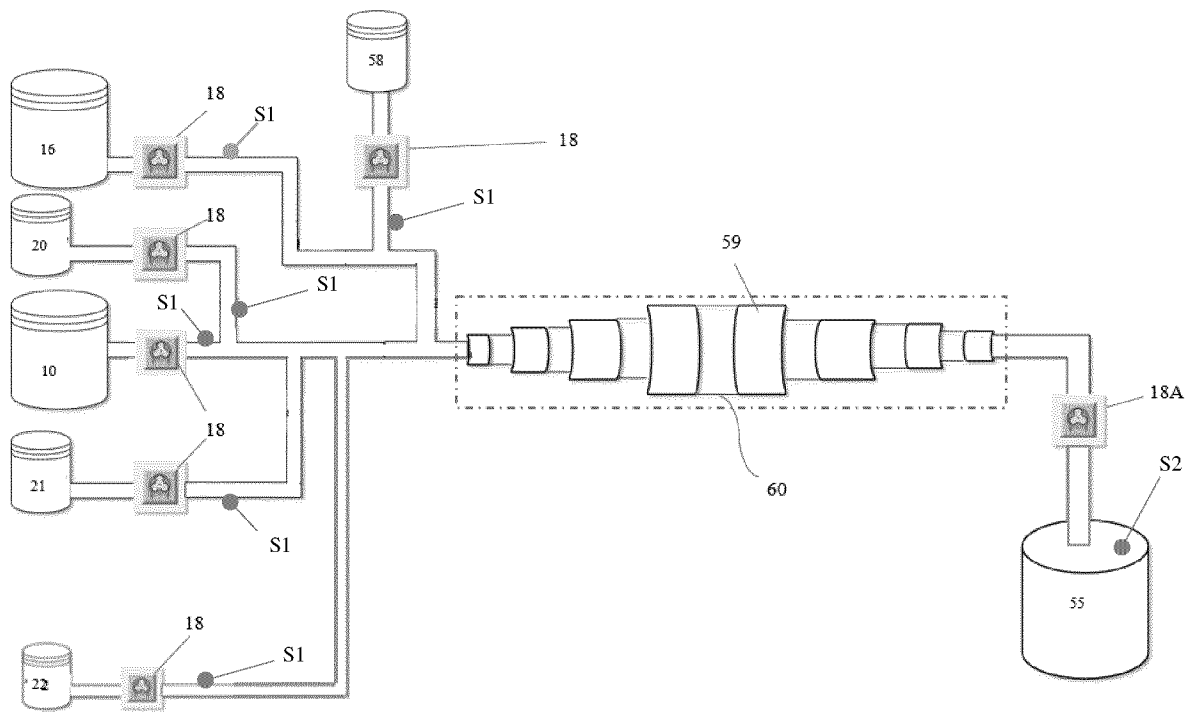

Figure 3

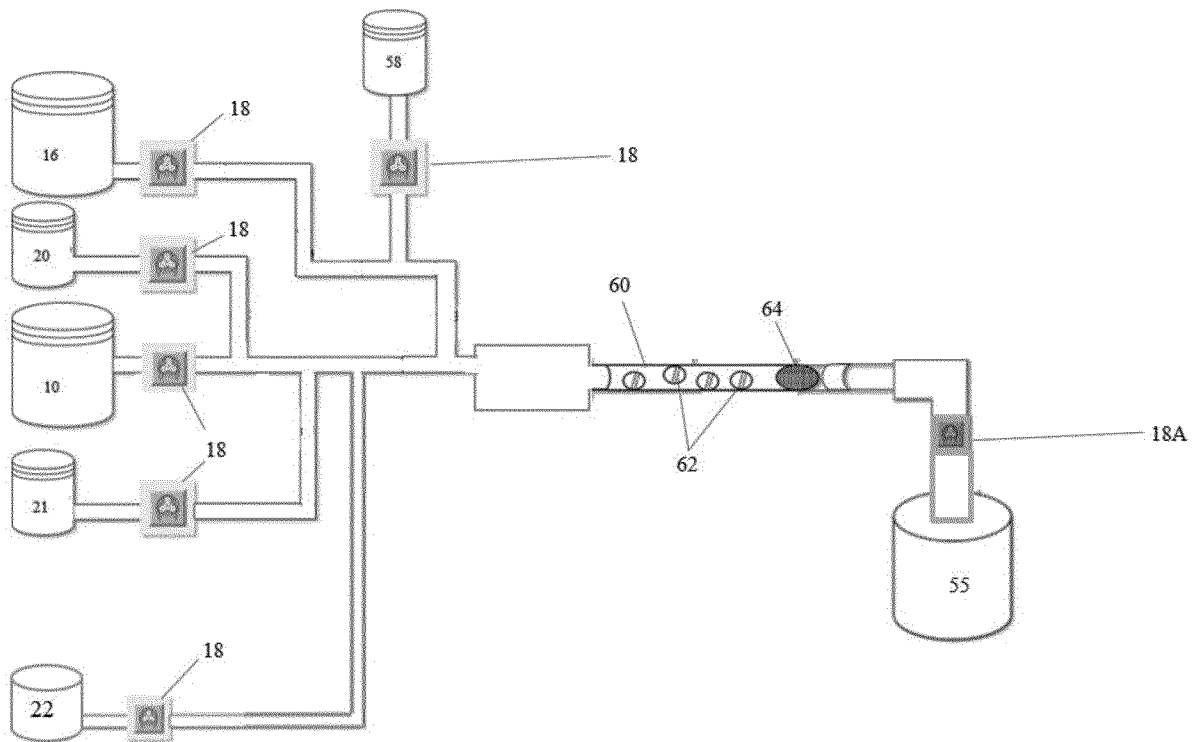

Figure 4

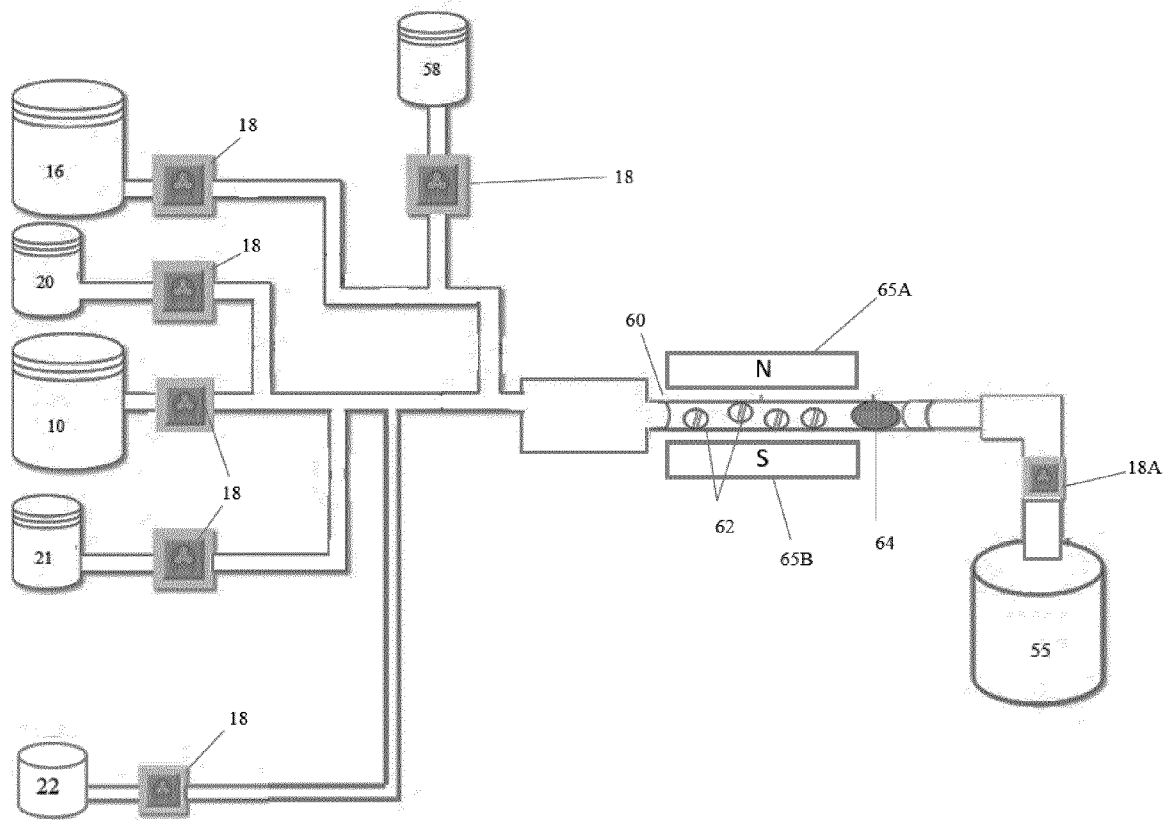

Figure 5

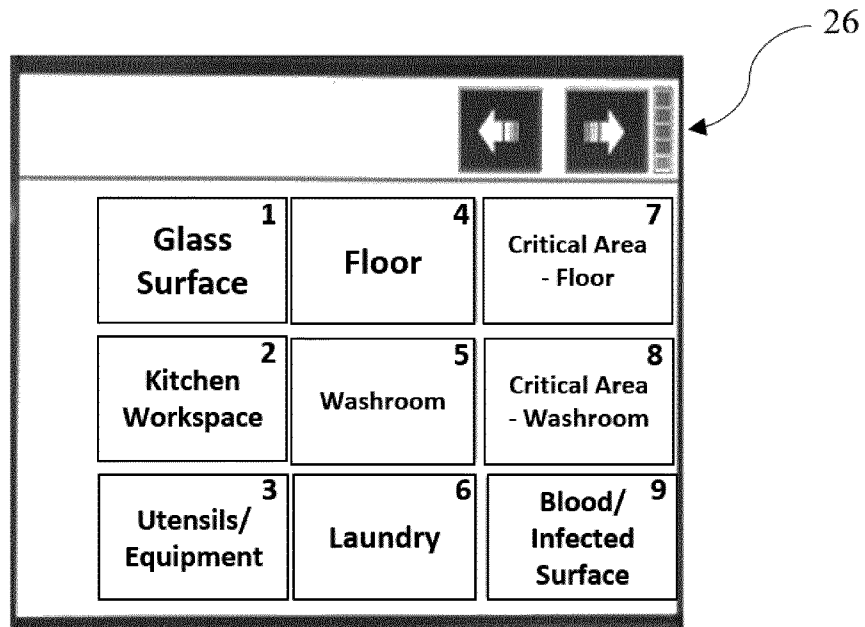

Figure 6A

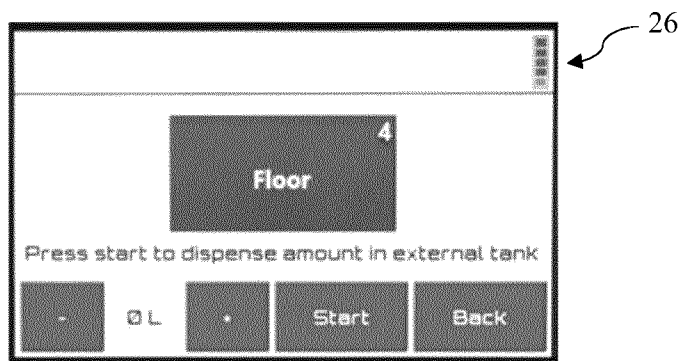

Figure 6B

INTERNATIONAL SEARCH REPORT

International application No
PCT/EP2022/063639

A. CLASSIFICATION OF SUBJECT MATTER
INV. C02F1/467 B01F23/43 B01F33/25 B01F33/45 C02F1/68
B01F23/70
ADD. C02F103/02
 According to International Patent Classification (IPC) or to both national classification and IPC

B. FIELDS SEARCHED
 Minimum documentation searched (classification system followed by classification symbols)
C02F B01F

Documentation searched other than minimum documentation to the extent that such documents are included in the fields searched

Electronic data base consulted during the international search (name of data base and, where practicable, search terms used)
EPO-Internal, WPI Data

C. DOCUMENTS CONSIDERED TO BE RELEVANT

Category*	Citation of document, with indication, where appropriate, of the relevant passages	Relevant to claim No.
X	US 2001/010296 A1 (HIROTA TATSUYA [JP] ET AL) 2 August 2001 (2001-08-02) paragraphs [0088], [0107] - [0115]; figures 7-9 -----	1-6, 9-17, 20, 22, 23
X	US 2012/000488 A1 (HERDT BRANDON [US] ET AL) 5 January 2012 (2012-01-05) paragraphs [0041], [0046] - [0049], [0057]; figure 4 -----	1, 3-18, 21, 23-25
X	WO 2019/126809 A1 (HCI CLEANING PRODUCTS LLC [US]) 27 June 2019 (2019-06-27) paragraphs [0051], [0056]; figures 1, 2 -----	1, 2, 5, 19, 23
A	US 2016/121281 A1 (GEIGES THOMAS [CH]) 5 May 2016 (2016-05-05) paragraphs [0045] - [0047] -----	14-17

Further documents are listed in the continuation of Box C.

See patent family annex.

* Special categories of cited documents :

- "A" document defining the general state of the art which is not considered to be of particular relevance
- "E" earlier application or patent but published on or after the international filing date
- "L" document which may throw doubts on priority claim(s) or which is cited to establish the publication date of another citation or other special reason (as specified)
- "O" document referring to an oral disclosure, use, exhibition or other means
- "P" document published prior to the international filing date but later than the priority date claimed

- "T" later document published after the international filing date or priority date and not in conflict with the application but cited to understand the principle or theory underlying the invention
- "X" document of particular relevance; the claimed invention cannot be considered novel or cannot be considered to involve an inventive step when the document is taken alone
- "Y" document of particular relevance; the claimed invention cannot be considered to involve an inventive step when the document is combined with one or more other such documents, such combination being obvious to a person skilled in the art
- "&" document member of the same patent family

Date of the actual completion of the international search

23 August 2022

Date of mailing of the international search report

31/08/2022

Name and mailing address of the ISA/
 European Patent Office, P.B. 5818 Patentlaan 2
 NL - 2280 HV Rijswijk
 Tel. (+31-70) 340-2040,
 Fax: (+31-70) 340-3016

Authorized officer

Wolf, Gundula

INTERNATIONAL SEARCH REPORT

Information on patent family members

International application No

PCT/EP2022/063639

Patent document cited in search report	Publication date	Patent family member(s)	Publication date
US 2001010296 A1	02-08-2001	CN 1304883 A	25-07-2001
		EP 1108684 A2	20-06-2001
		KR 20010062503 A	07-07-2001
		US 2001010296 A1	02-08-2001

US 2012000488 A1	05-01-2012	AU 2011272996 A1	13-12-2012
		CA 2799756 A1	05-01-2012
		CN 102958391 A	06-03-2013
		CN 104491891 A	08-04-2015
		CN 113088991 A	09-07-2021
		EP 2587945 A2	08-05-2013
		EP 2623126 A2	07-08-2013
		EP 2623465 A2	07-08-2013
		ES 2676548 T3	20-07-2018
		ES 2676559 T3	20-07-2018
		JP 5856160 B2	09-02-2016
		JP 6577353 B2	18-09-2019
		JP 2013538107 A	10-10-2013
		JP 2016101583 A	02-06-2016
		JP 2019069443 A	09-05-2019
		US 2012000488 A1	05-01-2012
		WO 2012001618 A2	05-01-2012

WO 2019126809 A1	27-06-2019	NONE	

US 2016121281 A1	05-05-2016	EP 3003544 A1	13-04-2016
		US 2016121281 A1	05-05-2016
		WO 2014194947 A1	11-12-2014
